

1. [Static pressure & monometer]

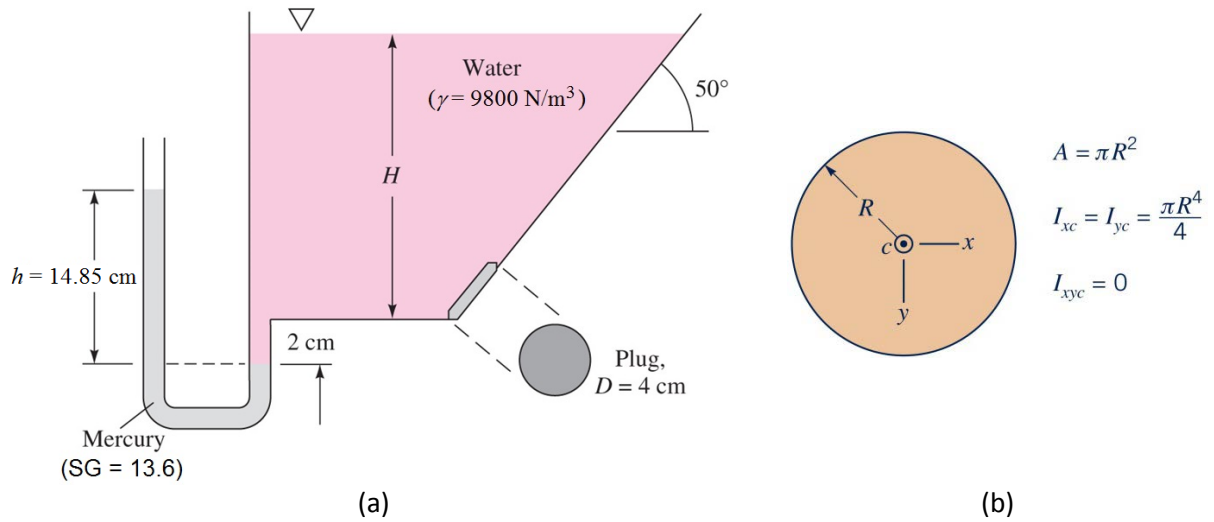

(a) Monometer (+2 points)

$$p_{atm} + \gamma \cdot SG \cdot h - \gamma(H + 0.02) = p_{atm}$$

$$\therefore H = SG \cdot h - 0.02 = (13.6)(0.1485) - 0.02 = \mathbf{2.0 \text{ m}}$$

(b1) Hydrostatic pressure force (+4 points)

$$h_c = H - \left(\frac{D}{2}\right) \sin 50^\circ = 2 - \left(\frac{0.04}{2}\right) \sin 50^\circ = 1.985 \text{ m}$$

$$A = \frac{\pi D^2}{4} = \frac{\pi \times 0.04^2}{4} = 1.257 \times 10^{-3} \text{ m}^2$$

$$F_R = \gamma h_c A = (9800)(1.987)(1.257 \times 10^{-3}) = \mathbf{24.5 \text{ N}}$$

(b2) Pressure center (+4 points)

$$\bar{y} = \frac{h_c}{\sin 50^\circ} = \frac{1.985}{\sin 50^\circ} = 2.591 \text{ m}$$

$$I_x = \frac{\pi R^4}{4} = \frac{(\pi)(0.04/2)^4}{4} = 1.257 \times 10^{-7} \text{ m}^4$$

$$\therefore y_R = \bar{y} + \frac{I_x}{\bar{y}A} = 2.591 + \frac{1.257 \times 10^{-7}}{(2.591)(1.257 \times 10^{-3})} = \mathbf{2.591 \text{ m}}$$

2. [Continuity+Momentum+Energy]

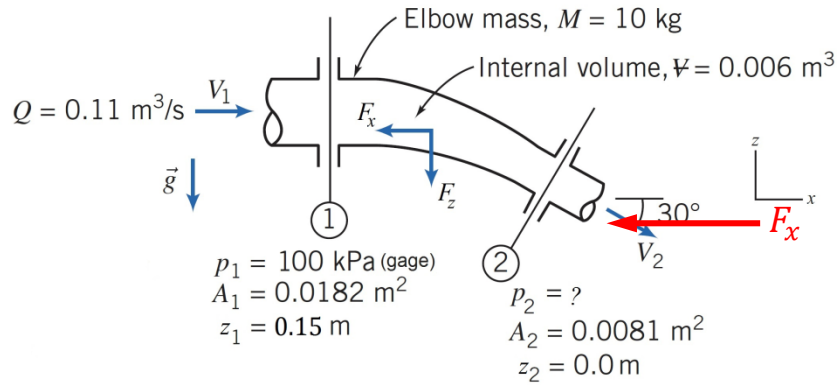

(a) Continuity (+1 point)

$$V_1 = \frac{Q}{A_1} = \frac{0.11}{0.0182} = \mathbf{6.0 \text{ m/s}}$$

$$V_2 = \frac{Q}{A_2} = \frac{0.11}{0.0081} = \mathbf{13.6 \text{ m/s}}$$

(b) Energy equation (+3 points)

$$p_2 = p_1 + \gamma \left[\frac{V_1^2 - V_2^2}{2g} + (z_1 - z_2) \right]$$

$$\therefore p_2 = 100,000 + (9800) \left[\frac{6^2 - 13.6^2}{2 \times 9.81} + 0.15 \right] = \mathbf{27,066 \text{ Pa}}$$

(c1) x-momentum (+3 points)

$$-F_x + p_1 A_1 - p_2 A_2 \cos \theta = (\rho Q) V_2 \cos \theta - (\rho Q) V_1$$

or

$$F_x = +p_1 A_1 - p_2 A_2 \cos 30^\circ - (\rho Q)(V_2 \cos 30^\circ - V_1)$$

$$\therefore F_x = (100,000)(0.0182) - (27,066)(0.0081) \cos 30^\circ - (999)(0.11)(13.6 \cos 30^\circ - 6) = \mathbf{995 \text{ N}}$$

(c2) y-momentum (+3 points)

$$-F_z + p_2 A_2 \sin \theta - Mg - \gamma \Psi = (\rho Q)(-V_2 \sin \theta) - (\rho Q)(0)$$

or

$$F_z = p_2 A_2 \sin \theta - Mg - \gamma \Psi + \rho Q V_2 \sin \theta$$

$$\therefore F_z = (27,066)(0.0081) \sin 30^\circ - (10)(9.81) - (9800)(0.006) + (999)(0.11)(13.6) \sin 30^\circ = \mathbf{700 \text{ N}}$$

3. [Navier-Stokes]

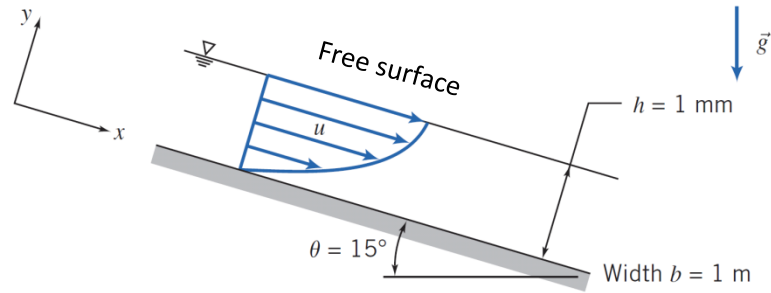

(a) B.C. at $x = h$ (+4 points)

$$\tau(h) = \mu \left. \frac{du}{dy} \right|_{y=h} = \mu \cdot \frac{\rho g \sin \theta}{\mu} (C - h) = 0$$

$$\therefore C = h$$

(b) Acceleration (+2 points)

$$\therefore \frac{\partial u}{\partial t} = \frac{\partial v}{\partial t} = \frac{\partial w}{\partial t} = \frac{\partial u}{\partial x} = \frac{\partial u}{\partial z} = v = w = 0,$$

$$a_x = \frac{\partial u}{\partial t} + u \frac{\partial u}{\partial x} + v \frac{\partial u}{\partial y} + w \frac{\partial u}{\partial z} = 0 + (u)(0) + (0) \left(\frac{\partial u}{\partial y} \right) + (0)(0) = 0$$

$$a_y = \frac{\partial v}{\partial t} + u \frac{\partial v}{\partial x} + v \frac{\partial v}{\partial y} + w \frac{\partial v}{\partial z} = 0 + (u)(0) + (0)(0) + (0)(0) = 0$$

$$a_z = \frac{\partial w}{\partial t} + u \frac{\partial w}{\partial x} + v \frac{\partial w}{\partial y} + w \frac{\partial w}{\partial z} = 0 + (u)(0) + (0)(0) + (0)(0) = 0$$

(c) Flow rate (+4 points)

$$Q = \int_0^h \frac{\rho g \sin \theta}{\mu} \left(hy - \frac{y^2}{2} \right) b dy = \frac{\rho g \sin \theta b}{\mu} \left[\frac{hy^2}{2} - \frac{y^3}{6} \right]_0^h$$

$$\therefore Q = \frac{\rho g \sin \theta b h^3}{3\mu} = \frac{(912)(9.81)(\sin 15^\circ)(1)(0.001)^3}{(3)(0.38)} = 2.03 \times 10^{-6} \text{ m}^3/\text{s}$$

4. [Major+Minor - Q]

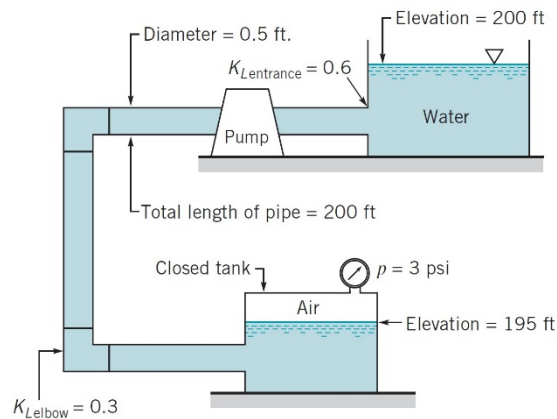

Energy equation (+5 points)

Energy equation with $p_1 = 0$ and $V_1 = V_2 = 0$,

$$0 + 0 + z_1 + h_p = \frac{p_2}{\gamma} + 0 + z_2 + f \frac{L}{D} \frac{V^2}{2g} + \sum K_L \frac{V^2}{2g}$$

or

$$200 + 15 = \frac{3 \times 144}{62.4} + 195 + f \frac{200}{0.5} \frac{V^2}{2 \times 32.2} + (0.6 + 2 \times 0.3) \frac{V^2}{2 \times 32.2}$$

Solve for V ,

$$V = \sqrt{\frac{842.2}{400f + 1.2}} \left(\text{or } \sqrt{\frac{13.0769}{6.2112f + 0.0186}} \right) \quad (1)$$

Iteration process (+4 points)

$$Re = \frac{\rho V D}{\mu} = \frac{(1.94)(V)(0.5)}{2.34 \times 10^{-5}} = 41,453 \cdot V \quad (2)$$

$$\frac{1}{\sqrt{f}} = -1.8 \log \left[\left(\frac{\epsilon/D}{3.7} \right)^{1.1} + \frac{6.9}{Re} \right] = -1.8 \log \left[\left(\frac{0.003/0.5}{3.7} \right)^{1.1} + \frac{6.9}{Re} \right] \quad (3)$$

Assume $f = 0.03$ and using (1), (2), and (3) in sequence,

$$V = 7.988 \rightarrow Re = 3.31 \times 10^5 \rightarrow f = 0.033$$

Assume $f = 0.033$,

$$V = 7.648 \rightarrow Re = 3.17 \times 10^5 \rightarrow f = 0.033 \text{ (Converged)}$$

1)

Flow rate (+1 point)

$$A = \frac{\pi D^2}{4} = \frac{\pi \times 0.5^2}{4} = 0.196 \text{ m}^2$$

$$Q = VA = (7.648)(0.196) = 1.5 \text{ ft}^3/\text{s}$$

5. [Boundary layer]

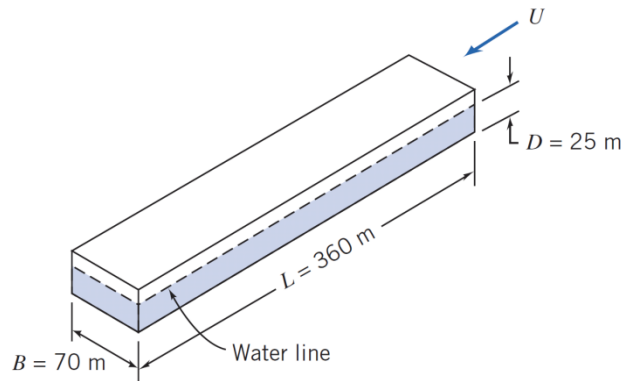

a1) Reynolds number (+2 points)

$$U = 5 \times 0.5144 = 2.572 \text{ m/s}$$
$$Re_L = \frac{\rho UL}{\mu} = \frac{(1030)(2.572)(360)}{1.20 \times 10^{-3}} = 7.95 \times 10^8$$

a2) Friction drag coefficient (+3 points)

$$C_f = \frac{0.455}{(\log_{10} Re_L)^{2.58}} = \frac{0.455}{(\log_{10} 7.95 \times 10^8)^{2.58}} = 0.00162$$

or

$$C_f = \frac{0.031}{Re_L^{\frac{1}{7}}} = \frac{0.031}{(7.95 \times 10^8)^{\frac{1}{7}}} = 0.00166$$

b1) Friction Drag (+3 points)

$$A = Lb = (360)(70 + 2 \times 25) = 43,200 \text{ m}^2$$

$$F_D = \frac{1}{2} \rho U^2 A \cdot C_f = \frac{1}{2} (1030)(2.572)^2 (43200)(0.00162) = \mathbf{2.38 \times 10^5 \text{ N}}$$

Or

$$F_D = \mathbf{2.44 \times 10^5 \text{ N}}$$

b2) Power (+2 points)

$$P = F_D U = (2.38 \times 10^5)(2.572) = \mathbf{6.12 \times 10^5 \text{ W}} \approx 0.6 \text{ MW}$$

or

$$P = \mathbf{6.28 \times 10^5 \text{ W}}$$

6. [Pi theorem + Drag+Similarity]

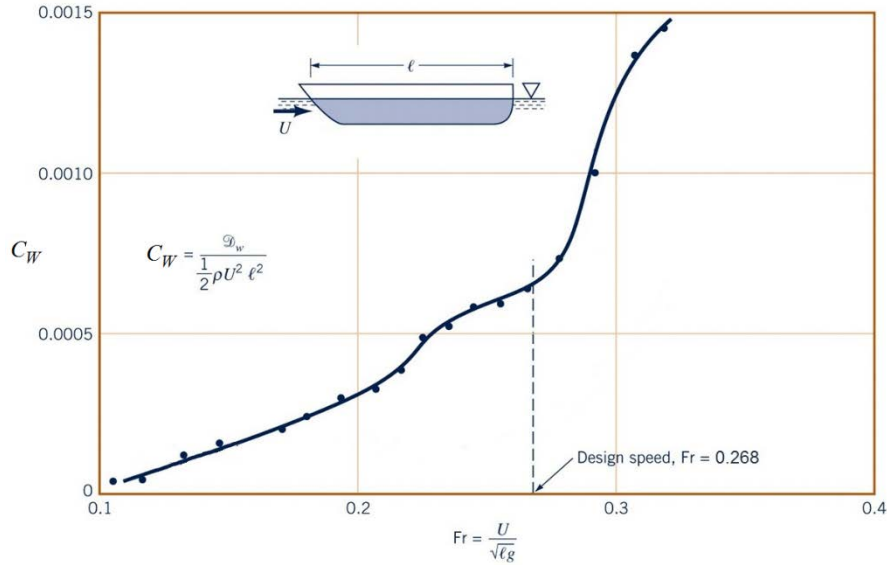

(a) Pi theorem (+4 points)

| | | | | |
|----------------|---------|---------------|------------------|---------------|
| D_w | ℓ | U | ρ | g |
| $\{MLT^{-2}\}$ | $\{L\}$ | $\{LT^{-1}\}$ | $\{ML^{-3}\}$ | $\{LT^{-2}\}$ |
| $\{F\}$ | $\{L\}$ | $\{LT^{-1}\}$ | $\{FT^2L^{-4}\}$ | $\{LT^{-2}\}$ |

$$r = n - m = 5 - 3 = 2$$

$$\Pi_1 = \ell^a U^b \rho^c D_w \doteq (L)^a (LT^{-1})^b (ML^{-3})^c (MLT^{-2}) \doteq M^0 L^0 T^0$$

(or $\doteq (L)^a (LT^{-1})^b (FT^2L^{-4})^c (F) \doteq F^0 L^0 T^0$)

$$\Rightarrow a = -2, \quad b = -2, \quad c = -1$$

$$\therefore \Pi_1 = \ell^{-2} U^{-2} \rho^{-1} D_w = \frac{D_w}{\rho U^2 \ell^2}$$

$$\Pi_2 = \ell^a U^b \rho^c g \doteq (L)^a (LT^{-1})^b (ML^{-3})^c (LT^{-2}) \doteq M^0 L^0 T^0$$

(or $\doteq (L)^a (LT^{-1})^b (FT^2L^{-4})^c (LT^{-2}) \doteq F^0 L^0 T^0$)

$$\Rightarrow a = 1, \quad b = -2, \quad c = 0$$

$$\therefore \Pi_2 = \ell^1 U^{-2} \rho^0 g = \frac{g\ell}{U^2}$$

(b) Similarity requirement (+2 points)

$$\frac{g\ell_m}{U_m^2} = \frac{g\ell}{U^2}$$

$$U = 16.3 \times 0.5144 = 8.385 \text{ m/s}$$

$$\ell_m = \frac{100}{25} = 4 \text{ m}$$

$$\therefore U_m = U \sqrt{\frac{\ell_m}{\ell}} = (16.3 \times 0.5144) \sqrt{\frac{1}{25}} = \mathbf{1.677 \text{ m/s}}$$

(c) Wave-making drag (+4 points)

Model:

$$Fr = \frac{U}{\sqrt{g\ell}} = \frac{1.677}{\sqrt{(9.81)(100/25)}} = 0.268$$

$$C_W = 0.00065 \text{ from the chart}$$

$$\therefore D_w = \frac{1}{2} \rho_m U_m^2 \ell_m^2 \cdot C_W = \left(\frac{1}{2}\right) (999)(1.677)^2 (4)^2 (0.00065) = \mathbf{14.6 \text{ N}}$$

Prototype:

$$Fr = \frac{U}{\sqrt{g\ell}} = \frac{8.385}{\sqrt{(9.81)(100)}} = 0.268$$

$$C_W = 0.00065 \text{ from the chart}$$

$$\therefore D_w = \frac{1}{2} \rho U^2 \ell^2 \cdot C_W = \left(\frac{1}{2}\right) (1,030)(8.385)^2 (100)^2 (0.00065) = \mathbf{235 \text{ kN}}$$