

DATA SHEET

GENERAL Circulators and isolators

1998 Feb 20

Supersedes data of July 1994
File under Professional Components, PC06

Circulators and isolators

GENERAL

INTRODUCTION

This Data Handbook gives only a selection of circulators and isolators from our production line which, we think, are of common interest and which shows our capability. Should you require other executions, different connectors, different frequencies or any other data, please contact us.

Circulators and isolators are key elements in modern VHF, UHF, and microwave engineering. Their fundamental property of non-reciprocity is capable of simplifying the construction and improving the stability, efficiency and accuracy of radar, communication and testing systems, and industrial heating applications.

The devices contain a core of ferrite material biased by a static magnetic field. This field orients the electron spins within the ferrite to produce a gyromagnetic effect. The

non-reciprocal behaviour occurs when a RF signal, applied perpendicular to the biasing field, interacts with the precessing electrons to set up a standing-wave pattern within the core.

CIRCULATORS

A circulator is a passive non-reciprocal device with three or more ports. Energy introduced into one port is transferred to an adjacent port, the other ports being isolated. Although circulators can be made with any number of ports, the most commonly used are 3-port and 4-port ones, the symbols for which are given in Figs 1 and 2.

Energy entering into port 1 emerges from port 2; energy entering into port 2 emerges from port 3, and so on in cyclic order.

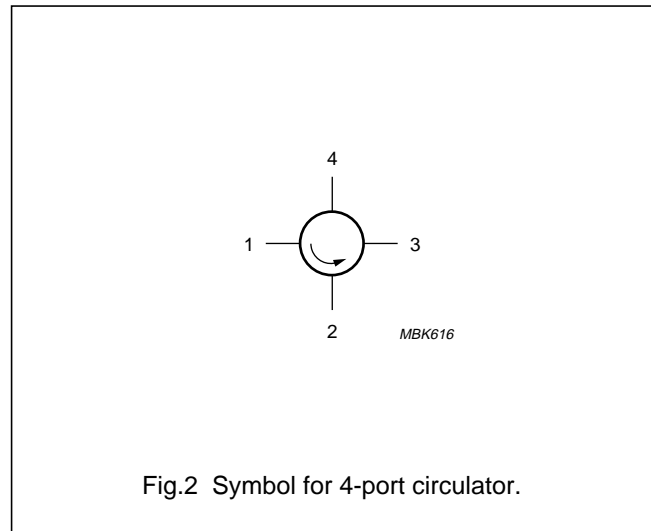
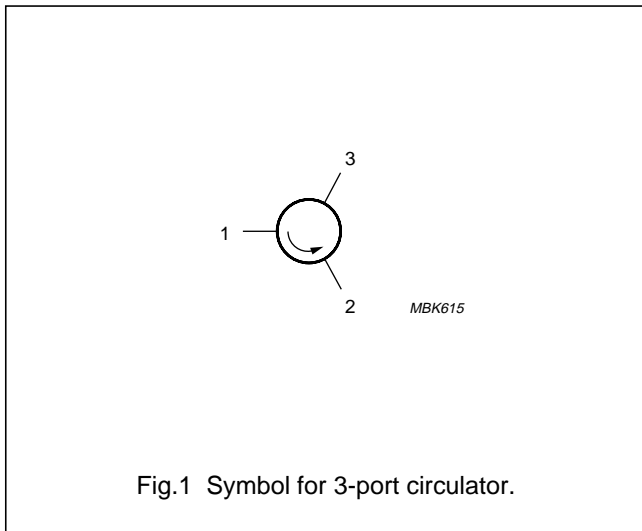

ISOLATORS

An isolator is a passive non-reciprocal 2-port device which permits RF energy to pass through it in one direction whilst absorbing energy in the reverse direction.

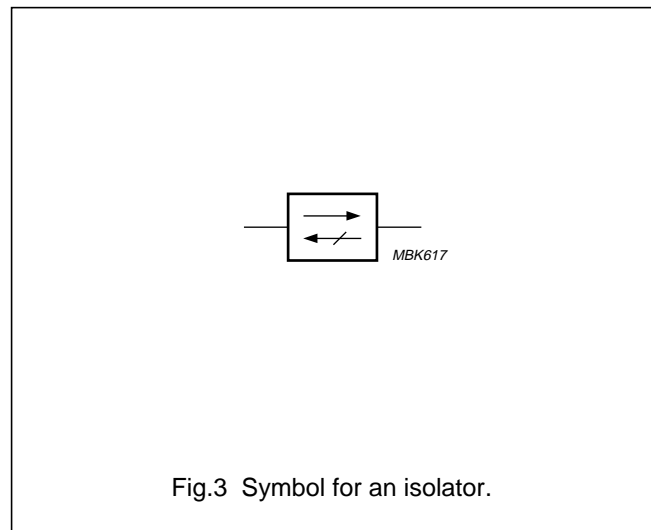

TERMS AND DEFINITIONS**Frequency range**

This is the range within which the circulator or isolator meets the guaranteed specification.

Isolation

In a circulator, isolation is the ratio, expressed in dB, of the power entering a port to the power scattered into the adjacent port on the side opposed to the normal circulation (matched source and the other ports correctly terminated).

In an isolator, isolation is the ratio, expressed in dB, of the input power to the output power for signal injection in the reverse direction (matched source and load).

Insertion loss

The attenuation that results from including the device in the transmission system. It is given as a power ratio, expressed in dB, which compares the situation before and after the insertion of a circulator/isolator (matched source and the other ports correctly terminated).

Maximum power

In a circulator, the maximum power is the largest power it can handle at sea level and at maximum ambient temperature when one port is terminated with a mismatch giving a VSWR of 2, whilst the next port is matched with a VSWR of 1.2 or less, unless otherwise stated. This power value must not be exceeded. If the mismatch of the load is expected to exceed a VSWR of 2, a circulator of higher power handling capacity should be used.

The maximum power is the maximum continuous-wave power unless a maximum peak power is separately stated. If this value is exceeded the circulator can be damaged by arcing in its internal transmission structure. Power values are valid for one signal passage only. If more than one signal passes through the circulator, the peak power of the combined signal should not exceed the indicated maximum peak power.

In an isolator, the maximum power is the largest power that may be passed through it in the forward direction into a load with a VSWR of 2, unless otherwise stated. This power value must not be exceeded.

Temperature range

The ambient temperature range within which circulators and isolators function to specification. (When necessary, special temperature compensation is built in for

circulators.) Circulators still function outside the temperature range but their electrical behaviour may then be far outside the guaranteed specifications. However, no permanent damage can be expected unless a large temperature rise is caused by excessive power handling.

CAUTIONARY NOTES

Circulators and isolators have internal fields that are carefully adjusted for optimum operation; they should not, therefore, be subjected to strong external magnetic fields. During storage and transport a minimum distance of 10 mm to other circulators/isolators and ferromagnetic material is recommended. During operation this distance should be at least 20 mm.

Care must be taken that condensation of humidity, especially in water-cooled items, does not occur.

QUALITY GUARANTEE

Subject to the Conditions of Guarantee the Manufacturer guarantees that circulators and isolators supplied to the purchaser meet the specifications published in the Manufacturer's Data Handbook and are free from defects in material and workmanship.

STANDARD TEST SPECIFICATIONS**Initial measurements**

These measurements have been carried out at room temperature and at the extreme temperatures, with a power level not exceeding 10 mW.

Tropical test

This test has been carried out completely in accordance with IEC 68 test D, accelerated damp heat. This test begins with the temperature at 55 ± 2 °C and R.H. at 95 to 100% for a period of 16 hours, followed by a period of 8 hours with the temperature at + 25 °C and R.H. 80 to 100% to complete the 24-hour cycle: the test consists of 6 uninterrupted cycles.

Vibration test

This test has been carried out completely in accordance with MIL-STD-202D, method 201A: frequency range 10 to 55 to 10 Hz for 2 hours in each of the X, Y and Z directions, with a total excursion of 1,5 mm.

Circulators and isolators

GENERAL

Thermal shock test

This test has been carried out completely in accordance with MIL-STD-202D, method 107C under condition A: 5 cycles with extreme temperatures of $-55\text{ }^{\circ}\text{C}$ and $+85\text{ }^{\circ}\text{C}$; each cycle of 1 hour's duration.

Mechanical shock test

This test has been carried out in accordance with MIL-STD-202D, method 213A under condition G: peak value 100 g, duration 6 ms, and also with extreme peak values up to 800 g, duration approximately 1 ms for each device, referring to the results of the drop test.

Drop test

This test has been carried out in accordance with ISO 2248, part IV: packaging complete, filled transport packages, vertical impact.

RF power test

The devices have been tested in accordance with the definition of maximum power in the Data Handbook (VSWR = 2). The ambient temperature of $25\text{ }^{\circ}\text{C}$ was increased to the maximum operating temperature and the duration of the test was 1 hour for each device.

Final measurements

On completion of the above tests final measurements were carried out at a temperature of $+25\text{ }^{\circ}\text{C}$ and with a power level not exceeding 10 mW. The results of these tests should be within the guaranteed values.

Dimensions and visual appearance

These have been checked in accordance with the published data.

Note

On request, different tests and/or additional tests to those above can be carried out.

12-digit type number

Each device is uniquely identified by a 12-digit type number, the last three digits being specific device identifiers. The diagram below shows you how, from the first nine digits, to find the circulator, isolator or isoductor you need. Remember that devices with alternative connectors and operating at other frequencies may be available on request.

DIGITS	DIGITS	DIGITS		
1 - 4	5 - 7	8 AND 9		
	161 (waveguide)	0 1 0 2 0 3 0 4	=	field displacement or slimline isolator circulator X-configuration, 4-port circulator isolator
2722	162 (coaxial)	0 1, 3, 5, 7 0 2, 6, 8 0 4 0 9	=	circulator isolator 4-port circulator isoductor
	163 (industrial)	0 1 0 2	=	circulator isolator

APPLICATIONS

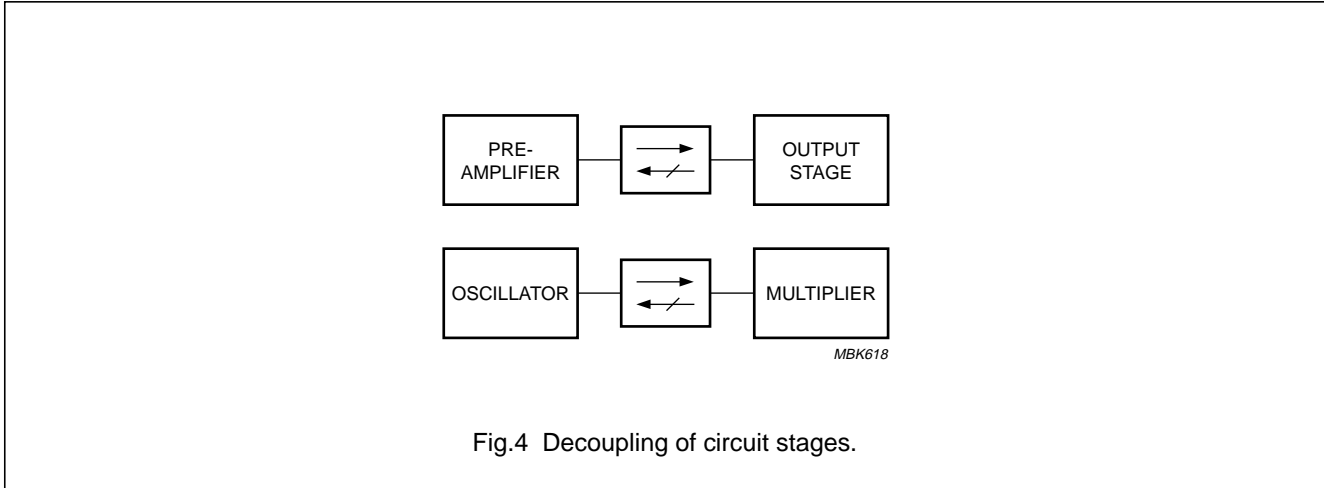

Fig.4 Decoupling of circuit stages.

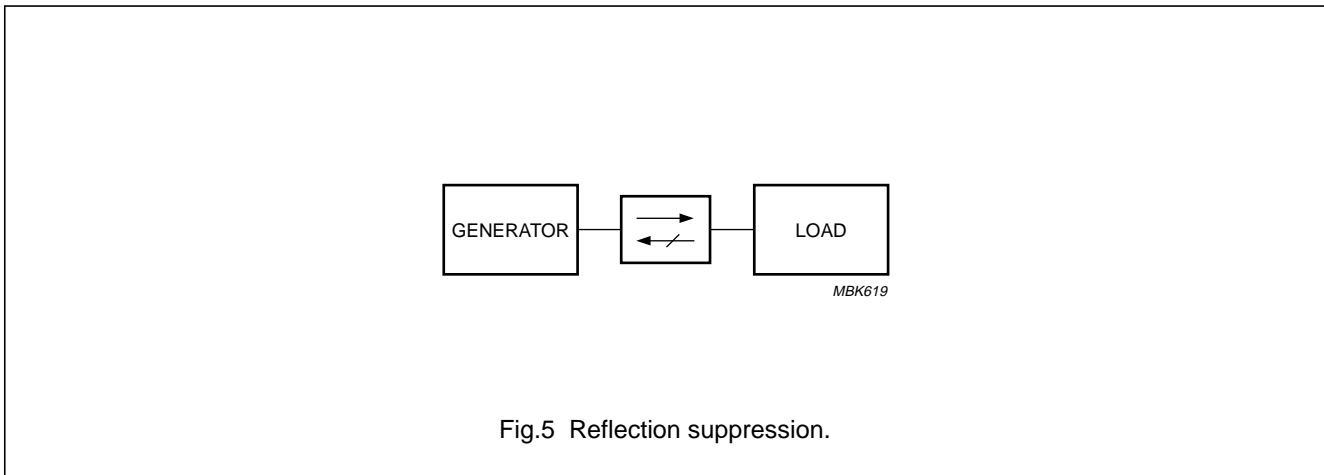

Fig.5 Reflection suppression.

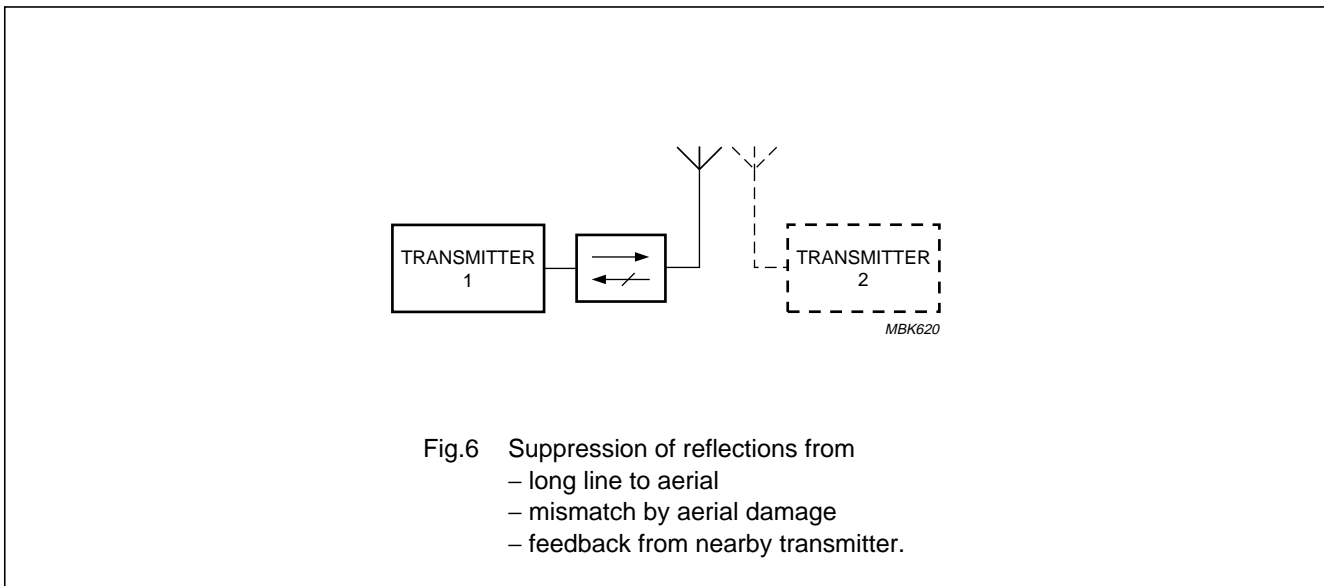

Fig.6 Suppression of reflections from
– long line to aerial
– mismatch by aerial damage
– feedback from nearby transmitter.

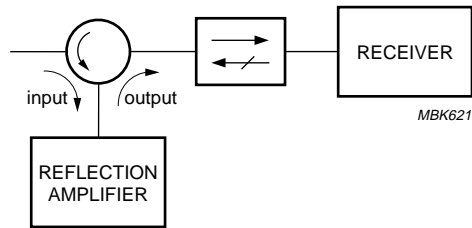

Fig.7 Separate input and output of a reflection amplifier, such as parametric amplifiers; tunnel, Gunn or Impatt diode amplifiers.

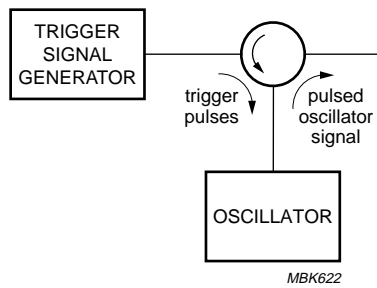

Fig.8 Feed trigger signals into an oscillator.

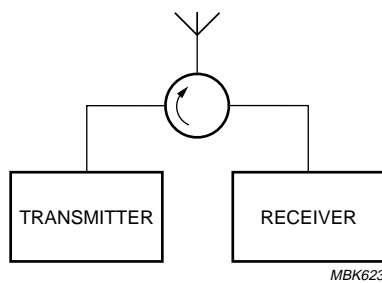

Fig.9 Avoid separate aerial for transmitter and receiver.

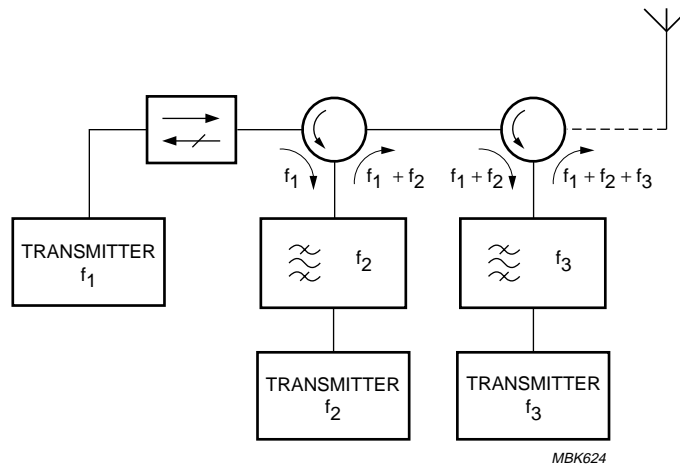

Fig.10 Connect different transmitters to a common aerial.

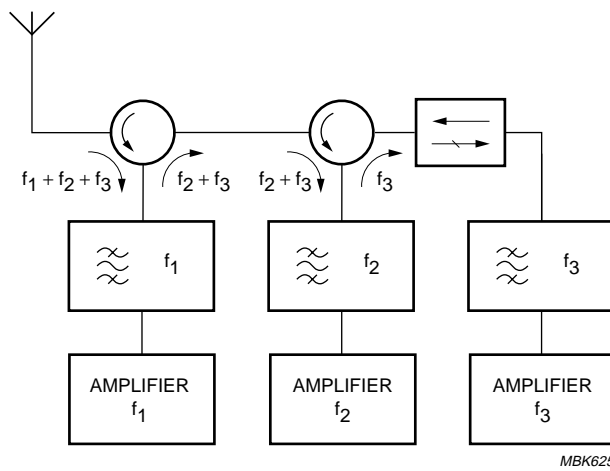
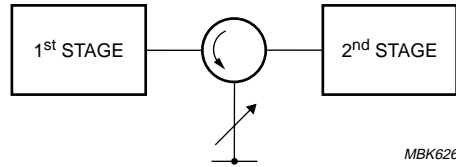
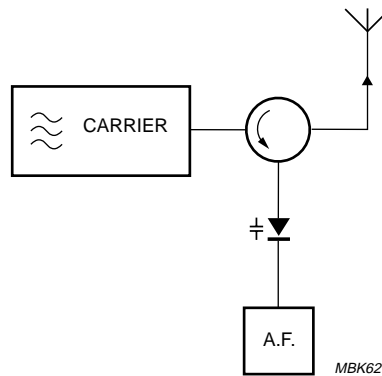

Fig.11 Separate a range of frequencies received by a common aerial.



MBK626

Fig.12 Variable phase shifters with a variable short-circuit.



MBK627

Fig.13 Phase modulation with a variable capacitance diode as a variable reactance.

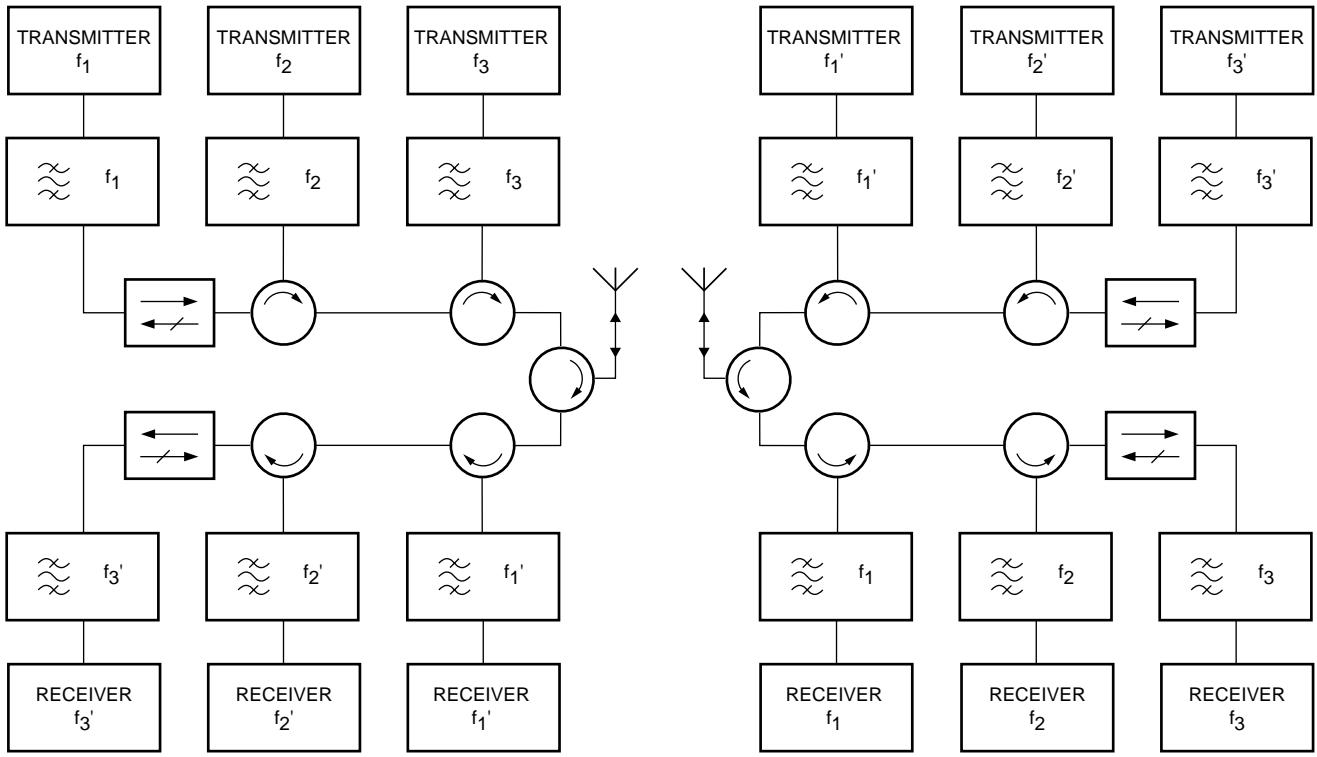

Fig.14 Signal combination and separation used together in a frequency-multiplexed, multi-channel transceiver system.