









Network Models & Applications --an overview





This Hypercard stack was prepared by:
Dennis Bricker,
Dept. of Industrial Engineering,
University of Iowa,
Iowa City, Iowa 52242
e-mail: dbricker@icaen.uiowa.edu

A SAMPLING OF THE PROBLEMS



-  *Shortest Route Problem*
-  *Maximum Flow Problem*
-  *Minimum Spanning Tree Problem*
-  *Transportation Problem*
-  *Minimum-Cost Network Flow Problem*



-  *"Classical" (Linear) Assignment Problem*
-  *Generalized Assignment Problem*
-  *Quadratic Assignment Problem*

location problems

-  *Facility Location in the Plane (mini-sum)*
-  *Facility Location on a Network (mini-sum)*
-  *Facility Location on a Network (mini-max)*

routing problems

-  *The Traveling Salesman Problem*
-  *The Chinese Postman Problem*
-  *Vehicle Routing Problem*

-  *Job Sequencing Problem*
-  *Job Shop Scheduling*
-  *Assembly-Line Balancing Problem*

Shortest Route Problem

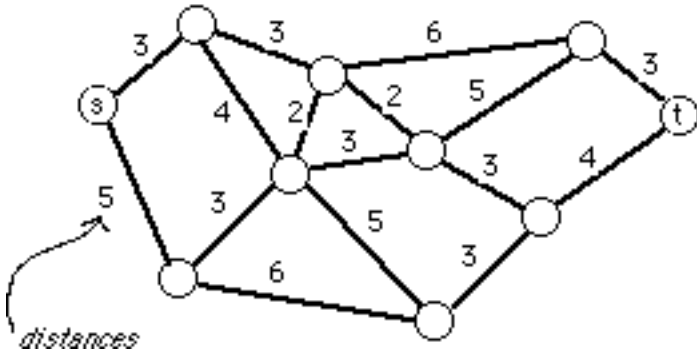

Find the shortest route in the network from node s to node t



Maximum Flow Problem

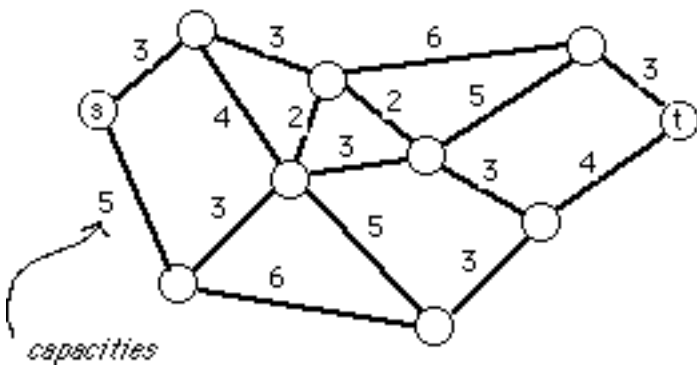

Find the maximum amount of flow in the network from node s to node t



Minimum Spanning Tree Problem

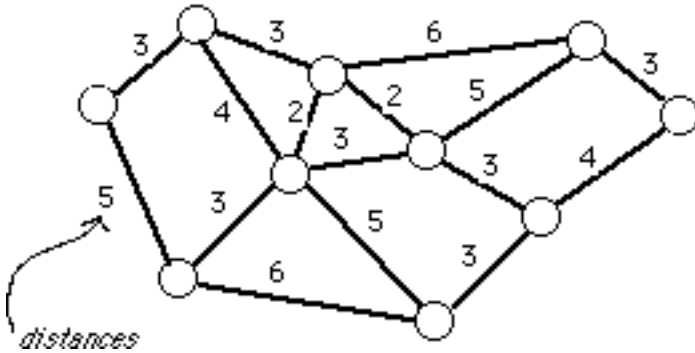

Given a set of facilities and a network representing possible links to be built, what is the set of links with least distance such that every facility can communicate with each of the other facilities?



Transportation Problem

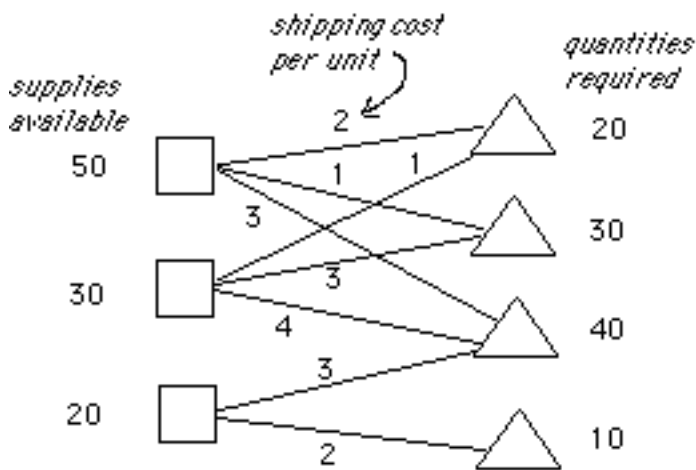

Find the least-cost shipments which will satisfy the given requirements, using the available supplies



Minimum-Cost Network Flow Problem

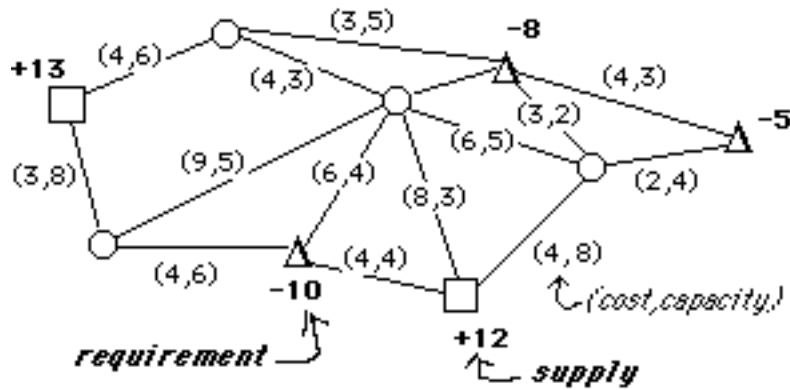

What is the lowest-cost way to ship supplies of goods from supply points to demand points, given a network with specified shipping cost/unit and capacity in each link?



Assignment Problem

		<i>jobs</i>				
		A	B	C	D	E
<i>machines</i>	1	5	3	2	3	4
	2	6	2	1	4	3
	3	4	3	3	2	2
	4	5	4	2	5	2
	5	3	3	2	4	3

cost of completing job

What is the least-cost way of assigning a machine to each of five jobs (one job per machine)?



Generalized Assignment Problem

machine	job					
	A	B	C	D	E	F
1	3	5	2	4	6	3
2	1	3	2	2	4	2
3	2	4	5	1	3	2

cost of completing job

Six jobs are to be assigned to three machines, the cost of completing the job and the time to complete the job depending upon the job & machine.

machine	job						time available
	A	B	C	D	E	F	
1	2	3	1	3	4	1	6 hrs
2	3	5	2	3	3	2	8 hrs
3	5	4	2	4	6	2	8 hrs

time req'd for job (hrs)

What is the least cost assignment, given the time available on each machine?



Quadratic Assignment Problem (facility layout)

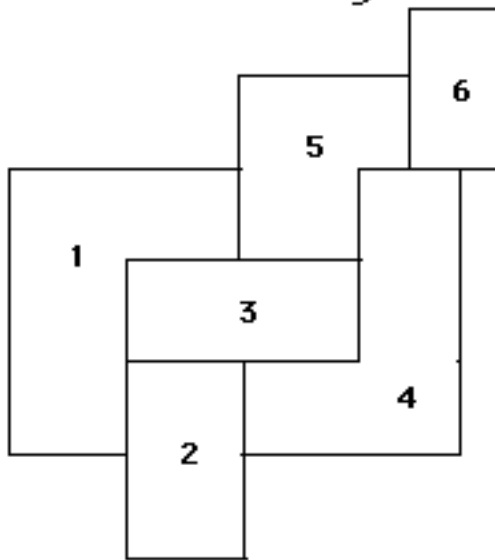

	1	2	3	4	5	6
1	-	1	1	2	1	2
2		-	1	1	2	3
3			-	1	1	2
4				-	1	1
5					-	1
6						-

distance between areas (cost per unit of traffic)

	A	B	C	D	E	F
A	-	3	5	2	1	1
B		-	2	4	2	1
C			-	3	1	0
D				-	4	2
E					-	3
F						-

amount of traffic/day between departments

Place departments A through F in areas 1 through 6 so as to minimize the daily cost of traffic flow.



Facility Location in the Plane (mini-sum)



Where should one locate 2 warehouses so as to minimize the daily cost of satisfying the demands (assuming Euclidean distances & linear costs)?



Facility Location on a Network (mini-sum)

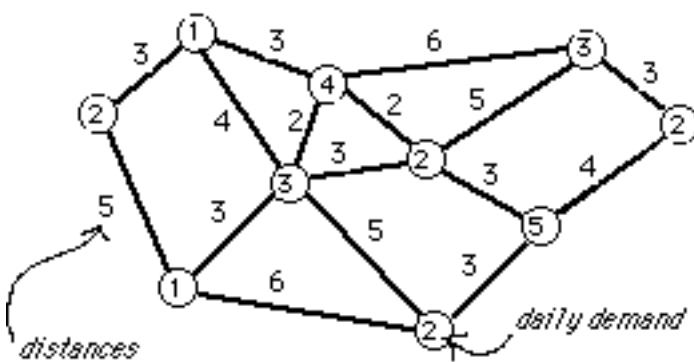

Where on the network should one locate two facilities so as to minimize the daily cost of satisfying the demands? (assuming costs are linear in both distance and quantities shipped)



Facility Location on a Network (mini-max)

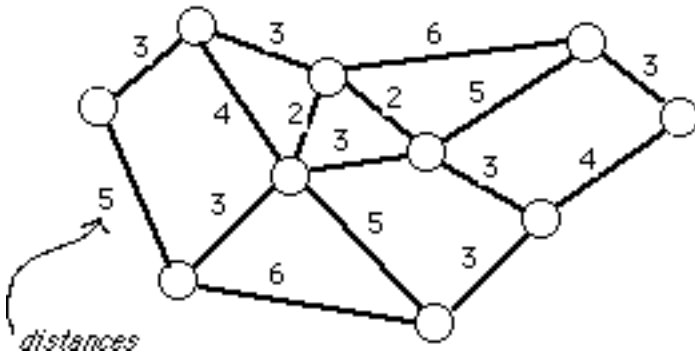

Where on the network should one locate an emergency facility (for example, a fire station) so as to minimize the distance to the furthest node in the network?



The Traveling Salesman Problem

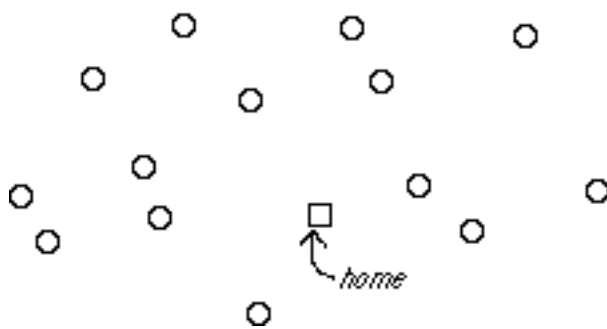

A salesman must visit customers in each of a set of cities. What is the shortest route that visits each city exactly once and returns to his home?



The Chinese Postman Problem

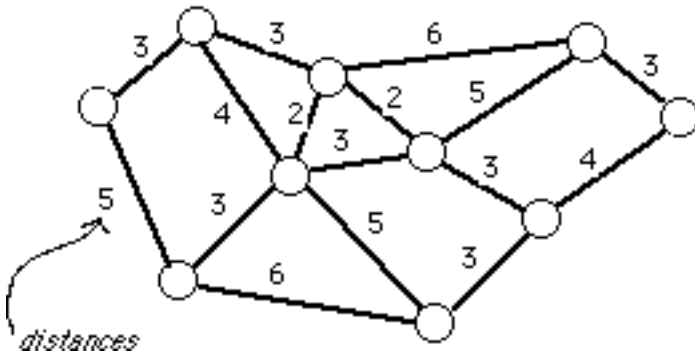

Find the shortest route for a postman who must travel each street in the network at least once.



Vehicle Routing Problem

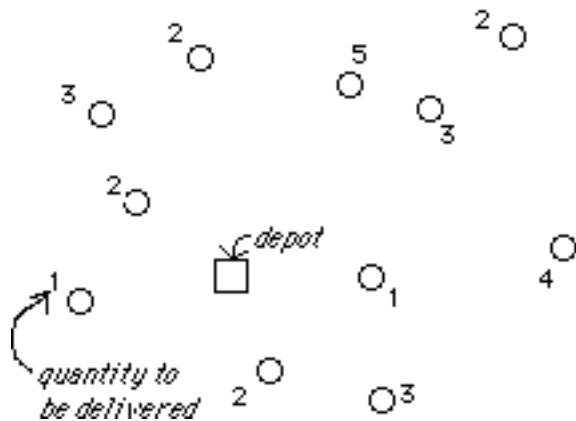

Delivery trucks with a capacity of 8 units are to deliver to customers. What is the lowest cost set of routes? (Assume fixed cost of using truck, plus cost proportional to distance.)



Job Sequencing Problem

		<i>to</i>				
		A	B	C	D	E
<i>from</i>	A	-	3	2	4	3
	B	4	-	4	5	6
	C	5	3	-	4	4
	D	3	5	1	-	6
	E	5	4	2	3	-

Every month, a plastics plant must make batches of five different types of plastic toys.

There is a conversion cost C_{ij} in switching from toy i to toy j .

Find a sequence of toy production (to be used each month) that minimizes the monthly conversion costs.



Job Shop Scheduling

Processing times

Job	machines		
	#1	#2	#3
1	8	2	4
2	5	4	5
3	6	7	3
4	7	3	2

How should 4 jobs be sequenced on 3 machines, so that the total time to complete all jobs is minimized? (Assume no "passing" of one job by another.)

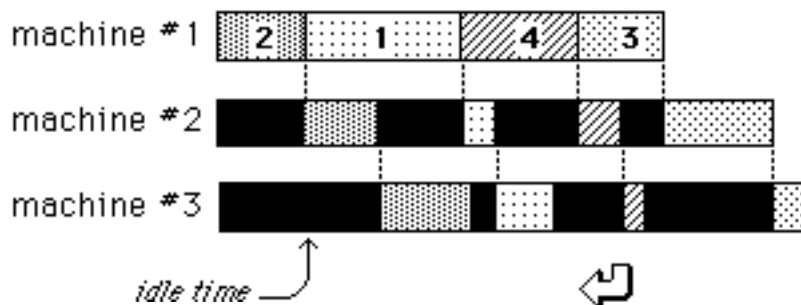

Assembly-Line Balancing Problem

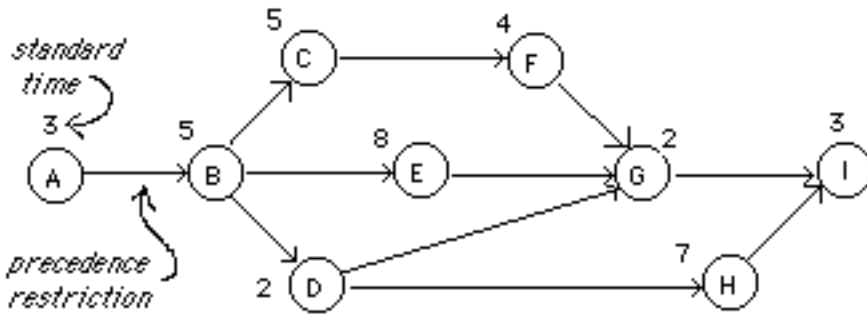

An assembly line is to be designed for a job requiring 9 tasks. The required output of the line is 6/hour.

What is the least number of stations required?

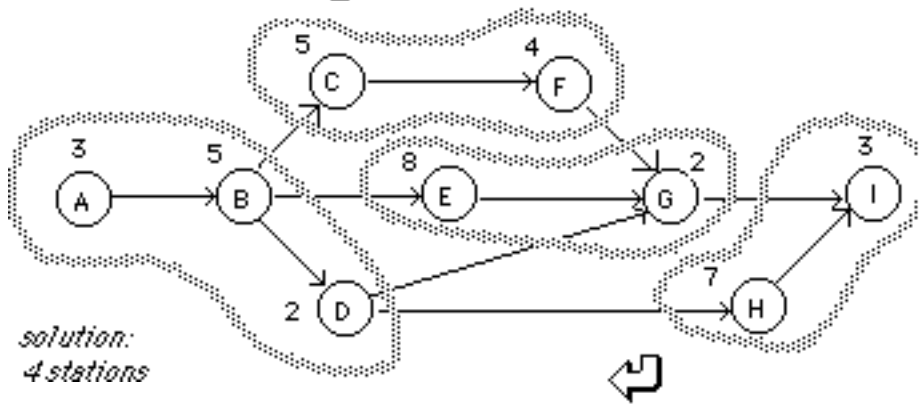

solution:
4 stations