

# The Kilbridge & Wester Heuristic

First, the "layers" are identified in the precedence diagram:

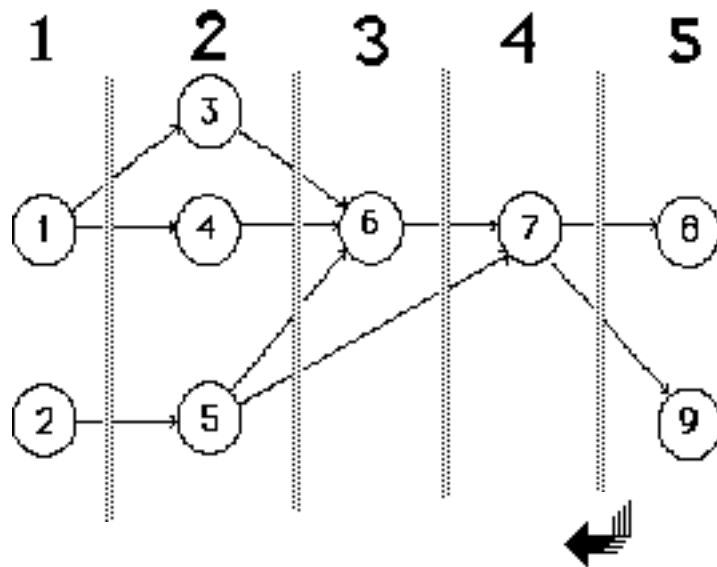

Tasks with NO predecessors are in the first layer.

Tasks that are preceded directly by tasks in layer #i are placed in layer # i+1, etc.

©Dennis Bricker, U. of Iowa, 1997

Compute the cumulative performance times by layer:

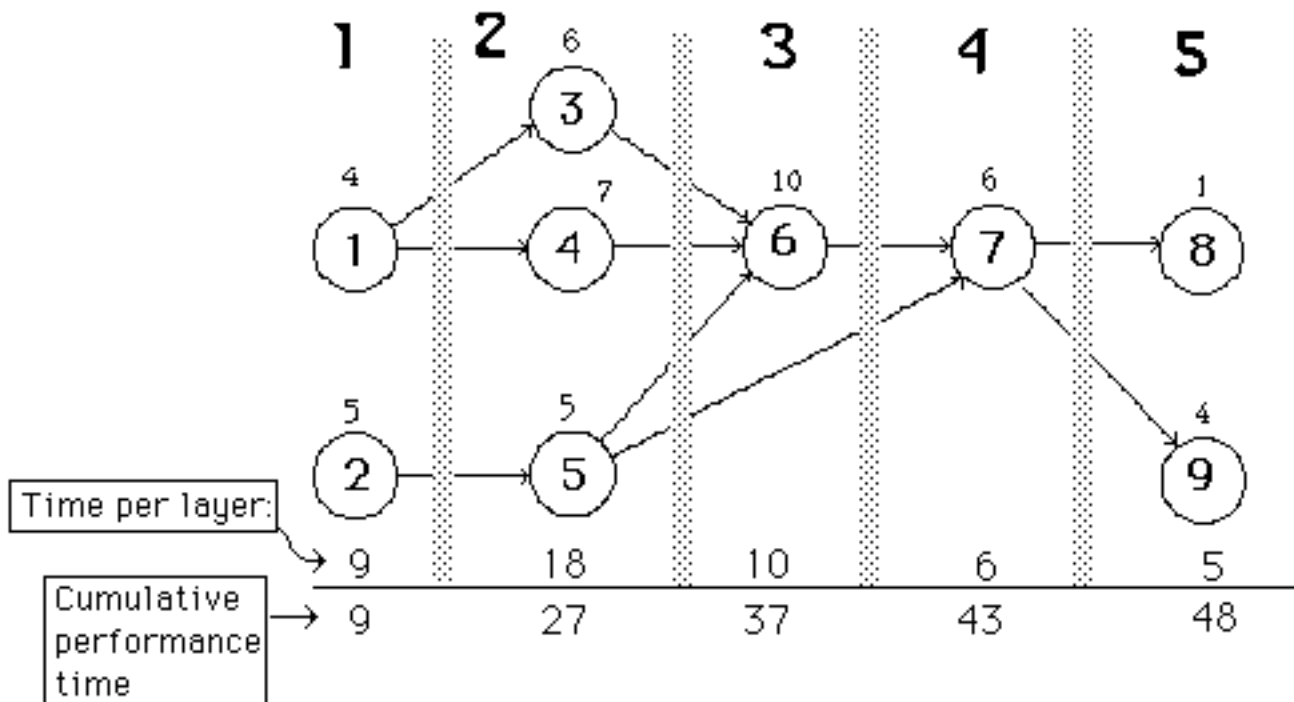

©Dennis Bricker, U. of Iowa, 1997

### Let's find a balance with cycle time $c=16$

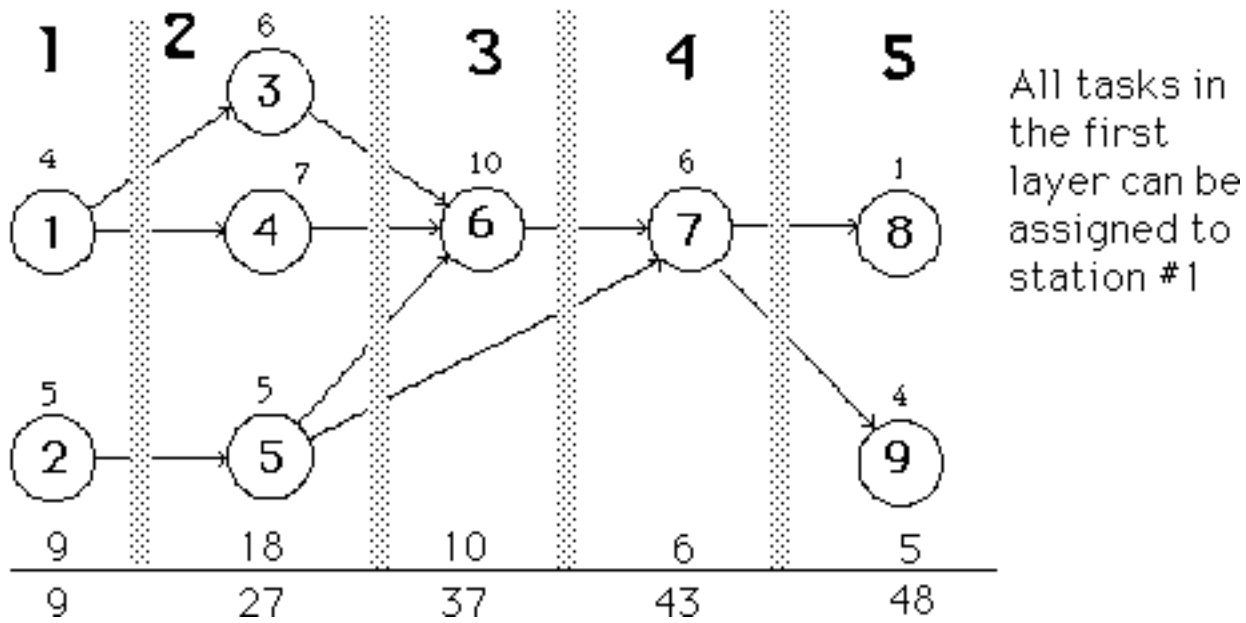

©Dennis Bricker, U. of Iowa, 1997

Only  $16-9=7$  minutes remain idle at station #1, which is not enough to perform all the tasks of layer #2. Find a subset of tasks in layer #2 with total performance time as near as possible to 7:

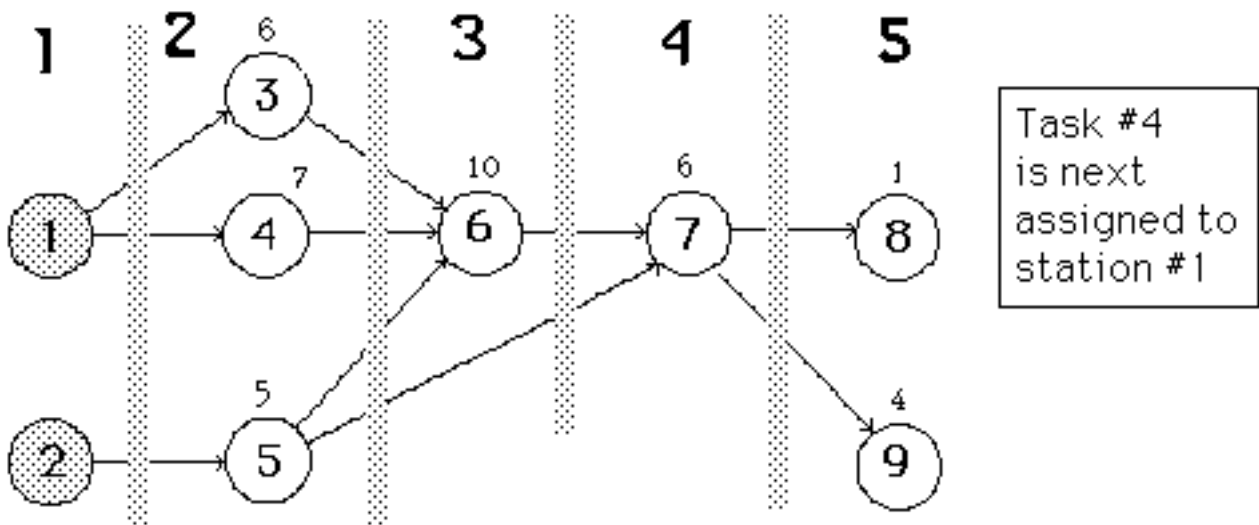

©Dennis Bricker, U. of Iowa, 1997

Recompute the cumulative performance time of the unassigned tasks:

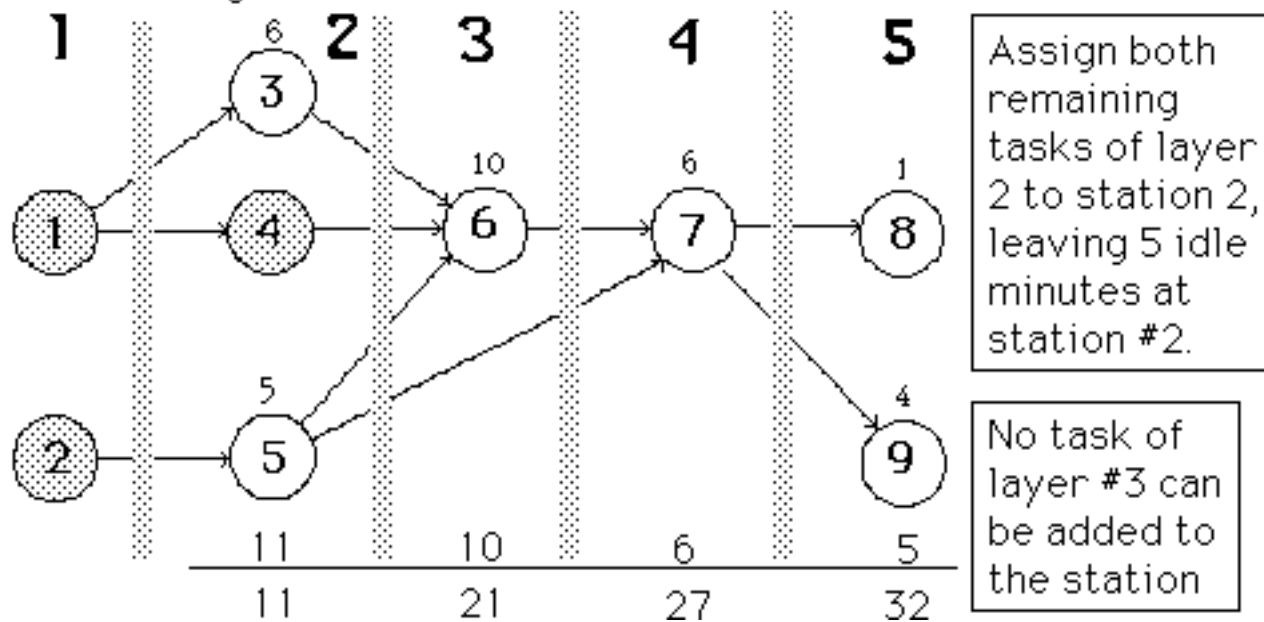

©Dennis Bricker, U. of Iowa, 1997

Recompute the cumulative times for unassigned tasks by layer:

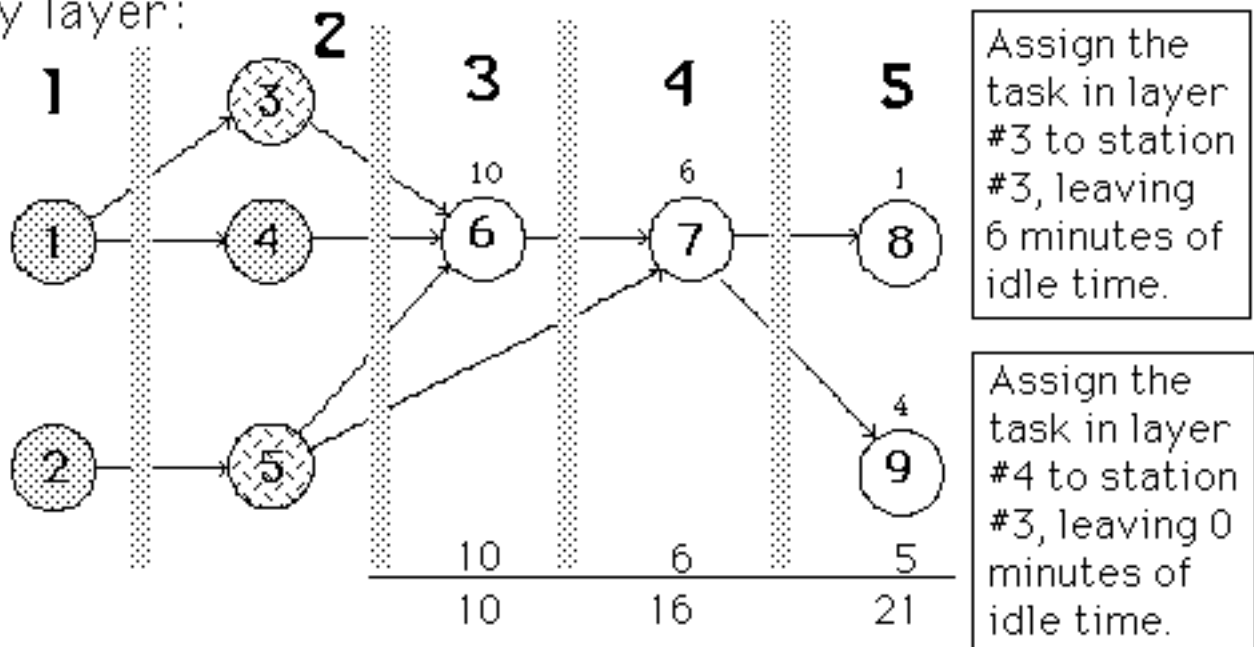

©Dennis Bricker, U. of Iowa, 1997

Recompute cumulative times of unassigned tasks:

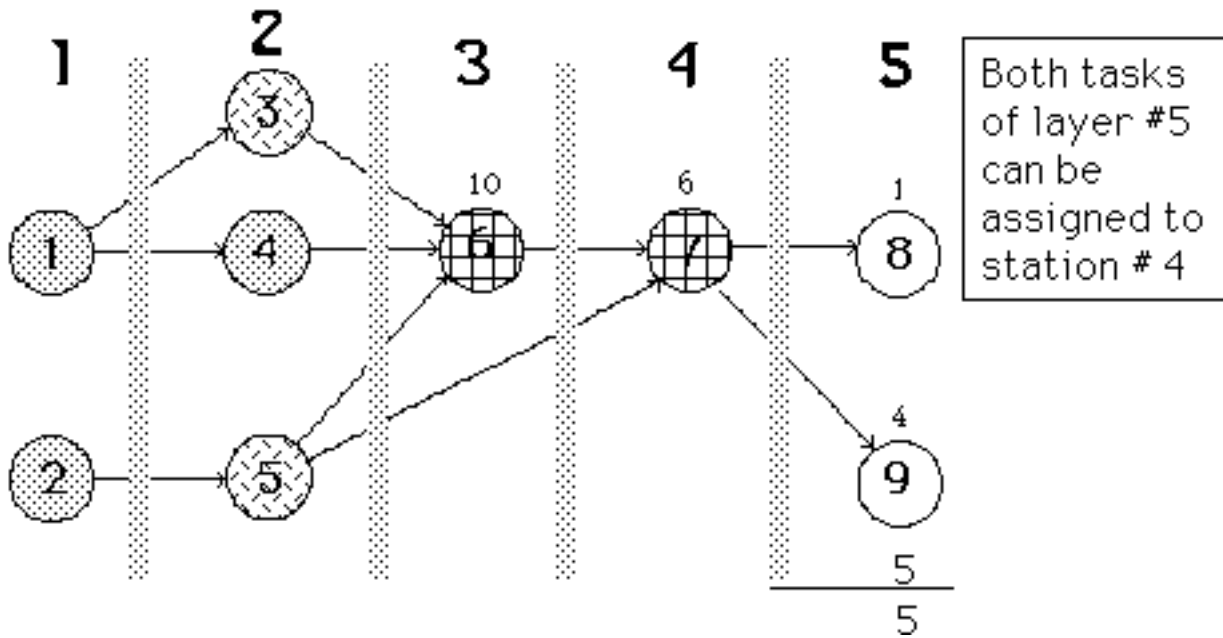

©Dennis Bricker, U. of Iowa, 1997

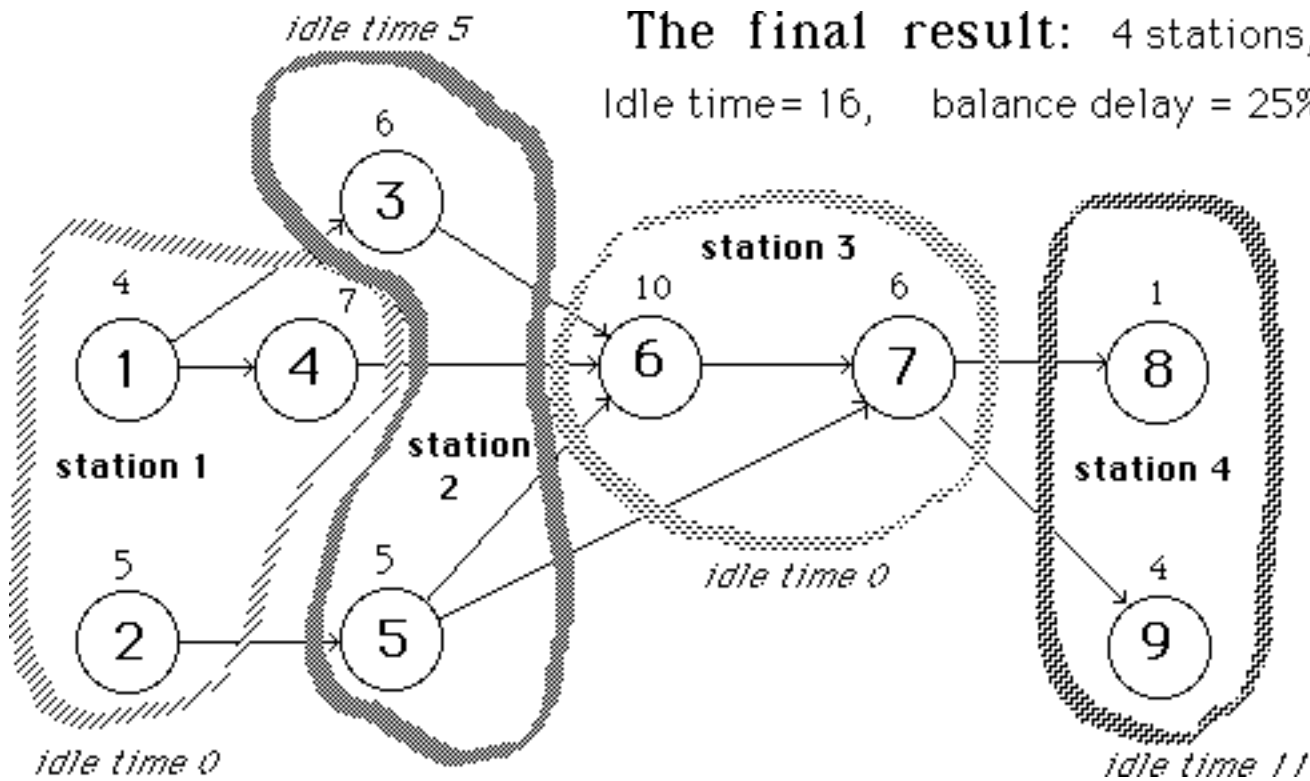

©Dennis Bricker, U. of Iowa, 1997

# Another example: cycle time = 15 minutes

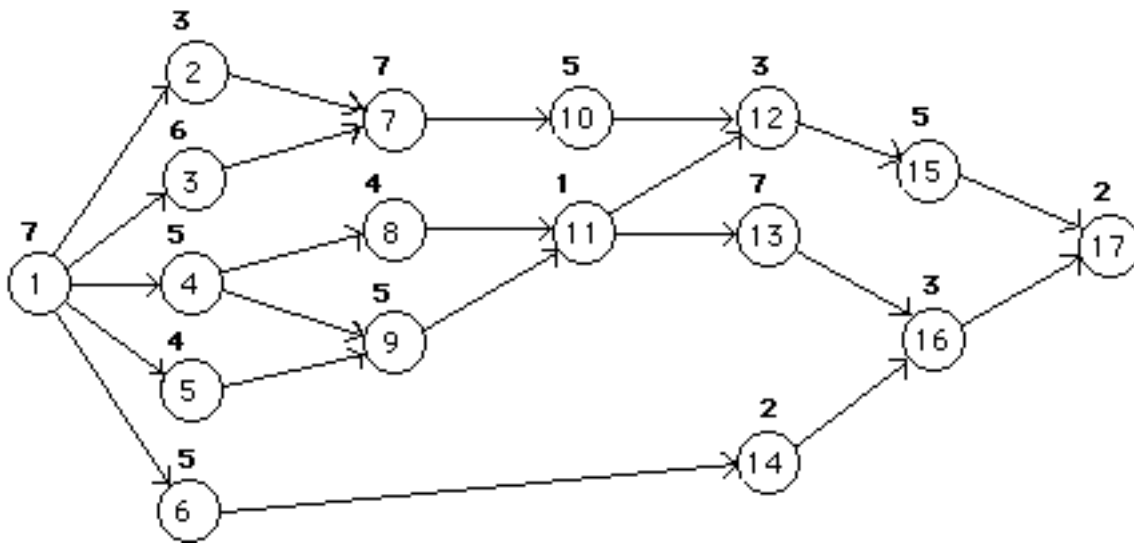

©Dennis Bricker, U. of Iowa, 1997

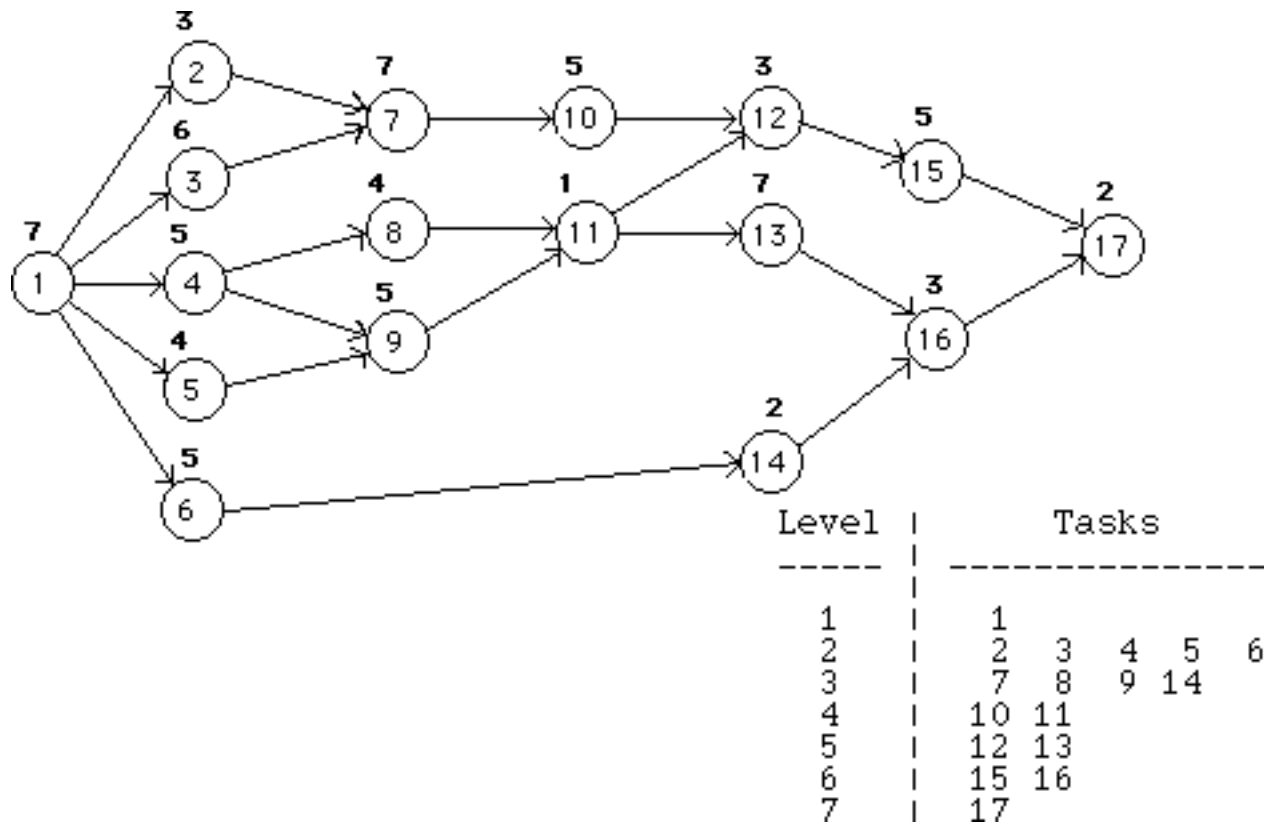

©Dennis Bricker, U. of Iowa, 1997

Kilbridge and Wester's  
Heuristic Method

Station 1

Cumulative P of unassigned tasks by level:

Level	1	2	3	4	5	6	7
Cum P	7	30	48	54	64	72	74

Assign task(s) 1 to station 1

Idle time at Station 1 is now 8

Candidates from level 2 for adding to station 1 are 2 3 4 5 6

Add task(s) 2 6 with total processing time 8

©Dennis Bricker, U. of Iowa, 1997

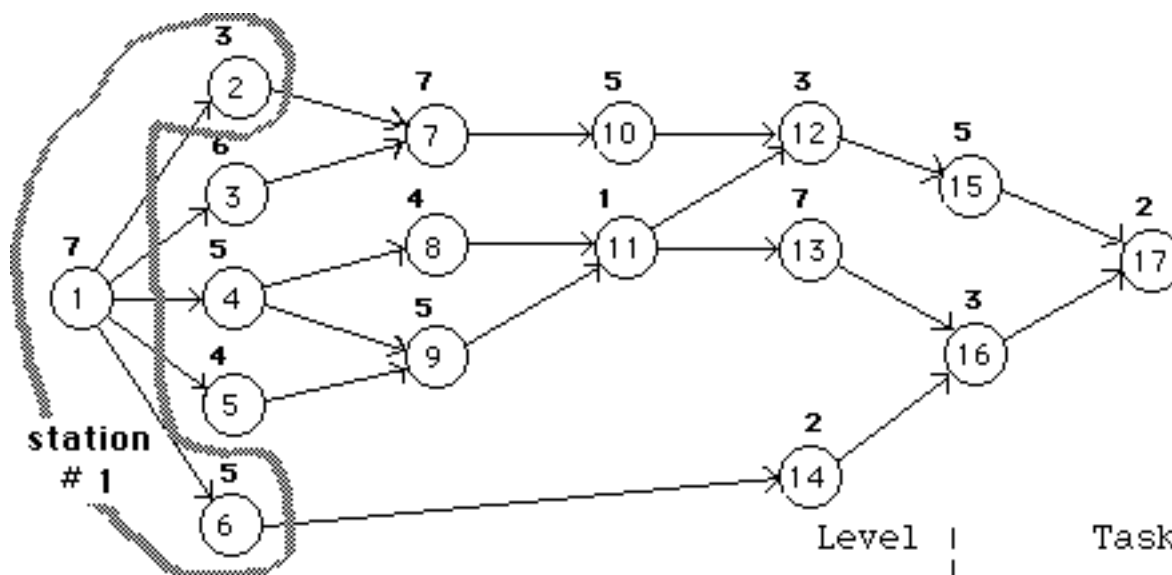

Level	Tasks
1	1
2	2 3 4 5 6
3	7 8 9 14
4	10 11
5	12 13
6	15 16
7	17

©Dennis Bricker, U. of Iowa, 1997

Kilbridge and Wester's  
Heuristic Method

Station 2

Cumulative P of unassigned tasks by level:

Level	1	2	3	4	5	6	7
Cum P	0	15	33	39	49	57	59

Assign task(s) 3 4 5 to station 2

Idle time at Station 2 is now 0

Candidates from level 3 for adding to station 2 are 7 8 9 14

Add task(s) <none> with total processing time 0

©Dennis Bricker, U. of Iowa, 1997

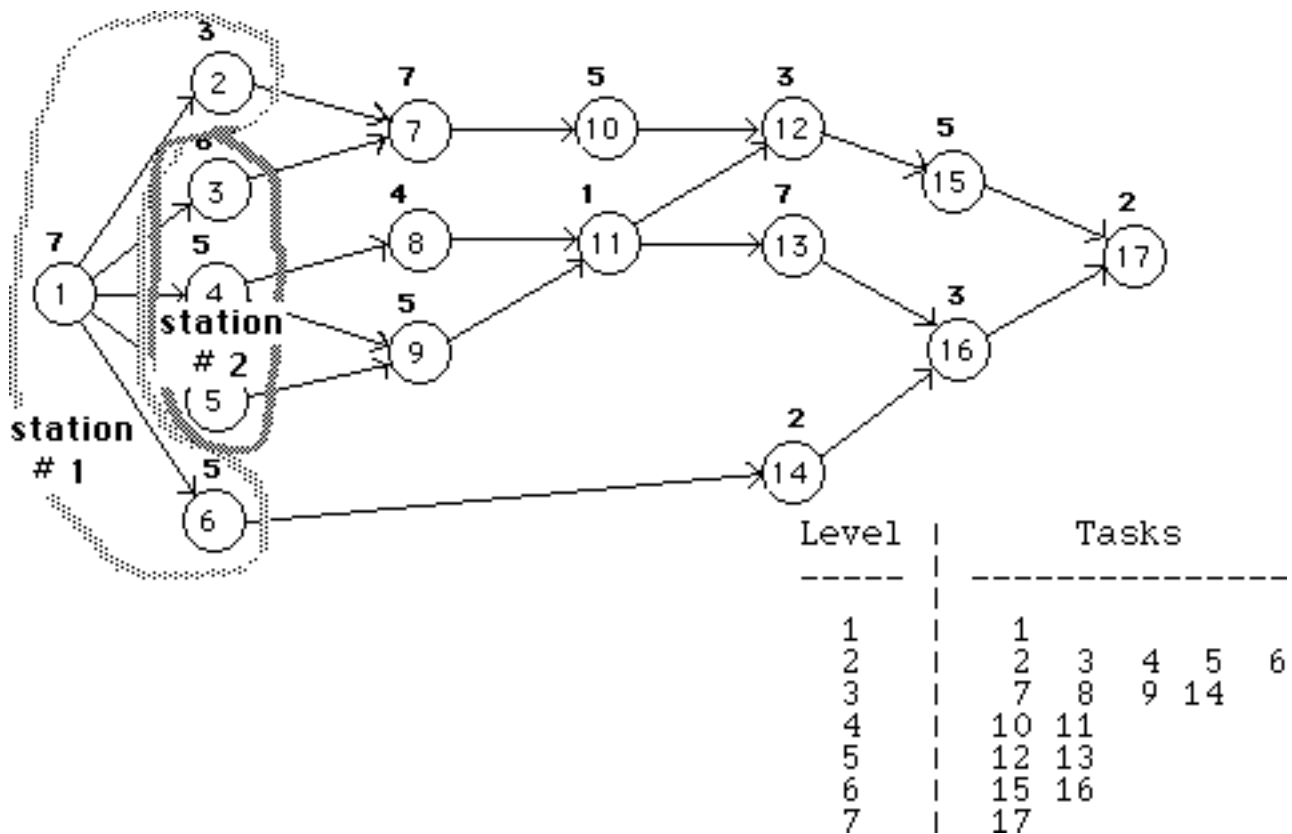

Kilbridge and Wester's  
Heuristic Method

Station 3

Cumulative P of unassigned tasks by level:

Level	1	2	3	4	5	6	7
Cum P	0	0	18	24	34	42	44

Candidates from level 3 for adding to station 3 are 7 8 9 14

Add task(s) 7 9 14 with total processing time 14

©Dennis Bricker, U. of Iowa, 1997

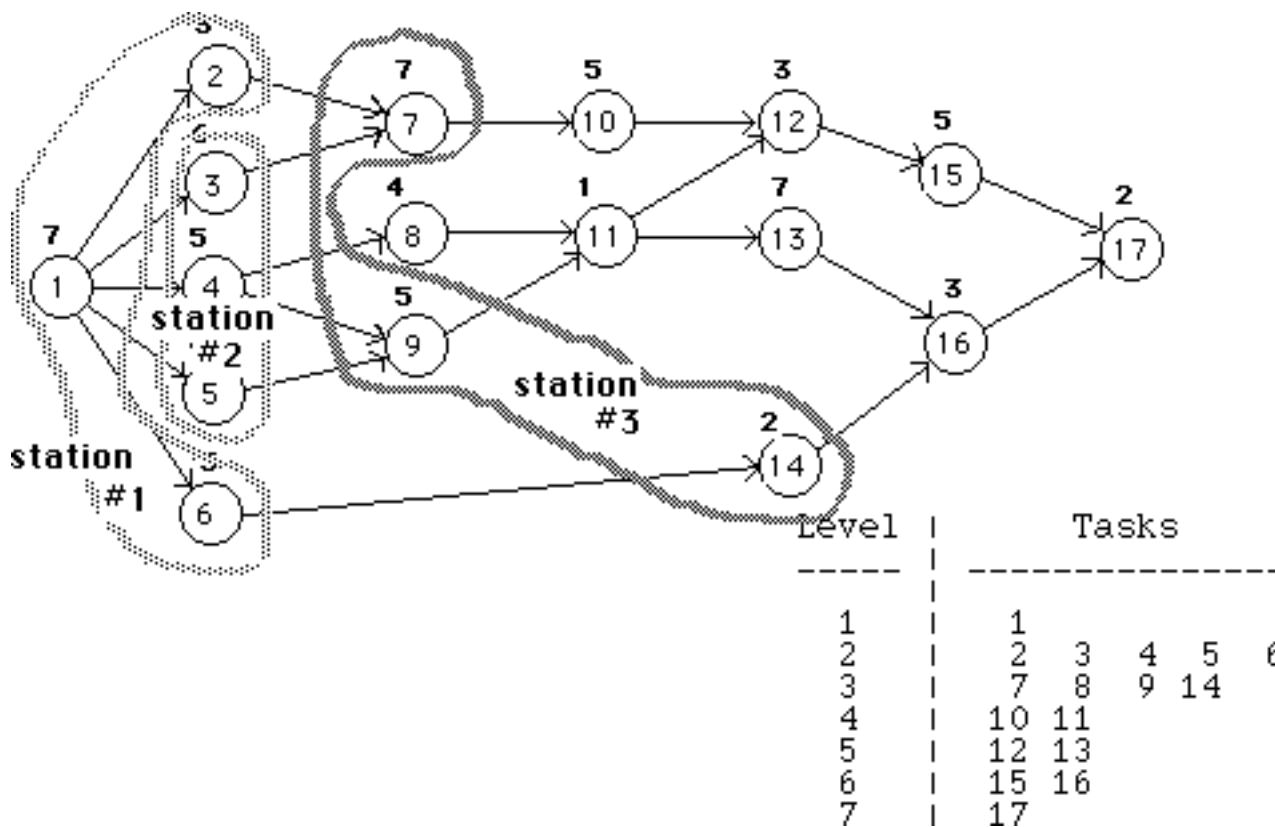

©Dennis Bricker, U. of Iowa, 1997



Kilbridge and Wester's  
Heuristic Method

Station 4  
-----

Cumulative P of unassigned tasks by level:

Level	1	2	3	4	5	6	7
Cum P	0	0	4	10	20	28	30

Assign task(s) 8 10 11 to station 4

Idle time at Station 4 is now 5

Candidates from level 5 for adding to station 4 are 12 13

Add task(s) 12 with total processing time 3

©Dennis Bricker, U. of Iowa, 1997

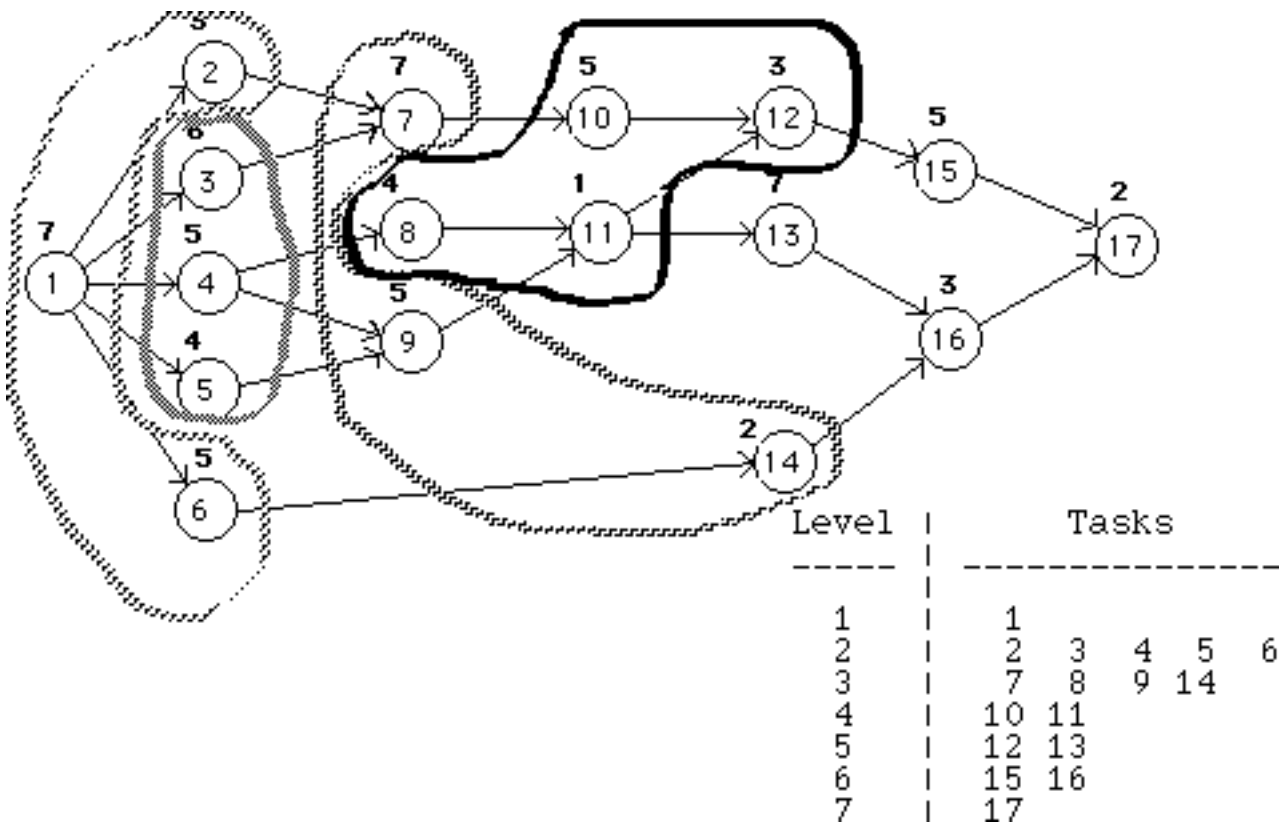

©Dennis Bricker, U. of Iowa, 1997

Kilbridge and Wester's  
Heuristic Method

Station 5

Cumulative P of unassigned tasks by level:

Level	1	2	3	4	5	6	7
Cum P	0	0	0	0	7	15	17

Assign task(s) 13 15 16 to station 5

Idle time at Station 5 is now 0

Candidates from level 7 for adding to station 5 are 17

Add task(s) <none> with total processing time 0

©Dennis Bricker, U. of Iowa, 1997

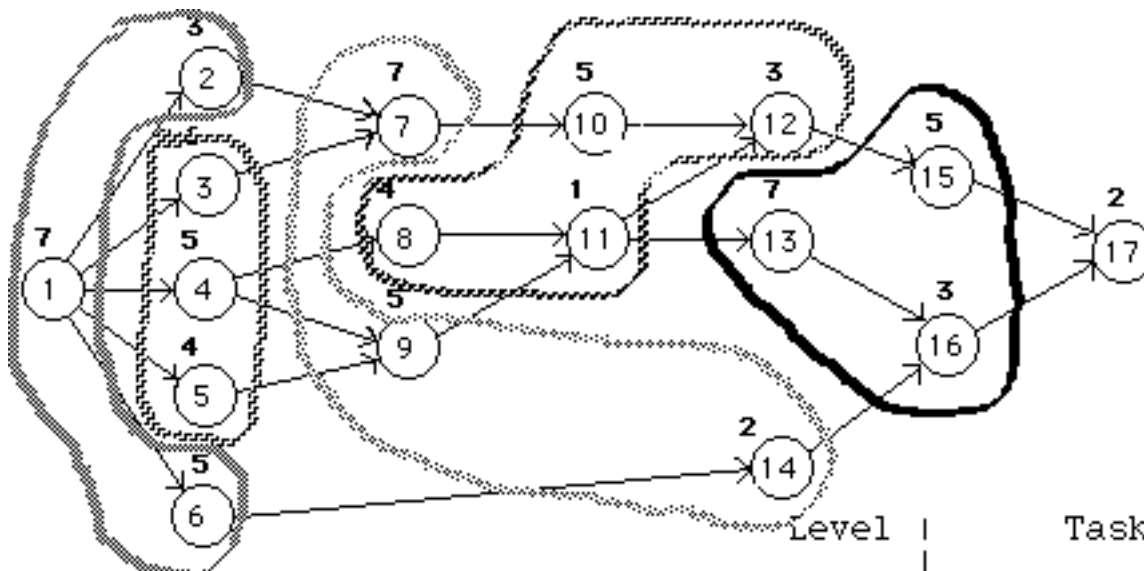

Level	Tasks
1	1
2	2 3 4 5 6
3	7 8 9 14
4	10 11
5	12 13
6	15 16
7	17

©Dennis Bricker, U. of Iowa, 1997

Kilbridge and Wester's  
Heuristic Method

Station 6

Cumulative P of unassigned tasks by level:

Level	1	2	3	4	5	6	7
Cum P	0	0	0	0	0	0	2

Assign task(s) 17 to station 6

Idle time at Station 6 is now 13

Candidates from level 8 for adding to station 6 are

Add task(s) <none> with total processing time 0

\*\*\*Done\*\*\*

©Dennis Bricker, U. of Iowa, 1997

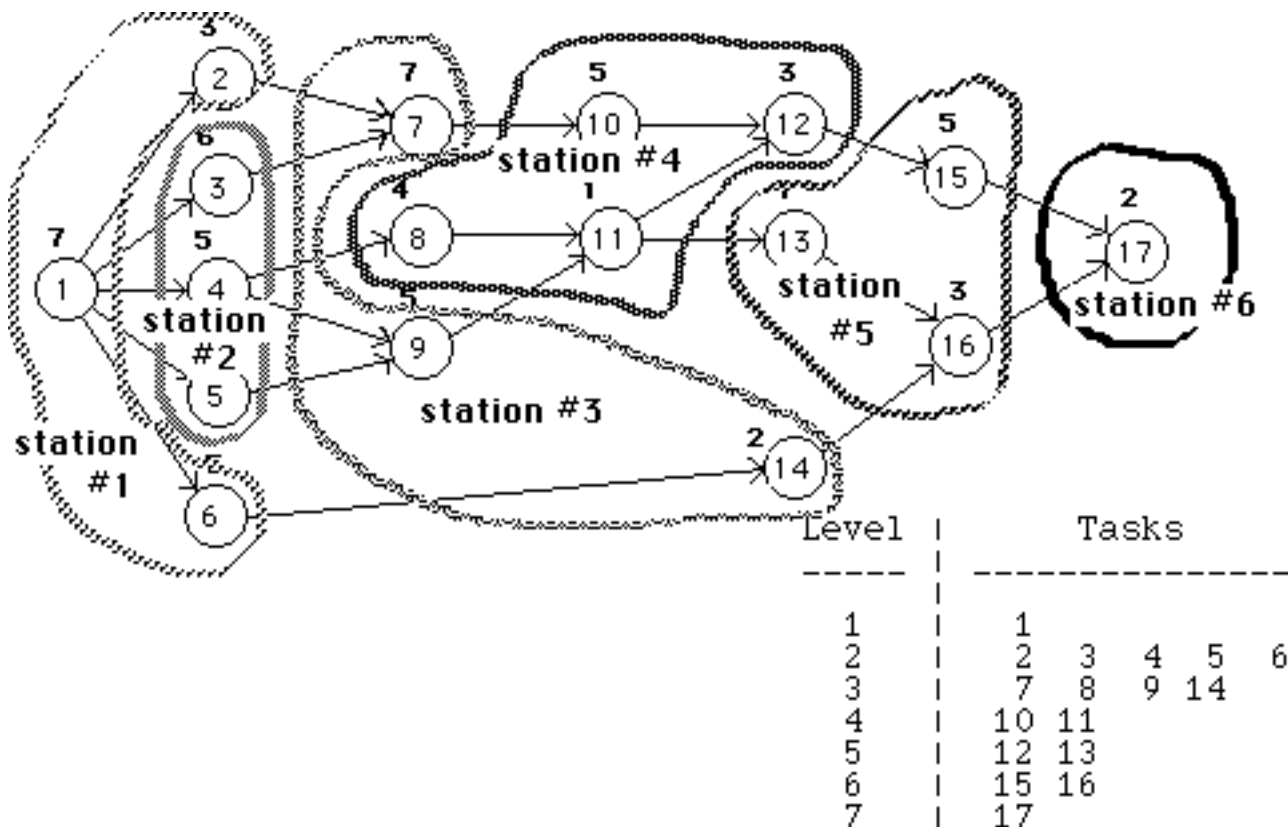

©Dennis Bricker, U. of Iowa, 1997

Solution
----------

17-task Line-Balancing Problem

Number of Stations: 6

Station	Idle time	Tasks
1	0	1 2 6
2	0	3 4 5
3	1	7 9 14
4	2	8 10 11 12
5	0	13 15 16
6	13	17

Balance delay: 0.177778

