

Quadratic Assignment Problem: a Simulated Annealing Algorithm



This Hypercard stack was prepared by:
Dennis Bricker,
Dept. of Industrial Engineering,
University of Iowa,
Iowa City, Iowa 52242
e-mail: dbricker@icaen.uiowa.edu

Example:

A floor layout
contains 12
rooms, each to
be assigned
a facility

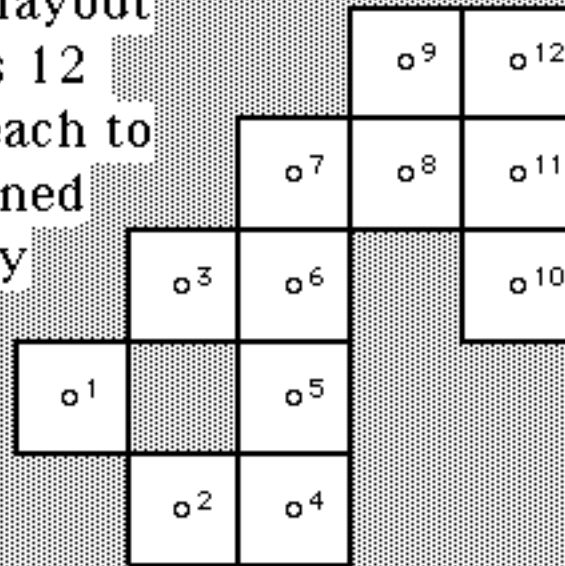

Define a binary decision variable for each combination of facility and location:

$$X_{ia} = \begin{cases} 1 & \text{if facility } i \text{ is located at "a"} \\ 0 & \text{otherwise} \end{cases}$$

Then $\sum_{i=1}^n X_{ia} = 1$ **for each location** $a=1, \dots, n$
(each location is to be assigned exactly one facility)

and $\sum_{a=1}^n X_{ia} = 1$ **for each facility** $i=1, \dots, n$
(each facility is to be assigned to a location)

Distance Matrix

D		to											
		1	2	3	4	5	6	7	8	9	10	11	12
1	0	2	2	3	2	3	4	5	6	5	6	7	
2	2	0	2	1	2	3	4	5	6	5	6	7	
3	2	2	0	3	2	1	2	3	4	3	4	5	
4	3	1	3	0	1	2	3	4	5	4	5	6	
5	2	2	2	1	0	1	2	3	4	3	4	5	
6	3	3	1	2	1	0	1	2	3	2	3	4	
7	4	4	2	3	2	1	0	1	2	3	2	3	
8	5	5	3	4	3	2	1	0	1	2	1	2	
9	6	6	4	5	4	3	2	1	0	3	2	1	
10	5	5	3	4	3	2	3	2	3	0	1	2	
11	6	6	4	5	4	3	2	1	2	1	0	1	
12	7	7	5	6	5	4	3	2	1	2	1	0	

f
r
o
m

*(These are the
"rectangular" distances
between centers of the
areas)*

Interfacility Flow Matrix

		to											
		A	B	C	D	E	F	G	H	I	J	K	L
f r o m	A			3						4	2		
	B									4			
	C	3					5	1			1	1	4
	D									1			
	E									1			3
	F			5							3		3
	G			1								3	
	H					1							
	I	4	4		1						4		1
	J			1			3				4		1
	K	2		1				3			1		
	L			4		3	3						

Density = 25.76%

If facility i is located at location "a", and facility j at "b", then the cost of the flow between this pair of facilities is assumed to be:

$$F_{ij} D_{ab}$$

Minimize

The optimization problem is to

$$\text{Minimize } \sum_{i=1}^n \sum_{j=1}^n \sum_{a=1}^n \sum_{b=1}^n F_{ij} D_{ab} X_{ia} X_{jb}$$

subject to

Note that the cost function is not linear, but QUADRATIC!

$$\sum_{i=1}^n X_{ia} = 1 \quad \text{for each location } a=1, \dots, n$$

(each location is to be assigned exactly one facility)

$$\sum_{a=1}^n X_{ia} = 1 \quad \text{for each facility } i=1, \dots, n$$

(each facility is to be assigned to a location)

$$X_{ia} \in \{ 1, 0 \} \quad \text{for each } i=1, \dots, n \text{ \& } a=1, \dots, n$$

A heuristic solution:

Facility Location

A	6
B	1
C	8
D	7
E	12
F	11
G	2
H	5
I	3
J	10
K	4
L	9

Cost: 160 sum of weighted distances

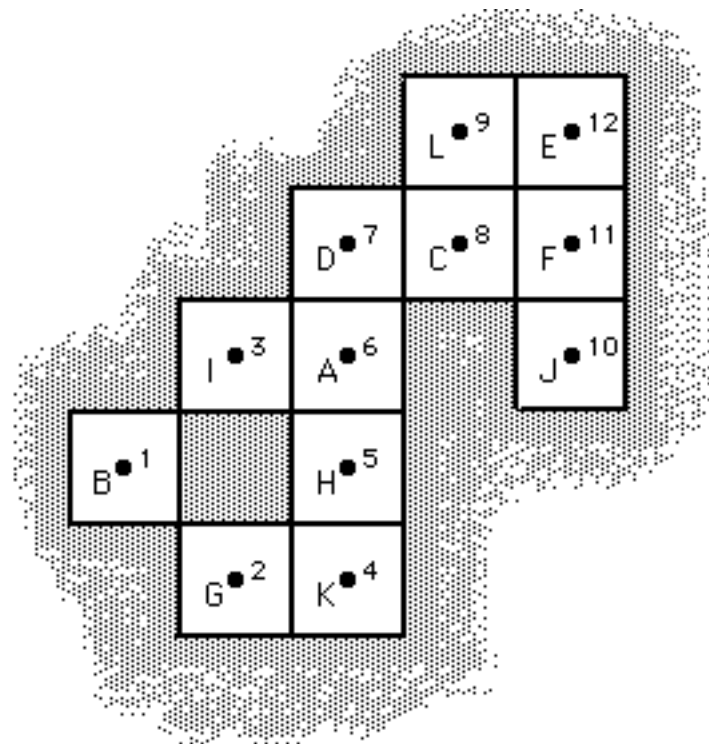

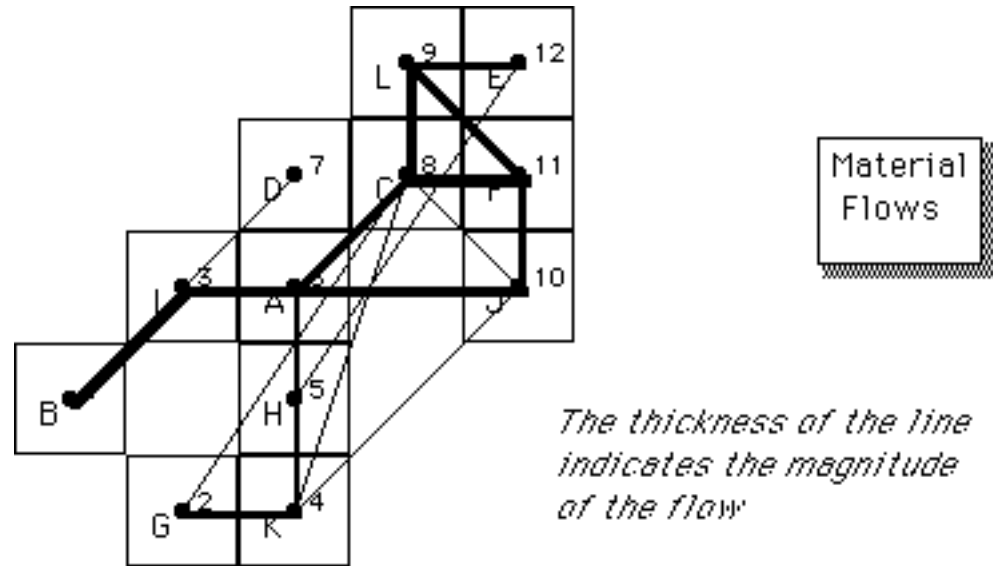

"Simulated Annealing"

- a heuristic search approach
- a move is made to any neighboring solution with equal or lower cost
- if the neighbor increases the cost by $\Delta > 0$, then the move is accepted with probability $P\{\text{accept } \Delta\} = e^{-\Delta/T}$ where T is the current "temperature" of the system
- the system is "cooled" according to some "cooling schedule"

We will consider the neighbors of a solution to be those which result from a "swap" of the locations of 2 facilities

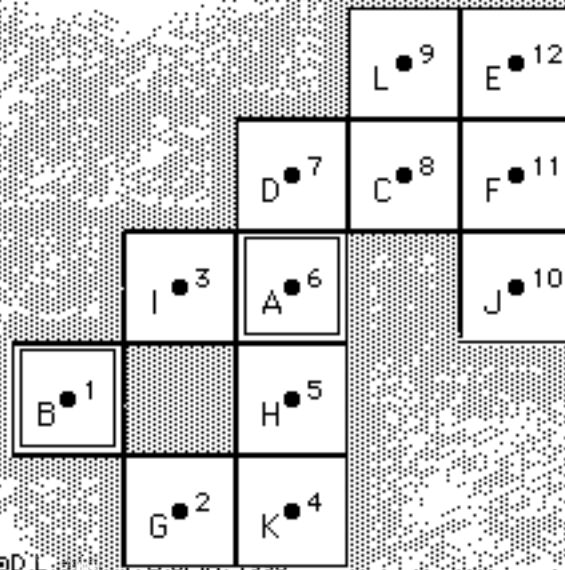

For example, swapping the locations of A & B gives a neighbor:

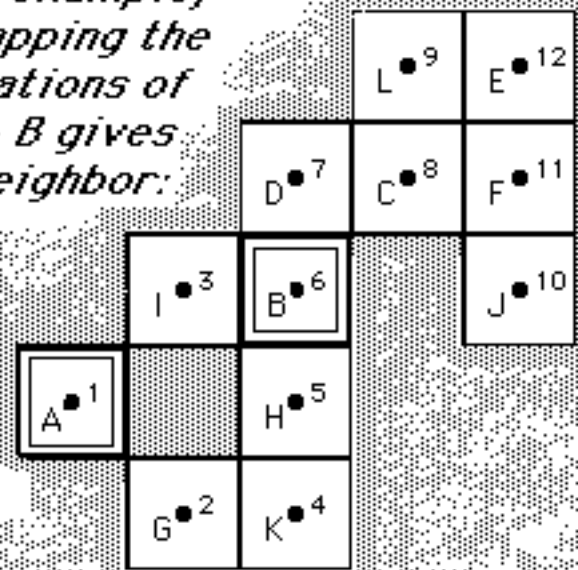

A typical simulated annealing result:

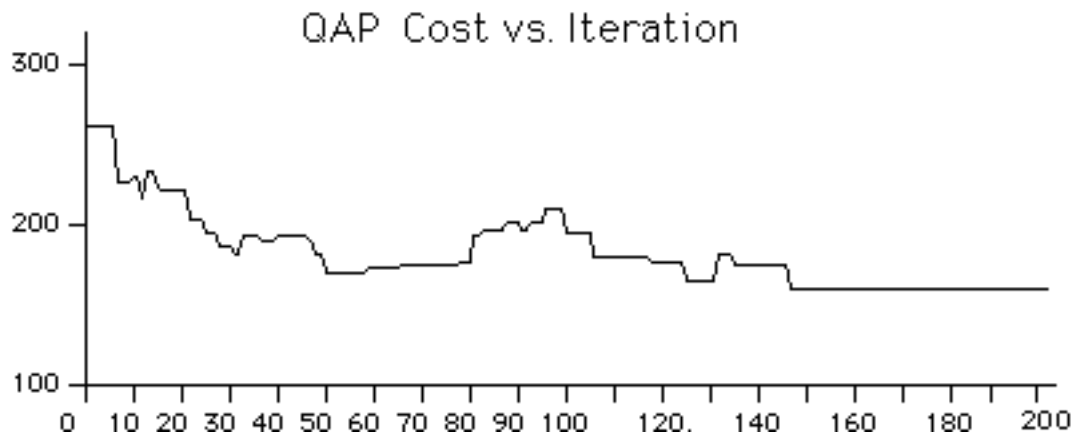

After each iteration, the temperature is reduced, according to a "cooling schedule"

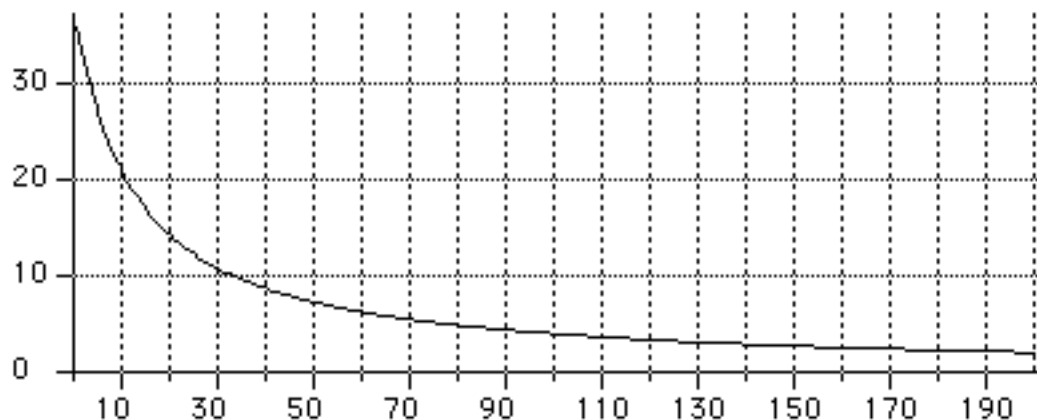

$$T_{i+1} = \frac{T_i}{1 + \beta T_i} \quad \text{where} \quad \beta = \frac{(T_0 - T_f)}{M T_0 T_f} \quad \& \quad \left\{ \begin{array}{l} T_0 = \text{initial temperature} \\ T_f = \text{final temperature} \\ M = \# \text{ of iterations} \end{array} \right.$$

As the system "cools", the probability of accepting an increase (of 10) decreases:

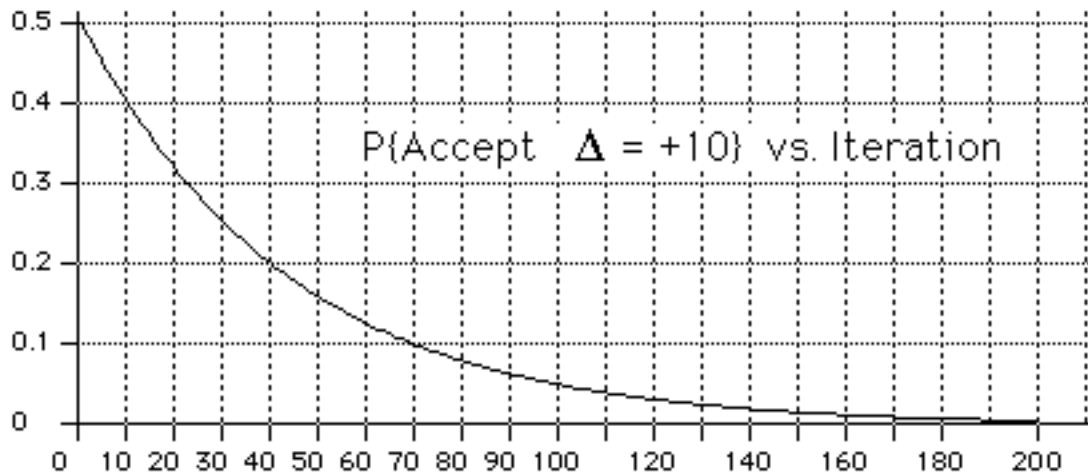

$$P\{\text{accept } \Delta\} = e^{-\Delta/T}$$

The first 15 iterations of a simulated annealing:

Iteration #	Temp	Z	Swap pair	Δ	P{accept}	Accept ?
1	14.42695	262	(1↔ 3)	44	0.0474	
2	13.96311	262	(1↔ 9)	12	0.4234	
3	13.52816	262	(1↔11)	0	1.0000	Y
4	13.11949	262	(2↔ 9)	18	0.2536	
5	12.73479	262	(3↔ 6)	28	0.1109	
6	12.37200	262	(3↔ 7)	-34	1.0000	Y ↓
7	12.02932	228	(3↔10)	12	0.3688	
8	11.70510	228	(3↔11)	84	0.0008	
9	11.39791	228	(3↔12)	2	0.8391	Y ↑
10	11.10642	230	(4↔ 9)	0	1.0000	Y
11	10.82948	230	(5↔ 8)	-12	1.0000	Y ↓
12	10.56600	218	(5↔12)	16	0.2200	Y ↑
13	10.31505	234	(6↔10)	20	0.1439	
14	10.07574	234	(6↔12)	-10	1.0000	Y ↓
15	9.84728	224	(7↔11)	-2	1.0000	Y ↓

*a swap which
results in an
increase is
accepted!*

QAP

Author Connolly, David T.

Title An improved annealing scheme for the QAP

Pub. European Journal of Operational Research, Volume 46 (1990),
pp. 93-100

Notes

Key Simulated annealing, heuristics

