

Lecture 5: DC & Transient Response

Outline

- Pass Transistors
- DC Response
- Logic Levels and Noise Margins
- Transient Response
- RC Delay Models
- Delay Estimation

Pass Transistors

- ❑ We have assumed source is grounded
- ❑ What if source > 0 ?
 - e.g. pass transistor passing V_{DD}
- ❑ $V_g = V_{DD}$
 - If $V_s > V_{DD} - V_t$, $V_{gs} < V_t$
 - Hence transistor would turn itself off
- ❑ nMOS pass transistors pull no higher than $V_{DD} - V_{tn}$
 - Called a degraded “1”
 - Approach degraded value slowly (low I_{ds})
- ❑ pMOS pass transistors pull no lower than V_{tp}
- ❑ Transmission gates are needed to pass both 0 and 1

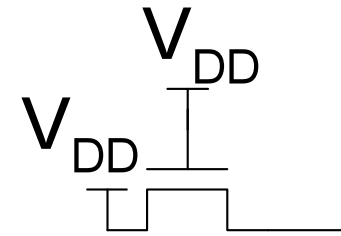

Pass Transistor Ckts

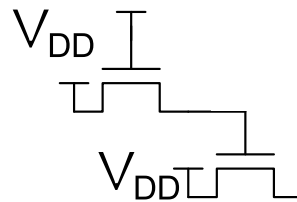
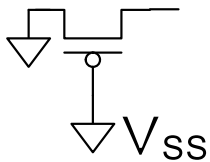
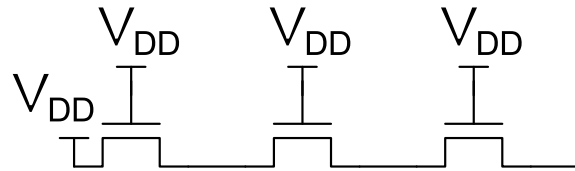
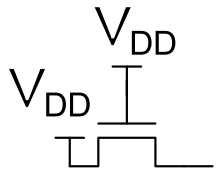

DC Response

□ DC Response: V_{out} vs. V_{in} for a gate

□ Ex: Inverter

– When $V_{in} = 0$ $\rightarrow V_{out} = V_{DD}$

– When $V_{in} = V_{DD}$ $\rightarrow V_{out} = 0$

– In between, V_{out} depends on transistor size and current

– By KCL, must settle such that

$$I_{dsn} = |I_{dsp}|$$

– We could solve equations

– But graphical solution gives more insight

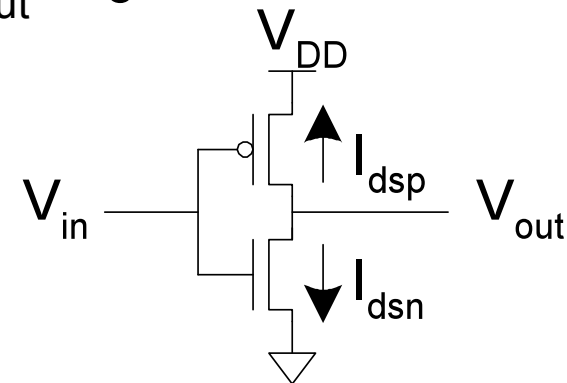

Transistor Operation

- ❑ Current depends on region of transistor behavior
- ❑ For what V_{in} and V_{out} are nMOS and pMOS in
 - Cutoff?
 - Linear?
 - Saturation?

nMOS Operation

Cutoff	Linear	Saturated
$V_{gsn} <$	$V_{gsn} >$	$V_{gsn} >$
	$V_{dsn} <$	$V_{dsn} >$

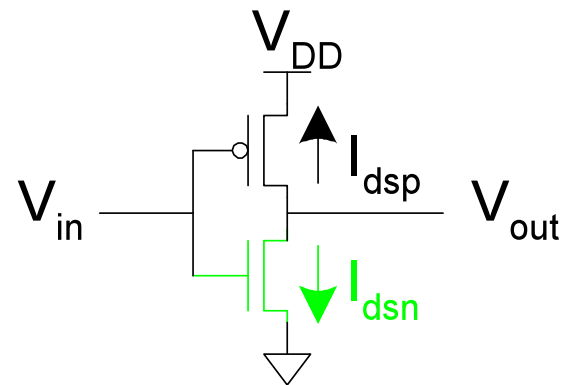

pMOS Operation

Cutoff	Linear	Saturated
$V_{gsp} > V_{tp}$ $V_{in} > V_{DD} + V_{tp}$	$V_{gsp} < V_{tp}$ $V_{in} < V_{DD} + V_{tp}$ $V_{dsp} > V_{gsp} - V_{tp}$ $V_{out} > V_{in} - V_{tp}$	$V_{gsp} < V_{tp}$ $V_{in} < V_{DD} + V_{tp}$ $V_{dsp} < V_{gsp} - V_{tp}$ $V_{out} < V_{in} - V_{tp}$

$$V_{gsp} = V_{in} - V_{DD}$$

$$V_{tp} < 0$$

$$V_{dsp} = V_{out} - V_{DD}$$

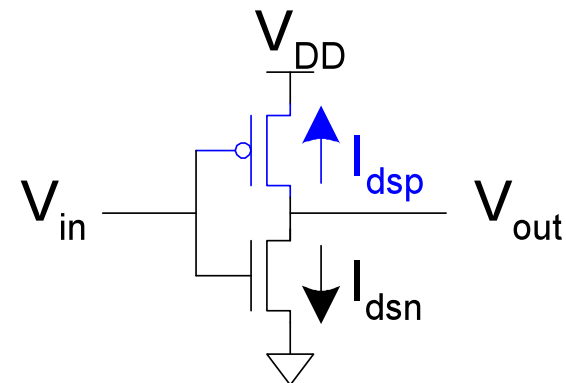

I-V Characteristics

- Make pMOS is wider than nMOS such that $\beta_n = \beta_p$

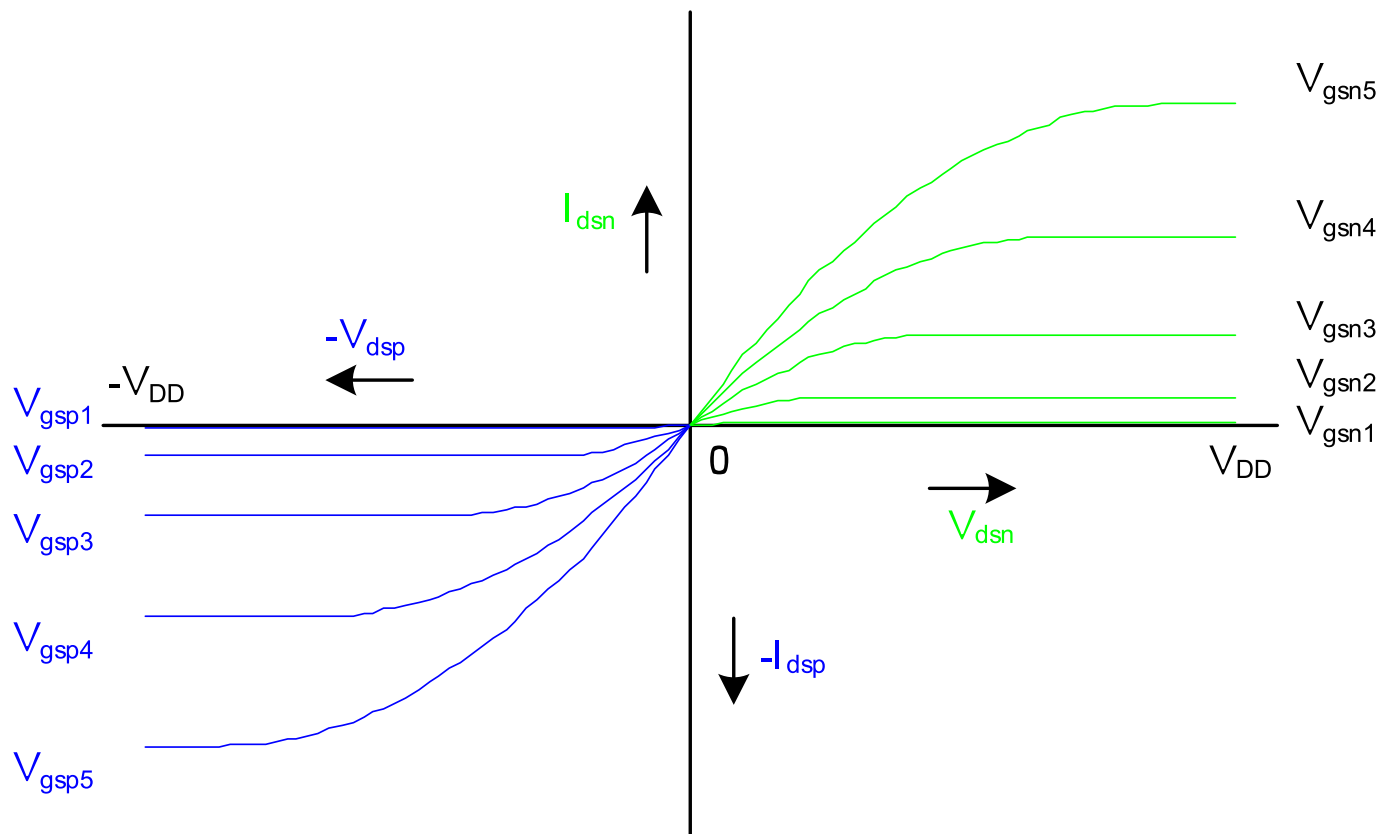

Current vs. V_{out} , V_{in}

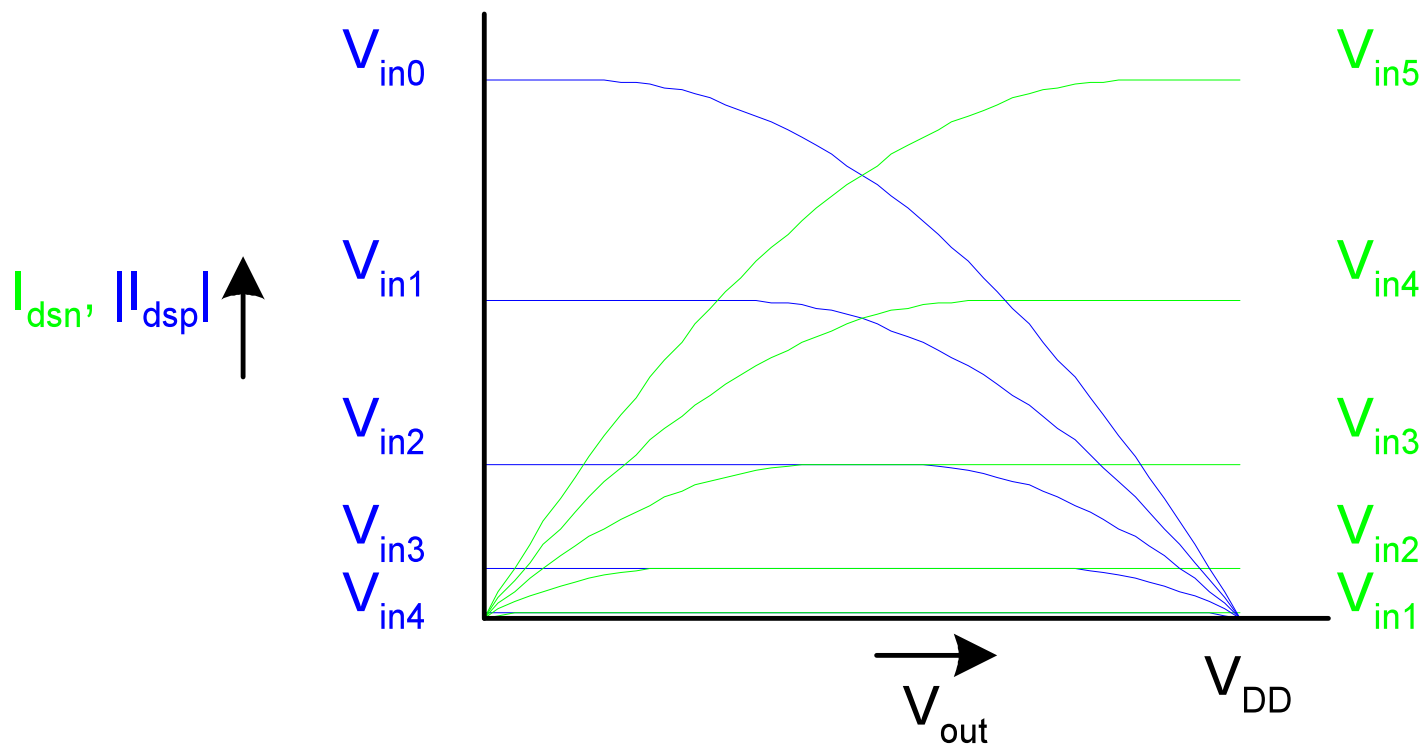

Load Line Analysis

- For a given V_{in} :
 - Plot I_{dsn} , I_{dsp} vs. V_{out}
 - V_{out} must be where |currents| are equal in

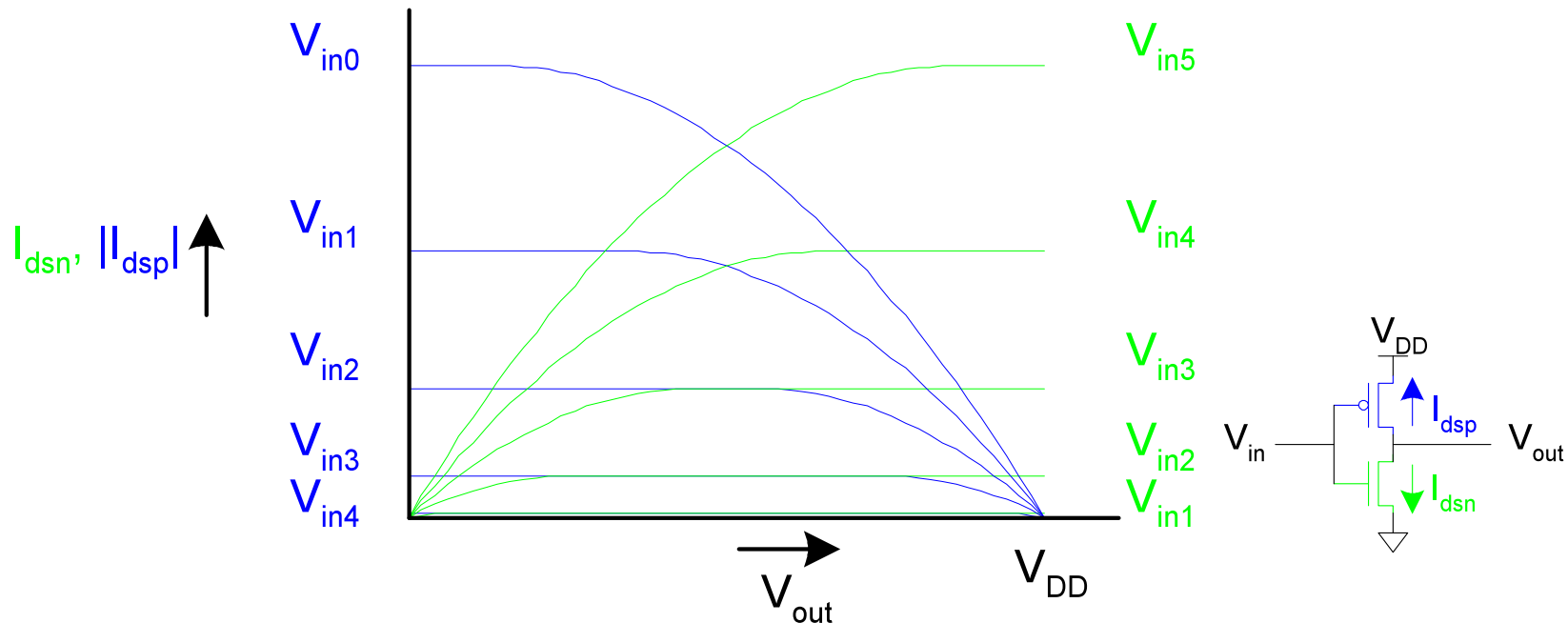

Load Line Analysis

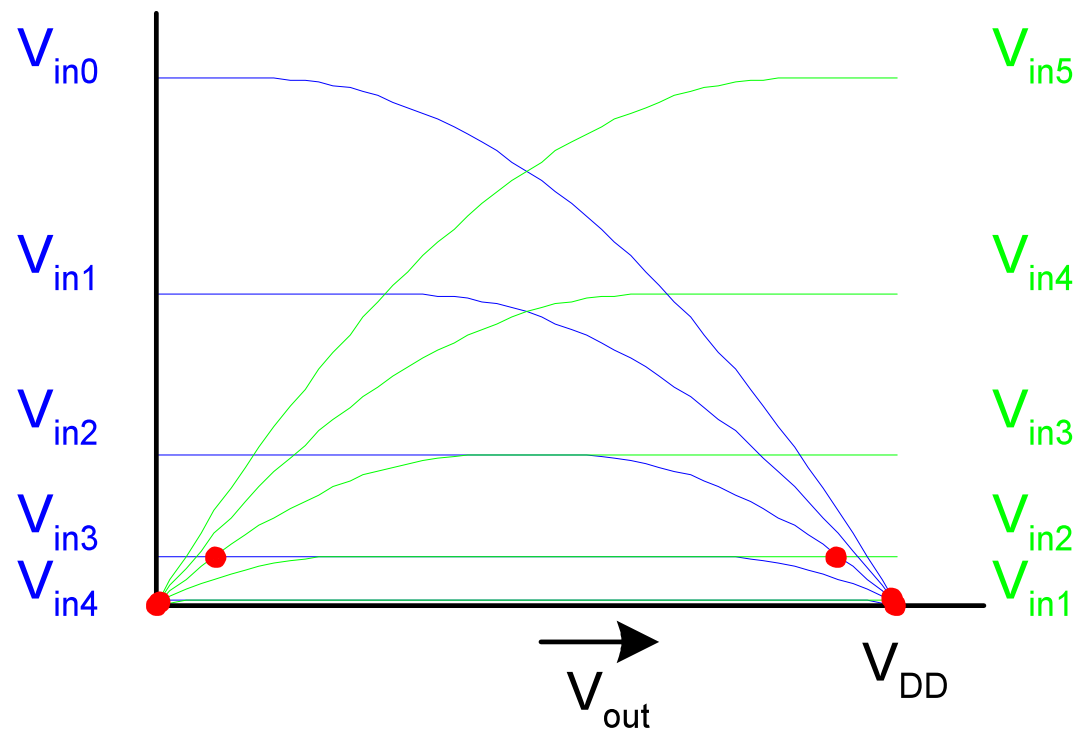

DC Transfer Curve

- Transcribe points onto V_{in} vs. V_{out} plot

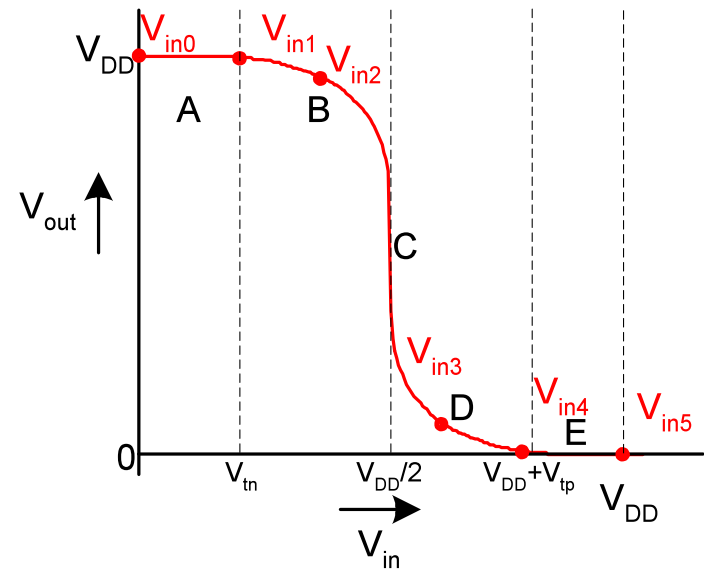
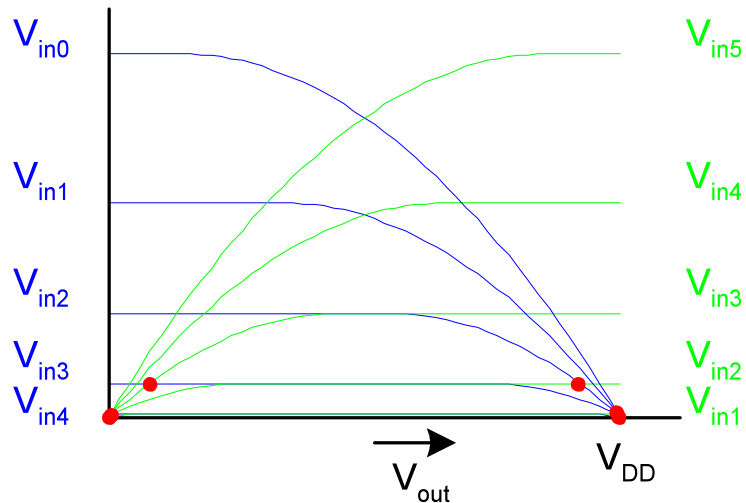

Operating Regions

- Revisit transistor operating regions

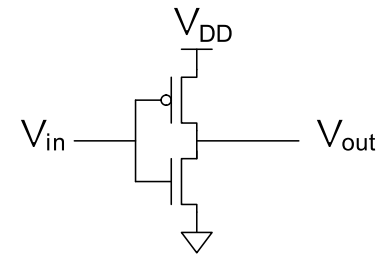

Region	nMOS	pMOS
A		
B		
C		
D		
E		

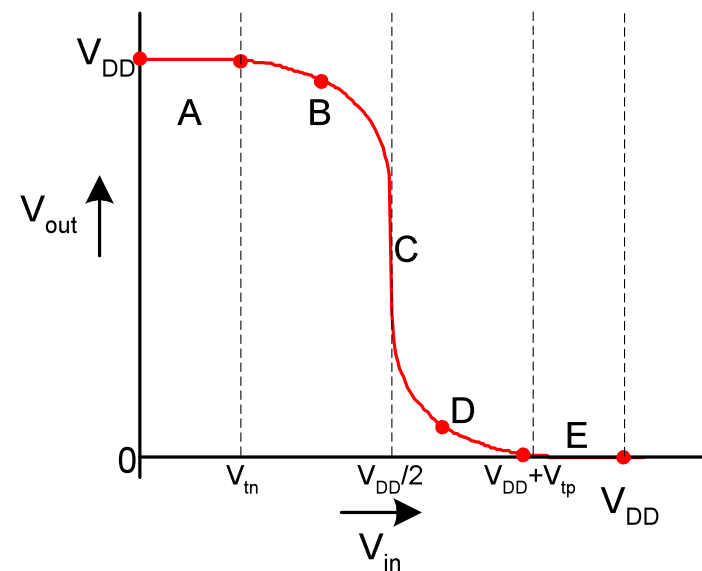

Beta Ratio

- ❑ If $\beta_p / \beta_n \neq 1$, switching point will move from $V_{DD}/2$
- ❑ Called *skewed gate*
- ❑ Other gates: collapse into equivalent inverter

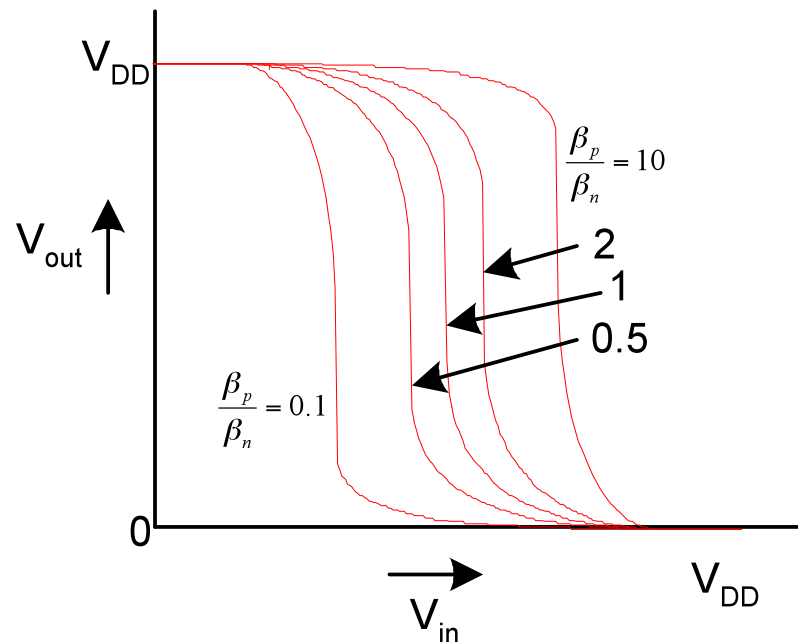

Noise Margins

- How much noise can a gate input see before it does not recognize the input?

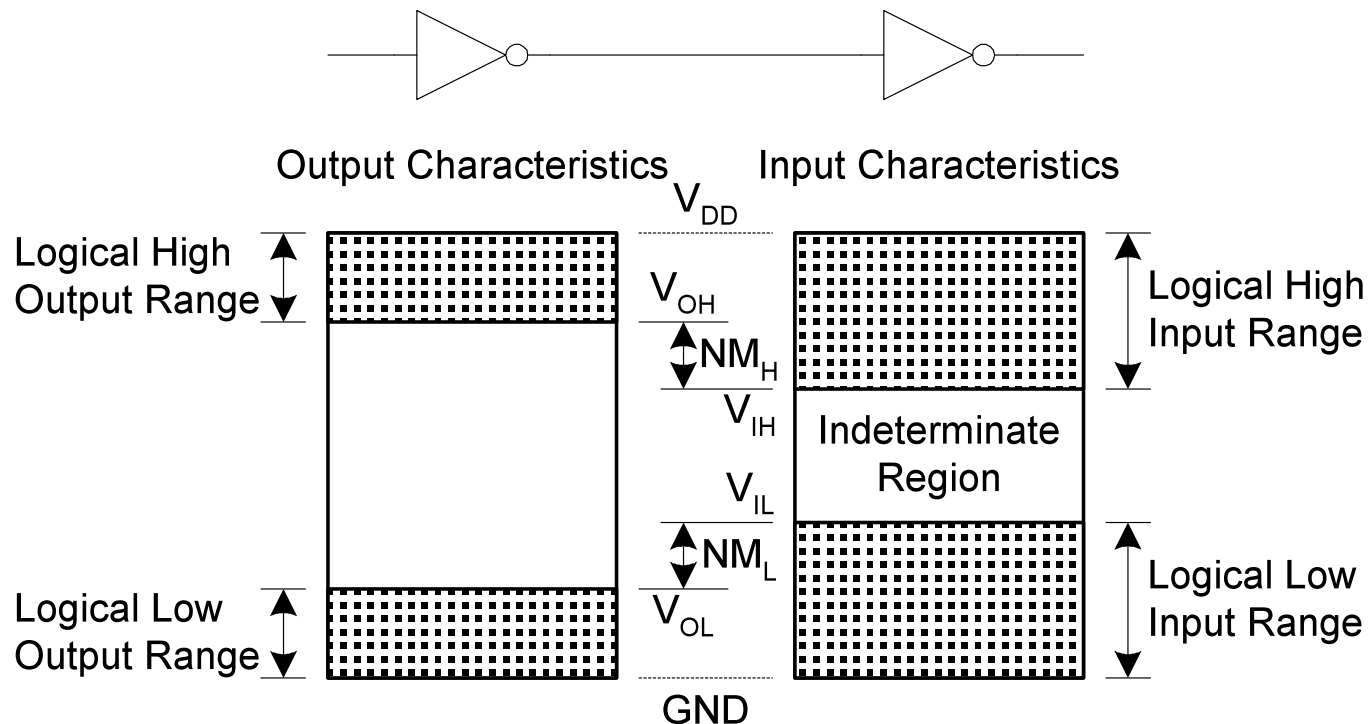

Logic Levels

- ❑ To maximize noise margins, select logic levels at
 - unity gain point of DC transfer characteristic

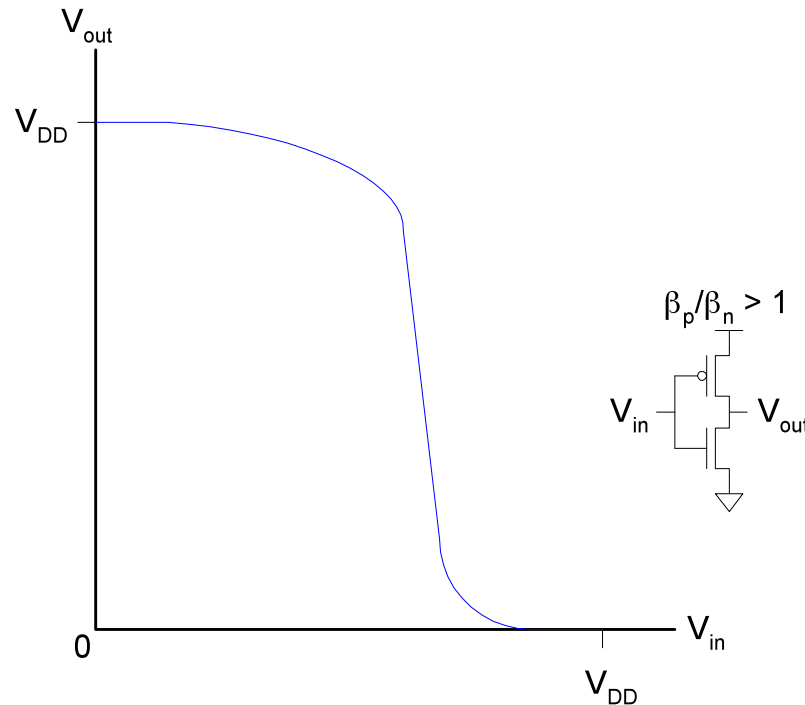

Transient Response

- ❑ *DC analysis* tells us V_{out} if V_{in} is constant
- ❑ *Transient analysis* tells us $V_{out}(t)$ if $V_{in}(t)$ changes
 - Requires solving differential equations
- ❑ Input is usually considered to be a step or ramp
 - From 0 to V_{DD} or vice versa

Inverter Step Response

- Ex: find step response of inverter driving load cap

$$V_{in}(t) =$$

$$V_{out}(t < t_0) =$$

$$\frac{dV_{out}(t)}{dt} =$$

$$I_{dsn}(t) = \left\{ \begin{array}{l} \\ \\ \end{array} \right.$$

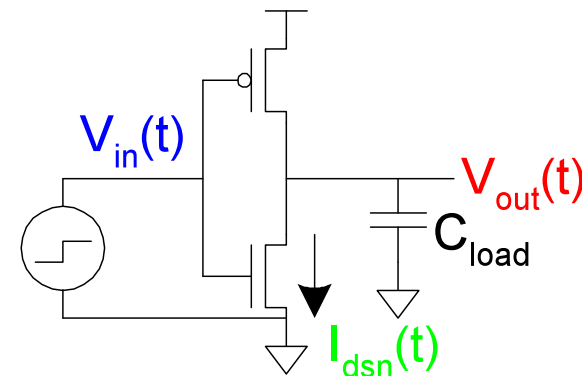

$$t \leq t_0$$

$$V_{out} > V_{DD} - V_t$$

$$V_{out} < V_{DD} - V_t$$

Delay Definitions

- ❑ t_{pdr} : *rising propagation delay*
 - From input to rising output crossing $V_{DD}/2$
- ❑ t_{pdf} : *falling propagation delay*
 - From input to falling output crossing $V_{DD}/2$
- ❑ t_{pd} : *average propagation delay*
 - $t_{pd} = (t_{pdr} + t_{pdf})/2$
- ❑ t_r : *rise time*
 - From output crossing $0.2 V_{DD}$ to $0.8 V_{DD}$
- ❑ t_f : *fall time*
 - From output crossing $0.8 V_{DD}$ to $0.2 V_{DD}$

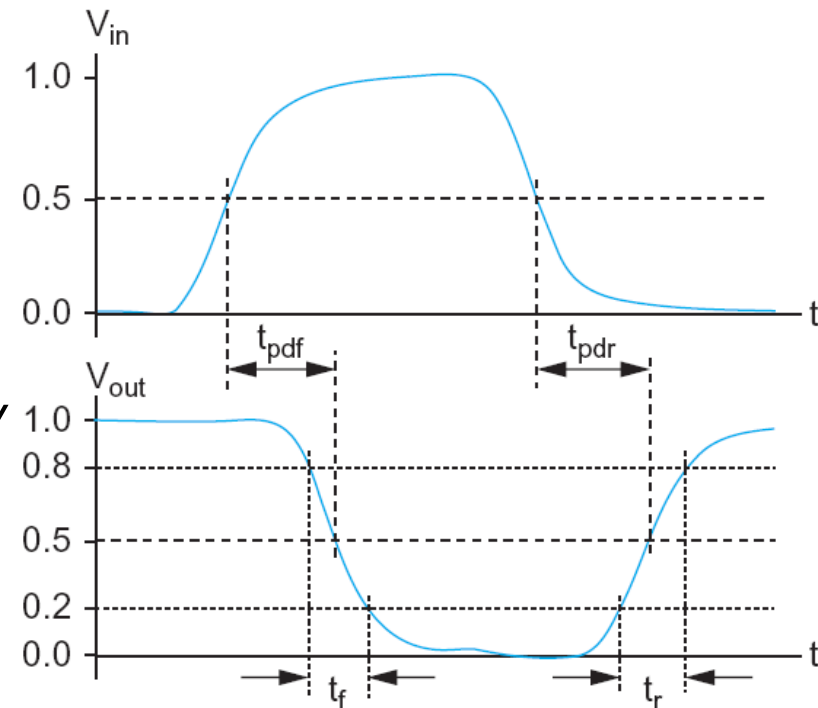

Delay Definitions

- t_{cdr} : *rising contamination delay*
 - From input to rising output crossing $V_{DD}/2$
- t_{cdf} : *falling contamination delay*
 - From input to falling output crossing $V_{DD}/2$
- t_{cd} : *average contamination delay*
 - $t_{pd} = (t_{cdr} + t_{cdf})/2$

Simulated Inverter Delay

- ❑ Solving differential equations by hand is too hard
- ❑ SPICE simulator solves the equations numerically
 - Uses more accurate I-V models too!
- ❑ But simulations take time to write, may hide insight

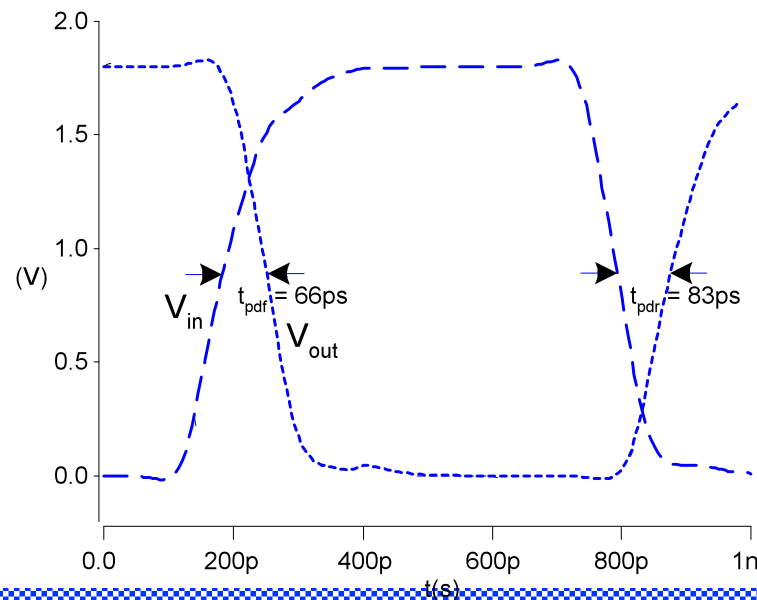

Delay Estimation

- ❑ We would like to be able to easily estimate delay
 - Not as accurate as simulation
 - But easier to ask “What if?”
- ❑ The step response usually looks like a 1st order RC response with a decaying exponential.
- ❑ Use RC delay models to estimate delay
 - C = total capacitance on output node
 - Use *effective resistance* R
 - So that $t_{pd} = RC$
- ❑ Characterize transistors by finding their effective R
 - Depends on average current as gate switches

Effective Resistance

- ❑ Shockley models have limited value
 - Not accurate enough for modern transistors
 - Too complicated for much hand analysis
- ❑ Simplification: treat transistor as resistor
 - Replace $I_{ds}(V_{ds}, V_{gs})$ with effective resistance R
 - $I_{ds} = V_{ds}/R$
 - R averaged across switching of digital gate
- ❑ Too inaccurate to predict current at any given time
 - But good enough to predict RC delay

RC Delay Model

- ❑ Use equivalent circuits for MOS transistors
 - Ideal switch + capacitance and ON resistance
 - Unit nMOS has resistance R , capacitance C
 - Unit pMOS has resistance $2R$, capacitance C
- ❑ Capacitance proportional to width
- ❑ Resistance inversely proportional to width

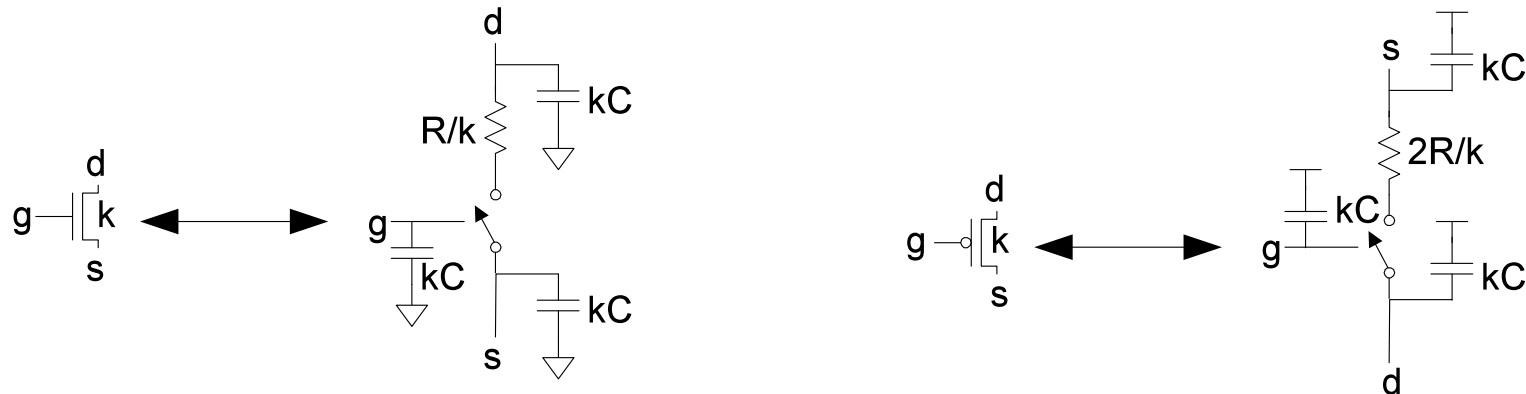

RC Values

- ❑ Capacitance
 - $C = C_g = C_s = C_d = 2 \text{ fF}/\mu\text{m}$ of gate width in $0.6 \mu\text{m}$
 - Gradually decline to $1 \text{ fF}/\mu\text{m}$ in nanometer techs.
- ❑ Resistance
 - $R \approx 6 \text{ K}\Omega \cdot \mu\text{m}$ in $0.6 \mu\text{m}$ process
 - Improves with shorter channel lengths
- ❑ Unit transistors
 - May refer to minimum contacted device ($4/2 \lambda$)
 - Or maybe $1 \mu\text{m}$ wide device
 - Doesn't matter as long as you are consistent

Inverter Delay Estimate

- Estimate the delay of a fanout-of-1 inverter

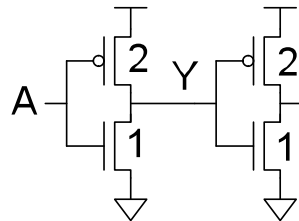

$$d = 6RC$$

Delay Model Comparison

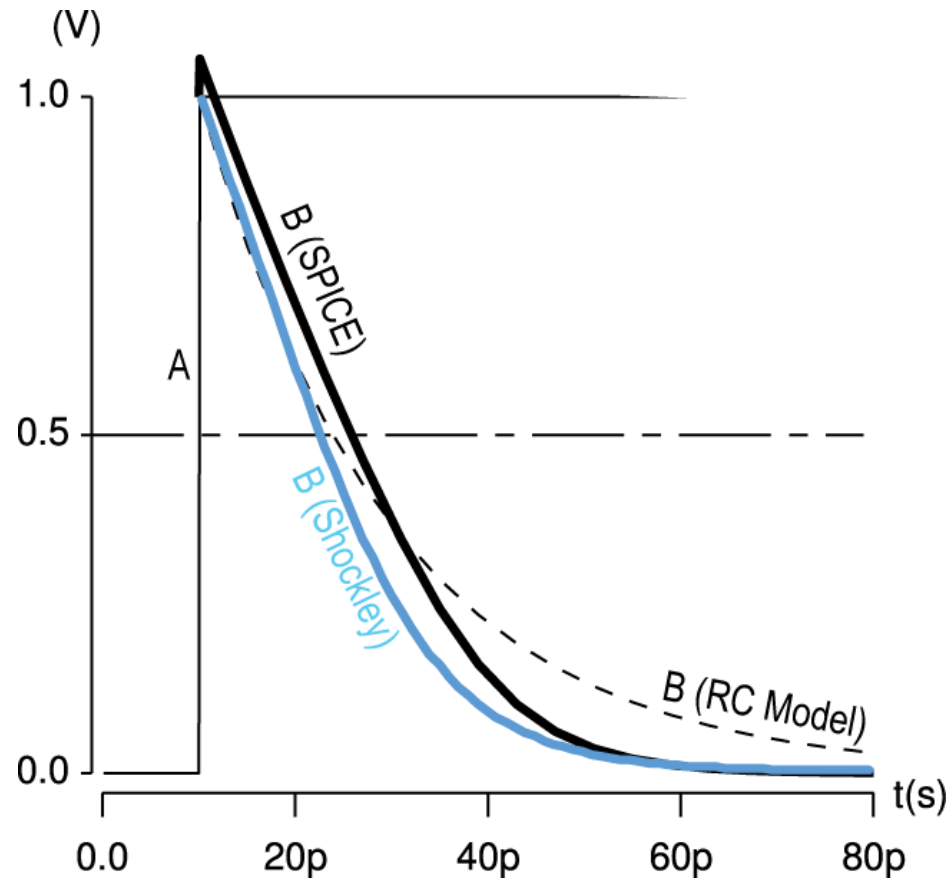

Example: 3-input NAND

- Sketch a 3-input NAND with transistor widths chosen to achieve effective rise and fall resistances equal to a unit inverter (R).

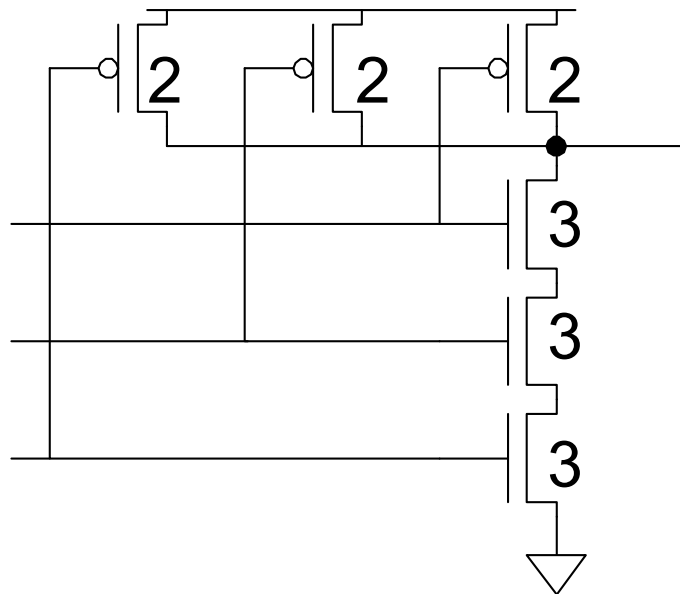

3-input NAND Caps

- Annotate the 3-input NAND gate with gate and diffusion capacitance.

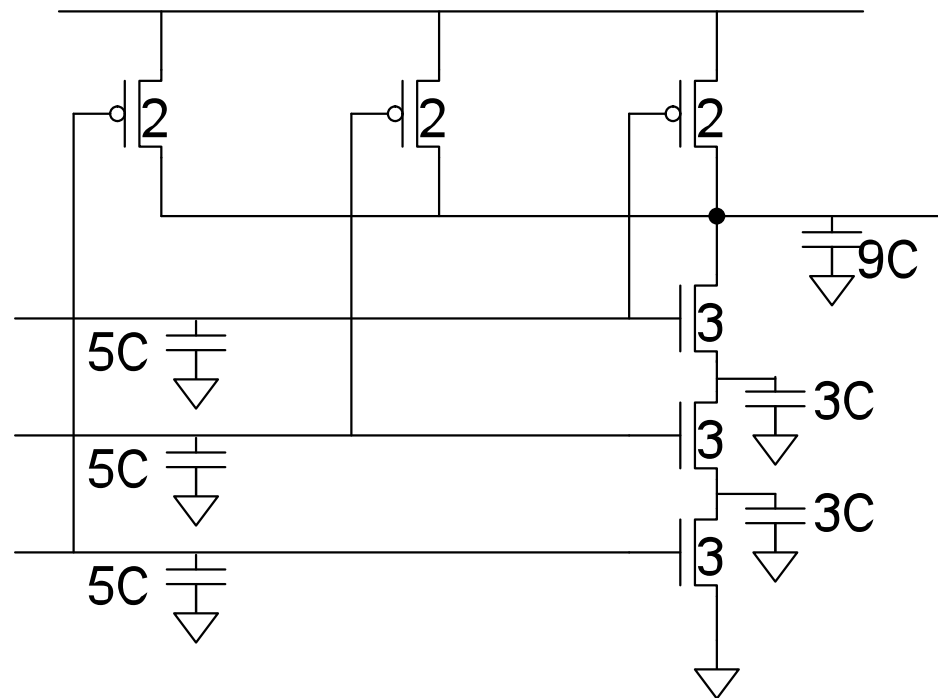

Elmore Delay

- ❑ ON transistors look like resistors
- ❑ Pullup or pulldown network modeled as *RC ladder*
- ❑ Elmore delay of RC ladder

$$t_{pd} \approx \sum_{\text{nodes } i} R_{i\text{-to-source}} C_i$$

$$= R_1 C_1 + (R_1 + R_2) C_2 + \dots + (R_1 + R_2 + \dots + R_N) C_N$$

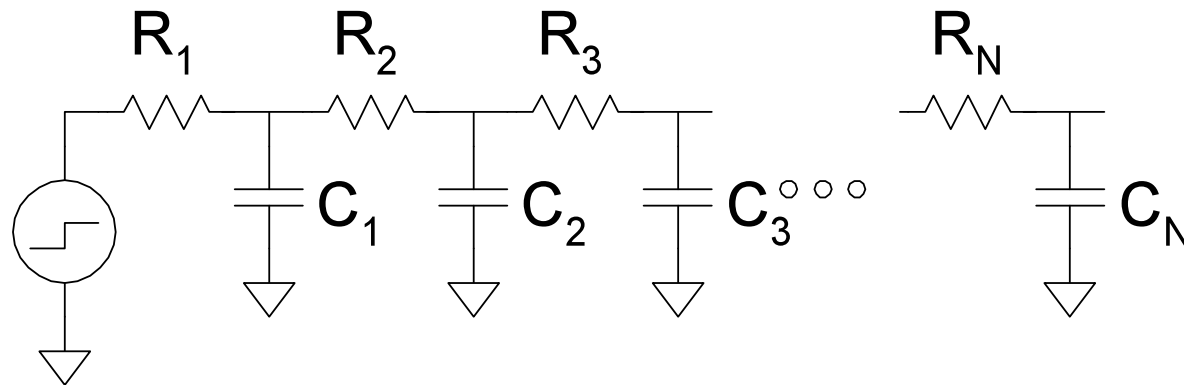

Example: 3-input NAND

- Estimate worst-case rising and falling delay of 3-input NAND driving h identical gates.

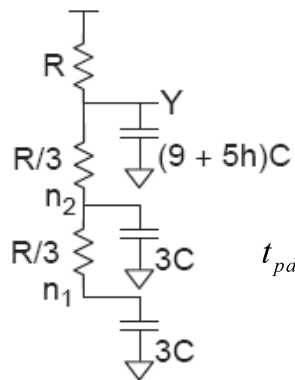
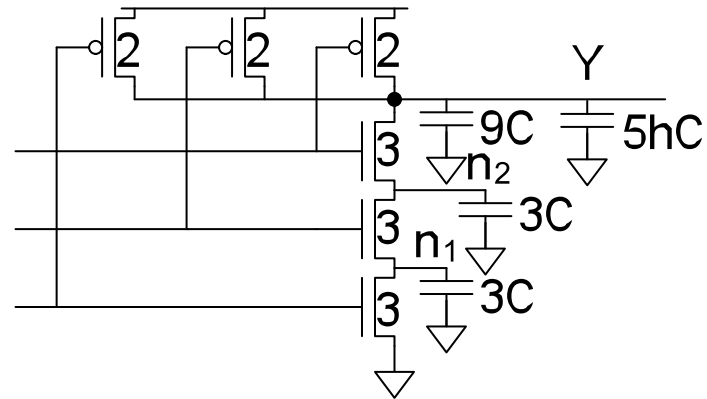
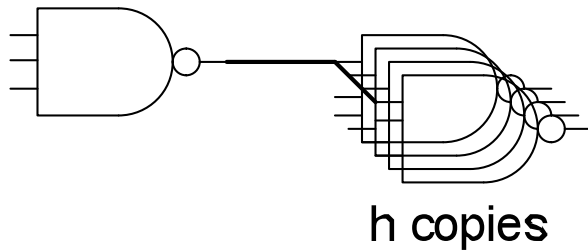

$$t_{pdr} = (9 + 5h)RC$$

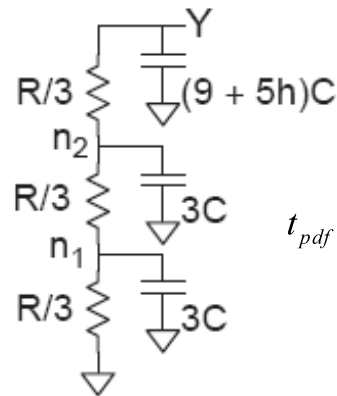

$$t_{pdf} = (3C)\left(\frac{R}{3}\right) + (3C)\left(\frac{R}{3} + \frac{R}{3}\right) + [(9 + 5h)C]\left(\frac{R}{3} + \frac{R}{3} + \frac{R}{3}\right)$$

$$= (11 + 5h)RC$$

Delay Components

- Delay has two parts
 - *Parasitic delay*
 - 9 or 11 RC
 - Independent of load
 - *Effort delay*
 - 5h RC
 - Proportional to load capacitance

Contamination Delay

- ❑ Best-case (contamination) delay can be substantially less than propagation delay.
- ❑ Ex: If all three inputs fall simultaneously

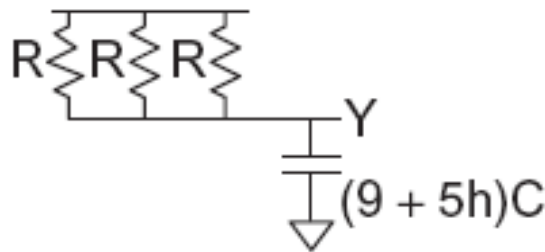
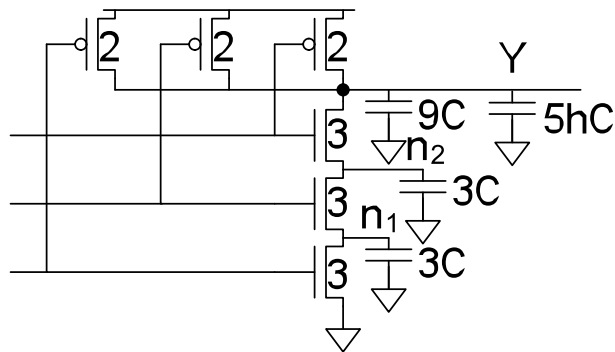

$$t_{cdr} = [(9 + 5h)C] \left(\frac{R}{3} \right) = \left(3 + \frac{5}{3}h \right) RC$$

Diffusion Capacitance

- ❑ We assumed contacted diffusion on every s / d.
- ❑ Good layout minimizes diffusion area
- ❑ Ex: NAND3 layout shares one diffusion contact
 - Reduces output capacitance by $2C$
 - Merged uncontacted diffusion might help too

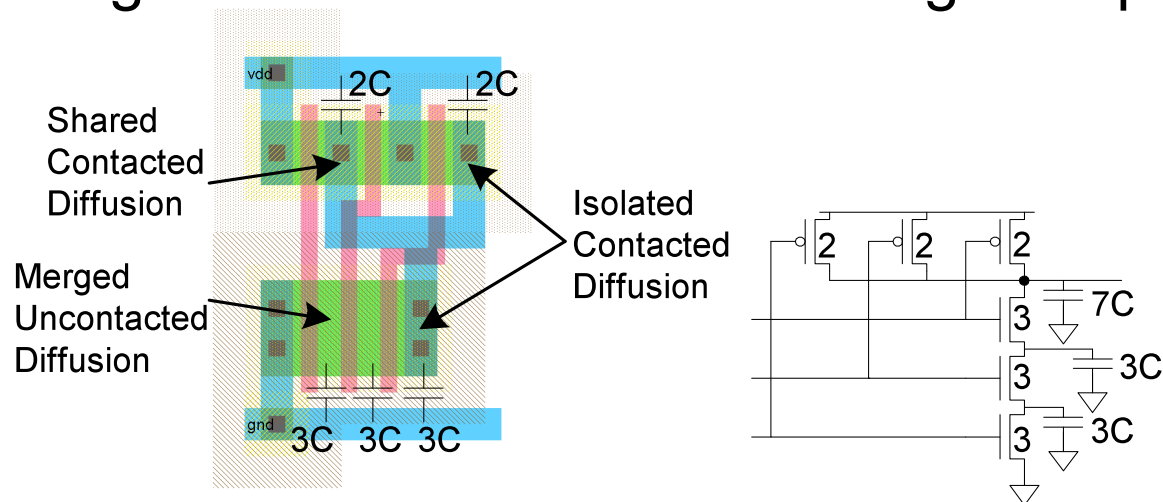

Layout Comparison

□ Which layout is better?

