



This is a digital copy of a book that was preserved for generations on library shelves before it was carefully scanned by Google as part of a project to make the world's books discoverable online.

It has survived long enough for the copyright to expire and the book to enter the public domain. A public domain book is one that was never subject to copyright or whose legal copyright term has expired. Whether a book is in the public domain may vary country to country. Public domain books are our gateways to the past, representing a wealth of history, culture and knowledge that's often difficult to discover.

Marks, notations and other marginalia present in the original volume will appear in this file - a reminder of this book's long journey from the publisher to a library and finally to you.

### **Usage guidelines**

Google is proud to partner with libraries to digitize public domain materials and make them widely accessible. Public domain books belong to the public and we are merely their custodians. Nevertheless, this work is expensive, so in order to keep providing this resource, we have taken steps to prevent abuse by commercial parties, including placing technical restrictions on automated querying.

We also ask that you:

- + *Make non-commercial use of the files* We designed Google Book Search for use by individuals, and we request that you use these files for personal, non-commercial purposes.
- + *Refrain from automated querying* Do not send automated queries of any sort to Google's system: If you are conducting research on machine translation, optical character recognition or other areas where access to a large amount of text is helpful, please contact us. We encourage the use of public domain materials for these purposes and may be able to help.
- + *Maintain attribution* The Google "watermark" you see on each file is essential for informing people about this project and helping them find additional materials through Google Book Search. Please do not remove it.
- + *Keep it legal* Whatever your use, remember that you are responsible for ensuring that what you are doing is legal. Do not assume that just because we believe a book is in the public domain for users in the United States, that the work is also in the public domain for users in other countries. Whether a book is still in copyright varies from country to country, and we can't offer guidance on whether any specific use of any specific book is allowed. Please do not assume that a book's appearance in Google Book Search means it can be used in any manner anywhere in the world. Copyright infringement liability can be quite severe.

### **About Google Book Search**

Google's mission is to organize the world's information and to make it universally accessible and useful. Google Book Search helps readers discover the world's books while helping authors and publishers reach new audiences. You can search through the full text of this book on the web at <http://books.google.com/>

NYPL RESEARCH LIBRARIES



3 3433 06633400 8

---

R D has other id



f

613

3-1-12 B













20  
72  
11

THE NEW YORK  
PUBLIC LIBRARY  
ASTOR, LENOX  
TILDEN FOUNDATIONS



EAST RIVER BARGE.—See page 371.

# A TREATISE

OR

# CIVIL ENGINEERING

BY

D. H. MAHAN, LL.D.,

LATE PROFESSOR OF CIVIL ENGINEERING AT WEST POINT, N. Y.

REVISED AND EDITED, WITH ADDITIONS AND NEW PLATES,

By DE VOLSON WOOD,

PROFESSOR OF ENGINEERING IN STEVENS INSTITUTE OF TECHNOLOGY (FORMERLY PROFESSOR OF CIVIL ENGINEERING IN THE UNIVERSITY OF MICHIGAN); MEMBER OF THE AMERICAN SOCIETY OF MECHANICAL ENGINEERS AND OF OTHER SOCIETIES; AUTHOR OF A TREATISE ON THE RESISTANCE OF MATERIALS; TREATISE ON BRIDGES AND ROOFS; MECHANICS; THERMODYNAMICS AND OTHER WORKS, ETC.

NEW YORK:  
JOHN WILEY & SON,

53 E. TENTH ST.

1890.

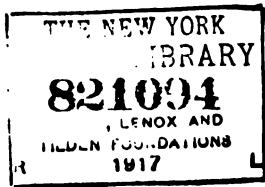

Entered, according to Act of Congress, in the year 1908, by  
JOHN WILEY,  
In the Office of the Librarian of Congress, at Washington, D. C.

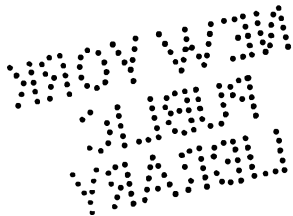

## PREFACE.

---

THE works of the late Professor Mahan are too well and too favorably known to need special comment from the present Editor.

The first edition of his work on Civil Engineering appeared when engineering as a learned profession was scarcely recognized in this country, and when but a very limited amount of instruction upon the science which pertains to it was given in our schools. Descriptions of processes and of works executed were the essential means of giving the information which was needed by the engineer. This determined the essential characteristic of his work, which is *descriptive*.

More recently, numerous schools have been established, which are intended to give thorough instruction in the science of engineering, and in which the courses of instruction are largely filled with *mathematical analysis*. But analysis alone, however important, can never take the place of descriptive matter. Every successful structure serves as a guide in the construction of all future similar works. Thus the experience of one may become the wisdom of many.

Before his untimely death, Professor Mahan had prepared

Mrs. Nelson Smith - 8 Aug 1917

a thorough revision of this work, and about one-third of it had passed through the press when the present Editor took charge of it.

I have endeavored to do full justice to the original author by preserving the essential character of the work, and retaining nearly all the matter which he had prepared; still, I have omitted a few paragraphs which were deemed non-essential, and condensed others. I have also added considerable new matter, which is scattered throughout that portion of the work which I have had in charge. I trust that my labors have added to the value of the work.

**D<sup>r</sup> V. W**

**HOBOKEN Aug., 1878.**

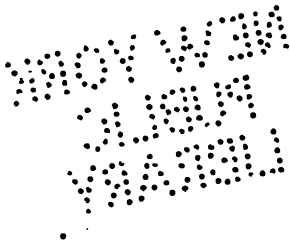

# CONTENTS.

## CHAPTER I.

### GENERAL PROPERTIES OF BUILDING MATERIALS.

ARTICLE.	PAGE.
1-2. Introductory Remark.....	3
I. STONE.	
3-16. Silicious Stones.....	4
17-20. Argillaceous Stones.....	8
21-29. Calcareous Stones.....	9
30-36. Gypsum—Durability of Stone.....	13
37-38. Effects of Heat—Hardness of Stone.....	15
II. LIME.	
38-41. Classification.....	18
42-49. Hydraulic Limes and Cements.....	19
50-55. Physical Characteristics of Hydraulic Limestones.....	23
56-60. Calcination of Limestone.....	25
III. LIME-KILNS.	
61-76. Descriptions of Lime-kilns.....	27
77. Calcination of the Stone.....	36
78-95. Reducing Calcined Stone to Powder.....	37
96-103. Artificial Hydraulic Limes and Cements.....	41
104-114. Puzzolanas.....	43
IV. MORTAR.	
115-120. Classification—Qualities.....	46
121-127. Sand, Properties of.....	47
128-134. Hydraulic Mortar.....	48
135-138. Mortars exposed to Weather.....	50
139-142. Manipulations of Mortar—Machines for.....	51
143-150. Setting and Durability of Mortars.....	57
151-152. Theory of the Hardening of Mortars.....	58
V. CONCRETE BETON.	
153-157. Concrete—Manufacture and Use.....	59
158-166. Béton—Manufacture and Use.....	60



ARTICLE.	PAGE
167. Ransome's Artificial Stone.....	63
168-182. Béton Aggloméré.....	64
183-186. Adherence of Mortar.....	73
<b>VI. MASTICS.</b>	
187-198. Composition of—Bituminous Mastic.....	74
<b>VII. BRICKS.</b>	
99-311. Common Brick—Fire-Brick—Tile.....	77
<b>VIII. WOOD.</b>	
212-214. Timber—Parts of the Trunk of a Tree.....	79
215-217. Felling Trees—Time and Treatment.....	80
218-225. Methods of Seasoning Timber.....	81
226. Wet and Dry Rot.....	83
227-239. Preservation of Timber.....	83
240-242. Durability of Timber.....	86
243-248. Forest Trees of the United States which are used for Timber.....	86
<b>IX. METALS.</b>	
249-263. Cast Iron, Qualities of.....	89
264-277. Wrought Iron, Qualities of.....	92
278-289. Durability of Iron.....	94
290-298. Preservatives of Iron.....	95
299. Corrugated Iron.....	97
300. Steel.....	98
301. Copper.....	98
302. Zinc.....	99
303. Tin.....	99
304. Lead.....	99
<b>X. PAINT AND VARNISHES.</b>	
305-308. Composition and Uses of Paints.....	100
309-313. Composition and Uses of Varnishes.....	100
314. Zoöfagous Paint.....	103
315. Methods of Preserving Exposed Surfaces of Stone.....	103

## CHAPTER II.

### EXPERIMENTAL RESEARCHES ON THE STRENGTH OF MATERIALS.

316-326. Physical Properties of Bodies.....	106
327-335. Strength of Stone.....	109
336-342. Strength of Mortars and Cements.....	115
343-347. Strength of Timber.....	119
348-365. Strength of Cast Iron.....	131
366-367. Effect of Impact upon Cast-Iron Bars.....	144
368-374. Strength of Wrought Iron.....	147

ARTICLE.	PAGE.
375. Strength of Steel.....	163
376. Strength of Copper.....	166
377. Effects of Temperature on the Tensile Strength.....	167
378. Strength of Cast Tin, of Cast Lead, hard Gun-metal.....	167
379. Coefficients of Linear Expansion due to Heat.....	167
380. Adhesion of Iron Spikes to Timber.....	170

## CHAPTER III.

## MASONRY.

I. Classification Masonry.....	174
II. Cut-stone Masonry.....	174
III. Rubble-stone Masonry.....	183
IV. Brick Masonry.....	183

## V. FOUNDATIONS OF STRUCTURES ON LAND.

417-418. Definition—Importance.....	190
420. Classification of Soils.....	190
421-423. Foundations on Rock.....	191
424-425. Foundations on Sand.....	192
426-430. Foundations on Compressible Soils.....	192
431-440. Foundations on Piles.....	196
441-443. Sand for Bed of Foundation.....	203

## VI. FOUNDATIONS OF STRUCTURES IN WATER.

444-449. Coffor-Work—Caisson.....	208
452-455. Foundations on Heavy Blocks of Loose Stone.....	217
456. Pneumatic Processes.....	220
457-458. Pneumatic Piles.....	220
459. Pneumatic Caissons. ST. LOUIS BRIDGE.....	229
EAST RIVER BRIDGE.....	234

## VII. CONSTRUCTION OF MASONRY.

461-466. Foundation Courses—Construction of.....	236
467. Classification of Structures of Masonry.....	238
468. Walls of Enclosures.....	238
469. Walls for Vertical Supports.....	239
470. Areas.....	239
471-479. Retaining Walls. FORM AND DIMENSIONS.....	239
480-490. Modes of Strengthening Retaining Walls—Counterforts—Relieving Arches.....	244
491-492. Lintel—Plate-Bande.....	247
493-503. Arches—Definitions—Annular Arches—Dome.....	248
504-513. Details of the Masonry of Arches.....	252
514-516. Angle of Rupture.....	257
517-519. Remarks upon the Strengthening of Abutments.....	258
520. Precautions against Settling.....	258
521-523. Pointing of Masonry.....	259
524-526. Repairs of Masonry.....	260
527. Effects of Temperature on Masonry.....	261

## CHAPTER IV.

## FRAMING.

528-539.	General Principles.....	263
540.	Solid-built Beams.....	265
541-547.	Joints of Different Kinds.....	267
548.	Open-built Beams.....	271
549-550.	Framing for Intermediate Supports.....	272
551.	Experiments on the Strength of Frames.....	274
553-553.	Wooden Arches.....	277

## CHAPTER V.

## BRIDGES.

554.	Classification of Bridges.....	279
------	--------------------------------	-----

## II. STONE BRIDGES.

555-556.	Location of Stone Bridges.....	279
557-561.	Survey—Management of the Water-way.....	280
562.	Number of Bays.....	282
563-567.	Classification of Arches—Definitions.....	282
568.	Oblique Arches.....	285
569.	Arched Bridges.....	289
570-576.	Centring for Arches.....	289
577.	Style of Architecture.....	294
578-587.	Construction of the Foundations.....	294
588-590.	Superstructure.....	302
591-592.	Approaches—Water-wings.....	305
593-594.	Enlargement of the Water-way—General Remarks.....	306
595-596.	Table of Bridges.....	306

## III. WOODEN BRIDGES.

597-604.	Timber Foundations.....	310
605-606.	Definitions of Terms.....	314
607.	Long's Truss.....	315
608.	Town's Truss.....	316
609.	Howe's Truss.....	317
610.	Schuylkill Bridge.....	317
611.	Burr's Truss.....	318
612.	Pratt's Truss.....	320
613.	McCallum's Truss.....	320
614.	Canal Bridge.....	320
615.	Wooden Arches.....	321
616-621.	General Remarks.....	322
622.	Architecture of Wooden Bridges.....	324
623.	Table of Wooden Bridges.....	324

## IV. CAST-IRON BRIDGES.

624-627.	General Remarks.....	325
628-630.	Cast-iron Arches.....	327

## CONTENTS.

ix

ARTICLE	PAGE
631. Open Cast-iron Beams.....	331
632. Effects of Temperature on Stone and Cast-iron Bridges.....	331

## V. IRON TRUSSED BRIDGES.

633. Whipple's Trapezoidal Truss.....	332
634. Modification of Whipple's Truss.....	334
635. Linville's Bridge.....	334
636. Whipple's Arched Truss.....	337
637. Bollman's Truss.....	337
638. Fink's Truss.....	338
639. Post's Truss.....	339
640. Alleghany River Bridge.....	344
641. St. Louis and Illinois Bridge.....	344
642. Kuilenberg Bridge.....	347

## VI. TUBULAR BRIDGES.

643. Tubular Frames of Wrought Iron.....	347
644. Experiments with a Model Tube.....	349
645. Britannia Tubular Bridge.....	350
646. Formula for Computing the Strength of Wrought-iron Tubes	354
647. Victoria Bridge.....	354

## VII. SUSPENSION BRIDGES.

648-653. General Remarks.....	357
654-655. Anchorage.....	359
656-658. Position and Construction of the Cables.....	360
659. Vertical Suspension Bars.....	361
660-662. Construction of Wire Cables.....	361
663-664. Construction of the Piers and Abutments.....	362
665. Main Chains, &c.....	363
666. Attachment of Suspending Chains.....	364
667. Roadway.....	364
668. Vibrations.....	365
669. Means of Preserving the Chains.....	366
670. Proofs of Suspension Bridges.....	366
671. Durability.....	367
672. Suspension Bridge near Berwick, England.....	368
673. Menai Bridge.....	368
674. Fribourg Bridge.....	370
675. Hungerford and Lambeth Bridge.....	371
676. Monongahela Wire Bridge.....	373
677. Niagara Railroad Suspension Bridge.....	374
678. East River Suspension Bridge.....	379

## VIII. MOVABLE BRIDGES.

679. Definitions.....	380
680. Draw Bridges.....	381
681. Turning Bridges.....	384
682. Swing Bridge at Providence, Rhode Island.....	385
683. Rolling Bridges.....	391
684. Boat Bridges.....	391

ARTICLE.	PAGE.
IX. AQUEDUCT BRIDGES.	
685. General Principles.....	391
686. Canal Aqueducts.....	393
687. Trunk of Cast Iron or Timber.....	393

CHAPTER VI.

ROOFS.

688. Definition.....	393
689. Remark.....	393
690. General Data.....	393
691. Weight of Snow.....	394
692. The Force of Wind.....	394
693. Ordinary Roof Truss.....	394
695. An Iron Roof Truss.....	396
696. Roof of a Gas-House.....	397
697. An Example of Trussing.....	398
698. Depot Roof Truss.....	399
699. Roof of a Rolling Mill.....	400
700. Truss of the State Capitol, Vermont.....	400
701. Example of Roof at the University of Michigan.....	402

CHAPTER VII.

ROADS.

702. Establishing a Common Road.....	403
703. Reconnaissance.....	403
704-708. Surveying and Locating Common Roads.....	405
709. Gradients.....	407
710-713. Final Location.....	408
714-720. Earthwork—Excavations and Embankments.....	411
721. Drainage.....	416
722. Road-coverings.....	419
723. Pavements—Wood and Stone.....	420
724. McAdam and Telford Roads.....	423
726. Gravel Roads.....	425
728. Asphaltic Roads.....	427
729. Repairing Common Roads.....	428
730. Cross Dimensions of Common Roads.....	429
731. Plank Roads.....	430

II. RAILWAYS.

732. Definition.....	430
733-736. Rails.....	430
737. Supports.....	433
738. Ballast.....	434
739. Temporary Railways.....	434
740. Gauge.....	435
742. Curves.....	436
743. Sidings, etc.....	436
746-747. Gradients.....	438
748-753. Tunnels.....	439

ARTICLES.	PAGE.
754-763. Experiments of Baron Von Weber on the Stability of the Permanent Way .....	443
755. Stability of Rails to Lateral Pressure.....	443
756. Stability of the Permanent Way.....	443
757. Stability of the Permanent Way to Resist Horizontal Displacement.....	444
759. Stability of the Rails on the Sleepers.....	448
763-763. Experiments on the Resisting Power of Railway Spikes .....	451
764. Experiments on the Effect of Bed-plates.....	454
765. Force Required to Draw Spikes.....	456
766. Total Resistance due to Spikes and Friction.....	458
768. Weber's Deductions from Tabulated Results.....	461
769. Sleepers.....	463
770. Rail Joints.....	464
771-776. Steel Rails.....	464

## CHAPTER VIII.

## CANALS.

777-780. General Remarks.....	467
781. Cross Section.....	470
782-783. Supply of Water.....	471
784-786. Locks—Use of, etc.....	473
787-793. Feeders and Reservoirs.....	474
794. Lifts of Locks.....	475
795. Levels.....	480
796-815. Locks—Principles of Construction.....	482
816-817. Accessory Works—Culverts.....	488
818-819. Aqueducts—Canal Bridges.....	489
820-822. Waste-weir—Guard Lock .....	490
823. General Dimensions of Canals.....	491
824. Locomotion on Canals.....	493

## CHAPTER IX.

## RIVERS.

825-829. Natural Features of Rivers.....	494
830-831. River Improvements.....	495
833. Means of Protecting the Banks—Inundations .....	498
834-836. Elbows.....	499
837-841. Bars.....	502
842-854. Slack-water Navigation.....	503
855-856. Escapements .....	513
857-881. Dams.....	513

## CHAPTER X.

## SEA-COAST IMPROVEMENTS.

882-886. Classification—Action of Tides .....	534
887-888. Roadsteads.....	536
889-895. Harbors.....	538
896-898. Quays.....	541
899. Dikes.....	542
900. Groins.....	543
901. Sea-walls.....	543



**ELEMENTARY COURSE**  
**OF**  
**CIVIL ENGINEERING.**



**CHAPTER I.**

**BUILDING MATERIALS.**

**I. STONE. II. LIME. III. LIMEKILNS. IV. MORTARS  
V. CONCRETES AND BETONS. VI. MASTICS. VII. BRICK  
VIII. WOOD. IX. METALS. X. PAINTS, VARNISHES  
ETC.**

**SUMMARY.**

**BUILDING-MATERIALS, their properties, application, and classification  
(Arts. 1-3).**

**I**

**STONE.**

**SILICIOUS STONES.**—Sienite, Porphyry, Green-Stone, Granite and Gneiss, Mica Slate, Buhr or Mill Stone, Horn-Stone, Steatite or Soap-Stone, Talcose Slate, and Sand-Stone (Arts. 3-16).

**ARGILLACEOUS STONES.**—Roofing-Slate, Graywacke Slate, and Hornblende Slate (Arts. 17-20).

**CALCAREOUS STONES.**—Common Limestone. **MARBLES.**—Statuary Marble, Conglomerate Marble, Birdseye Marble, Lumachella Marble, Verd Antique Marble, Veined, Golden, Italian, Irish, etc., Marbles. Localities where the Limestones and Marbles are found and quarried for use (Arts. 21-29), Gypsum (Art. 30).

**Durability of Stone (Arts. 31-36).**

**Effects of heat on Stone (Art. 37).**

**Hardness of Stone (Art. 38).**



and mica, the latter predominating. It is used principally as a *flagging* stone, and as a *fire* stone, or lining for furnaces.

12. **Buhr or Mill stone.** This is a very hard, durable stone, presenting a peculiar, honeycomb appearance. It makes a good building material for common purposes, and is also suitable for road coverings.

13. **Horn-stone.** This is a highly silicious and very hard stone. It resembles flint in its structure, and takes its name from its translucent, horn-like appearance. It furnishes a very good road material.

14. **Steatite, or Soap-stone.** This stone is a partially indurated talc. It is a very soft stone, not suitable for ordinary building purposes. It furnishes a good fire-stone, and is used for the lining of fireplaces.

15. **Talcose Slate.** This stone resembles mica slate, being an aggregation of quartz and talc. It is applied to the same purposes as mica slate.

16. **Sand-stone.** This stone consists of grains of silicious sand, arising from the disintegration of silicious rocks, which are united by some natural cement, generally of an argillaceous or a silicious character.

The strength, hardness, and durability of sand-stone vary between very wide limits. Some varieties being little inferior to good granite, as a building stone, others being very soft, friable, and disintegrating rapidly when exposed to the weather. The least durable sand-stones are those which contain the most argillaceous matter; those of a feldspathic character are also found not to withstand well the action of the weather.

Sand-stone is used very extensively as a building stone, for flagging, for road materials, and some of its varieties furnish an excellent fire-stone. Most of the varieties of sand-stone yield readily under the chisel and saw, and split evenly, and, from these properties, have received from workmen the name of *free-stone*. The colors of sand-stone present also a variety of shades, principally of gray, brown, and red.

The formations of sand-stone in the United States are very extensive, and a number of quarries are worked in New England, New York, and the Middle States. These formations, and the character of the stone obtained from them, are minutely described in the *Geological Reports of these States*, which have been published within the last few years.

Most of the stone used for the public buildings in Wash-

## II.

## LIME.

**CLASSIFICATION OF LIME.**—Common lime, Hydraulic lime, Hydraulic cement, Limestones that yield Hydraulic limes and Hydraulic cements, Analyses of these stones (Arts. 39-49). Physical characters and tests of Hydraulic Limestones (Arts. 50-55). Calcination of Limestones (Arts. 56-60).

## III.

## LIMEKILNS.

**CLASSIFICATION AND KINDS OF** (Arts. 61-77). Methods of reducing calcined stone to powder; by slaking; by grinding (Arts. 78-95). Artificial hydraulic limes and cements (Arts. 96-103). Puzzolana, etc. (Arts. 104-114).

## IV.

## MORTAR.

**CLASSIFICATION OF** (Arts. 115-116). Uses of (Art. 117). Qualities of, on what dependent (Arts. 117-120). Classification of Sand (Arts. 121-127). Composition of Hydraulic mortar (Arts. 128-134). Mortar exposed to weather (Arts. 135-138). Manipulation of Mortar and Concrete (Arts. 139-142). Setting and durability of Mortar (Arts. 143-150). Theory of Mortars (151-152).

## V.

## CONCRETES AND BETONS.

**CONCRETE OF COMMON LIME, MANUFACTURE AND USES** (Arts. 154-157). Beton, its composition, manufacture and uses (Arts. 158-161). Beton Coignet (Arts. 162-166). Ransome's artificial stone (Art. 167). Beton aggloméré (Arts. 168-182). Adhesion of Mortar to other materials (Arts. 183-186).

## VI.

## MASTICS.

**MASTICS, COMPOSITION OF** (Art. 187). Bituminous Mastic, Composition and Manufacture of (Arts. 188-193).

## VII.

## BRICK.

**PROPERTIES, USES AND MANUFACTURE OF** (Arts. 199-209) Fire-Brick (Art. 210). Tiles (Art. 211).

## VIII.

## WOOD.

**TIMBER, KINDS OF** (Art. 212). Parts and properties of the trunks of Trees (Arts. 213-214). Felling of Trees (Arts. 215-216). Girdling and barking trunks of Trees (Art. 217). Methods of seasoning Timber (Arts. 224-225). Wet and dry rot (Art. 226). Preservation of Timber (Arts. 227-242). Forest Trees of the United States (Arts. 243-243).

## IX.

## METALS.

**CAST IRON, VARIETIES OF** (Arts. 249-263). Wrought Iron, Varieties of (Arts. 264-277). Durability of Iron (Arts. 278-289). Preservatives of Iron (Arts. 290-298). Corrugated Iron (Art. 299). Steel (Art. 300).

**COPPER** and its alloys (Art. 301).

**ZINC** and its alloys (Art. 302).

**TIN** (Art. 303).

**LEAD** (Art. 304).

## X.

## PAINTS AND VARNISHES.

**PAINTS, COMPOSITION, USES AND DURABILITY OF** (Arts. 305-308). Varnishes, Composition and Uses of (Arts. 309-311). Varnish for Zincked Iron (Arts. 312-313). Zoofagous Paint (Art. 314). Methods of preserving exposed surfaces of Stone (Art. 315).

**L A KNOWLEDGE** of the properties of building materials is one of the most important branches of Civil Engineering. An engineer, to be enabled to make a judicious selection of materials, and to apply them so that the ends of sound economy and skilful workmanship shall be equally subserved, must know:—

1st. Their ordinary durability under the various circumstances in which they are employed, and the means of increasing it when desirable.

2d. Their capacity to sustain, without injury to their physical qualities, permanent strains, whether exerted to crush them, tear them asunder, or to break them transversely.

3d. Their resistance to rupture and wear, from percussion and attrition.

4th. Finally, the time and expense necessary to convert them to the uses for which they may be required.

2. The materials in general use for civil constructions may be arranged under the three following heads:—

1st. Those which constitute the more solid components of structures, as *Stone, Brick, Wood*, and the *Metals*.

2d. The cements in general, as *Mortar, Mastics, Glue*, etc., which are used to unite the more solid parts.

3d. The various mixtures and chemical preparations, as solutions of *Salts, Paints, Bituminous Substances*, etc., employed to coat the more solid parts, and protect them from the chemical and mechanical action of atmospheric changes, and other causes of destructibility.

---

## I.

### STONE.

3. The term *Stone*, or *Rock*, is applied to any aggregation of several mineral substances.

Stones, for the convenience of description, may be arranged under three general heads—the *silicious*, the *argillaceous*, and the *calcareous*.

4. **SILICIOUS STONES.** The stones arranged under this head receive their appellation from *silex*, the principal constituent of the minerals which compose them. They are also frequently designated, either according to the mineral found most abundantly in them, or from the appearance of the stone, as *feldspathic, quartzose, arenaceous*, etc.

5. The silicious stones generally do not effervesce with acids, and emit sparks when struck with a steel. They possess, in a high degree, the properties of strength, hardness, and durability; and, although presenting great diversity in the degree of these properties, as well as in their structure, they furnish an extensive variety of the best stone for the various purposes of the engineer and architect.

6. *Sielite, Porphyry*, and *Green-stone*, from the abun-

dance of feldspar which they contain, are often designated as feldspathic rocks. For durability, strength, and hardness, they may be placed in the first rank of silicious stones.

**7. Sienite** consists of a granular aggregation of feldspar, hornblende, and quartz. It furnishes one of the most valuable building stones, particularly for structures which require great strength, or are exposed to any very active causes of destructibility, as sea walls, lighthouses, and fortifications. Sienite occurs in extensive beds, and may be obtained, from the localities where it is quarried, in blocks of any requisite size. It does not yield easily to the chisel, owing to its great hardness, and when coarse-grained it cannot be wrought to a smooth surface. Like all stones in which feldspar is found, the durability of sienite depends essentially upon the composition of this mineral, which, owing to the potash it contains, sometimes decomposes very rapidly when exposed to the weather. The durability of feldspathic rocks, however, is very variable, even where their composition is the same; no pains should therefore be spared to ascertain this property in stone taken from new quarries, before using it for important public works.

**8. Porphyry.** This stone is usually composed of compact feldspar, having crystals of the same, and sometimes those of other minerals, scattered through the mass. Porphyry furnishes stones of various colors and texture; the usual color being reddish, approaching to purple, from which the stone takes its name. One of the most beautiful varieties is a *brecciated* porphyry, consisting of angular fragments of the stone united by a cement of compact feldspar. Porphyry, from its rareness and extreme hardness, is seldom applied to any other than ornamental purposes. The best known localities of sienite and porphyry in the United States are in the neighborhood of Boston.

**9. Green-stone.** This stone is a mixture of hornblende with common and compact feldspar, presenting sometimes a granular though usually a compact texture. Its ordinary color, when dry, is some shade of brown; but, when wet, it becomes greenish, from which it takes its name. Green-stone is very hard, and one of the most durable rocks; but, occurring in small and irregular blocks, its uses as a building stone are very restricted. When walls of this stone are built with very white mortar, they present a picturesque appearance and it is on that account well adapted to rural architecture. Green-stone might also be used as a material

for road-making; large quantities of it are annually taken from the principal locality of this rock in the United States, so well known as the Palisades, on the Hudson, for constructing wharves, as it is found to withstand well the action of salt water.

**10. Granite and Gneiss.** The constituents of these two stones are the same, being a granular aggregation of quartz, feldspar, and mica, in variable proportions. They differ only in their structure—gneiss being a stratified rock, the ingredients of which occur frequently in a more or less laminated state. Gneiss, although less valuable than granite, owing to the effect of its structure on the size of the blocks which it yields, and from its not splitting as smoothly as granite across its beds of stratification, furnishes a building stone suitable for most architectural purposes. It is also a good flagging material, when it can be obtained in thin slabs.

Granite varies greatly in quality according to its texture and the relative proportion of its constituents. When the quartz is in excess, it renders the stone hard and brittle, and very difficult to be worked with the chisel. An excess of mica usually makes the stone friable. An excess of feldspar gives the stone a white hue, and makes it freer under the chisel. The best granites are those with a fine grain, in which the constituents seem uniformly disseminated through the mass. The color of granite is usually some shade of gray; when it varies from this, it is owing to the color of the feldspar. One of its varieties, known as *Oriental granite*, has a fine reddish hue, and is used chiefly for ornamental purposes. Granite is sometimes mistaken for sienite, when it contains but little mica.

The quality of granite is affected by the foreign minerals which it may contain; hornblende is said to render it tough, and schorl makes it quite brittle. The protoxide and sulphurets of iron are the most injurious in their effects on granite; the former by conversion into a peroxide, and the latter, by decomposing, destroying the structure of the stone, and causing it to break up and disintegrate.

Granite, gneiss, and sienite, differ so little in their essential qualities, as a building material, that they may be used indifferently for all structures of a solid and durable character. They are extensively quarried in most of the New England States, in New York, and in some of the other States intersected by the great range of primitive rocks, where the quarries lie contiguous to tidewater.

**11. Mica Slate.** The constituents of this stone are quartz

ington is a sand-stone obtained from quarries on Acquia Creek and the Rappahannock. Much of this stone is feldspathic, possesses but little strength, and disintegrates rapidly. The red sand-stones which are used in our large cities are either from quarries in a formation extending from the Hudson to North Carolina, or from a separate deposit in the Valley of the Connecticut. The most durable and hard portions of these formations occur in the neighborhood of trap dikes. The fine flagging-stone used in our cities is obtained mostly either from the Connecticut quarries, or from others near the Hudson, in the Catskill group of mountains. Many quarries, which yield an excellent building stone, are worked in the extensive formations along the Appalachian range, which extends through the interior, through New York and Virginia, and the intermediate States.

**17. Argillaceous Stones.** The stones arranged under this head are mostly composed of clay, in a more or less indurated state, and presenting a laminated structure. They vary greatly in strength, and are generally not durable, decomposing in some cases very rapidly, from changes in the metallic sulphurets and salts found in most of them. The uses of this class of stones are restricted to roofing and flagging.

**18. Roofing Slate.** This well-known stone is obtained from a hard, indurated clay, the surfaces of the lamina having a natural polish. The best kinds split into thin, uniform, light slabs; are free from sulphurets of iron; give a clear ringing sound when struck; and absorb but little water. Much of the roofing slate quarried in the United States is of a very inferior quality, and becomes rotten, or decomposes, after a few years' exposure. The durability of the best European slate is about one hundred years; and it is stated that the material obtained from some of the quarries worked in the United States is not apparently inferior to the best foreign slate brought into our markets. Several quarries of roofing slate are worked in the New England States, New York and Pennsylvania.

**19. Graywacke Slate.** The composition of this stone is mostly indurated clay. It has a more earthy appearance than argillaceous slate, and is generally distinctly arenaceous. Its colors are usually dark gray, or red. It is quarried principally for flagging-stone.

**20. Hornblende Slate.** This stone, known also as green-stone slate, properly belongs to the silicious class. It con-

sists mostly of hornblende having a laminated structure. It is quarried chiefly for flagging-stone.

**21. Calcareous Stones.** Lime is the principal constituent of this class, the carbonates of which, known as *limestone* and *marble*, furnish a large amount of ordinary building stone, most of the ornamental stones, and the chief ingredient in the composition of the cements and mortars used in stone and brick work. Limestone effervesces copiously with acids; its texture is destroyed by a strong heat, which also drives off its carbonic acid and water, converting it into *quick lime*. By absorbing water, quick-lime is converted into a *hydrate*, or what is known as *slaked lime*; considerable heat is evolved during this chemical change, and the stone increases in bulk, and gradually crumbles down into a fine powder.

The limestones present great diversity in their physical properties. Some of them seem as durable as the best silicious stones, and are but little inferior to them in strength and hardness; others decompose rapidly on exposure to the weather; and some kinds are so soft, that when first quarried, they can be scratched with the nail, and broken between the fingers.

The limestones are generally impure carbonates; and we are indebted to these impurities for some of the most beautiful, as well as the most valuable materials used for constructions. Those which are colored by metallic oxides, or by the presence of other minerals, furnish the large number of colored and variegated marbles; while those which contain a certain proportion of clay, or of magnesia, yield, on calcination, those cements which, from their possessing the property of hardening under water, have received the various appellations of *hydraulic lime*, *water lime*, *Roman cement*, etc.

Limestone is divided into two principal classes, *granular limestone* and *compact limestone*. Each of these furnishes both the marbles and ordinary building stone. The varieties not susceptible of receiving a polish are sometimes called *common limestone*.

The granular limestones are generally superior to the compact for building purposes. Those which have the finest grain are the best, both for marbles and ordinary building stone. The coarse-grained varieties are frequently friable, and disintegrate rapidly when exposed to the weather. All the varieties, both of the compact and granular, work freely under the chisel and grit-saw, and may be obtained



in blocks of any suitable dimensions for the heaviest structures.

The durability of limestone is very materially affected by the foreign minerals it may contain; the presence of clay injures the stone, particularly when, as sometimes happens, it runs through the bed in very minute veins: blocks of stone having this imperfection soon separate along these veins on exposure to moisture. The protoxide, the proto-carbonate, and the sulphuret of iron, are also very destructive in their effects; frequently causing, by their chemical changes, rapid disintegration.

Among the varieties of impure carbonates of lime, the *magnesian* limestones, called *dolomites*, merit to be particularly noticed. They are regarded in Europe as a superior building material; those being considered the best which are most crystalline, and are composed of nearly equal proportions of the carbonates of lime and magnesia. Some of the quarries of this stone, which have been opened in New York and Massachusetts, have given a different result; the stone obtained from them being, in some cases, extremely friable.

**22. Marbles.**—The term marble is now applied exclusively to any limestones which will receive a polish. Owing to the cost of preparing marble, it is restricted mostly in its uses to ornamental purposes. The marbles present great variety, both in color and appearance, and have generally received some appropriate name descriptive of these accidents.

**23. Statuary Marble** is of the purest white, finest grain, and free from all foreign minerals. It receives that delicate polish, without glare, which admirably adapts it to the purposes of the sculptor, for whose use it is mostly reserved.

**24. Conglomerate Marble.** This consists of two varieties; the one termed *pudding* stone, which is composed of rounded pebbles embedded in compact limestone; the other termed *breccia*, consisting of angular fragments united in a similar manner. The colors of these marbles are generally variegated, forming a very handsome ornamental material.

**25. Bird's-eye Marble.** The name of this stone is descriptive of its appearance, which arises from the cross sections of a peculiar fossil (*fucoides demissus*) contained in the mass, made in sawing or splitting it.

**26. Lumachella Marble.** This is obtained from a limestone having shells embedded in it, and takes its name from this circumstance.

27. **Verd Antique.** This is a rare and costly variety, of a beautiful green color, caused by veins and blotches of *serpentine* diffused through the limestone.

28. The terms *veined, golden, Italian, Irish,* etc., given to the marbles found in our markets are significant of their appearance, or of the localities from which they are procured.

29 Limestone is so extensively diffused throughout the United States, and quarried, either for building stone or to furnish lime, in so many localities, that it would be impracticable to enumerate all within any moderate compass. One of the most remarkable formations of this stone extends, in an uninterrupted bed, from Canada, through the States of Vermont, Mass., Conn., New York, New Jersey, Penn., and Virg., and in all probability much farther south.

Marbles are quarried in various localities in the United States. Among the most noted are the quarries in Berkshire Co., Mass., which furnish both pure and variegated marbles; those on the Potomac, from which the columns of conglomerate marbles were obtained that are seen in the interior of the Capitol at Washington; several in New York, which furnish white, the bird's-eye, and other variegated kinds; and some in Conn., which, among other varieties, furnish a verd antique of handsome quality.

Limestone is burned, either for building or agricultural purposes, in almost every locality where deposits of the stone occur. Thomaston, in Maine, has supplied for some years most of the markets on the sea-board with a material which is considered as a superior article for ordinary building purposes. One of the greatest additions to the building resources of our country was made in the discovery of the hydraulic or water limestones of New York. The preparation of this material, so indispensable for all hydraulic works and heavy structures of stone, is carried on extensively at Rondout, on the Delaware and Hudson canal, in Madison Co., and is sent to every part of the United States, being in great demand for all the public works carried on under the superintendence of our civil and military engineers. A not less valuable addition to our building materials has been made by Prof. W. B. Rogers, who, a few years since, directed the attention of engineers to the dolomites, for their good hydraulic properties. From experiments made by Vicat, in France, who first there observed the same properties in the dolomite, and from those in our country, it appears highly probable that the magnesian limestones, containing a certain proportion of magnesia, will be found fully equal to

the argillaceous, from which hydraulic lime has hitherto been solely obtained.

Both of these limestones belong to very extensive formations. The hydraulic limestones of New York occur in a deposit called the Water-lime Group, in the Geological Survey of New York corresponding to formation VI. of Prof. H. B. Rogers' arrangement of the rocks of Penn. This formation is co-extensive with the Helderberg Range as it crosses New York; it is exposed in many of the valleys of Penn. and Vir., west of the Great Valley. It may be sought for just below or not far beneath the Oriskany sand-stones of the New York Survey, which correspond to formation VII. of Rogers. This sand-stone is easily recognized, being of a yellowish white color, granular texture, with large cavities left by decayed shells. The limestone is usually an earthy drab-colored rock, sometimes a greenish blue, which does not slake after being burned.

The hydraulic magnesian limestones belong to the formations II. and VI. of Rogers; the first of these is the same as the Black River or Mohawk limestone of the New York Survey. It is the oldest fossiliferous limestone in the United States, and occurs throughout the whole bed, associated with the slates which occupy formation III. of Rogers, and are called the Hudson River Group in the New York Survey. This extensive bed lies in the great Appalachian Valley, known as the Valley of Lake Champlain, Valley of the Hudson, as far as the Highlands, Cumberland Valley, Valley of Virginia, and Valley of East Tennessee. The same stone is found in the deposits of some of the western valleys of the mountain region of Penn. and Virginia.

Thus far no deposits of hydraulic limestones have been found on the Pacific Coast.

The importance of hydraulic lime to the security of structures exposed to constant moisture renders a knowledge of the geological positions of those limestones from which it can be obtained an object of great interest. From the results of the various geological surveys made in the United States and in Europe, limestone, possessing hydraulic properties when calcined, may be looked for among these beds which are found in connection with the *shales*, or other argillaceous deposits. The celebrated *Roman* or *Parker's cement*, of England, which, from its prompt induration in water, has become an important article of commerce, is manufactured from nodules of a concretionary argillaceous limestone, called *septaria*, from being traversed by veins of sparry carbonate

of lime. Nodules of this character are found in Mass., and in some other States; and it is probable they would yield, if suitably calcined and ground, an article in nowise inferior to that imported.

**30. GYPSUM, or PLASTER of PARIS.** This stone is a sulphate of lime, and has received its name from the extensive use made of it at Paris, and in its neighborhood, where it is quarried and sent to all parts of the world; being of a superior quality, owing, it is stated, to a certain portion of carbonate of lime which the stone contains. Gypsum is a very soft stone, and is not used as a building stone. Its chief utility is in furnishing a beautiful material for the ornamental casts and mouldings in the interior of edifices. For this purpose it is prepared by calcining, or, as the workmen term it, *boiling* the stone, until it is deprived of its water of crystallization. In this state it is made into a thin paste, and poured into moulds to form the cast, in which it hardens very promptly. Calcined plaster of Paris is also used as a cement for stone; but it is eminently unfit for this purpose; for when exposed, in any situation, to moisture, it absorbs it with avidity, swells, cracks, and exfoliates rapidly.

Gypsum is found in various localities in the United States. Large quantities of it are quarried in New York, both for building and agricultural purposes.

**31. DURABILITY OF STONE.** The most important properties of stone, as a building material, are its durability under the ordinary circumstances of exposure to weather; its capacity to sustain, without change, high degrees of temperature; and its resistance to the destructive action of fresh and salt water.

The wear of stone from ordinary exposure is very variable, depending, not only upon the texture and constituent elements of the stone, but also upon the locality and position it may occupy in a structure, with respect to the prevailing driving rains. The chemist and geologist have not, thus far, laid down any infallible rules to guide the engineer in the selection of a material that may be pronounced durable for the ordinary period allotted to the works of man. In truth the subject admits of only general indications; for stones having the same texture and chemical composition, from causes not fully ascertained, are found to possess very different degrees of duration. This has been particularly noted in feldspathic rocks. As a general rule, those stones which are fine-grained, absorb

least water, and are of greatest specific gravity, are also most durable under ordinary exposures. The weight of a stone, however, may arise from a large proportion of iron in the state of a protoxide, a circumstance generally unfavorable to its durability. Besides the various chemical combinations of iron, potash and clay, when found in considerable quantities, both in the primary and sedimentary silicious rocks, greatly affect their durability. The potash contained in feldspar dissolves, and, carrying off a considerable proportion of the silica, leaves nothing but aluminous matter behind. The clay, on the other hand, absorbs water, becomes soft, and causes the stone to crumble to pieces. Iron in the form of protoxide, in some cases only, discolors the stone by its conversion into a peroxide.— This discoloration, while it greatly diminishes the value of some stones, as in white marble, in others is not disagreeable to the eye, producing often a mottled appearance in buildings which adds to the picturesque effect.

32. Frost, or rather the alternate actions of freezing and thawing, is the most destructive agent of Nature with which the engineer has to contend. Its effects vary with the texture of stones; those of a fissile nature usually splitting, while the more porous kinds disintegrate, or exfoliate at the surface.— When stone from a new quarry is to be tried, the best indication of its resistance to frost may be obtained from an examination of any rocks of the same kind, within its vicinity, which are known to have been exposed for a long period. Submitting the stone fresh from the quarry to the direct action of freezing would seem to be the most certain test, were the stone destroyed by the expansive action of the frost; but besides the uncertainty of this test, it is known that some stones, which, when first quarried, are much affected by frost, splitting under its action, become impervious to it after they have lost the moisture of the quarry, as they do not re-absorb near so large an amount as they bring from the quarry.

33. M. Brard, a French chemist, has given a process for ascertaining the effects of frost on stone, which has met with the approval of many French architects and engineers of standing, as it corresponds with their experience. M. Brard directs that a small cubical block, about two inches on the edge, shall be carefully sawed from the stone to be tested. A cold saturated solution of sulphate of soda is prepared, placed over a fire, and brought to the boiling point. The stone, suspended from a string, is immersed in the boiling liquid, and kept there during thirty minutes; it is then carefully withdrawn; the liquid is decanted free from sediment into a flat

vessel, and the stone is suspended over it in a cool cellar. An efflorescence of the salt soon makes its appearance on the stone, when it must be again dipped into the liquid. This should be done once or more frequently during the day, and the process be continued in this way for about a week. The earthy sediment, found at the end of this period in the vessel, is weighed, and its quantity will give an indication of the like effect of frost. This process, with the official statement of a commission of engineers and architects, by whom it was tested, is minutely detailed in vol. 38, *Annales de Chimie et de Physique*, and the results are such as to commend it to the attention of engineers in submitting new stones to trial.

34. From more recent experiments by Dr. Owen it was found that the results obtained by exposing the more porous stones to the alternate action of freezing and thawing during a portion of a winter were very different from those resulting from Brard's method, owing to the action of the salts being chemical as well as mechanical.

35. By the absorption of water, stones become softer and more friable. The materials for road coverings should be selected from those stones which absorb least water, and are also hard and not brittle. Granite, and its varieties, limestone, and common sand-stone, do not make good road materials of broken stone. All the hornblende rocks, porphyry, compact feldspar, and the quartzose rock associated with graywacke, furnish good, durable road coverings. The fine-grained granites which contain but a small proportion of mica, the fine-grained silicious sand-stones which are free from clay, and carbonate of lime, form a durable material when used in blocks for paving. Mica slate, talcose slate, hornblende slate, some varieties of gneiss, some varieties of sand-stone of a slaty structure, and graywacke slate, yield excellent materials for flag-stone.

36. The influence of locality on the durability of stone is very marked. Stone is observed to wear more rapidly in cities than in the country; and the stone in those parts of edifices exposed to the prevailing rains and winds, soonest exhibits signs of decay. The disintegration of the stratified stones placed in a wall is mainly effected by the position which the strata or *quarry bed* receives, with respect to the exposed surface; proceeding faster when the faces of the strata are exposed, than in the contrary position.

37. **EFFECTS OF HEAT.**—Stones which resist a high degree of heat without fusing are used for lining furnaces,

and are termed fire-stones. A good fire-stone should not only be infusible, but also not liable to crack or exfoliate from heat. Stones that contain lime, or magnesia, except in the form of silicates, are usually unsuitable for fire-stones. Some porous silicious limestones, as well as some gypsous silicious rocks, resist moderate degrees of heat. Stones that contain much potash are very fusible under high temperatures, running into a glassy substance. Quartz and mica, in various combinations, furnish a good fire-stone; as, for example, finely granular quartz with thin layers of mica, mica slate of the same structure, and some kinds of gneiss which contain a large proportion of arenaceous quartz. Several varieties of sand-stone make a good lining for furnaces. They are usually those varieties which are free from feldspar, somewhat porous, and are uncrystallized in the mass. Talcose slate likewise furnishes a good fire-stone.

**33. RESISTANCE TO ATTRITION.**—Hardness is an essential quality in stone exposed to wear from the attrition of hard bodies. Stones selected for paving, flagging, and steps for stairs, should be hard, and of a grain sufficiently coarse not to admit of becoming very smooth under the action to which they are submitted. As great hardness adds to the difficulty of working stone with the chisel, and to the cost of the prepared material, builders prefer the softer or *free-stones*, such as the limestones and sand-stones, for most building purposes. The following are some of the results, on this point, obtained from experiment :

*Table showing the result of experiments made under the direction of Mr. Walker, on the wear of different stones in the tramway on the Commercial Road, London, from 27th March, 1830, to 24th August, 1831, being a period of seventeen months. Transactions of Civil Engineers, vol. 1.*

Name of stone.	Sup. area in feet.	Original weight.			Loss of weight by wear.	Loss per sup. foot.	Relative losses.
		cwt.	qrs.	lbs.			
Guernsey . . . .	4.734	7	1	12.75	4.50	0.951	1.000
Herne . . . . .	5.250	7	3	24.25	5.50	1.048	1.102
Budle . . . . .	6.336	9	0	15.75	7.75	1.223	1.286
Peterhead (blue) .	3.484	4	1	7.50	6.25	1.795	1.887
Heytor . . . . .	4.313	6	0	15.25	8.25	1.915	2.014
Aberdeen (red) . .	5.375	7	2	11.50	11.50	2.139	2.249
Dartmoor . . . . .	4.500	6	2	25.00	12.50	2.778	2.921
Aberdeen (blue) .	4.823	6	2	16.00	14.75	3.058	3.216

The Commercial Road stoneway consists of two parallel lines of rectangular tramstones, 18 inches wide by 12 inches deep, and jointed to each other endwise, for the wheels to travel on, with a common street pavement between for the horses.

The following table gives the results of some experiments on the wear of a fine-grained sand-stone pavement, by M. Coriolis, during eight years, upon the paved road from Paris to Toulouse, the carriage over which is about 500 tons daily, published in the *Annales des Ponts et Chaussées*, for March and April, 1834:

Weight of a cubic foot	Volume of water absorbed by the dry stone after one day's immersion, compared with that of the stone.	Mean annual wear.
158lbs.	Neglected as insensible.	0.1023 inch.
154 "	"	0.1063 "
156 "	"	0.1299 "
150 "	$\frac{1}{2}$ in volume.	0.2126 "
148 "	$\frac{1}{3}$ "	0.2677 "

M. Coriolis remarks, that the weight of water absorbed affords one of the best indications of the durability of the fine-grained sand-stones used in France for pavements. An equally good test of the relative durability of stones of the same kind, M. Coriolis states, is the more or less clearness of sound given out by striking the stone with a hammer.

The following results are taken from an article by Mr. James Frost, *Civ. Engineer*, inserted in the *Journal of the Franklin Institute* for Oct. 1835, on the resistance of various substances to abrasion. The substances were abraded against a piece of white statuary marble, which was taken as a standard, represented by 100, by means of fine emery and sand. The relative resistance was calculated from the weight lost by each substance during the operation.

*Comparative Resistance to Abrasion.*

Aberdeen granite.....	980
Hard Yorkshire paving stone.....	327
Italian black marble.....	260
Kilkenny black marble.....	110
Statuary Marble.....	100
Old Portland stone.....	79
Roman Cement stone.....	69
Fine-grained Newcastle grindstone.....	53
Stock brick.....	34
Coarse-grained Newcastle grindstone.....	14
Bath stone.....	12



## II.

## LIME.

38. **CLASSIFICATION OF LIME.**—Considered as a building material, lime is now usually divided into three principal classes: *Common or Air lime*, *Hydraulic lime*, and *Hydraulic*, or *Water cement*.

39. Common, or air lime, is so called because the paste made from it with water will harden only in the air.

40. Hydraulic lime and hydraulic cement both take their name from hardening under water. The former differs from the latter in two essential points. It slakes thoroughly, like common lime, when deprived of its carbonic acid, and it does not harden promptly under water. Hydraulic cement, on the contrary, does not slake, and usually hardens very soon.

41. Our nomenclature, with regard to these substances, is still quite defective for scientific arrangement. For the limestones which yield hydraulic lime when completely calcined, also give an hydraulic cement when deprived of a portion only of their carbonic acid; and other limestones yield, on calcination, a result which can neither be termed lime nor hydraulic cement, owing to its slaking very imperfectly, and not retaining the hardness which it quickly takes when first placed under water.

M. Vicat, whose able researches into the properties of lime and mortars are so well known, has proposed to apply the term *cement limestones* (*calcaires à ciment*) to those stones which, when completely calcined, yield hydraulic cement, and which under no degree of calcination will give hydraulic lime. For the limestones which yield hydraulic lime when completely calcined, and which, when subjected to a degree of heat insufficient to drive off all their carbonic acid, yield hydraulic cement, he proposes to retain the name hydraulic limestones; and to call the cement obtained from their incomplete calcination *under-burnt hydraulic cement* (*ciments d'incuits*), to distinguish it from that obtained from the cement stone. With respect to those limestones which, by calcination, give a result that partakes partly of the properties both of limes and cements, he proposes for them the name of *dividing limes* (*chaux limites*.)

The terms *fat* and *meager* are also applied to limes; owing to the difference in the quality of the paste obtained from them with the same quantity of water. The fat limes give a

paste which is unctuous both to the sight and touch. The meager limes yield a thin paste. These names were of some importance when first introduced, as they served to distinguish common from hydraulic lime, the former being always fat, the latter meager; but, later experience having shown that all meager limes are not hydraulic, the terms are no longer of use, except to designate qualities of the paste of limes.

42. **Hydraulic Limes and Cements.** The limestones which yield these substances are either *argillaceous*, or *magnesian*, or *argillo-magnesian*. The products of their calcination vary considerably in their hydraulic properties. Some of the hydraulic limes harden, or *set* very slowly under water, while others set rapidly. The hydraulic cements set in a very short time. This diversity in the hydraulic energy of the argillaceous limestones arises from the variable proportions in which the lime and clay enter into their composition.

43. M. Petot, a civil engineer in the French service, in an able work entitled *Recherches sur la Chauffournerie*, gives the following table, exhibiting these combinations, and the results obtained from their calcination.

Lime.	Clay.	Resulting products.	Distinctive characters of the products.
100	0	Very fat lime.	Incapable of hardening in water.
90	10	Lime a little hydraulic.	} Slakes like pure lime, when properly calcined, and hardens under water.
80	20	do. quite hydraulic.	
70	30	do. do.	} Does not slake under any circumstances, and hardens under water with rapidity.
60	40	Plastic, or hydraulic cement.	
50	50	do.	} Does not slake nor harden under water, unless mixed with a fat or an hydraulic lime.
40	60	do.	
30	70	Calcareous puzzolane (brick).	} Same as the preceding.
20	80	do. do.	
10	90	do. do.	
0	100	Puzzolane of pure clay do.	

44. The most celebrated European hydraulic cements are obtained from argillaceous limestones, which vary but slightly in their constituent elements and properties. The following table gives the results of analyses to determine the relative proportions of lime and clay in these cements.

*Table of Foreign Hydraulic Cements, showing the relative proportions of Clay and Lime contained in them.*

LOCALITY.	Lime.	Clay.
English, (commonly known as Parker's, or Roman cement). . . . .	55.40	44.60
French, (made from Boulogne pebbles). . . . .	54.00	46.00
Do. (Pouilly). . . . .	49.86	57.14
Do. do. . . . .	86.87	63.63
Do. (Baye) . . . . .	21.62	78.38
Russian. . . . .	62.00	88.00

The hydraulic cements used in England are obtained from various localities, and differ but little in the relative proportions of lime and clay found in them. Parker's cement, so called from the name of the person who first introduced it, is obtained by calcining nodules of *septaria*. The composition of these nodules is the same as that of the *Boulogne pebbles* found on the opposite coast of France. The stones which furnish the English and French hydraulic cements contain but a very small amount of magnesia.

45. A hydraulic cement known as natural *Portland cement* is manufactured in France, at Boulogne, where the stone, which is very soft, is found underlying the strata which furnish the Boulogne pebbles.

46. The best known hydraulic cements of the United States are manufactured in the State of New York. The following analyses of some of the hydraulic limestones, from the most noted localities, published in the *Geological Report of the State of New York*, 1839, are given by Dr. Beck.

*Analysis of the Manlius Hydraulic Limestone.*

Carbonic acid. . . . .	39.80
Lime . . . . .	26.24
Magnesia. . . . .	18.80
Silica and alumina. . . . .	13.50
Oxide of iron. . . . .	1.25
Moisture and loss. . . . .	1.41
	100.00

This stone belongs to the same bed which yields the hydraulic cement obtained near Kingston, in Upper Canada.

*Analysis of the Chittenango Hydraulic Limestone, before and after calcination.*

	Unburnt.		Burnt.
Carbonic acid.....	39.33	Carbonic acid and moisture..	10.90
Lime.....	25.00	Lime.....	39.50
Magnesia.....	17.83	Magnesia.....	22.27
Silica.....	11.76	Silica.....	16.56
Alumina.....	2.73	Alumina and oxide of iron..	10.77
Peroxide of iron.....	1.50		
Moisture.....	1.50		100.00
	100.00		

*Analysis of the Hydraulic Limestone from Ulster Co., along the line of the Delaware and Hudson Canal, before and after burning.*

	Unburnt.	Burnt.
Carbonic acid.....	34.20	5
Lime.....	25.50	37.60
Magnesia.....	12.35	16.65
Silica.....	15.37	22.75
Alumina.....	9.13	13.40
Oxide of Iron.....	2.25	3.30
Bituminous matter, moisture, and loss.....	1.20	1.30
	100.00	100.00

The hydraulic cement from this last locality has become generally well known, having been successfully used for most of the military and civil public works on the sea-board.

From the results of the analyses of all the above lime stones, it appears that the proportions of lime and clay contained in them place them under the head of hydraulic cements, according to the classification of M. Petot. They do not slake, and they all set rapidly under water.

47. The discovery of the hydraulic properties of certain magnesian limestones is of recent date, and is due to M. Vicat, who first drew attention to the subject. M. Vicat inclines to the opinion that magnesia alone, without the presence of some clay, will yield only a feeble hydraulic lime. He states, that he has never been able to obtain any other, from proceeding synthetically with common lime and magnesia; and that he knows of no well-authenticated instance in which any of the dolomites, either of the primitive or transition formations, have yielded a good hydraulic lime. The stones from these formations, he states, are devoid of

clay; being very pure crystalline carbonates, or else contain siliceous matter only in the state of fine sand. From M. Vicat's experiments it is rendered certain that carbonate of magnesia in combination with carbonate of lime, in proportion of 40 parts of the latter to from 30 to 40 of the former, will produce a feebly hydraulic lime, which does not appear to increase in hardness after it has once set; but that, with the same proportions, some hundredths of clay are requisite to give hydraulic energy to the compound. This proportion of clay M. Vicat supposes may cause the formation of triple *hydro-silicates* of lime, alumina, and magnesia, having all the characteristic properties of good hydraulic lime.

48. The hydraulic properties of the magnesian limestones of the United States were noticed by Professor W. B. Rogers, who, in his *Report of the Geological Survey of Virginia*, 1838, has given the following analyses of some of the stones from different localities.

	No. 1.	No. 2.	No. 3.	No. 4.
Carbonate of lime .....	55.80	53.23	48.20	55.03
Carbonate of magnesia .....	39.20	41.00	35.76	24.16
Alumina and oxide of iron .....	1.50	0.80	1.20	2.60
Silicia and insoluble matter .....	2.50	2.80	12.10	15.30
Water .....	0.40	0.40	2.73	1.20
Loss .....	0.60	1.77	0.01	1.71
	100.00	100.00	100.00	100.00

The limestone No. 1 of the above table is from Sheppards-town on the Potomac, in Virginia; it is extensively manufactured for hydraulic cement. No. 2 is from the Natural Bridge, and banks of Cedar Creek, Virginia; it makes a good hydraulic cement. No. 3 is from New York, and is extensively burnt for cement. No. 4 is from Louisville, Kentucky; said to make a good cement.

49. M. Vicat states, that a magnesian limestone of France, containing the following constituents, lime 40 parts, magnesia 21, and silicia 21, yields a good hydraulic cement; and he gives the following analysis of a stone which gives a good hydraulic lime.

Carbonate of lime .....	50.60
Carbonate of magnesia .....	42.00
Silicia .....	5.00
Alumina .....	2.00
Oxide of iron .....	0.40
	100.00
	-- --

By comparing the constituents of these last two stones with the analyses of the cement-stones of New York, and the magnesian hydraulic limestones of Prof. Rogers, it will be seen that they consist, respectively, of nearly the same combinations of lime, magnesia, and silica.

Although not brought out in the analysis of the preceding stones, there is probably none in which the alkaline salts do not occur, and, in some, of sufficient amount to injure mortar made from them, by their efflorescence.

**50. PHYSICAL CHARACTERS AND TESTS OF HYDRAULIC LIMESTONES.** The simple external characters of a limestone, as color, texture, fracture, and taste, are insufficient to enable a person to decide whether it belongs to the hydraulic class; although they assist conjecture, particularly if the rock, from which the specimen is taken, is found in connection with the clay deposits, or if it belong to a stratum whose general level and characteristics are the same as the argillo-magnesian rocks. These rocks are generally some shade of drab, or of gray, or of a dark grayish-blue; have a compact texture; fracture even or conchoidal; with a clayey or earthy smell and taste. Although the hydraulic limestones are usually colored, still it may happen that the stone may be of a pure white, arising from the combination of lime with a pure clay.

The difficulty of pronouncing upon the class to which a limestone belongs, from its physical properties alone, renders it necessary to resort to a chemical analysis, and even to direct experiment to decide the question.

51. A prejudice exists among lime manufacturers and builders in favor of the dark-colored products of calcined hydraulic limestones, but without any foundation, so far as experiment goes, as some of the most celebrated cements are light colored. As a general rule, a dark-colored material is an unfavorable sign, as showing the presence of some foreign ingredient.

52. In making a complete chemical analysis of a limestone, more skill in chemical manipulations is requisite than engineers usually possess; but a person who has the ordinary elementary knowledge of chemistry can readily ascertain the quantity of clay or of magnesia contained in a limestone, and from these two elements can pronounce, with tolerable certainty, upon its hydraulic properties. To arrive at this conclusion, a small portion of the stone to be tested—about five drachms—is taken and reduced to a powder; this is placed

in a capsule, or an ordinary watch crystal, and slightly diluted muriatic acid is poured over it until it ceases to effervesce. The capsule is then gently heated, and the liquor evaporated, until the residue in the capsule has acquired the consistence of thin paste. This paste is thrown into a pint of pure water and well shaken up, and the mixture is then filtered. The residue left on the filtering paper is thoroughly dried, by bringing it to a red heat; this being weighed will give the clay, or insoluble matter, contained in the stone. It is important to ascertain the state of mechanical division of the insoluble matter thus obtained; for if it be wholly granular, the stone will not yield hydraulic lime. The granular portion must therefore be carefully separated from the other before the latter is dried and weighed.

53. If the sample tested contains magnesia, an indication of this will be given by the slowness with which the acid acts; if the quantity of magnesia be but little, the solution will at first proceed rapidly and then become more sluggish. To ascertain the quantity of magnesia, clear lime-water must be added to the filtered solution as long as any precipitate is formed, and this precipitate must be quickly gathered on filtering paper, and then be washed with pure water. The residue from this washing is the magnesia. It must be thoroughly dried before being weighed, to ascertain its proportion to the clay.

54. Having ascertained, by the preceding analysis, the probable hydraulic energy of the stone, a sample of it should also be submitted to direct experiment. This may be likewise done on a small scale. A sample of the stone must be reduced to fragments about the size of a walnut. A crucible, perforated with holes for the free admission of air, is filled with these fragments, and placed over a fire sufficiently powerful to drive off the carbonic acid of the stone. The time for effecting this will depend on the intensity of the heat. When the heat has been applied for three or four hours, a small portion of the calcined stone may be tried with an acid, and the degree of the calcination may be judged of by the more or less copiousness of the effervescence that ensues. If no effervescence takes place, the operation may be considered completed. The calcined stone should be tried soon after it has become cold; otherwise, it should be kept in a glass jar made as air tight as practicable until used.

55. When the calcined stone is to be tried, it is first slaked by placing it in a small basket, which is immersed for five or six seconds in pure water. The stone is emptied from the

basket so soon as the water has drained off, and is allowed to stand until the slaking is terminated. This process will proceed more or less rapidly, according to the quality of the stone, and the degree of its calcination. In some cases, it will be completed in a few minutes; in others, portions only of the stone will fall to powder, the rest crumbling into lumps which slake very sluggishly; while other varieties, as the true cement stones, give no evidence of slaking. If the stone slakes either completely or partially, it must be converted into a paste of the consistence of soft putty, being ground up thoroughly, if necessary, in an iron mortar. The paste is made into a cake, and placed on the bottom of an ordinary tumbler, care being taken to make the diameter of the cake the same as that of the tumbler. The vessel is filled with water, and the time of immersion noted. If the lime is only moderately hydraulic, it will have become hard enough at the end of fifteen or twenty days, to resist the pressure of the finger, and will continue to harden slowly, more particularly from the sixth or eighth month after immersion; and at the end of a year it will have acquired the consistency of hard soap, and will dissolve slowly in pure water. A fair hydraulic lime will have hardened so as to resist the pressure of the finger, in about six or eight days after immersion, and will continue to grow harder until from six to twelve months after immersion; it will then have acquired the hardness of the softest calcareous stones, and will be no longer soluble in pure water. When the stone is eminently hydraulic, it will have become hard in from two to four days after immersion, and in one month it will be quite hard and insoluble in pure water; after six months, its hardness will be about equal to the more absorbent calcareous stones; and it will splinter from a blow, presenting a slaty fracture.

As the hydraulic cements do not slake perceptibly, the burnt stone must first be reduced to a fine powder before it is made into a paste. The paste, when kneaded between the fingers, becomes warm, and will generally set in a few minutes, either in the open air or in water. Hydraulic cements are far more sparingly soluble in pure water than the hydraulic lime; and the action of pure water upon them ceases, apparently, after a few weeks' immersion in it.

**56. Calcination of Limestone.** The effect of heat on lime-stones varies with the constituent elements of the stone. The pure limestones will stand a high degree of temperature without fusing, losing only their carbonic acid and water. The impure stones containing silica fuse completely under a great heat, and become more or less vitrified when the tem-



perature much exceeds a red heat. The action of heat on the impure limestones, besides driving off their carbonic acid and water, modifies the relations of their other chemical constituents. The argillaceous stones, for example, yield an insoluble precipitate when acted on by an acid before calcination, but are perfectly soluble afterwards, unless the siliceous matter they contain happens to be in the form of grains.

57. The calcination of the hydraulic limestones, from their fusible nature, requires to be conducted with great care; for, if not pushed far enough, the under-burnt portions will not slake; and, if carried too far, the stone becomes *dead* or sluggish; slakes very slowly and imperfectly at first; and, if used in this state for masonry, may do injury by the swelling which accompanies the after-slaking.

58. The more or less facility with which the impure limestones can be burned depends upon several causes; as the compactness of the stone, the size of the fragments submitted to heat, and the presence of a current of air, or of aqueous vapor. The more compact stones yield their carbonic acid less readily than those of an opposite texture. Stones which, when broken into very small lumps, can be calcined under the red heat of an ordinary fire in a few hours, will require a far greater degree of temperature, and for a much longer period, when broken into fragments of six or eight inches in diameter. This is particularly the case with the impure limestones, which, when in large lumps, vitrify at the surface before the interior is thoroughly burnt.

59. If a current of vapor is passed over the stone after it has commenced to give off its carbonic acid, the remaining portion of the gas which, under ordinary circumstances, is expelled with great difficulty, particularly near the end of the process of calcination, will be carried off much sooner. The influence of an aqueous current is attributed, by M. Gay-Lussac, purely to a mechanical action, by removing the gas as it is evolved, and his experiments go to show that a like effect is produced by an atmospheric current. In burning the impure limestones, however, an aqueous current produces the farther beneficial effect of preventing the vitrification of the stone when the temperature has become too elevated; but as the vapor, on coming in contact with the heated stone, carries off a large portion of the heat, this, together with the latent heat contained in it, may render its use in some cases far from economical.

60. Wood, charcoal, peat, the bituminous and the anthracite coals are used for fuel in lime-burning. M. Vicat states,

that wood is the best fuel for burning hydraulic limestones ; that charcoal is inferior to bituminous coal ; and that the results from this last are very uncertain. When wood is used, it should be dry and split up, to burn quickly and give a clear blaze. The common opinion among lime-burners, that the greener the fuel the better, and that the limestone should be watered before it is placed in the kiln, is wrong ; as a large portion of the heat is consumed in converting the water in both cases into vapor. Coal is a more economical fuel than wood, and is therefore generally preferred to it ; but it requires particular care in ascertaining the proper quantity for use.

### III.

#### LIME KILNS.

**LIME KILNS.** Great diversity is met with in the forms and proportions of lime-kilns. Wherever attention has been paid to economy in fuel, the *cylindrical*, *ovoidal*, or the *inverted conical* form has been adopted. The two first being preferred for wood and the last for coal.

61. The whole of the burnt lime is either drawn from the kiln at once, or else the burning is so regulated, that fresh stone and fuel are added as the calcined portions are withdrawn. The latter method is usually followed when the fuel used is coal. The stone and coal, broken into proper sizes (Fig. 1), and in proportions determined by experiment, are



Fig. 1 represents a vertical section through the axis and centre lines of the entrances communicating with the interior of a kiln for burning lime with coal.

A, solid masonry of the kiln, which is built up on the exterior like a square tower, with two arched entrances at B, B on opposite sides.

C, interior of the kiln, lined with fire-brick or stone.

D, ash-pit.

c, c, openings between B, B and the interior through which the burnt lime is drawn.

placed in the kiln in alternate layers ; the coal is ignited at the bottom of the kiln, and fresh strata are added at the top, as the burnt mass settles down and is partially withdrawn at the

bottom. Kilns used in this way are called *perpetual kilns*; they are more economical in the consumption of fuel than those in which the burning is intermitted, and which are, on this account, termed *intermittent kilns*. Wood may also be used as fuel in perpetual kilns; but not with such economy as coal; it moreover presents many inconveniences, in supplying the kiln with fresh stone, and in regulating its discharge. The inverted conical-shaped kiln is generally adopted for coal, and the ovoidal-shaped for wood.

62. Some care is requisite in filling the the kiln with stone when a wood fire is used. A dome (Fig. 2) is formed of the

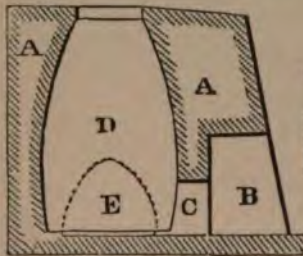

Fig. 2 represents a vertical section through the axis and centre line of the entrance of a lime-kiln for wood. A, solid masonry of the kiln. B, arched entrance. C, doorway for drawing kiln and supplying fuel. D, interior of kiln. E, dome of broken stone, shown by the dotted line.

largest blocks of the broken stone, which either rests on the bottom of the kiln or on the ash-grate. The lower diameter of the dome is a few feet less than that of the kiln; and its interior is made sufficiently capacious to receive the fuel which, cut into short lengths, is placed up endwise around the dome. The stone is placed over and around the courses which form the dome, the largest blocks in the centre of the kiln. The management of the fire is a matter of experiment. For the first eight or ten hours it should be carefully regulated, in order to bring the stone gradually to a red heat. By applying a high heat at first, or by any sudden increase of it until the mass has reached a nearly uniform temperature, the stone is apt to shiver, and choke the kiln, by stopping the voids between the courses of stone which form the dome. After the stone is brought to a red heat, the supply of fuel should be uniform until the end of the calcination. The practice sometimes adopted, of abating the fire towards the end, is bad, as the last portions of carbonic acid retained by the stone, require a high degree of heat for their expulsion. The indications of complete calcination are generally manifested by the diminution which gradually takes place in the mass, and which, at this stage, is about one sixth of the primitive volume; by the broken appearance of the stone which forms the dome, the

interstices between which being also choked up by fragments of the burnt stone; and by the ease with which an iron bar may be forced down through the burnt stone in the kiln. When these indications of complete calcination are observed, the kiln should be closed for ten or twelve hours, to confine the heat and finish the burning of the upper strata.

63. The form and relative dimensions of a kiln for wood can be determined only by careful experiment. If too great height be given to the mass, the lower portions may be overburned before the upper are burned enough. The proportions between the height and mean horizontal section, will depend upon the texture of the stone; the size of the fragments into which it is broken for burning; and the more or less facility with which it vitrifies. In the memoir of M. Petot, already cited, it is stated as the result of experiments made at Brest, that large-sized kilns are more economical, both in the consumption of fuel and in the cost of attendance, than small ones; but that there is no notable economy in fuel when the mean horizontal section of the kiln exceeds sixty square feet.

64. The circular seems the most suitable form for the horizontal sections of a kiln, both for strength and economizing the heat. Were the section the same throughout, or the form of the interior of the kiln cylindrical, the strata of stone, above a certain point, would be very imperfectly burned when the lower were enough so, owing to the rapidity with which the inflamed gases, arising from the combustion, are cooled by coming into contact with the stone. To procure, therefore, a temperature throughout the heated mass which shall be nearly uniform, the horizontal sections of the kiln should gradually decrease from the point where the flame rises, which is near the top of the dome of broken stone, to the top of the kiln. This contraction of the horizontal section, from the bottom upward, should not be made too rapidly, as the draft would be injured, and the capacity of the kiln too much diminished; and in no case should the area of the top opening be less than about one fourth the area of the section taken near the top of the dome. The best manner of arranging the sides of the kiln, in the plane of the longitudinal section, is to connect the top opening with the horizontal section through the top of the dome, by an arc of a circle whose tangent at the lower point shall be vertical.

65. Lime-kilns are constructed either of brick or of some of the more refractory stones. The walls of the kiln should be sufficiently thick to confine the heat, and, when the locality

admits of it they are built into a side hill; otherwise, it may be necessary to use iron hoops, and vertical bars of iron, to strengthen the brick-work. The interior of the kiln should be faced either with good fire-brick or with fire-stone.

66. M. Petot prefers kilns arranged with fire-grates, and an ash-pit under the dome of broken stone, for the reason that they give the means of better regulating the heat, and of throwing the flame more in the axis of the kiln than can be done in kilns without them. The action of the flame is thus more uniformly felt through the mass of stone above the top of the dome, while that of the radiated heat upon the stone around the dome is also more uniform.

67. M. Petot states, that the height of the mass of stone above the top of the dome should not be greater than from ten to thirteen feet, depending on the more or less compact texture of the stone, and the more or less ease with which it vitrifies. He proposes to use kilns with two stories (Fig. 3),

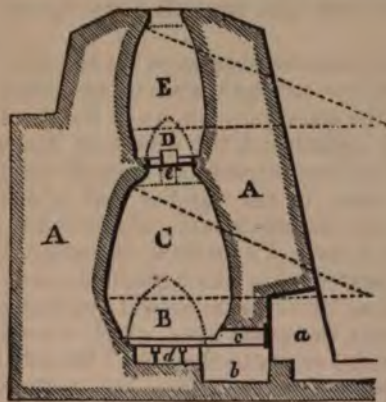

Fig. 3 represents a vertical section through the axis and centre line of the entrance of a lime-kiln with two stories for wood.

- A, solid masonry of the kiln.
- B, dome shown by the dotted line.
- C, interior of lower story.
- D, dome of upper story.
- E, interior of upper story.
- a, arched entrance to kiln.
- b, receptacle for water to furnish a current of aqueous vapor.
- c, doorway for drawing kiln, etc., closed by a fire-proof door.
- d, ash-pit under fire-grate.
- e, upper doorway for drawing kiln, etc.

for the purpose of economizing the fuel, by using the heat which passes off from the top of the lower story, and would otherwise be lost, to heat the stone in the upper story; this story being arranged with a side-door, to introduce fuel under its dome of broken stone, and complete the calcination when that of the stone in the lower story is finished.

M. Petot gives the following general directions for regulating the relative dimensions of the parts of the kiln. The greatest horizontal section of the kiln is placed rather below the top of broken stone; the diameter of this section being 1.82, the diameter of the grate. The height of the dome

above the grate is from 3 to 6 feet, according to the quantity of fuel to be consumed hourly. The bottom of the kiln, on which the piers of the dome rest, is from 4 to 6 inches above the top of the grate; the diameter of the kiln at this point being about 2 feet 9 inches greater than that of the grate. The diameter of the horizontal section at top is 0.63 the diameter of the greatest horizontal section. The horizontal sections of the kiln diminish from the section near the top of the dome to the top and bottom of the kiln; the sides of the kiln receiving the form shown in Fig. 3: the object of contracting the kiln towards the bottom being to allow the stone near the bottom to be thoroughly burned by the radiated heat. The grate is formed of cast-iron bars of the usual form, the area of the spaces between the bars being one fourth the total area of the grate. The bottom of the ash-pit, which may be on the same level as the exterior ground, is placed 18 inches below the grate; and at the entrance of the ash-pit is placed a reservoir for water, about 18 inches in depth, to furnish an aqueous current. The draft through the grate is regulated by a lateral air channel to the ash-pit, which can be totally or partially shut by a valve; the area of the cross section of this channel is one tenth the total area of the grate. A square opening, 16 inches wide, the bottom of which is on a level with the bottom of kiln, leads to the dome for the supply of the fuel. This opening is closed with a fire-proof and air-tight door.

In arranging a kiln with two stories, M. Petot states, that the grates of the upper story are so soon destroyed by the heat, that it is better to suppress them, and to place the fuel for completing the calcination of the stone of this story on the top of the burnt stone of the lower story.

68. Lime burning has become a special branch of industry in the United States, in which a large amount of capital is embarked, so that the engineer has now no other concern in the manufacture of this material than to be able to test and select from the samples offered him to suit the application he intends making of his material.

69. There are two principal classes of lime-kilns employed by the manufacturers of lime in the United States. These vary but little from each other in form and dimensions in the localities in which they are used throughout the country.

70. The first class belongs to the *perpetual kilns*, the stone and fuel, which is usually bituminous or anthracite coal, being placed in the kiln in alternate layers, in proportions pointed out by experience, which is fed in like manner at the

top as the calcined stone is gradually drawn out at the bottom. In some cases the chamber of these kilns is simply an inverted frustum of a cone in form.

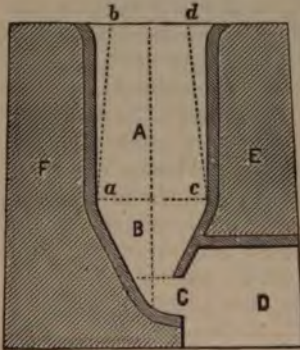

Fig. 4 represents a section through the axis of the perpetual lime-kilns in ordinary use in the United States for coal as the fuel.

A, body of the kiln.

B, thimble, or lower frustum.

C, D, draw pit.

F, body of the masonry.

a b, c d, sides of conical-shaped kiln.

71. In others (Fig. 4) the body or upper portion of the chamber is cylindrical, whilst the lower portion is an inverted conical frustum, the two surfaces being united by an annular one tangent to each.

72. The second class is the flume or furnace kiln. In this the stone placed in the chamber of the kiln is calcined by the combustion of the fuel, either wood or coal, placed in furnaces near the bottom of the chamber. This class may be used either as intermittent or perpetual kilns.

73. In both classes the stone for burning is broken into lumps, none of which should be over eight inches in size in any direction. In the selection of the lumps great care and experience are required on the part of the kiln attendants, in order to obtain a product of uniform quality, as admixtures of stones varying in any important degree in their constituent elements, particularly in those of hydraulic limestones, may so vitiate the results as to render them useless for hydraulic structures.

74. In others they are formed of the frusta of two conical surfaces, as shown by the dotted lines *a b, c d*, united at their larger bases (Fig. 4).

The diameter *a c* of the thimble varies from eight to ten feet; the diameter at the bottom from eighteen inches to three feet; the height of the thimble from seven to ten feet. The upper diameter of the body of the kiln, if conical, is about 8

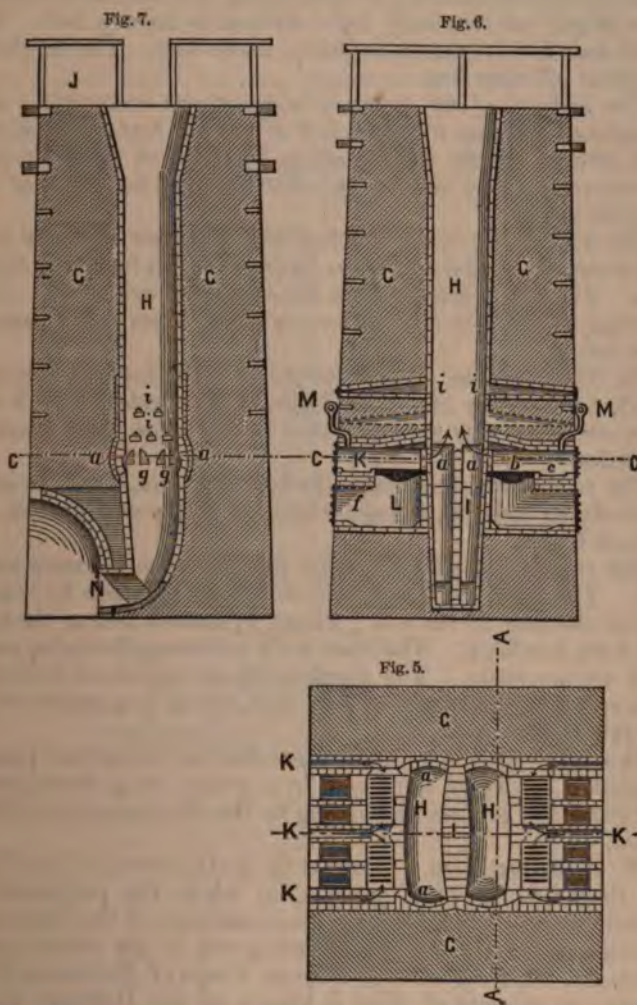

Fig. 5 is a horizontal section taken at CC, Figs. 6, 7; Fig. 6 is a vertical section taken at KK, Fig. 5, through the main furnace; and Fig. 7 a vertical section through

- A A of the water flame kiln for coal.
- H, H is the cupola or body of the kiln.
- I, wall dividing the cupola, and rising from bottom of kiln to a level with the side-flues.
- J, wooden crib on top.
- K, furnace arches.
- L, ash pit.
- M, water-pipes for supplying water-pans *c* and ash pans *f*.
- N, curved iron lining at bottom serving as a slide.
- a, a*, concaves in interior of cupola.
- b, b*, grates.
- c, c*, hot-water coal-pans.
- i, i*, sight-holes for examining burning of body of lime and punching it downwards.
- g, g*, side flues.



foot less than the lower ; if cylindrical, the same as the lower. The height of the body from twelve to twenty feet. The draw door from eighteen inches to three feet. The height of the draw pit nine feet.

The body A of the masonry is sometimes rectangular and sometimes circular in plan, and about six feet in thickness. It is secured on the outside either by strips of wood let into the masonry, or by iron curbs. The lining of the kiln is of the best fire-brick.

The kiln, for burning, is filled with alternate layers of coal and stone, those of the latter not exceeding six inches in thickness. The fire is started from beneath, with dry wood. The drawing of the kiln is done two or three times every twenty-four hours.

75. The perpetual draw *water-flame* kilns, for both coal and wood, patented by Mr. C. D. Page, of Rochester, New York, have met with very general favor in our large lime burning localities.

The cupola which contains the burning lime, it will be seen, is chiefly cylindrical, being terminated at top and bottom by conical frusta.

The cupola space is six by eight feet between the main walls AA. The main walls from out to out are eighteen by twenty feet at the base of the kiln ; fifteen by sixteen feet at the top ; and forty feet high. The main walls are strengthened as usual with timber curbs. The wooden crib at top, which is strongly boarded to the height of four feet, serves as a reservoir for the raw stone.

This kiln receives its name from the coal being first placed in pans of hot water, the steam from which being decomposed facilitates the process of burning by the decomposition of the steam.

76. **Hoffman Kiln.** General Q. A. Gillmore, of the United States Corps of Engineers, to whom the profession is already so much indebted for his researches on the limes and cements in the United States, has given in his recent pamphlet, No. 19, *Professional Papers, Corps of Engineers, U. S. Army*, an account of what is known as the Hoffman Kiln, of which the following is a brief description :—

This kiln (Figs. 8, 9, 10, 11) consists of an annular arch, A, A', the plan of which may be a circle, an oval, or as in Fig. 8. The height of the arch being from eight to nine feet, and span from ten to twelve feet ; the middle line of the chamber A measuring one hundred and fifty feet. This void space is termed the *burning chamber*.

The chimney C, C' (Figs. 10, 11) may stand in the central space B, B', or exterior to the kiln. In the latter case a smoke flue leads to it under the burning chamber. Fourteen radial flues lead from the burning chambers to the smoke chamber,

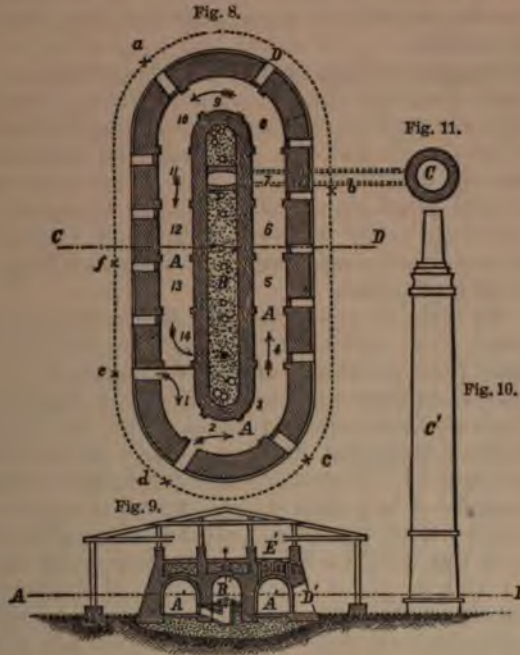

Fig. 8. Horizontal section of kiln on A B, Fig. 9.  
 Fig. 9. Vertical section on C D, Fig. 8.  
 Fig. 10. Elevation of chimney.  
 Fig. 11. Section of chimney at A B, Fig. 10.  
 A, A', Burning chamber.  
 B, B', Smoke chamber.  
 C, C, Chimney.  
 D, Doorways.  
 a, b, Lime-stone in process of burning.  
 b, c, do. do. of cooling.  
 c, d, do. do. of drawing.  
 d, e, do. do. of setting up.  
 e, f, do. do. of drying.  
 f a, do. do. of taking up waste heat.

each having a bell-shaped damper, which can be opened or closed at pleasure. There are fourteen arched doors, D, D, through the outer wall, each five feet high, and four feet wide.

The arched top of the burning chamber is pierced, at intervals of three or four feet, with holes, five inches in diameter, termed feed-holes, through which fuel is supplied to the fires.

They are in number about three hundred, each closed with a bell-shaped cover fitting over a rim or curb, and dipping into sand.

The entire structure is of solid stone or brick masonry, and covered with a roof.

The burning chamber is lined with fire-brick for burning hydraulic cement.

**77. Calcination of the stone.**—When the kiln is in operation all the doorways (Fig. 8) numbered from 1 to 14, from left to right are kept closed *with temporary brickwork*, except two or three. Let the open ones be 1 and 2. The burnt lime is drawn from No. 2, and raw stone taken in at No. 1 and piled up in the burning chamber, leaving vertical openings under the feed holes, and horizontal ones under the mass for the circulation of air around the periphery of the burning chamber.

When the kiln is going, all the compartments but two, between each two consecutive doorways, are filled with stone, in all stages, from the raw to thoroughly calcined.

“Suppose compartments 1 and 2 empty, and all the others filled. No. 3 contains cement from stone put in 12 days ago; No. 4 that from stone put in 11 days ago; and so on around to compartment 14, which was filled yesterday. Separating No. 14 from No. 1 is a sheet iron partition, as nearly as possible air-tight. This partition, called the *cut-off*, is movable. Yesterday it was between 13 and 14; to-morrow it will be between 1 and 2, and so on, being moved on one compartment each day. All the dampers are closed to-day except No. 14; yesterday all were closed except No. 13; to-morrow only No. 1 will be open. To-day men are removing burnt cement from compartment No. 2, and others are setting raw stone in compartment No. 1. Yesterday they were setting stone in No. 14, and removing cement from No. 1. To-morrow they will be removing cement from No. 3, and filling No. 2 with raw stone; so that every day the setting, drawing, cut-off, and open damper advance one compartment. The fires are in the centre of the mass, from the burnt cement end round to the raw stone end; say in compartments 7 and 8 to-day, 6 and 7 yesterday, 8 and 9 to-morrow, advancing one compartment per day, like the drawing and setting.

“The compartment that was in fire yesterday, say No. 6, is still very hot to-day, No. 5 less hot, No. 4 cooler, and so on to No. 2, where the cement is cool enough to be handled, and men are removing it from the kiln, wheelbarrows, or trucks on portable railway tracks, being used for the purpose.

"The compartments not yet fired are heated by the hot gases passing through them to the chimney, the stone in the compartment next the fire being at a full red heat, while that farthest off, which was put in yesterday, is only warm.

"The draught of the chimney is sufficient to draw air in at the open doorways, through the entire mass of cement and raw stone, to the open flue, which is the one by the cut-off.

"In passing through the burnt cement the air takes up the residue of heat and becomes hotter and hotter, till, after passing through the cement burned yesterday, the hot current ignites at once the dust coal as it falls from the feed pipes, and the gases thus formed being carried on, mixed with air, it is probable the stone is burned considerably in advance of where the coal is supplied.

"As the hot gases of combustion pass on, they give up their heat to the limestone, till, on arriving at the chimney, there is only heat enough remaining to cause a draught in a well-constructed chimney 140 to 150 feet in height. It is plain that *all* the heat of combustion is utilized, except such as may escape through the walls of the kiln, and as the masonry is very massive, the loss from this cause is very slight.

"One peculiar feature of these kilns is, that although less likely to get out of order than other kilns, from the fact that there is no movement in the burning mass, repairs may be easily made without letting the fire go down.

"There are Hoffman kilns in which the fires have not been extinguished for five years."

**78. Methods of reducing the calcined stone to powder.**—The calcined stone may be reduced to powder, either by a chemical or mechanical process. By the first, water combines with the lime, forming a hydrate of lime, which process is termed slaking. By the second the calcined stone is first broken into small lumps; these are then ground in a mill to the requisite degree of fineness, ascertained by the sieves through which the ground product must pass.

**79. Slaking.**—This may be done in three ways:

By pouring sufficient water on the burnt stone to convert the slaked lime into a thin paste, which is termed *drowning* the lime.

By placing the burnt stone in a basket, and immersing it for a few seconds in water, during which time it will imbibe enough water to cause it to fall, by slaking, into a dry powder; or by sprinkling the burnt stone with a sufficient quantity of water to produce the same effect.

By allowing the stone to slake spontaneously, from the

moisture it imbibes from the atmosphere, which is termed *air-slaking*.

80. Opinion seems to be settled among engineers, that drowning is the worst method of slaking lime which is to be used for mortars. When properly done, however, it produces a finer paste than either of the other methods; and it may therefore be resorted to whenever a paste of this character, or a whitewash is wanted. Some care, however, is requisite to produce this result. The stone should be fresh from the kiln, otherwise it is apt to slake into lumps or fine grit. All the water used should be poured over the stone at once, which should be arranged in a basin or vessel, so that the water surrounding it may be gradually imbibed as the slaking proceeds. If fresh water be added during the slaking, it checks the process, and causes a gritty paste to form.

81. In slaking by immersion, or by sprinkling with water, the stone should be reduced to small-sized fragments, otherwise the slaking will not proceed uniformly. The fat limes should be in lumps, about the size of a walnut, for immersion; and, when withdrawn from the water, should be placed immediately in bins, or be covered with sand, to confine the heat and vapour. If left exposed to the air, the lime becomes chilled and separates into a coarse grit, which takes some time to slake thoroughly when more water is added. Sprinkling the lime is a more convenient process than immersion, and is equally good. To effect the slaking in this way, the stone should be broken into fragments of a suitable size, which experiment will determine, and be placed in small heaps, surrounded by sufficient sand to cover them up when the slaking is nearly completed. The stone is then sprinkled with about one fourth its bulk of water, poured through the rose of a watering-pot, those lumps which seem to slake most sluggishly receiving the most water; when the process seems completed, the heap is carefully covered over with the sand, and allowed to remain a day or two before it is used.

82. Slaking either by immersion or by sprinkling is considered the best. The quantity of water imbibed by lime when slaked by immersion, varies with the nature of the lime; 100 parts of fat lime will take up only 18 parts of water; and the same quantity of meager lime will imbibe from 20 to 35 parts. One volume, in powder, of the burnt stone of rich lime yields from 1.50 to 1.70 in volume of powder of slaked lime, while one volume of meager lime, under like circumstances, will yield from 1.80 to 2.18 in volume of slaked lime.

83. Quick lime, when exposed to the free action of the air

in a dry locality, slakes slowly, by imbibing moisture from the atmosphere, with a slight disengagement of heat. Opinion seems to be divided with regard to the effect of this method of slaking on fat limes. Some assert, that the mortar made from them is better than that obtained from any other process, and attribute this result to the re-conversion of a portion of the slaked lime into a carbonate; others state the reverse to obtain, and assign the same cause for it. With regard to hydraulic limes, all agree that they are greatly injured by air-slaking.

84. When the slaking is imperfect and is owing as in most cases to the stone having been unequally burned, the lime should be reduced to a paste in a mortar mill that will grind fine all the lumps. This is particularly necessary in hydraulic limes, which are also improved in energy by this reduction of the underburned lumps.

85. Air-slaked fat limes increase two-fifths in weight, and for one volume of quick lime yield 3.52 volumes of slaked lime. The meager limes increase one-eighth in weight, and for one volume of quick lime yield from 1.75 to 2.25 volumes of slaked lime.

86. The dry hydrates of lime, when exposed to the atmosphere, gradually absorb carbonic acid and water. This process proceeds very slowly, and the slaked lime never regains all the carbonic acid which is driven off by the calcination of the lime-stone. When converted into a thick paste, and exposed to the air, the hydrates gradually absorb carbonic acid; this action first takes place on the surface, and proceeds more slowly from year to year towards the interior of the exposed mass. The absorption of gas proceeds more rapidly in the meager than in the fat limes. Those hydrates which are most thoroughly slaked become hardest. The hydrates of the pure fat limes become in time very hard, while those of the hydraulic limes become only moderately hard.

87. The fat limes, when slaked by drowning, may be preserved for a long period in the state of paste, if placed in a damp situation and kept from contact with the air. They may also be preserved for a long time without change, when slaked by immersion to a dry powder, if placed in covered vessels. Hydraulic limes, under similar circumstances, will harden if kept in the state of paste, and will deteriorate when a powder, unless kept in perfectly air-tight vessels.

88. The hydrates of fat lime, from air-slaking or immersion, require a smaller quantity of water to reduce them to the state of paste than the others; but, when immersed in water, they

gradually imbibe their full dose of water, the paste becoming thicker, but remaining unchanged in volume. Exposed in this way, the water will in time dissolve out all the lime of the hydrate which has not been reconverted into a sub-carbonate, by the absorption of carbonic acid before immersion; and if the water contain carbonic acid, it will also dissolve the carbonated portions.

89. The hydrates of hydraulic lime, when immersed in water in the state of thin pastes, reject a portion of the water from the paste, and become hard in time; if the paste be very stiff, they imbibe more water, set quickly, and acquire greater hardness in time than the soft pastes. The pastes of the hydrates of hydraulic lime, which have hardened in the air, will retain their hardness when placed in water.

90. All limes seem to have their hydraulic energy affected by the degree of their calcination; but only in their first stages of immersion. This is observed even in underburned common lime which, when suitably reduced, is found to be slightly hydraulic.

91. The pastes of the fat limes shrink very unequally in drying, and the shrinkage increases with the purity of the lime; on this account it is difficult to apply them alone to any building purposes, except in very thin layers. The pastes of the hydraulic limes can be used only with advantage under water, or where they are constantly exposed to humidity; and in these situations they are never used alone, as they are found to succeed as well, and to present more economy, when mixed with a portion of sand.

92. **Manner of reducing hydraulic cement.**—As the cement stones will not slake, they must be reduced to a fine powder by some mechanical process, before they can be converted into a hydrate. The methods usually employed for this purpose consist in first breaking the burnt stone into small fragments, either under iron cylinders, or in conical-shaped mills suitably formed for this purpose. The product is next ground between a pair of stones, or else crushed by an iron roller. The coarser particles are separated from the fine powder by the ordinary processes with sieves. The powder is then carefully packed in air-tight casks, and kept for use.

93. Hydraulic cement, like hydraulic lime, deteriorates by exposure to the air, and may in time lose all its hydraulic properties. On this account it should be used when fresh from the kiln; for, however carefully packed, it cannot be well preserved when transported to any distance.

94. The deterioration of hydraulic cements, from exposure

The air, arises, probably, from a chemical disunion between the constituent elements of the burnt stone, occasioned by the absorption of water and carbonic acid. When injured, their energy can be restored by submitting them to a much slighter degree of heat than that which is requisite to calcine the stone suitably in the first instance. From the experiments of M. Petot, it appears that a red heat, kept up for a short period, is sufficient to restore damaged hydraulic cements.

95. "As a rule, all hydraulic cements produced at a low heat, whether derived from argillaceous or argillo-magnesian lime-stones, are light in weight and quick-setting, and never attain, when made into mortar or béton, more than 30 to 33 per cent. of the strength and hardness of Portland cement placed in similar circumstances. They are also greatly inferior to good hydraulic lime. This is true of all cements made at a low heat, including even those derived from lime-stones, that might, with proper burning, have yielded Portland cement. The celebrated Roman cement, the twice-kilned artificial cements, the quick-setting French cement, like that of Vassy, and all the hydraulic cements manufactured at the present day in the United States, belong to this category."

**96. ARTIFICIAL HYDRAULIC LIMES AND CEMENTS.** The discovery of the argillaceous character of the stones which yield hydraulic limes and cements, connected with the fact that brick reduced to a fine powder, as well as several substances of volcanic origin having nearly the same constituent elements as ordinary brick, when mixed in suitable proportions with common lime, will yield a paste that hardens under water, has led, within a recent period, to artificial methods of producing compounds possessing the properties of natural hydraulic limestones.

97. M. Vicat was the first to point out the method of forming an artificial hydraulic lime, by mixing common lime and unburnt clay, in suitable proportions, and then calcining them. The experiments of M. Vicat have been repeated by several eminent engineers with complete success, and among others by General Pasley, who, in a recent work by him, *Observations on Limes, Calcareous Cements, etc.*, has given, with minute detail, the results of his experiments; from which it appears that an hydraulic cement, fully equal in quality to that obtained from natural stones, can be made by mixing common lime, either in the state of a carbonate or of a hydrate, with clay, and subjecting the mixture to a suitable de



gree of heat. In some parts of France, where chalk is found abundantly, the preparation of artificial hydraulic lime has become a branch of manufacture.

98. Different methods have been pursued in preparing this material, the main object being to secure the finest mechanical division of the two ingredients, and their thorough mixture. For this purpose the lime-stone, if soft, like chalk or tufa, may be reduced in a wash-mill, or a rolling-mill, to the state of a soft pulp; it is then incorporated with the clay, by passing them through a pug-mill. The mixture is next moulded into small blocks, or made up into balls between 2 and 3 inches diameter, by hand, and well dried. The balls are placed in a kiln,—suitably calcined, and are finally slaked, or ground down fine for use.

99. If the lime-stone be hard, it must be calcined and slaked in the usual manner, before it can be mixed with the clay. The process for mixing the ingredients, their calcination, and further preparation for use, are the same as in the preceding case.

100. The artificial hydraulic cement manufactured in France, at Boulogne, and possessing the same qualities as the artificial Portland cement, is composed of 79.5 per cent. of carbonate of lime in powder, and 20.5 of clay, which, after being thoroughly mixed, are subjected to a very high degree of temperature.

101. What is known, in commerce and among engineers, as artificial Portland cement, is a mixture of the blue clay of the London basin and chalk, formed by grinding the materials together in water. The semi-fluid mixture is run off into vats, and, after settling and attaining sufficient consistency, is dried by artificial heat and then calcined, at a high temperature, to the verge of vitrification. It is then reduced for use to a very fine powder. It is said not to deteriorate from exposure to the air, provided it be kept from moisture.

102. Artificial hydraulic lime, prepared from the hard limestones, is more expensive than that made from the soft; but it is stated to be superior in quality to the latter.

103. As clays are seldom free from carbonate of lime, and as the limestones which yield common or fat lime may contain some portion of clay, the proper proportions of the two ingredients, to produce either an hydraulic lime or a cement, must be determined by experiment in each case, guided by a previous analysis of the two ingredients to be tried.

If the lime be pure, and the clay be free from lime, then the combinations in the proportions given in the table of M

Petot will give, by calcination, like results with the same proportions when found naturally combined.

104. *Puzzolana, etc.* The practice of using brick or tile-dust, or a volcanic substance known by the name of *puzzolana*, mixed with common lime, to form an hydraulic lime, was known to the Romans, by whom mortars composed of these materials were extensively used in their hydraulic constructions. This practice has been more or less followed by modern engineers, who, until within a few years, either used the *puzzolana* of Italy, where it is obtained near Mount Vesuvius, in a pulverulent state, or a material termed *Trass*, manufactured in Holland, by grinding to a fine powder a volcanic stone obtained near Andernach, on the Rhine.

Experiments by several eminent chemists have extended the list of natural substances which, when properly burnt and reduced to powder, have the same properties as *puzzolana*. They mostly belong to the feldspathic and schistose rocks, and are either fine sand, or clays more or less indurated.

*The following Table gives the results of analyses of Puzzolana, Trass, a Basalt, and a Schistus, which, when burnt and powdered, were found to possess the properties of puzzolana.*

	Puzzolana.	Trass.	Basalt.	Schistus.
Silica.....	0.445	0.570	44.50	46.00
Alumina.....	0.150	0.120	16.75	26.00
Lime.....	0.088	0.026	9.50	4.00
Magnesia.....	0.047	0.010	—	—
Oxide of iron.....	0.120	0.050	20.00	14.00
Oxide of manganese.....	—	—	2.37	8.00
Potassa.....	0.014	0.070	—	—
Soda.....	0.030	0.010	2.60	—
Water and loss.....	0.106	0.144	4.28	2.00
	1.000	1.000	100.00	100.00

105. Whether natural *puzzolanas* occur in the United States, is not known. The great abundance of natural hydraulic cements would probably cause no demand for them, nor for artificial *puzzolanas* for building purposes.

106. All of these substances, when prepared artificially, are now generally known by the name of *artificial puzzolanas*, in contradistinction to those which occur naturally.

107. General Treussart, of the French Corps of Military Engineers, first attempted a systematic investigation of the

properties of artificial puzzolanas made from ordinary clay and of the best manner of preparing them on a large scale. It appears from the results of his experiments, that the plastic clays used for tiles, or pottery, which are unctuous to the touch, the alumina in them being in the proportion of one fifth to one third of the silica, furnish the best artificial puzzolanas when suitably burned. The clays which are more meager, and harsher to the touch, yield an inferior article, but are in some cases preferable, from the greater ease with which they can be reduced to a powder.

108. As the clays mostly contain lime, magnesia, some of the metallic oxides, and alkaline salts, General Treussart endeavored to ascertain the influence of these substances upon the qualities of the artificial puzzolanas from clays in which they are found. He states, that the carbonate of potash and the muriate of soda seem to act beneficially; that magnesia seems to be passive, as well as the oxide of iron, except when the latter is found in a large proportion, when it acts hurtfully; and that the lime has a material influence on the degree of heat required to convert the clay into a good artificial puzzolana.

109. The management of the heat, in the preparation of this material, seems of the first consequence; and General Treussart recommends that direct experiment be resorted to, as the most certain means of ascertaining the proper point. For this purpose, specimens of the clay to be tried may be kneaded into balls as large as an egg, and the balls when dry, be submitted to different degrees of heat in a kiln, or furnace, through which a current of air must pass over the balls, as this last circumstance is essential to secure a material possessing the best hydraulic qualities. Some of the balls are withdrawn as soon as their color indicates that they are underburnt; others when they have the appearance of well-burnt brick; and others when their color shows that they are overburnt, but before they become vitrified. The burnt balls are reduced to an impalpable powder, and this is mixed with a hydrate of fat lime, in the proportion of two parts of the powder to one of lime in paste. Water is added, if necessary, to bring the different mixtures to the consistence of a thick pulp; and they are separately placed in glass vessels, covered with water, and allowed to remain until they harden. The compound which hardens most promptly will indicate the most suitable degree of heat to be applied.

110. As the carbonates of lime, of potash, and of soda, act as fluxes on silica, the presence of any one of them will

modify the degree of heat necessary to convert the clay into a good natural puzzolana. Clay, containing about one tenth of lime, should be brought to about the state of slightly-burnt brick. The ochreous clays require a higher degree of heat to convert them into a good material, and should be burnt until they assume the appearance of well-burnt brick. The more refractory clays will bear a still higher degree of heat; but the calcination should in no case be carried to the point of incipient vitrification.

111. The quantity of lime contained in the clay can be readily ascertained beforehand, by treating a small portion of the clay, diffused in water, with enough muriatic acid to dissolve out the lime; and this last might serve as a guide in the preliminary stages of the experiments.

112. General Treussart states, as the results of his experiments, that the mixture of artificial puzzolana and fat lime forms an hydraulic paste superior in quality to that obtained by M. Vicat's process for making artificial hydraulic lime. M. Curtois, a French civil engineer, in a memoir on these artificial compounds, published in the *Annales des Ponts et Chaussées*, 1834, and General Pasley, more recently, adopt the conclusion of General Treussart. M. Vicat's process appears best adapted when chalk, or any very soft lime-stone, which can be readily converted to a soft pulp, is used, as offering more economy, and affording an hydraulic lime which is sufficiently strong for most building purposes. By it General Pasley has succeeded in obtaining an artificial hydraulic cement which is but little, if at all, inferior to the best natural varieties; a result which has not been obtained from any combination of fat lime with puzzolana, whether natural or artificial.

113. All the puzzolanas possess the important property of not deteriorating by exposure to the air, which is not the case with any of the hydraulic limes or cements. This property may render them very serviceable in many localities, where only common or feebly hydraulic lime can be obtained.

114. The well-known artificial Portland cement, manufactured in England, is composed of an intimate mixture of chalk and clay, in the state of paste, which is then dried and burned in kilns or ovens; the product of the calcination being flinty, or like vitrified brick. This degree of calcination is essential to the excellence of the material, of which its weight, or specific gravity, is one of the best tests.

Another more recent method of giving a certain degree of hydraulicity to common limes, and of improving that of hy-

draulic limes, is to place the calcined stone, after it has been drawn from the kiln, in arched ovens which can be made airtight, in which it can be subjected to the action of a fire, from a grate beneath; so that the heat can be equally diffused throughout the mass, which is brought only to a slight glow, as seen by the eye. When in this condition, iron pots containing sulphur are placed underneath, and the sulphur, converted into vapour, allowed to permeate the mass of lime; the escape of the vapour from the oven having been previously provided against. After the sulphur has been consumed the mass is allowed to cool, and is then ground fine like other cements. This product is known in commerce as *Scott's cement*, from the name of the inventor, an officer of the Royal Engineers. See *Professional Papers of the Corps of Royal Engineers* Vol. X. New Series.

---

#### IV.

##### MORTAR.

115. *Mortar* is any mixture of lime in paste with sand. It may be divided into two principal classes; *Hydraulic mortar*, which is made of hydraulic lime, and *Common mortar*, made of common lime.

116. The term *Grout* is applied to any mortar in a thin or fluid state; and the terms *Concrete* and *Beton*, to mortars incorporated with gravel and small fragments of stone or brick.

117. Mortar is used for various purposes in building. It serves as a cement to unite blocks of stone, or brick. In concrete and beton, which may be regarded as *artificial conglomerate stones*, it forms the *matrix* by which the gravel and broken stone are held together; and it is the principal material with which the exterior surfaces of walls and the interior of edifices are coated.

118. The quality of mortars, whether used for structures exposed to the weather, or for those immersed in water, will depend upon the nature of the materials used; their proportions; the manner in which the lime has been converted into a paste to receive the sand; and the mode employed to mix the ingredients. Upon all of these points experiment

is the only unerring guide for the engineer; for the great diversity in the constituent elements of limestones, as well as in the other ingredients of mortars, must necessarily alone give rise to diversities in results; and when, to these causes of variation, are superadded those resulting from different processes pursued in the manipulations of slaking the lime and mixing the ingredients, no surprise should be felt at the seemingly opposite conclusions at which writers, who have pursued the subject experimentally, have arrived. From the great mass of facts, however, presented on this subject within a few years, some general rules may be laid down, which the engineer may safely follow, in the absence of the means of making direct experiments.

119. As to the action of salt water on artificial hydraulic limes made by mixing common lime with a natural or artificial puzzolana, opinion among European engineers seems divided. Some state that they withstand well the action of salt water; others that they resist this action only after the exposed surface becomes coated with barnacles, oysters, etc.

120. The view now generally taken of mortar is, that being an artificial sandstone, the nearer its constituents approach those of the natural sandstones, the better will be the result obtained; and that therefore the best proportions for its ingredients are those in which each grain of sand is enveloped with just sufficient lime, in a barely moist state, to cause the whole mass to cohere and set quickly. Too much lime causes shrinkage and cracks; and when too much water is added the mass in drying is found to be porous.

121. *Sand.* This material, which forms one of the ingredients of mortar, is the granular product arising from the disintegration of rocks. It may, therefore, like the rocks from which it is derived, be divided into three principal varieties—the silicious, the calcareous, and the argillaceous.

Sand is also named from the locality where it is obtained, as *pit sand*, which is procured from excavations in alluvial, or other deposits of disintegrated rock; *river sand*, and *sea sand*, which are taken from the shores of the sea, or rivers.

Builders again classify sand according to the size of the grain. The term *coarse sand* is applied when the grain varies between  $\frac{1}{8}$ th and  $\frac{1}{4}$ th of an inch in diameter; the term *fine sand*, when the grain is between  $\frac{1}{16}$ th and  $\frac{1}{4}$ th of an inch in diameter; and the term *mixed sand* is used for any mixture of the two preceding kinds.

122. The silicious sands, arising from the quartzose rocks, are the most abundant, and are usually preferred by builders.

The calcareous sands, from hard calcareous rocks, are more rare, but form a good ingredient for mortar. Some of the argillaceous sands possess the properties of the less energetic puzzolanas, and are therefore very valuable, as forming with common lime an artificial hydraulic lime.

123. The property which some argillaceous sands possess, of forming with common, or slightly hydraulic lime a compound which will harden under water, has been long known in France, where these sands are termed *arènes*. The sands of this nature are usually found in hillocks along river valleys. These hillocks sometimes rest on calcareous rocks, or argillaceous tufas, and are frequently formed of alternate beds of the sand and pebbles. The sand is of various colors, such as yellow, red, and green, and seems to have been formed from the disintegration of clay in a more or less indurated state. The *arènes* are not as energetic as either natural or artificial puzzolanas; still they form, with common lime, an excellent mortar for masonry exposed either to the open air, or to humid localities, as the foundations of edifices.

124. Pit-sand has a rougher and more angular grain than river or sea sand; and, on this account, is generally preferred by builders for mortars used for brick, or stone-work. Whether it forms a stronger mortar than the other two is not positively settled, although some experiments would lead to the conclusion that it does.

125. River and sea sand are by some preferred for plastering, because they are whiter, and have a finer and more uniform grain than pit sand; but as the sands from the shores of tidal waters contain salts, they should not be used, owing to their hygrometric properties, before the salts are dissolved out in fresh water by careful washing.

126. Pit sand is seldom obtained free from a mixture of dirt, or clay; and these, when found in any notable quantity in it, give a weak and bad mortar. Earthy sands should, therefore, be cleansed from dirt before using them for mortar; this may be effected by washing the sand in shallow vats, and allowing the turbid water, in which the clay, dust and other like impurities are held in suspension, to run off.

127. Sand, when pure or well cleansed, may be known by not soiling the fingers when rubbed between them.

128. **Hydraulic mortar.** This material may be made from the natural hydraulic limes; from those which are prepared by M. Vicat's process; or from a mixture of common or feebly hydraulic lime with a natural or artificial puzzolana. All writers, however, agree that it is better to use a natura-

than an artificial hydraulic lime, when the former can be readily procured.

129. When the lime used is strongly hydraulic, M. Vicat is of opinion that sand alone should be used with it, to form a good hydraulic mortar. General Treussart has drawn the conclusion, from his experiments, that the mortar of all hydraulic limes is improved by an addition of a natural or artificial puzzolana. The quantity of sand used may vary from  $1\frac{1}{4}$  to 2 parts of the lime in bulk, when reduced to a thick pulp.

130. The practice of the United States Corps of Engineers, in the construction of heavy masonry, has been to add from 2.5 to 3.5, in bulk, of compact sand to one of lime of a thick paste in the composition of their hydraulic mortars; and it has been found that an equal bulk of common lime in paste can be mixed with hydraulic cement paste without occasioning any material diminution in the strength of the resulting mortar.

131. For hydraulic mortars, made of common, feeble, or ordinary hydraulic limes, and artificial puzzolana, M. Vicat states that the puzzolana should be the weaker as the lime is more strongly hydraulic; using, for example, a very energetic puzzolana with a fat or a feebly hydraulic lime. The proportion of sand which can be incorporated with these ingredients, to form an hydraulic mortar, is stated by General Treussart to be one volume to one of puzzolana, and one of lime in paste.

132. In proportioning the ingredients, the object to which the mortar is to be applied should be regarded. When it is to serve to unite stone, or brick work, it is better that the hydraulic lime should be rather in excess: when it is used as a *matrix* for beton, no more lime should be used than is strictly required. No harm will arise from an excess of good hydraulic lime, in any case; but an excess of common lime is injurious to the quality of the mortar.

133. Common and ordinary hydraulic limes, when made into mortar with *arènes*, give a good material for hydraulic purposes. The proportions in which these have been found to succeed well, are one of lime to three of *arènes*.

134. Hydraulic cement, from the promptitude with which it hardens, both in the air and under water, is an invaluable material where this property is essential. Any dose of sand injures its properties as a cement. But hydraulic cement may be added with decided advantage to a mortar of common, or of feebly hydraulic lime and sand. It is in this



way that it is generally used in our public works. The French engineers give the preference to a good hydraulic mortar over hydraulic cement, both for uniting stone, or brick work, and for plastering. They find, from their practice, that when used as a stucco, it does not withstand well the effects of weather; that it swells and cracks in time; and, when laid on in successive coats, that they become detached from each other.

General Pasley, who has paid great attention to the properties of natural and artificial hydraulic cements, does not agree with the French engineers in his conclusions. He states that, when skilfully applied, hydraulic cement is superior to any hydraulic mortar for masonry, but that it must be used only in thin joints, and when applied as a stucco, that it should be laid on in but one coat; or, if it be laid on in two, the second must be added long before the first has set, so that, in fact, the two make but one coat. By attending to these precautions, General Pasley states that a stucco of hydraulic cement and sand will withstand perfectly the effects of frost.

**135. Mortars exposed to weather.**—The French engineers, who have paid great attention to the subject of mortars, coincide in the opinion, that a mortar cannot be made of fat lime and any inert sands, like those of the silicious, or calcareous kinds, which will withstand the ordinary exposure of weather; and that, to obtain a good mortar for this purpose, either the hydraulic limes mixed with sand must be employed, or else common lime mixed either with *arènes*, or with a puzzolana and sand.

**136.** Any pure sand, mixed in proper proportions with hydraulic lime, will give a good mortar for the open air; but the hardness of the mortar will be affected by the size of the grain, particularly when hydraulic lime is used. Fine sand yields the best mortar with good hydraulic lime; mixed sand with the feebly hydraulic limes; and coarse sand with fat lime.

**137.** For mortar to be used for filling the exterior of the joints, or as it is termed, for pointing, the amount of lime paste in bulk should be but slightly greater than that of the void spaces of grains of sand. The bulk of sand for this purpose should be from 2.5 to 2.75 that of the lime paste.

**138.** The proportion which the lime should bear to the sand seems to depend, in some measure, on the manner in which the lime is slaked. M. Vicat states, that the strength of mortar made of a stiff paste of fat lime, slaked in the ordinary way, increases from 0.50 to 2.40 to one of the paste in

volume; and that, when the lime is slaked by immersion, one volume of the like paste will give a mortar that increases in strength from 0.50 to 2.20 parts of sand.

For one volume of a paste of hydraulic lime, slaked in the ordinary way, the strength of the mortar increases from 0 to 1.80 parts of sand; and, when slaked by immersion, the mortar of a like paste increases in strength from 0 to 1.70 parts of sand. In every case, when the dose of sand was increased beyond these proportions, the strength of the resulting mortar was found to decrease.

**139. Manipulations of mortar.**—The quality of hydraulic mortar, which is to be immersed in water, is more affected by the manner in which the lime is slaked, and the ingredients mixed, than that of mortar which is to be exposed to the weather; although in both cases the increase of strength, by the best manipulations, is sufficient to make a study of them a matter of some consequence.

**140.** The results obtained from the ordinary method of slaking, by sprinkling, or by immersion, in the case of good hydraulic limes, are nearly the same. Spontaneous, or air-slaking, gives invariably the worst results. For common and slightly hydraulic lime, M. Vicat states that air-slaking yields the best results, and ordinary slaking the worst.

**141.** The ingredients of mortar are incorporated either by manual labor, or by machinery: the latter method gives results superior to the former. The machines commonly used for mixing mortar are either the ordinary pug-mill (Fig. 12) employed by brickmakers for tempering clay, or a grinding-mill (Fig. 13). The grinding-mill is the best machine, because it not only reduces the lumps, which are found in the most carefully burnt stone, after the slaking is apparently complete, but it brings the lime to the state of a uniform stiff paste, which it should receive before the sand is incorporated with it. The same should be done with respect to the addition of cement, or of an alkaline silicate to the lime paste, the former in powder, and the latter in solution, being uniformly sprinkled over the surface and then thoroughly incorporated with the other materials by the action of the mill. Care should be taken not to add too much water, particularly when the mortar is to be immersed in water. The mortar-mill, on this account, should be sheltered from rain; and the quantity of water with which it is supplied may vary with the state of the weather. Nothing seems to be gained by carrying the process of mixing beyond obtaining a uniform mass of the consistence of plastic clay. Mortars of hydraulic lime are injured by long expo-

sure to the air, and frequent turnings and mixings with a shovel or spade; those of common lime, under like circum-

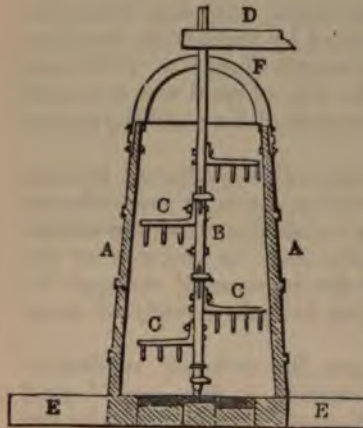

Fig. 12 represents a vertical section through the axis of a pug-mill, for mixing or tempering mortar.—This mill consists of a hooped vessel, of the form of a conical frustum, which receives the ingredients, and a vertical shaft, to which arms with teeth, resembling an ordinary rake, are attached, for the purpose of mixing the ingredients.

- A, A, section of sides of the vessel.
- B, vertical shaft to which the arms C are affixed.
- D, horizontal bar for giving a circular motion to the shaft B.
- E, sills of timber supporting the mill.
- B, wrought-iron support through which the upper part of the shaft passes.

stances seem to be improved. Mortar which has been set aside for a day or two, will become sensibly firmer; if not

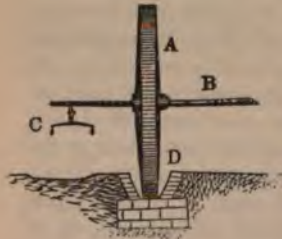

Fig. 13 represents a part of a mill for crushing the lime and tempering the mortar.

- A, heavy wheel of timber, or cast iron.
- B, horizontal bar passing through the wheel, which at one extremity is fixed to a vertical shaft, and is arranged at the other (C) with the proper gearing for a horse.
- D, a circular trough, with a trapezoidal cross section which receives the ingredients to be mixed. The trough may be from 20 to 30 feet in diameter; about 18 inches wide at top, and 12 inches deep; and be built of hard brick, stone, or timber laid on a firm foundation.

allowed to stand too long, it may be again reduced to its clayey consistence, by simply pounding it with a beetle, without any fresh addition of water.

**Fort Warren Mortar Mill.**—This mill (Fig. 14) which was used by Col. Thayer in the construction of Fort Warren, Boston Harbor, consists of a circular trough, which was fifteen feet in diameter, measured between the centre line of the trough, the cross section of which (A) was thirty-three inches in width at the top, thirteen inches at the

bottom, and twenty-four inches deep. The brick side-walls (A) twelve inches thick at top, and built vertically on the interior and outside, rested on an annular trench of concrete,

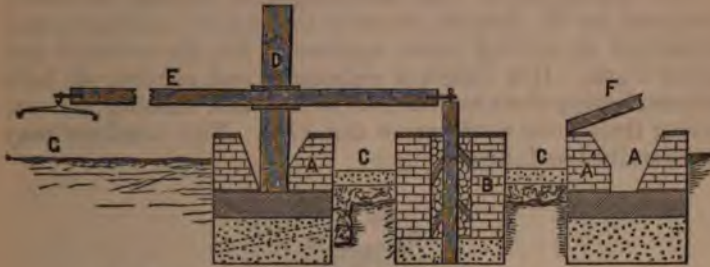

Fig. 14. Section through the axis of the Fort Warren Mortar Mill.

- A, Annular trough for mixing the mortar.
- A, Brick sides of trough.
- B, Central brick cylinder.
- C, Annular space for holding lime in paste.
- D, Wheel of mill.
- E, Shaft worked by horse power.
- F, Wooden trough for conveying lime paste to C.
- G, Horse track.

one foot thick, which was laid on an annular bed of broken stone, two feet thick, for drainage.

In the centre of the circle enclosed by the trough, a vertical post, surrounded with broken stone, encased by a brick cylinder (B) has a gudgeon at top, around which the horizontal shaft (E) turns, that gives motion to the wheel (D) for mixing the mortar.

The wheel (D) is made of wood on the sides and periphery, and has an iron tire twelve inches broad and half an inch thick; the interior being filled with sand to give it sufficient weight to grind any lumps in the lime to a paste. The diameter of the wheel is eight feet, and thickness eight inches.

The radius of the horse track for working the wheel is twenty feet.

The annular space between the trough and the brick cylinder in the centre is floored with concrete, resting on a bed of broken stone.

Lieut. W. H. Wright, in his *Treatise on Mortars*, thus describes the use made of this annular ring: "The space between the cylinder and trough is used as a reservoir for the slaked lime. It is conveniently divided by means of movable radial partitions into sixteen equal parts," each containing the sixteenth part of a cask of lime in paste.

A wooden trough (F) leads from the reservoir where the

lime is slaked and converted into a creamy consistence, to the annular ring (C), where it is allowed to stand as long as possible before being thrown, with the requisite quantity of sand, into the mill.

**The malaxator.**—Many advantages are claimed for a mill designed by M. Coignet, recently introduced in France, and employed in mixing *béton aggloméré* for the works in and about Paris. It is called a malaxator, and consists of twin screws, having their helices interlocked, and turning and exerting their force in the same direction. This machine may be described as follows :

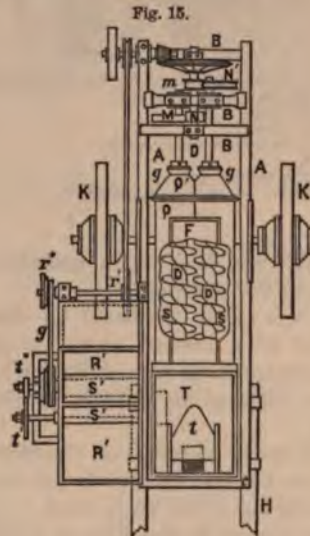

A is the frame of the machine, having at the upper end the cross-pieces B, upon which are mounted the gearings, and at the lower part the cross-piece *cc'*, upon which are fixed the rests or steps for the lower part of the helices to run in.

D are the cores of the helices, upon which are fastened either continuous or interrupted blades S S S, forming the thread of the helix. Continuous blades are more generally used.

K are wagon-wheels, mounted on an axle, which enable the machine to be transported thereon, and which, when the machine is in use, serve to maintain the malaxator at its proper

inclination (about twenty-five degrees). The brace J is used to steady the malaxator.

M N *m* N', gearings of any kind for giving motion to the helices, either by steam, horse-power, or hand-power; *g*, conical sleeves or stoppers, adjustable upon the shafts D, for regulating the exodus of the artificial stone paste, and by retarding the same, increasing the pressure and malaxation of the paste in the part Q' of the machine.

Q, body of the malaxator, corresponding in shape and size to the helices.

P, receiving chamber, where the materials enter the malaxator.

T, sand hopper, with its adjustable register or gate *t*, and, when required, a sifting apparatus; *q'*, sliding gate, to allow of the drainage of the machine.

S' S', feeding screws, working in the lower part of the two hoppers R' R', the one for lime, the other for sand, or any other material or substance to be introduced into the artificial stone paste, and feeding the same to the chamber P; *r r' r'' r'''*, pulleys, for chains or belts *g*, for transmitting the movement to the feeding screws S' S'; *t' t''*, spur-wheel and pinion (changeable for others of different relative speed), for regulating the exact amount of the two substances in the hoppers R' R', to be delivered, in so many turns of the helices, into the receiving chamber P.

Z is a pipe for supplying the water, for which there is an overflow at W. The sand being drowned or fully saturated in a given proportion, by varying the overflow W, gives the proper amount of water for each turn of the helices.

H are movable wooden shafts, which are placed in proper straps in the machine, and serve to hitch or harness a horse to the same when it has to be taken from one place to another, making it a perfect wagon.

The advantages claimed for the malaxator are the following:

First. The apparatus, having the receiving chamber P upon the ground, is fed easily, with little labor; and the part Q', or delivery, being elevated, allows of a wheelbarrow or basket being placed under to receive the artificial stone paste. This inclination also causes a more powerful malaxation, by retarding the progress of the matter, owing to the specific gravity.

Second. The gearings are out of the way, away from sand, water, dust, etc.

Third. The helices having their blades interlaid, their action upon the materials is of quite a different character than when said helices are not thus conjugated.

Fourth. The sand is gauged by a register. The lime and the hydraulic cement, the coloring matter, texture giver, or any other material used, may be also fed automatically, and the machine once set by the inspector, the product is invariably the same, besides saving the labor of a hand whose trustworthiness is required to obtain good results. The continuous introduction by small and regular quantities of the different

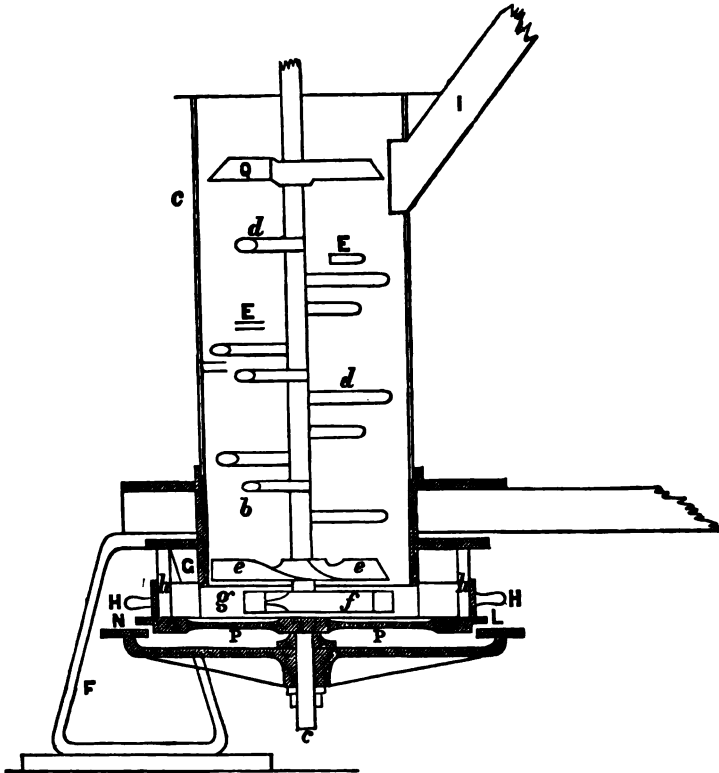

Fig. 16 represents a vertical section of the mixing cylinder for beton coignet.  
 a, side of cylinder.  
 b, cast iron base.  
 c, vertical shaft.  
 d, d, curved arms.  
 e, e, helicoidal blades.  
 f, f, cycloidal arms.  
 g, horizontal opening at the base.

A, A, vertical guides for movable band.  
 E, E, short stationary arms.  
 G, G, movable band.  
 H, H, handles for lifting band.  
 I, supply trough.  
 L, scraper.  
 N, revolving horizontal plate.  
 P, immovable bottom plate.

substances, and the constant amount of the water supplied to the sand, place the materials in the best circumstances for producing, by proper action of the helices, an excellent result,

difficult to obtain if the component ingredients had been thrown in by shovel or basketfuls at a time. (See *Professional Papers, Corps of Engineers*, No. 19).

Another form of mill, which is shown in Fig. 16, has been made use of in France for mixing certain kinds of beton. It consists of a vertical cylinder *a* resting on a cylindrical base of cast iron *b*. A vertical shaft *c* passes through the cylinder, having attached to it curved arms *d*, which, by revolving horizontally, serve to mix the sand and lime. The distributor *Q* revolves horizontally, receives the sand and lime which come from the conducting trough *I*, and distributes them equally around for mixing. Short stationary arms *E E* are attached to the side of the cylinder, and form, with the movable arms, breaks for dashing and mixing the sand and lime. Three helicoidal blades *e e*, attached to the lower part of the shaft, force the mixture downwards and outwards. Cycloidal arms *f f*, revolving horizontally near the floor of the cylinder, expel the mixture at the side opening around the bottom. A movable band of iron *G G*, by being moved up or down, enlarges or diminishes the opening around the bottom. *h h*, vertical guiding shafts for movable band. *H H*, handles by which the band *G G* is moved. A plate *N* is attached to *c* and revolves horizontally, receiving the mixture from the cylinder. A curved plate of iron *L*, fixed to immovable bottom-plate *P*, scrapes mixture from *N* as it revolves.

**143. Setting and durability of mortars.** Mortar of common lime, without any addition of puzzolana, will not set in humid situations, like the foundations of edifices, until after a very long lapse of time. They set very soon when exposed to the air, or to an atmosphere of carbonic acid gas. If, after having become hard in the open air, they are placed under water, they in time lose their cohesion and fall to pieces.

**144.** Common mortars, which have had time to harden, resist the action of severe frosts very well, if they are made rather *poor*, or with an excess of sand. The sand should be over 2.40 parts, in bulk, to one volume of the lime in paste; and coarse sand is found to give better results than fine sand.

**145.** Good hydraulic mortars set equally well in damp situations, and in the open air; and those which have hardened in the air will retain their hardness when immersed in water. They also resist well the action of frost, if they have had time to set before exposure to it; but, like common mortars, they require to be made with an excess of sand, to withstand well atmospheric changes.

**146.** The surface of a mass of hydraulic mortar, whether



made of a natural hydraulic lime or otherwise, when immersed in water, becomes more or less degraded by the action of the water upon the lime, particularly in a current. When the water is stagnant, a very thin crust of carbonate of lime forms on the surface of the mass, owing to the absorption by the lime of the carbonic acid gas in the water. This crust, if the water be not agitated, will preserve the soft mortar beneath it from the farther action of the water, until it has had time to become hard, when the water will no longer act upon the lime in any perceptible degree.

147. Hydraulic mortars set with more or less promptness, according to the character of the hydraulic lime, or of the puzzolana which enters into their composition. Artificial hydraulic mortars, with an excess of lime, set more slowly than when the lime is in a just proportion to the other ingredients.

148. The quick-setting hydraulic limes are said to furnish a mortar which, in time, acquires neither as much strength nor hardness as that from the slower-setting hydraulic limes. Artificial hydraulic mortars, on the contrary, which set quickly gain, in time, more strength and hardness than those which set slowly.

149. The time in which hydraulic mortars, immersed in water, attain their greatest hardness, is not well ascertained. Mortars made of strong hydraulic limes do not show any appreciable increase of hardness after the second year of their immersion; while the best artificial hydraulic mortars continue to harden, in a sensible degree, during the third year after their immersion.

150. It is found from experience that those mortars which attain the highest degree of hardness on the surface, absorb the least amount of water and are less liable to injury from frost and weather.

151. **Theory of Mortars.** The paste of a hydrate, either of common or of hydraulic lime, when exposed to the air, absorbs carbonic acid gas from it; passes to the state of sub-carbonate of lime; without, however, rejecting the water of the hydrate, and gradually hardens. The time required for the complete saturation of the mass exposed, will depend on its bulk. The absorption of the gas commences at the surface and proceeds more slowly towards the centre. The hardening of mortars exposed to the atmosphere is generally attributed to this absorption of the gas, as no chemical action of lime upon quartzose sand, which is the usual kind employed for mortars, has hitherto been detected by the most careful experiments.

The depth to which the absorption of carbonic acid extends in hydraulic lime, and also in some degree the hardening, decreases as the hydraulic energy caused by the silica that enters into their composition is the greater.

152. With regard to hydraulic mortars, it is difficult to account for their hardening, except upon the effect which the silicate of lime may have upon the excess of simple hydrate of uncombined lime contained in the mass. M. Petot supposes, that the particles of silicate of lime form so many centres, around which the uncombined hydrates group themselves in a crystalline form; becoming thus sufficiently hard to resist the solvent action of water. With respect to the action of quartzose sand in hydraulic mortars, M. Petot thinks that the grains produce the same mechanical effect as the particles of the silicate of lime, in inducing the aggregation of the uncombined hydrate.

---

## V.

### CONCRETE. BETON.

153. This term is applied, by English architects and engineers, to a mortar of finely-pulverized quick-lime, sand, and gravel. These materials are first thoroughly mixed in a dry state, sufficient water is added to bring the mass to the ordinary consistence of mortar, and it is then rapidly worked up by a shovel, or else passed through a pug-mill. The concrete is used immediately after the materials are well incorporated, and while the mass is hot.

154. The materials for concrete are compounded in various proportions. The most approved are those in which the lime and sand are in the proper proportions to form a good mortar, and the gravel is twice the bulk of the sand. The gravel used should be clean, and any pebbles contained in it larger than an egg, should be broken up before the materials are incorporated.

155. Hot water has in some cases been used in making concrete. It causes the mass to set more rapidly, but is not otherwise of any advantage.

156. The bulk of a mass of concrete, when first made, is found to be about one-fifth less than the total bulk of the dry materials. But, as the lime slakes, the mass of concrete is found to expand about three-eighths of an inch in height, for every foot of the mass in depth.

157. The use of concrete is at present mostly restricted to forming a solid bed, in bad soils, for the foundations of edifices. It has also been used to form blocks of artificial stone, for the walls of buildings and other like purposes; but experience has shown that it possesses neither the durability nor strength requisite for structures of a permanent character, when exposed to the action of water, or of the weather.

158. **BETON.** The term *béton* is applied, by French engineers, to any mixture of hydraulic mortar with fragments of brick, stone, or gravel; and it is now also used by English engineers in the same sense.

159. The proportions of the ingredients used for *béton* are variously stated by different authors. The sole object for which the gravel, or the broken stone is used, being to obtain a more economical material than a like mass of hydraulic mortar alone would yield, the quantity of broken stone should be as great as can be thoroughly united by the mortar. The smallest amount of mortar, therefore, that can be used for this purpose, will be that which will be just equal in volume to the void spaces in any given bulk of the broken stone, or gravel. The proportion which the volume occupied by the void spaces bears to any bulk of a loose material, like broken stone, or gravel, may be readily ascertained by filling a vessel of known capacity with the loose material, and pouring in as much water as the vessel will contain. The volume of water thus found, will be the same as that of the void spaces.

*Béton* made of mortar and broken stone, in which the proportions of the ingredients were ascertained by the process just detailed, has been found to give satisfactory results; but, in order to obviate any defect arising from imperfect manipulation, it is usual to add an excess of mortar above that of the void spaces.

160. In a large amount of concrete used for the foundation bed and backing of the sea walls built for the protection of the islands in Boston Harbor, which was composed of hydraulic mortar made with salt water and the common shingle of the shores, which varied in size from that of a pea to pebbles of six inches in diameter, the proportions used for the foundation bed was about one part in volume of stiff mortar to three

parts in volume of shingle for the foundation bed, and two and seven-tenths parts for the backing of the walls. The small and large pebbles of the shingle were so proportioned as to give the least amount of void space to be filled by the mortar; this void space being from twenty to twenty-five per cent. of the volume of shingle.

The materials were mixed by hand; the shingle first being spread out upon a platform of rough boards to the depth of from eight to twelve inches, the larger pebbles on top; the mortar was spread in a layer of uniform thickness over this, and the whole worked up with shovels and hoes until thoroughly incorporated.—(Papers on Practical Engineering, No. 2. Report of Col. S. Thayer, U. S. Corps of Engineers.)

In the hydraulic concrete used upon some others of our public works, the broken fragments of granite were in bulk about  $1\frac{1}{2}$  that of the hydraulic mortar. Besides this, other fragments, from a quarter to three-quarters of a cubic foot each, and forming about one-twelfth of the volume of the concrete, were worked into the layer as they were carried up. This practice is a very usual one for foundation beds, as it effects a saving of cost.

The best and most economical *béton* is made of a mixture of broken stone, or brick, in fragments not larger than a hen's egg, and of coarse and fine gravel mixed in suitable proportions.

In making *béton*, the mortar is first prepared, and then incorporated with the finer gravel; the resulting mixture is spread out into a cake, 4 or 6 inches in thickness, over which the coarser gravel and broken stone are uniformly strewed and pressed down, the whole mass being finally brought to a homogeneous state with the hoe and shovel.

*Béton* is used for the same purposes as concrete, to which it is superior in every respect, but particularly so for foundations laid under water, or in humid localities.

161. *Béton* made of small fragments of stone or pebbles has within recent years been applied to the construction of the walls of houses. For this purpose, the concrete is laid up in layers and rammed within a plank boxing having an interior width equal to the thickness of wall. The sides of the boxing are confined by vertical posts which can be suitably adjusted to the required thickness of the wall; the whole being supported by a suitable scaffolding. In the case of hollow walls, a slip of board of the thickness of the required hollow, or void, and slightly wedge-shaped to admit of its being easily removed, is laid horizontally within the box, and the layer of

concrete rammed well in around it; ordinary brick being inserted as ties to connect the interior and exterior portions of the wall.

In the sewers and many public and private edifices recently constructed in Paris of concrete, the proportions used were one part in volume of lime, one fourth of one volume of hydraulic cement, to five volumes of sand. It is stated that in six or eight hours after beginning a given length of sewer the centres can be safely removed; and that, in four or five days after a section has been completed, it can be opened for use. For the construction of arches, the volume of cement used is doubled.

Some of the buildings above referred to were constructed with groined or cylindrical arched fire-proof floors, of spans from nine to twenty-eight feet, the rise in each case being one tenth of the span; the thickness of the arches, at the crown, varying from five and a half to fourteen inches.

The crushing weight of this concrete is nearly fifty-four hundred pounds to the square inch; the tenacity about five hundred pounds.

162. An artificial sandstone, termed *Béton-Coignet* from the inventor, is very extensively manufactured and used in France for all building purposes, as foundations, walls, light arches, etc. It sets and hardens in a comparatively short time. Its constituents are clean river sand from four to five parts in volume; common or hydraulic lime one part in volume; hydraulic or artificial Portland cement from one-quarter to three-quarters of one part in volume; water variable, but only enough to moisten the other materials and cause them to cohere. Coarse sand from one-twentieth to three-twentieths of an inch in diameter is said to give the best results; the finer sands requiring more care in the preparation of the concrete and in packing it when laid to secure greater solidity.

163. In preparing the concrete the lime and sand are made into heaps of about one cubic yard in volume in alternate layers of the two ingredients. Each heap is then worked up dry with the shovel. In this state it is delivered by suitable machinery, like that for raising grain, into the top of a pug-mill of a cylindrical body formed of boiler iron. The revolving vertical shaft of the mill, which is driven by steam or animal power, has curved arms affixed horizontally to it, the two lower arms being of suitable forms to press the mixed material downwards, and expel it through an aperture, where it is received into boxes, or hand barrows, and conveyed to

where it is to be laid or moulded. The water for the mixing is either thrown in as needed, by hand into the top of the mill, or else supplied by a circular trough perforated with holes, which is placed around the inside of the mill at top. When cement is one of the ingredients, it is first made into a suitable paste with water, and then added to the others, from a vessel over the top of the mill, from which it is poured in a uniform manner, and in the requisite amount.

164. For all ordinary work, one passage through the pug-mill is sufficient, but where greater thoroughness in the mixture is a requisite, the concrete may be passed through the mill a second time.

165. The concrete when laid or moulded is put in in successive layers, from one to three inches in thickness, and packed moderately by hand with pestles weighing from fifteen to thirty pounds.

166. To increase the rapidity of the setting, when necessary, the materials may be heated, in process of mixing, by a spiral tube or worm, through which heated air, steam, or hot water is caused to circulate.

167. Among other artificial conglomerates, that known as Ransome's artificial stone, from the name of the inventor, is now coming into use in England. This material consists of clean river sand the grains of which are cemented with the silicate of lime. To effect this union a silicate of soda is formed, by digesting common flints in a solution of caustic soda, in iron air-tight cylindrical vessels, by means of steam, under a pressure of seventy pounds, which circulates through a coil of iron pipes. The sand, after being thoroughly dried, is mixed with a sufficient volume of finely ground carbonate of lime to fill the voids between the grains. To each bushel of this mixture a gallon of the silicate is added, and the whole thoroughly mixed in a loam mill. The mixture is then moulded, and immediately after the solution of the chloride of calcium is thrown over it with ladles; the moulded blocks are then immersed in the solution, in open tanks, which is kept boiling, by steam passed through it in pipes, for several hours, according to the size of the blocks. This process expels any air that may have been retained in the blocks and facilitates the forming of the silicate of calcium. The block is then taken out and the chloride of sodium, that has been formed, thoroughly washed out with fresh water poured over the block.

This artificial stone is found to be very hard, and some specimens to have offered as great a resistance to rupture, by

compression and extension, as the best sandstones and marbles.

168. General Gillmore in his Report, *Professional Papers, Corps of Engineers*, No. 19, gives the following account of béton-Coignet or aggloméré.

**Béton Aggloméré.** This name is given to a béton of very superior quality, or, more properly speaking, an artificial stone of great strength and hardness, which has resulted from the experiments and researches, extending through many years, of M. François Coignet, of Paris.

The essential conditions which must be carefully observed in making this béton are as follows:

*First.* Only materials of the first excellence of their kind, whether common or hydraulic lime, or hydraulic cement, can be used for the matrix.

*Second.* The quantity of water must not exceed what is barely sufficient to convert the matrix into a stiff, viscous paste.

*Third.* The matrix must be incorporated with the solid ingredients by a thorough and prolonged mixing or trituration, producing an artificial stone paste, decidedly incoherent in character until compacted by pressure, in which every grain of sand and gravel is completely coated with a thin film of the paste. There must be no excess of paste when the matrix is common lime alone. With hydraulic lime this precaution is less important, and with good cement it is unnecessary.

*Fourth.* The béton or artificial stone is formed by thoroughly ramming the stone paste, in thin, successive layers, with iron-shod rammers.

169. The materials employed in making his béton are sand, common lime, hydraulic lime, and Portland cement.

The sand should be as clean as that ordinarily required for mortar, for stone or brick masonry of good quality. Sand containing 5 or 6 per cent. of clay may be used without washing, for common work, by proportionally increasing the amount of matrix. Either fine or coarse sand will answer, or, preferably, a mixture of both, containing gravel as large as a small pea, and even a small proportion of pebbles as large as a hazel nut. There is an advantage in mixing several sizes together, in such proportion as shall reduce the volume of voids to a minimum. Coarse sand makes a harder and stronger béton than fine sand. The extremes to be avoided are a too minute subdivision and weakening of the matrix, by the use of fine sand only, on the one hand, and an undue enlargement of the volume of voids, by the exclusive use of coarse sand, on the other.

The silicious sands are considered the best, though all kinds are employed. When special results are desired in the way of strength, texture, or color, the sand should be selected accordingly.

170. The common lime should be air-slaked, or, better still, it may be slaked by aspersion with the minimum quantity of water that will reduce it to an impalpable powder. It should be passed through a fine wire screen to exclude all lumps, and used within a day or two after slaking, or else kept in boxes or barrels protected from the atmosphere.

It is scarcely practicable, under ordinary circumstances, to employ fat lime alone as the matrix of *béton aggloméré*, particularly in monolithic constructions, in consequence of its tardy induration. Even when used in combination with hydraulic lime or cement it acts as a diluent.

171. Attempts to make *béton* of even average quality without good hydraulic ingredients, have failed in the United States; and it is extremely doubtful whether any characteristic excellence can be attained, after the lapse of weeks or even months, by a mixture of this character.

172. The most suitable hydraulic limes are those derived from the argillaceous limestones, in contradistinction to the magnesian or argillo-magnesian varieties. These limestones contain before burning from 15 to 25 per cent.—generally less than 20 per cent.—of clay. After burning, the lime is slaked to powder by aspersion with water, and sifted to exclude unslaked lumps.

Hydraulic lime cannot be considered an essential ingredient of *béton aggloméré*, except in comparison with common lime. It may be altogether replaced by good hydraulic cement, or it may be used alone, or mixed with common lime, to the entire exclusion of cement. A stiff paste of this lime should set in the air in from ten to fifteen hours, and sustain a wire point one-twenty-fourth of an inch in diameter, loaded with one pound, in eighteen to twenty-four hours. Its energy, and therefore its value, varies directly with the amount of clay which it contains, which generally will not exceed 20 per cent. before burning, although it may reach 25 per cent. Beyond this point the burnt stone can seldom be reduced by slaking and becomes a cement.

No hydraulic lime of this variety has ever been manufactured in the United States. It is not known that stone suitable for it exists here.

173. The heavy slow-setting Portland cements, natural or



artificial, are the only ones suitable for béton aggloméré. They are manufactured extensively throughout Europe.

This cement is produced by burning, with a heat of great intensity and duration, argillaceous limestones, containing from 20 to 22 per cent. of clay, or an artificial mixture of carbonate of lime and clay in similar proportions, and then reducing the product to fine powder between millstones. In this condition its weight should not fall short of 101 pounds and will seldom exceed 128 pounds to the bushel, poured in loosely and struck, without being shaken down or compacted. Between these limits additional weight may always be conferred in the burning, by augmenting the intensity and duration of the heat; and both the tensile strength, and the time required to *set*, increase directly with the weight. For example, a Portland cement weighing 100 pounds to the United States bushel, that will set in half an hour, and sustain when seven days old a tensile strain of 200 pounds on a sectional area of one square inch, would have its time for setting increased to four or five hours, and its tensile strength to about 400 pounds, if burnt to weigh 124 pounds to the bushel. An increase in weight of 24 pounds to the bushel nearly doubles the ultimate tensile strength of Portland cement.

When the matrix of béton aggloméré is Portland cement alone, it is customary to prolong the process of trituration, in order to retard the set; or, if more convenient, the mixture may be passed through the mill twice or even three times, with an interval of an hour or more between each mixing. This course is specially desirable when the cement weighs less than 100 hundred pounds to the bushel, and is correspondingly quick-setting.

174. English engineers generally require that the cement shall be ground so fine that at least 90 per cent. of it shall pass a No. 30 wire sieve, of 36 wires to the lineal inch, and shall weigh not less than 106 pounds to the struck bushel, when loosely poured into the measure. When made into a stiff paste without sand, it should be capable of sustaining without rupture a tensile strain of 400 pounds on a sectional area  $1\frac{1}{2}$  inch square, or  $2\frac{1}{4}$  square inches (equal to 178 pounds to the sectional square inch), seven days after being moulded the sample being immersed six of these days in fresh water.

175. Experience has repeatedly demonstrated, and they have become well recognized facts, that in order to obtain uniformly good béton or artificial stone, with sand, and

either hydraulic lime or Portland cement, or both, it is necessary—

*First.* To regulate, in a systematic manner, the amount of water employed in the manufacture thereof.

*Second.* To obtain, with a minimum quantity of water, the cementing material or matrix in a state of plastic or viscous paste.

*Third.* To cause each grain of sand or gravel to be entirely lubricated with a thin film or coating of this paste; and

*Fourth.* To bring each and every grain into close and intimate contact with those which surround it.

It is also equally true, that the best results possible to be produced from any given materials will be attained when the above-named conditions are enforced.

176. It is impossible to produce a cementing material, of suitable quality for *béton aggloméré*, by the ordinary methods and machinery used for making mortars; for if we take the powder of hydraulic lime or Portland cement, and add the quantity of water necessary to convert it into a paste by the usual treatment, it will usually contain so much moisture, even after being incorporated with the sand, that it cannot be compacted by ramming, but will yield under the repeated blows of the rammer like jelly. If the quantity of water be reduced to that point which would render the mixture, with the usual treatment, susceptible of being thoroughly compacted by rammers, much of the cementing substance will remain more or less inert, and will perform but indifferently well the functions of a matrix.

177. To prepare the matrix, there is taken of the hydraulic lime or cement powder, say one hundred parts, by measure, and of water from thirty to thirty-five or forty parts, which should be the smallest amount that will accomplish the object in view. These are introduced together into a suitable mill, acting upon the materials by both compression and friction, and are subjected to a thorough and prolonged trituration, until the result is a plastic, viscous, and sticky paste, of a peculiar character, in both its physical appearance and the manner in which it comports itself under the subsequent treatment with rammers. There would appear to be no mystery in this part of the process, yet the excellence of the *béton aggloméré* is greatly dependent on its proper execution.

If too much water be used, the mixture cannot be suitably rammed; if too little, it will be deficient in strength.

178 The sand should be deprived of surplus moisture,

although it is not necessary that it be absolutely dry. A uniform state of moisture or dryness should be aimed at, in order that the proper quantity of water may be added with certainty.

179. The matrix in paste, and the sand, having been mixed together in the desired proportions (given hereafter), are then introduced into a powerful mill, and subjected to a thorough and energetic trituration until, without the addition of more water, the paste presents the desired degree of homogeneity and plasticity.

When, for any special purpose, it is desired to introduce into the mixture a quantity of Portland cement, in order to increase the hardness or the rapidity of induration, it had better be added during the process of trituration, mixed with the requisite increment of water, so that after proper mixing the whole material will present the appearance of a short paste, or pasty powder, which is quite characteristic of this process of manipulation.

In ordinary practice, when sand and hydraulic lime only are employed, it will be found to answer very well to mix the two together dry, with shovels, and then spread them out on the floor and sprinkle them with the requisite minimum amount of water. The dampened mixture is then shoveled into the mill and trituated, as already described.

When a portion of Portland cement is used, it may also be incorporated with the other ingredients before the water is added, or introduced into the mixture in the mill, as may be preferred.

When Portland alone is used for the matrix, the process is the same as when lime alone is used, except that the trituration should be more prolonged, especially if the cement be rather light and quick-setting.

Having both equally at command, the following proportions are employed for divers purposes, according to circumstances and the quality of the materials:

Sand, by volume.....	6	5	4	5	5	4	4	5	5	5
Hydraulic lime in powder, by volume.....	1	1	1	1	1	1	1	1	1	1
Portland cement in powder, by volume.....	0	0	0	$\frac{1}{2}$	$\frac{1}{2}$	$\frac{1}{2}$	$\frac{1}{2}$	1	$1\frac{1}{2}$	$1\frac{1}{2}$

It will rarely occur that the proportions given in the two columns on the right of the above table need be used. They

are suitable for ornamented blocks, requiring removal and handling a day or two after being made.

It may sometimes happen that too much water has been introduced in the preparation of the paste. A proper corrective, in such case, is the introduction into the mill of a suitable quantity of each of the ingredients, mixed together dry in the required proportions.

By employing none but white sand and the lighter-colored varieties of lime and cement, a stone closely imitating white marble may be made, while, by the introduction of coloring matter into the paste, such as ochres, oxides, carbonates, etc., or fragments of natural stones, any variations in shade or texture may be produced, from the most delicate buff and drab, to the darkest grays and browns.

In some cases it may be found more convenient to measure the ingredients directly into the mill, alternating with the different materials, in regular order, using for the purpose measures of various sizes, corresponding with the required proportions.

When it is specially desirable to obtain stone of the maximum degree of strength and hardness, the paste may be returned a second or even a third time to the mill, but in all cases the mass must be brought to the characteristic state of incoherent pasty powder, or short paste.

180. The materials, after being mixed to a state of pasty powder, have to be agglomerated in moulds, in order to become *béton* or artificial stone. In other words, the grains of sand and gravel, each coated all over with a thin film of the matrix—entirely exhausting the matrix thereby—have to be brought into close and intimate contact with each other. This is accomplished by ramming the paste in thin, successive layers, in a mould of the form and dimensions required for the stone, and made so as to be capable of sustaining heavy pressure from within, and of being taken apart at pleasure.

Into this mould, supposing it to be for a detached building block, and not for monolithic masonry, a quantity of the stone paste is thrown with a shovel, and spread out in a layer from  $1\frac{1}{2}$  to 2 inches thick. It is then thoroughly compacted by the repeated and systematic blows of an iron-shod rammer, until the stratum of material is reduced to about one-third its original thickness. When this is done, its surface is scratched or roughened up with an iron rake, in order to secure a perfect bond with the succeeding stratum, and more of the material is added and packed in the same manner. This process is continued until the mould is full. The upper surface is then

struck with a straight-edge, and smoothed off with a trowel, after which the full mould may at once be turned over on a bed of sand, and the bottom, side, and end pieces removed. The block is then finished. If small, such as one man can handle, it may be safely removed after one day. Larger pieces, like sills, lintels, steps, platforms, etc., should be allowed a longer time to harden, in consequence of their greater weight.

In case of monolithic masonry, the moulds usually consist of a series of planks placed one above the other horizontally, and supported against exterior uprights, so arranged as to give the required form to the work under construction. These planks are raised up as the wall progresses, so that each day's work shall unite intimately with that of the previous day, producing a smooth and even surface, without joints, ridges, or marks of any kind.

A characteristic property of this stone paste, when properly mixed, is that it does not assume a jelly-like motion when rammed.

Its degree of moisture must be precisely such that the effect of each blow of the rammer shall be distinct, local, and permanent, without disturbing the contiguous material compacted by previous blows. If it be too moist, the mass will shake like wet clay, and if it be too dry, it will break up around the rammer like sand. In either case the materials cannot be compacted and agglomerated in that manner and to that degree which is characteristic of, and peculiar to, *béton aggloméré*.

In monolithic buildings of this *béton*, it is customary to construct all the flues, pipes, and other openings for heating and ventilating, and for conveying water, gas, and smoke, in the thickness of the wall, by using movable cores of the required size and form, around which the material is packed. As the work progresses the cores are moved up.

Ornamental work of simple design may be placed upon the exterior of the building, by attaching the moulds to the planking which gives form to the wall.

More elaborate designs, especially if they are of bold relief, like cornices, and hoods for windows and doors, had better be moulded in detached pieces some days in advance, and hoisted into position when required.

181. All kinds of masonry in thin walls, whether of brick, stone, common concrete, or *béton aggloméré*, are liable to crack from unequal settlement, or from the expansion and contraction due to ordinary changes of temperature. In

houses, such cracks are more to be apprehended at the re-entering angles of the exterior walls, and at the junctions of the exterior and partition walls, than elsewhere. In concrete or *béton* masonry such cracks may be prevented in a great measure, without inconvenience and at a nominal cost, by embedding and incorporating in the work as it progresses, at the angles and junctions referred to, pieces of old scrap-iron of irregular shape, such as bolts, rings, hooks, clamps, wire, etc.

Any masonry of fair quality, constructed in large masses with special reference to inertia, whether to resist the thrusts of earthen embankments, the statical pressure of water, the force of the current in running streams, or for any other purpose, possesses a degree of ultimate strength much greater than the usual factor of safety would require, and largely in excess of any strain that it would ever have to sustain. This excess of strength, or rather the material which confers it, may be readily saved in works built of *béton aggloméré*, by leaving large hollows or voids in the heart of the wall, and filling them up with sand or heavy earth.

Even if the voids remain unfilled, a hollow wall is more stable than a solid one containing the same quantity of material, for the reason that the moments of the forces which confer stability are greater in the former than in the latter.

**182. Durability.** The densest mortars that can be produced from given materials are the best, and the use of a large amount of water is incompatible with the condition of density.

The best pointing mortar, indeed, is a *béton aggloméré*, answering fully to the description of that material, being prepared with a small proportion of water, and applied by caulking it into the joints. In northern climates it has to sustain the severest tests to which masonry of any description can be exposed; to alternations of cold and heat, moisture and dryness, freezing and thawing.

*Béton aggloméré*, when the volume of matrix is so adjusted that the voids in the sand are completely filled—say in the proportion generally of one of the matrix to two and a half or three of sand—becomes in process of time as impervious to water as many of the compact natural stones, while its matured strength exceeds that of the best qualities of sandstone, some of the granites, and many of the limestones and marbles.

Chemical tests have shown this *béton* to be practically impervious to water.

This material, therefore, possesses all the characteristic properties of durability, being dense, hard, strong, and homogeneous; and there would appear to be no reason for supposing that it may not, with entire safety, be applied to out-door constructions, even in the most northerly portions of the United States.

It is injured by freezing before it has had time to set. Important works should not, therefore, be executed during the winter in cold climates.

The effect of freezing on newly made *béton* is to detach a thin scale from the exposed surface, producing a rough and unsightly appearance; but the injury does not extend into the mass of the material, unless the frost be very intense.

In monolithic constructions, the plank *coffre* affords sufficient protection to the face surfaces of the work against moderate frost, and, when the temperature ranges generally not much lower than the freezing point during the day, work may be safely carried on, if care be taken to cover over the new material at night. After it has once set, and has had a few hours to harden, neither severe frost, nor alternate freezing and thawing, has any perceptible effect upon it, and, under any and all circumstances, it is much less liable to injury from these causes, and requires fewer precautions for its protection against them, than common hydraulic concrete.

Monolithic constructions in *béton aggloméré* may advantageously be carried on whenever it is not too cold to lay first-class brick masonry.

In Paris and vicinity operations are not generally suspended during the winter, unless the cold be unusually severe for that climate.

Pieces of statuary, and other specimens ornamented with delicate tracery, have been exposed for five consecutive winters to the weather in New York City, without undergoing the slightest perceptible change.

The power possessed by *béton aggloméré* of resisting the solvent action of salts (principally the sulphates of magnesia and soda) and certain gases contained in sea water, rests upon analogy rather than upon proof based upon adequate experience and observation.

Eminent European engineers do not hesitate to use Portland cement concrete, mixed with a comparatively large dose of water, for very important submarine constructions. The matrix of this concrete possesses less density and strength than that of *béton aggloméré*, and if the lime be excluded

from the latter, the induration in the two cases would be due to precisely the same chemical action. The materials are indeed identical in composition under this condition, with the exception that there is an excess of water, and consequently an element of weakness, in the English concrete, which does not attach to the béton. The durability of the latter in sea water, without being much discussed, has been very generally conceded.

Monolithic constructions under water cannot be executed in béton aggloméré, for the reason that the prescribed ramming in thin layers would necessarily have to be omitted, and some other mode of compacting the mixture followed. This material, however, when laid green through water, loses its distinct name and character, as well as its superior strength and hardness, and becomes common béton or concrete, with the coarser ballast omitted. Its use in this form certainly offers no advantages with regard to strength, while in point of economy the usual proportions of matrix, sand and shingle, or broken stone, is preferable.

**183. Adherence of Mortar.** The force with which mortars in general adhere to other materials, depends on the nature of the material, its texture, and the state of the surface to which the mortar is applied.

**184.** Mortar adheres most strongly to brick; and more feebly to wood than to any other material. Among stones, its adhesion to limestone is generally greatest; and to basalt and sandstones, least. Among stones of the same class, it adheres generally better to the porous and coarse-grained, than to the compact and fine-grained. Among surfaces, it adheres more strongly to the rough than to the smooth.

**185.** The adhesion of common mortar to brick and stone, for the first few years, is greater than the cohesion of its own particles. The force with which hydraulic cement adheres to the same materials, is less than that of the cohesion between its own particles; and, from some recent experiments of Colonel Pasley, on this subject, it would seem that hydraulic cement adheres with nearly the same force to polished surfaces of stone as to rough surfaces.

**186.** From experiments made by Rondelet, on the adhesion of common mortar to stone, it appears that it required a force varying from 15 to 30 pounds on the square inch, applied perpendicular to the plane of the joint, to separate the mortar and stone after six months union; whereas only 5 pounds to the square inch was required to separate the same surfaces when applied parallel to the plane of the joint.



From experiments made by Colonel Pasley, he concludes that the adhesive force of hydraulic cement to stone, may be taken as high as 125 pounds on the square inch, when the joint has had time to harden throughout; but, he remarks, that as in large joints the exterior part of the joint may have hardened while the interior still remains soft, it is not safe to estimate the adhesive force, in such cases, higher than from 30 to 40 pounds on the square inch.

---

## VI.

### MASTICS.

187. The term *Mastic* is generally applied to artificial or natural combinations of bituminous or resinous substances with other ingredients. They are converted to various uses in constructions, either as cements for other materials, or as coatings, to render them impervious to water.

188. **Bituminous Mastic.** The knowledge of this material dates back to an early period; but it is only within, comparatively speaking, a few years that it has come into common use in Europe and this country. The most usual form in which it is now employed, is a combination of mineral tar and powdered bituminous limestone.

189. The localities of each of these substances are very numerous; but they are brought chiefly into the market from several places in Switzerland and France, where these minerals are found in great abundance; the most noted being Val-de-Travers in Switzerland, and Seyssel in France.

190. The mineral tar is usually obtained by boiling in water a soft sandstone, called by the French *molasse*, which is strongly impregnated with the tar. In this process, the tar is disengaged and rises to the surface of the water, or adheres to the sides of the vessel, and the earthy matter remains at the bottom. An analysis of a rich specimen of the Seyssel bituminous sandstone gave the following results:—

Bituminous oil.....	.086	} Bitumen.....	.106
Carbon.....	.020		
Quartz grains.....			.690
Calcareous grains.....			.204
			1.000

191. The bituminous limestone which, when reduced to a powdered state, is mixed with the mineral tar, is known at the localities mentioned by the name of *asphaltum*, an appellation which is now usually given to the mastic. This limestone occurs in the secondary formations, and is found to contain various proportions of bitumen, varying mostly from 3 to 15 per cent., with the other ordinary minerals, as argile, etc., which are met with in this formation.

192. The clay contained in asphaltic rock, as it is not impregnated, like the carbonate of lime, with the bitumen, is hurtful, causing, at times, the cracks seen in asphaltic pavements.

Some rocks contain an oily element, like petroleum, which, rendering the mastic made from them too fat, must first be distilled out.

193. The bituminous mastic is prepared from these two materials by heating the mineral tar in cast-iron or sheet-iron boilers, and stirring in the proper proportion of the powdered limestone. This operation, although very simple in its kind, requires great attention and skill on the part of the workmen in managing the fire, as the mastic may be injured by too low, or too high a degree of heat. The best plan appears to be, to apply a brisk fire until the boiling liquid commences to give out a thin whitish vapor. The fire is then moderated and kept at a uniform state, and the powdered stone is gradually added, and mixed in with the tar by stirring the two well together. When the temperature has been raised too high, the heated mass gives out a yellowish or brownish vapor. In this state it should be stirred rapidly, and be removed at once from the fire.

194. The asphaltic stone may be reduced to powder, either by roasting it in vessels over a fire, or by grinding it down in the ordinary mortar-mill. For roasting, the stone is first reduced to fragments the size of an egg. These fragments are put into an iron vessel; heat is applied, and the stone is reduced to powder by stirring it and breaking it up with an iron instrument. This process is not only less economical than grinding, but the material loses a portion of its tar from evaporation, besides being liable to injury from too great a degree of heat. For grinding, the stone is first broken as for roasting. Care should be taken, during the process, to stir the mass frequently, otherwise it may form into a cake. Cold dry weather is the best season for this operation; the stone, however, should not be exposed to the weather.

195. Owing to the variable quantity of mineral tar in

bituminous limestone, the best proportions of the tar and powdered stone for bituminous mastic cannot be assigned beforehand. Three or four per cent. too much of tar is said to impair both the durability and tenacity of the mastic; while too small a quantity is equally prejudicial. Generally, from eight to ten per cent. of the tar, by weight, has been found to yield a favorable result.

196. Mastics have been formed by mixing vegetable tar, pitch, and other resinous substances, with litharge, powdered brick, powdered limestone, etc.; but the results obtained have generally been inferior to those from bituminous mastic.

197. Mineral tar is more durable than vegetable tar, and on this account it has been used alone as a coating for other materials, but not with the same success as mastic. Employed in this way the tar in time becomes dry and peels off; whereas, in the form of mastic, the hard matter with which it is mixed prevents the evaporation of the oily portion of the tar, and thus promotes its durability.

198. The uses to which bituminous mastic is applied are daily increasing. It has been used for paving in a variety of forms either as a cement for large blocks of stone, or as the *matrix* of a concrete formed of small fragments of stone or gravel; as a pointing, it is found to be more serviceable, for some purposes, than hydraulic cement; it forms one of the best water-tight coatings for cisterns, cellars, the cappings of arches, terraces, and other similar roofings now in use; and is a good preservative agent for wood-work exposed to wet or damp.

---

## VII.

### BRICK.

199. This material is properly an artificial stone, formed by submitting common clay, which has undergone suitable preparation, to a temperature sufficient to convert it into a semi-vitrified state.

Brick may be used for nearly all the purposes to which stone is applicable; for when carefully made, its strength, hardness, and durability, are but little inferior to the more ordinary kinds of building stone. It remains unchanged under the extremes of temperature; resists the action of water; sets firmly

and promptly with mortar; and being both cheaper and lighter than stone, is preferable to it for many kinds of structures, as arches, the walls of houses, &c

200. The art of brick-making is a distinct branch of the useful arts, and does not properly belong to that of the engineer. But as the engineer may at times be obliged to prepare this material himself, the following outline of the process may prove of service.

201. The best brick earth is composed of a mixture of pure clay and sand, deprived of pebbles of every kind, but particularly of those which contain lime, and pyritous or other metallic substances; as these substances, when in large quantities, and in the form of pebbles, act as fluxes, and destroy the shape of the brick, and weaken it by causing cavities and cracks; but in small quantities, and equally diffused throughout the earth, they assist the vitrification, and give it a more uniform character.

202. Good brick earth is frequently found in a natural state, and requires no other preparation for the purposes of the brick-maker. When he is obliged to prepare the earth by mixing the pure clay and sand, direct experiments should in all cases be made, to ascertain the proper proportions of the two. If the clay is in excess, the temperature required to semi-vitrify it will cause it to warp, shrink, and crack; and if there is an excess of sand, complete vitrification will ensue, under similar circumstances.

203. The quality of the brick depends as much on the care bestowed on its manufacture, as on the quality of the earth. The first stage of the process is to free the earth from pebbles, which is most effectually done by digging it out early in the autumn, and exposing it in small heaps to the weather during the winter. In the spring the heaps are carefully riddled, if necessary, and the earth is then in a proper state to be kneaded or tempered. The quantity of water required in tempering will depend on the quality of the earth; no more should be used than will be sufficient to make the earth so plastic as to admit of its being easily moulded by the workman. About half a cubic foot of water to one of the earth is, in most cases, a good proportion. If too much water be used, the brick will not only be very slow in drying, but it will, in most cases, crack, owing to the surface becoming completely dry before the moisture of the interior has had time to escape; the consequence of which will be, that the brick, when burnt, will be either entirely unfit for use, or very weak.

204. Machinery is now coming into very general use in moulding brick: it is superior to manual labor, not only from the labor saved, but from its yielding a better quality of brick, by giving it great density, which adds to its strength.

205. Great attention is requisite in drying the brick before it is burned. It should be placed, for this purpose, in a dry exposure, and be sheltered from the direct action of the wind and sun, in order that the moisture may be carried off slowly and uniformly from the entire surface. When this precaution is not taken, the brick will generally crack from the unequal shrinking, arising from one part drying more rapidly than the rest.

206. The burning and cooling should be done with equal care. A very moderate fire should be applied under the arches of the kiln for about twenty-four hours, to expel any remaining moisture from the raw brick; this is known to be completely effected when the smoke from the kiln is no longer black. The fire is then increased until the bricks of the arches attain a white heat; it is then allowed to abate in some degree, in order to prevent complete vitrification; and it is alternately raised and lowered in this way until the burning is complete, which may be ascertained by examining the bricks at the top of the kiln. The cooling should be slowly effected; otherwise the bricks will not withstand the effects of the weather. It is done by closing the mouths of the arches, and the top and sides of the kiln, in the most effectual manner with moist clay and burnt brick, and allowing the kiln to remain in this state until the warmth has subsided.

207. Brick of a good quality exhibits a fine, compact, uniform texture, when broken across; gives a clear, ringing sound, when struck; and is of a cherry red, or brownish color. Three varieties are found in the kiln: those which form the arches, denominated *arch brick*, are always vitrified in part, and present a grayish glassy appearance at one end; they are very hard, but brittle, of inferior strength, and set badly with mortar; those from the interior of the kiln, usually denominated *body, hard, or cherry brick*, are of the best quality; those from near the top and sides are generally underburnt, and are denominated *soft, pale, or sammel brick*; they have neither sufficient strength nor durability for heavy masonry, nor the outside courses of walls which are exposed to the weather.

208. The quality of good brick may be improved by soak

ing it for some days in water, and re-burning it. This process increases both the strength and durability, and renders the brick more suitable for hydraulic constructions, as it is found not to imbibe water so readily after having undergone it.

209. The size and form of bricks present but trifling variations. They are generally rectangular parallelipeds, from eight to nine inches long, from four to four and a half wide, and from two to two and a quarter thick. Thin brick is generally of a better quality than thick, because it can be dried and burned more uniformly.

210. **Fire-brick.** This material is used for the facing of furnaces, fireplaces, &c., where a high degree of temperature is to be sustained. It is made of a very refractory kind of pure clay, that remains unchanged by a degree of heat which would vitrify and completely destroy ordinary brick. A very remarkable brick of this character has been made of *agoric mineral*; it remains unchanged under the highest temperature, is one of the worst conductors of heat, and so light that it will float on water.

211. **Tiles.** As a roof-covering, tiles are in many respects superior to slate, or metallic coverings. They are strong and durable, and are very suitable for the covering of arches, as their great weight is not so objectionable here as in the case of roofs formed of frames of timber.

Tiles should be made of the best potter's clay, and be moulded with great care, to give them the greatest density and strength. They are of very variable form and size; the worst being the flat square form, as, from the liability of the clay to warp in burning, they do not make a perfectly water-tight covering.

---

## VIII.

### WOOD.

212. This material holds the next rank to stone, owing to its durability and strength, and the very general use made of it in constructions. To suit it to the purposes of the engineer, the tree is felled after having attained its mature growth, and the trunk, the larger branches that spring from the trunk, and the main parts of the root, are cut into suita-

ble dimensions and seasoned, in which state the term *timber* is applied to it. The crooked, or *compass* timber of the branches and roots is mostly applied to the purposes of ship-building—for the knees and other parts of the frame-work of vessels requiring crooked timber. The trunk furnishes all the straight timber.

**213. Trunk.** The trunk of a full-grown tree presents three distinct parts: the *bark*, which forms the exterior coating; the *sap-wood*, which is next to the bark; the *heart*, or inner part, which is easily distinguishable from the sap-wood by its greater firmness and darker color.

**214.** The heart forms the essential part of the trunk, as a building material. The sap-wood possesses but little strength and is subject to rapid decay, owing to the great quantity of fermentable matter contained in it; and the bark is not only without strength, but, if suffered to remain on the tree after it is felled, it hastens the decay of the sap-wood and heart.

**215. Felling.** Trees should not be felled for timber until they have attained their mature growth, nor after they exhibit symptoms of decline; otherwise, the timber will be less strong, and far less durable. Most forest trees arrive at maturity between fifty and one hundred years, and commence to decline after one hundred and fifty or two hundred years. The age of the tree can, in most cases, be ascertained either by its external appearances, or by cutting into the centre of the trunk, and counting the rings, or layers, of the sap and heart, as a new ring is formed each year in the process of vegetation. When the tree commences to decline, the extremities of the old branches, and particularly the top, exhibit signs of decay.

**216.** Trees should not be felled while the sap is in circulation; for this substance is of a peculiarly fermentable nature, and therefore very productive of destruction to the wood. The winter months, and July, are the seasons in which trees are felled for timber, as the sap is generally considered as dormant during these months. This practice, however, is in part condemned by some writers; and the recent experiments of M. Boucherie, in France, support this opinion, and indicate midsummer and autumn as the seasons in which the sap is least active, and therefore as most favorable for felling.

**217. Girdling and Barking.** As the sap-wood, in most trees, forms a large portion of the trunk, experiments have been made for the purpose of improving its strength and durability. These experiments have been mostly directed towards the manner of preparing the tree before felling it.

One method consists in *girdling*, or making an incision with an axe around the trunk, completely through the sap-wood, and suffering the tree to stand in this state until it is dead; the other consists in *barking*, or stripping the entire trunk of its bark, without wounding the sap-wood, early in the spring, and allowing the tree to stand until the new leaves have put forth and fallen before it is felled. The sap-wood of trees, treated by both of these methods, was found very much improved in hardness, strength, and durability; the results from girdling were, however, inferior to those from barking.

**218. Methods of Seasoning.** The seasoning of timber is of the greatest importance, not only to its durability, but to the solidity of the structure for which it may be used; as a very slight shrinking of some of the pieces, arising from the seasoning of the wood, might, in many cases, cause material injury, if not complete destruction to the structure. Timber is considered as sufficiently seasoned, for the purposes of framework, when it has lost about one-fifth of the weight which it has in a green state. Several methods are in use for seasoning timber: they consist either in an exposure to the air for a certain period in a sheltered position, which is termed *natural seasoning*; in immersion in water, termed *water seasoning*; or in boiling, or *steaming*.

**219.** For natural seasoning, it is usually recommended to strip the trunk of its branches and bark immediately upon felling, and to remove it to some dry position, until it can be sawed into suitable scantling. From the experiments of M. Boucherie, just cited, it would seem that better results would ensue from allowing the branches and bark to remain on the trunk for some days after felling. In this state, the vital action of the tree continuing in operation, the sap-vessels will be gradually exhausted of sap and filled with air, and the trunk thus better prepared for the process of seasoning. To complete the seasoning, the sawed timber should be piled under drying-sheds, where it will be freely exposed to the circulation of the air, but sheltered from the direct action of the wind, rain, and sun. By taking these precautions, an equable evaporation of the moisture will take place over the entire surface, which will prevent either warping or splitting, which necessarily ensues when one part dries more rapidly than another. It is further recommended, instead of piling the pieces on each other in a horizontal position, that they be laid on cast-iron supports properly prepared, and with a sufficient inclination to facilitate the dripping of the sap from one end; and that heavy round timber be bored through the centre, to



expose a greater surface to the air, as it has been found that it cracks more in seasoning than square timber.

Natural seasoning is preferable to any other, as timber seasoned in this way is both stronger and more durable than when prepared by any artificial process. Most timber will require, on an average, about two years to become fully seasoned in the natural way.

220. The process of seasoning by immersion in water is slow and imperfect, as it takes years to saturate heavy timber; and the soluble matter is discharged very slowly, and chiefly from the exterior layers of the immersed wood. The practice of keeping timber in water, with a view to facilitate its seasoning, has been condemned as of doubtful utility; particularly immersion in salt water, where the timber is liable to the inroads of those two very destructive inhabitants of our waters, the *Limnoria Terebrans* and *Teredo Navalis*; the former of which rapidly destroys the heaviest logs, by gradually eating in between the annual rings; and the latter, the well-known *ship-worm*, by converting timber into a perfect honey-comb state by its numerous perforations.

221. Steaming is mostly in use for ship-building, where it is necessary to soften the fibres, for the purpose of bending large pieces of timber. This is effected by placing the timber in strong steam-tight cylinders, where it is subjected to the action of steam long enough for the object in view; the period usually allowed is one hour to each inch in thickness. Steaming slightly impairs the strength of timber, but renders it less subject to decay, and less liable to warp and crack.

222. When timber is used for posts partly embedded in the ground, it is usual to char the part embedded, to preserve it from decay. This method is only serviceable when the timber has been previously well seasoned; but for green timber it is highly injurious, as by closing the pores it prevents the evaporation from the surface, and thus causes fermentation and rapid decay within.

223. The most durable timber is procured from trees of a close, compact texture, which, on analysis, yield the largest quantity of carbon. And those which grow in moist and shady localities furnish timber which is weaker and less durable than that from trees growing in a dry, open exposure.

224. **Defects of Timber.** Timber is subject to defects, arising either from some peculiarity in the growth of the tree, or from the effects of the weather. Straight-grained timber, free from knots, is superior in strength and quality as a building material to that which is the reverse.

225. The action of high winds, or of severe frosts, injures the tree while standing: the former separating the layers from each other, forming what is denominated *rolled timber*; the latter cracking the timber in several places, from the surface to the centre. These defects, as well as those arising from worms, or age, are easily seen by examining a cross section of the trunk.

226. **Wet and Dry Rot.** The *wet* and *dry rot* are the most serious causes of the decay of timber; as all the remedies thus far proposed to prevent them are too expensive to admit of a very general application. Both of these causes have the same origin: fermentation, and consequent putrefaction. The wet rot takes place in wood exposed, alternately, to moisture and dryness; and the dry rot is occasioned by want of a free circulation of air, as in confined warm localities, like cellars and the more confined parts of vessels.

Trees of rapid growth, which contain a large portion of sap-wood, and timber of every description, when used green, where there is a want of a free circulation of air, decay very rapidly with the rot.

227. **Preservation of Timber.** Numberless experiments have been made on the preservation of timber, and many processes for this purpose have been patented, both in Europe and this country. Several of these processes have yielded the most satisfactory results; and nearly all have proved more or less efficacious. The means mostly resorted to have been the saturation of the timber in the solution of some salt with a metallic or earthy base, thus forming an insoluble compound with the soluble matter of the timber. The salts which have been most generally tried are, the sulphate of iron or copper, and the chloride of mercury, zinc, or calcium. The results obtained from the chlorides have been more satisfactory than those from the sulphates; the latter class of salts with metallic bases possess undoubted antiseptic properties; but it is stated that the freed sulphuric acid, arising from the chemical action of the salt on the wood, impairs the woody fibre, and changes it into a substance resembling carbon.

228. The processes which have come into most general use are those of Mr. Kyan and of Sir W. Burnett, called after the patentees *kyanizing* and *burnetizing*. Kyan's process is to saturate the timber with a solution of chloride of mercury; using for the solution one pound of the salt to five gallons of water. Burnett uses a solution of chloride of zinc, in the proportion of one pound of the salt to ten gallons of water, for

common purposes; and a more highly concentrated solution when the object is also to render the wood incombustible.

229. As timber under the ordinary circumstances of immersion imbibes the solutions very slowly, a more expeditious, as well as more perfect means of saturation has been used of late, which consists in placing the wood to be prepared in strong wrought-iron cylinders, lined with felt and boards, to protect the iron from the action of the solution, where, first by exhausting the cylinders of air, and then applying a strong pressure by means of a force-pump, the liquid is forced into the sap and air vessels, and penetrates to the very centre of the timber.

230. Among the patented processes in our country, that of Mr. Earle has received most notice. This consists in boiling the timber in a solution of the sulphates of copper and iron. Opinion seems to be divided as to the efficacy of this method. It has been tried for the preservation of timber for artillery carriages, but not with satisfactory results.

231. M. Boucherie, to whose able researches on this subject reference has been made, noticing the slowness with which aqueous solutions were imbibed by wood, when simply immersed in them, conceived the ingenious idea of rendering the vital action of the sap-vessels subservient to a thorough impregnation of every part of the trunk where there was this vitality. To effect this, he first immersed the butt-end of a freshly-felled tree in a liquid, and found that it was diffused throughout all parts of the tree in a few days, by the action in question. But, finding it difficult to manage trees of some size when felled, M. Boucherie next attempted to saturate them before felling; for which purpose he bored an auger-hole through the trunk, and made a saw-cut from the auger-hole outwards, on each side, to within a few inches of the exterior, leaving enough of the fibres untouched to support the tree. One end of the auger-hole was then stopped, as well as all of the saw-cut on the exterior, and the liquid was introduced by a tube inserted into the open end of the auger-hole. This method was found equally efficacious with the first, and more convenient.

232. After examining the action of the various neutral salts on the soluble matter contained in wood, M. Boucherie was led to try the impure pyrolignite of iron, both from its chemical composition and its cheapness. The results of this experiment were perfectly satisfactory. The pyrolignite of iron, in the proportion of one-fiftieth in weight of the green

wood, was found not only to preserve the wood from decay, but to harden it to a very high degree.

233. Observing that the pliability and elasticity of wood depended, in a great measure, on the moisture contained in it, M. Boucherie next directed his attention to the means of improving these properties. For this purpose he tried solutions of various deliquescent salts, which were found to answer the end proposed. Among these solutions he gives the preference to that of chloride of calcium, which also, when concentrated, renders the wood incombustible. He also recommends for like purposes the mother-water of salt-marshes, as cheaper than the solution of the chloride of calcium. Timber prepared in this way is not only improved in elasticity and pliability, but is prevented from warping and cracking; the timber, however, is subject to greater variations in weight than when seasoned naturally.

234. M. Boucherie is of opinion that the earthy chlorides will also act as preservatives, but to insure this he recommends that they be mixed with one-fifth of pyrolignite of iron.

235. From other experiments of M. Boucherie, it appears that the sap may be expelled from any freshly-felled timber by the pressure of a liquid, and the timber be impregnated as thoroughly as by the preceding processes. To effect this, the piece to be saturated is placed in an upright position, so that the sap may flow readily from the lower end; a water-tight bag, containing the liquid, is affixed to the upper extremity, which is surmounted by the liquid, the pressure from which expels the sap, and fills the sap-vessels with the liquid. The process is complete when the liquid is found to issue in a pure state from the lower end of the stick.

237. Either of the above processes may be applied in impregnating timber with coloring matter for ornamental purposes. The plan recommended by M. Boucherie consists in introducing separately the solutions by the chemical union of which the color is to be formed.

238. The rapid decay of railroad sleepers has led to more recent experiments in Europe, where timber is scarce and dear. Opinion now is in favor of impregnating them with creosote, as the best preservative from wet rot.

239. The effect of time on the durability of timber, prepared by any of the various chemical processes which have just been detailed, remains to be seen; although results of the most satisfactory nature may be looked for, considering the severe tests to which most of them have been submitted,

by exposure in situations peculiarly favorable to the destruction of ligneous substances.

**240. Durability of Timber.** The durability of timber when not prepared by any of the above-mentioned processes, varies greatly under different circumstances of exposure. If placed in a sheltered position, and exposed to a free circulation of air, timber will last for centuries, without showing any sensible changes in its physical properties. An equal, if not superior, durability is observed when it is immersed in fresh water, or embedded in thick walls, or underground, so as to be beyond the influence of atmospheric changes.

**241.** In salt water, however, particularly in warm climates, timber is rapidly destroyed by the two animals already noticed: the one, the *limnoria terebrans*, attacking, it is said, only stationary wood, while the attacks of the other, the *teredo navalis*, are general. Various means have been tried to guard against the ravages of these destructive agents; that of sheathing exposed timber with copper, or with a coating of hydraulic cement, affixed to the wood by studding it thickly over with broad-headed nails to give a hold to the cement, has met with full success; but the oxidation of the metal, and the liability to accident of the cement, limit their efficacy to cases where they can be renewed. The chemical processes for preserving timber from decay do not appear to guard them in salt water. A process, however, of preserving timber by impregnating it with coal tar, patented in this country by Professor Renwick, appears, from careful experiments, also to be efficacious against the attack of the ship-worm. A coating of Jeffery's marine glue, when impregnated with some of the insoluble mineral poisons destructive to animal life, is said to subserve the same end.

**242.** The best seasoned timber will not withstand the effects of exposure to the weather for a much greater period than twenty-five years, unless it is protected by a coating of paint or pitch, or of oil laid on hot, when the timber is partly charred over a light blaze. These substances themselves, being of a perishable nature, require to be renewed from time to time, and will, therefore, be serviceable only in situations which admit of their renewal. They are, moreover, more hurtful than serviceable to unseasoned timber, as by closing the pores of the exterior surface they prevent the moisture from escaping from within, and therefore promote one of the chief causes of decay.

**243. Forest Trees of the United States.** The forests of our own country produce a great variety of the best timber for

every purpose, and supply abundantly both our own and foreign markets. The following genera are in most common use.

244. *Oak*. About forty-four species of this tree are enumerated by botanists, as found in our forests and those of Mexico. The most of them afford a good building material, except the varieties of red oak, the timber of which is weak and decays rapidly.

The White Oak (*Quercus Alba*), so named from the color of its bark, is among the most valuable of the species, and is in very general use, but is mostly reserved for naval constructions; its trunk, which is large, serving for heavy frame-work, and the roots and larger branches affording the best compass timber. The wood is strong and durable, and of a slightly reddish tinge; it is not suitable for boards, as it shrinks about  $\frac{1}{2}$  in seasoning, and is very subject to warp and crack.

This tree is found most abundantly in the Middle States. It is seldom seen, in comparison with other forest trees, in the Eastern and Southern States, or in the rich valleys of the Western States.

Post Oak (*Quercus Obtusiloba*). This tree seldom attains a greater diameter than about fifteen inches, and on this account is used mostly for posts, from which use it takes its name. The wood has a yellowish hue, and close grain; is said to exceed white oak in strength and durability; and is therefore an excellent building material for the lighter kinds of frame-work. This tree is found most abundantly in the forests of Maryland and Virginia, and is there frequently called *Box White Oak*, and *Iron Oak*. It also grows in the forests of the Southern and Western States, but is rarely seen farther north than the mouth of the Hudson River.

Chestnut White Oak (*Quercus Prinus Palustris*). The timber of this tree is strong and durable, but inferior to the two preceding species. The tree is abundant from North Carolina to Florida.

Rock Chestnut Oak, (*Quercus Prinus Monticola*.) The timber of this tree is in use mostly for naval constructions, for which it is esteemed inferior only to the white oak. The tree is found in the Middle States, and as far north as Vermont.

Live Oak (*Quercus Virens*). The wood of this tree is of a yellowish tinge; it is heavy, compact, and of a fine grain; it is stronger and more durable than any other species, and on this account it is considered invaluable for the purposes of ship-building, for which it is exclusively reserved.

The live oak is not found farther north than the neighborhood of Norfolk, Virginia, nor farther inland than from fifteen to twenty miles from the seacoast. It is found in abundance along the coast south, and in the adjacent islands as far as the mouth of the Mississippi.

245. *Pine*. This very interesting genus is considered inferior only to the oak, from the excellent timber afforded by nearly all of its species. It is regarded as a most valuable building material, owing to its strength and durability, the straightness of its fibre, the ease with which it is wrought, and its applicability to all the purposes of constructions in wood.

Yellow Pine (*Pinus Mitis*). The heart-wood of this tree is fine-grained, moderately resinous, strong and durable; but the sap-wood is very inferior, decaying rapidly on exposure to the weather. The timber is in very general use for framework, &c.

This tree is found throughout our country, but in the greatest abundance in the Middle States. In the Southern States it is known as *Spruce Pine* and *Short-leaved Pine*.

Long-leaved Pine, or Southern Pine (*Pinus Australis*). This tree has but little sap-wood, and the resinous matter is uniformly distributed throughout the heart-wood, which presents a fine compact grain, having more hardness, strength, and durability than any other species of the pine, owing to which qualities the timber is in very great demand.

The tree is first met with near Norfolk, Virginia, and from this point south it is abundantly found.

White Pine, or Northern Pine (*Pinus Strobus*). This tree takes its name from the color of its wood, which is white, soft, light, straight-grained, and durable. It is inferior in strength to the species just described, and has, moreover, the defect of swelling in damp weather. Its timber is, however, in great demand as a good building material, being almost the only kind in use in the Eastern and Northern States for the framework and joinery of houses, &c.

The finest specimens of this tree grow in the forests of Maine. It is found in great abundance between the 43d and 47th parallels, N. L.

246. Among the forest trees in less general use than the oak and pine, the *Locust*, the *Chestnut*, the *Red Cedar*, and the *Larch* hold the first place for hardness, strength, and durability. They are used chiefly for the framework of vessels. The chestnut, the locust, and the cedar are preferred to all other trees for posts.

247. The Black or Double Spruce (*Abies Nigra*) also affords an excellent material, its timber being strong, durable, and light.

248. The *Juniper* or *White Cedar*, and the *Cypress* are very celebrated for affording a material which is very light, and of great durability when exposed to the weather; owing to these qualities, it is almost exclusively used for shingles and other exterior coverings. These two trees are found in great abundance in the swamps of the Southern States.

---

## IX.

### METALS

The metals in most common use in constructions are *Iron*, *Copper*, *Zinc*, *Tin*, and *Lead*.

249. **IRON.** This metal is very extensively used for the purposes of the engineer and architect, both in the state of *Cast Iron* and *Wrought Iron*.

250. *Cast Iron* is one of the most valuable building materials, owing to its great strength, hardness, and durability, and the ease with which it can be cast, or moulded, into the best forms, for the purposes to which it is to be applied.

251. Cast iron is divided into two principal varieties: the *Gray cast iron*, and *White cast iron*. There exists a very marked difference between the properties of these two varieties. There are, besides, many intermediate varieties, which partake more or less of the properties of these two, as they approach, in their external appearances, nearer to the one or the other.

252. Gray cast iron, when of a good quality, is slightly malleable in a cold state, and will yield readily to the action of the file, when the hard outside coating is removed. This variety is also sometimes termed soft gray cast iron; it is softer and tougher than the white iron. When broken, the surface of the fracture presents a granular structure; the color is gray; and the lustre is what is termed metallic, resembling small brilliant particles of lead strewn over the surface.

253. White cast iron is very hard and brittle; when recently broken, the surface of the fracture presents a distinctly-



marked crystalline structure; the color is white; and lustre vitreous, or bearing a resemblance to the reflected light from an aggregation of small crystals.

254. Mr. Mallet, in a very able Report made to the British Association for the Advancement of Science, remarking on the great want of uniformity, among manufacturers of iron, in the terms used to describe its different varieties, proposes the following nomenclature, as comprising every variety, with their distinctive characters.

**Silvery.** Least fusible; thickens rapidly when fluid by a spontaneous puddling; crystals vesicular, often crystalline, incapable of being cut by chisel or file; ultimate cohesion a maximum; elastic range a minimum.

**Micaceous.** Very soft; greasy feel; peculiar micaceous appearance, generally owing to excess of manganese; soils the fingers strongly; crystals large; runs very fluid; contraction large.

**Mottled.** Tough and hard; filed or cut with difficulty; crystals large and small mixed; sometimes runs thick; contraction in cooling a maximum.

**Bright Gray.** Toughness and hardness most suitable for working; ultimate cohesion and elastic range generally are balanced most advantageously; crystals uniform, very minute.

**Dull Gray.** Less tough than the preceding; other characters alike; contraction in cooling a minimum.

**Dark Gray.** Most fusible; remains long fluid; exudes graphite in cooling; soils the fingers; crystals large and lamella; ultimate cohesion a minimum, and elastic range a maximum.

255. The gray iron is most suitable where strength is required; and the white, where hardness is the principal requisite.

256. The color and lustre, presented by the surface of a recent fracture, are the best indications of the quality of iron. A uniform dark gray color, and high metallic lustre, are indications of the best and strongest. With the same color, but less lustre, the iron will be found to be softer and weaker, and to crumble readily. Iron without lustre, of a dark and mottled color, is the softest and weakest of the gray varieties.

Iron of a light gray color and high metallic lustre is usually very hard and tenacious. As the color approaches to white, and the metallic lustre changes to vitreous, hardness and brittleness become more marked, until the extremes of a dull, or grayish white color, and a very high vitreous lustre,

are attained, which are the indications of the hardest and most brittle of the white variety.

257. The quality of cast iron may also be tested, by striking a smart stroke with a hammer on the edge of a casting. If the blow produces a slight indentation, without any appearance of fracture, it shows that the iron is slightly malleable, and, therefore, of a good quality; if, on the contrary, the edge is broken, it indicates brittleness in the material, and a consequent want of strength.

258. The strength of cast iron varies with its density; and this element depends upon the temperature of the metal when drawn from the furnace; the rate of cooling; the head of metal under which the casting is made; and the bulk of the casting.

259. The density of iron cast in vertical moulds increases, according to Mr. Mallet's experiments, very rapidly from the top downward, to a depth of about four feet below the top; from this point to the bottom, the rate of increase is very nearly uniform. All other circumstances remaining the same, the density decreases with the bulk of the casting; hence large are proportionally weaker than small castings.

260. From all of these causes, by which the strength of iron may be influenced, it is very difficult to judge of the quality of a casting by its external characters; in general, however, if the exterior presents a uniform appearance, devoid of marked inequalities of surface, it will be an indication of uniform strength.

261. The economy in the manufacture of cast iron, arising from the use of the hot blast, has naturally directed attention to the comparative merits between iron produced by this process and that from the cold blast. This subject has been ably investigated by Messrs. Fairbairn and Hodgkinson, and their results published in the *Seventh Report of the British Association*.

Mr. Hodgkinson remarks on this subject, in reference to the results of his experiments: "It is rendered exceedingly probable that the introduction of a heated blast into the manufacture of cast iron, has injured the softer irons, while it has frequently mollified and improved those of a harder nature; and considering the small deterioration that some irons have sustained, and the apparent benefit to those of others, together with the great saving effected by the heated blast, there seems good reason for the process becoming as general as it has done."

262. From a number of specific gravities given in these

Reports, the mean specific gravity of cold blast iron is nearly 7.091, that of hot blast, 7.021.

263. Mr. Fairbairn concludes his Report with these observations, as the results of the investigations of himself and Mr. Hodgkinson: "The ultimatum of our inquiries, made in this way, stands, therefore, in the ratio of strength, 1000 for the cold blast, to 1024.8 for the hot blast; leaving the small fractional difference of 24.8 in favor of the hot blast."

"The relative powers to sustain impact, are likewise in favor of the hot blast, being in the ratio of 1000 to 1226.3."

264. **Wrought Iron.** The color, lustre, and texture of a recent fracture, present, also, the most certain indications of the quality of wrought iron. The fracture submitted to examination, should be of bars at least one inch square; or, if of flat bars, they should be at least half an inch thick; otherwise, the texture will be so greatly changed, arising from the greater elongation of the fibres, in bars of smaller dimensions, as to present none of those distinctive differences observable in the fracture of large bars.

265. The surface of a recent fracture of good iron, presents a clear gray color, and high metallic lustre; the texture is granular, and the grains have an elongated shape, and are pointed and slightly crooked at their ends, giving the idea of a powerful force having been employed to produce the fracture. When a bar, presenting these appearances, is hammered, or drawn out into small bars, the surface of fracture of these bars will have a very marked fibrous appearance, the filaments being of a white color and very elongated.

266. When the texture is either laminated, or crystalline, it is an indication of some defect in the metal, arising either from the mixture of foreign ingredients, or else from some neglect in the process of forging.

267. **Burnt iron** is of a clear gray color, with a slight shade of blue, and of a slaty texture. It is soft and brittle.

268. **Cold short iron**, or iron that cannot be hammered when cold without breaking, presents nearly the same appearance as burnt iron, but its color inclines to white. It is very hard and brittle.

269. **Hot short iron**, or that which breaks under the hammer when heated, is of a dark color without lustre. This defect is usually indicated in the bar by numerous cracks on the edges.

270. The fibrous texture, which is developed only in small bars by hammering, is an inherent quality of good iron; those varieties which are not susceptible of receiving this pe

cular texture, are of an inferior quality, and should never be used for purposes requiring great strength: the filaments of bad varieties are short, and the fracture is of a deep color, between lead gray and dark gray.

271. The best wrought iron presents two varieties; the *Hard* and the *Soft*. The hard variety is very strong and ductile. It preserves its granular texture a long time under the action of the hammer, and develops only the fibrous texture when beaten, or drawn out into small rods: its filaments then present a silver-white appearance.

272. The soft variety is weaker than the hard; it yields easily to the hammer; and it commences to exhibit, under its action, the fibrous texture in tolerably large bars. The color of the fibres is between a silver white and light gray.

273. Iron may be naturally of a good quality, and still, from being badly refined, not present the appearances which are regarded as sure indications of its excellence. Among the defects arising from this cause are *blisters*, *flaws*, and *cinder-holes*. Generally, however, if the surface of fracture presents a texture partly crystalline and partly fibrous, or a fine granular texture, in which some of the grains seem pointed and crooked at the points, together with a light gray color without lustre, it will indicate natural good qualities, which require only careful refining to be fully developed.

274. The strength of wrought iron is very variable, as it depends not only on the natural qualities of the metal, but also upon the care bestowed in forging, and the greater or less compression of its fibres, when drawn or hammered into bars of different sizes.

275. In the Report made by the sub-committee, Messrs. Johnson and Reeves, on the strength of Boiler Iron (*Journal of Franklin Institute*, vol. 20, *New Series*), it is stated that the following order of superiority obtains among the different kinds of pig metal, with respect to the malleable iron which they furnish:—1 *Lively gray*; 2 *White*; 3 *Mottled gray*; 4 *Dead gray*; 5 *Mixed metals*.

The Report states, "So far as these experiments may be considered decisive of the question, they favor the lighter complexion of the cast metal, in preference to the darker and mottled varieties; and they place the mixture of different sorts among the worst modifications of the material to be used, where the object is mere tenacity."

276. These experiments also show that piling iron of different degrees of fineness in the same plate is injurious to its quality, owing to the consequent inequality of the welding.

277. From these experiments, the mean specific gravity of boiler iron is 7.7344, and of bar iron, 7.7254.

278. **Durability of Iron.** The durability of iron, under the different circumstances of exposure to which it may be submitted, depends on the manner in which the casting may have been made; the bulk of the piece employed; the more or less homogeneousness of the mass; its density and hardness.

279. Among the most recent and able researches upon the action of the ordinary corrosive agents on iron, and the preservative means to be employed against them, those of Mr. Mallet, given in the Report already mentioned, hold the first rank. A brief recapitulation of the most prominent conclusions at which he has arrived, is all that can be attempted in this place.

280. When iron is only partly immersed in water, or wholly immersed in water composed of strata of different densities, like that of tidal rivers, a voltaic pile of one solid and two fluid bodies is formed, which causes a more rapid corrosion than when the liquid is of uniform density.

281. The corrosive action of the foul sea water of docks and harbors is far more powerful than that of clear sea or fresh water, owing to the action of the hydro-sulphuric acid which, being disengaged from the mud, impregnates the water, and acts on the iron.

282. In clear fresh river water, the corrosive action is less than under any other circumstances of immersion; owing to the absence of corrosive agents, and the firm adherence of the oxide formed, which presents a hard coat that is not washed off as in sea water.

283. In clear sea water, the rate of corrosion of iron bars, one inch thick, is from 3 to 4 tenths of an inch for cast iron in a century, and about 6 tenths of an inch for wrought iron.

284. Wrought iron corrodes more rapidly in hot sea water than under any other circumstances of immersion.

285. The same iron when chill cast corrodes more rapidly than when cast in green sand; this arises from the chilled surface being less uniform, and therefore forming voltaic couples of iron of different densities, by which the rapidity of corrosion is increased.

286. Castings made in dry sand and loam are more durable under water than those made in green sand.

287. Thin bars of iron corrode more rapidly than those of more bulk. This difference in the rate of corrosion is more

striking in the soft, or *graphitic* specimens of cast iron, than in the hard and silvery. It is caused by the more rapid rate of cooling in thin than in thick bars, by which the density of the surface of the former becomes less uniform. These causes of destructibility may, in some degree, be obviated in castings composed of ribbed pieces, by making the ribs of equal thickness with the main pieces, and causing them to be cooled in the sand, before stripping the moulds.

288. The hard crust of cast iron promotes its durability; when this is removed to the depth of one-fourth of an inch, the iron corrodes more rapidly in both air and water.

289. Corrosion takes place the less rapidly in any variety of iron, in proportion as it is more homogeneous, denser, harder, and closer grained, and the less graphitic.

290. **Preservatives of Iron.**—The more ordinary means used to protect iron against the action of corrosive agents, consist of paints and varnishes. These, under the usual circumstances of atmospheric exposure are of but slight efficacy, and require to be frequently renewed. In water, they are all rapidly destroyed, with the exception of boiled coal-tar, which when laid on hot iron, leaves a bright and solid varnish of considerable durability and protective power.

291. The rapidly increasing purposes to which iron has been applied, within the last few years, has led to researches upon the agency of *electro-chemical* action, as a means of protecting it from corrosion, both in air and water. Among the processes resorted to for this purpose, that of *zinking*, or as it is more commonly known, *galvanizing* iron has been most generally introduced. The experiments of Mr. Mallet, on this process, are decidedly against zinc as a permanent electro-chemical protector. Mr. Mallet states, as the result of his observations, that zinc applied in fusion, in the ordinary manner, over the whole surface of iron, will not preserve it longer than about two years; and that, so soon as oxidation commences at any point of the iron, the protective power of the zinc becomes considerably diminished, or even entirely null. Mr. Mallet concludes: "On the whole, it may be affirmed that, under all circumstances, zinc has not yet been so applied to iron, as to rank as an electro-chemical protector towards it in the strict sense; hitherto it has not become a preventive, but merely a more or less effective palliative to destruction."

292. In extending his researches on this subject, with alloys of copper and zinc, and copper and tin, Mr. Mallet found that the alloys of the last metals accelerate the corro-

sion of iron, when voltaically associated with it in sea water; and that an alloy of the two first, represented by  $23Zn + 8Cu$ , in contact with iron, protects it as fully as zinc alone, and suffers but little loss from the electro-chemical action; thus presenting a protective energy more permanent and invariable than that of zinc, and giving a nearer approximation to the solution of the problem, "to obtain a mode of electro-chemical protection such, that while the iron shall be preserved the protector shall not be acted on, and whose protection shall be invariable."

293. In the course of his experiments, Mr. Mallet ascertained that the softest gray cast iron bears such a voltaic relation to hard bright cast iron, when immersed in sea water and voltaically associated with it, that although oxidation will not be prevented on either, it will still be greatly retarded on the hard, at the expense of the soft iron.

294. In concluding the details of his important researches on this subject, Mr. Mallet makes the following judicious remarks: "The engineer of observant habit will soon have perceived, that in exposed works in iron, equality of section or scantling, in all parts sustaining equal strain, is far from insuring equal passive power of permanent resistance, unless, in addition to a general allowance for loss of substance by corrosion, this latter element be so provided for, that it shall be equally balanced over the whole structure; or, if not, shall be compelled to confine itself to portions of the general structure, which may lose substance without injuring its stability."

"The principles we have already established sufficiently guide us in the modes of effecting this; regard must not only be had to the contact of dissimilar metals, or of the same in dissimilar fluids, but to the scantling of the casting and of its parts, and to the contact of cast iron with wrought iron or steel, or of one sort of cast iron with another. Thus, in a suspension bridge, if the links of the chains be hammered, and the pins rolled, the latter, where equally exposed, will be eaten away long before the former. In marine steam-boilers, the rivets are hardened by hammering until cold; the plates, therefore, are corroded through round the rivets before these have suffered sensibly; and in the air-pumps and condensers of engines working with sea water, or in pit work, and pumps lifting mineralized or 'bad' water from mines, the cast iron perishes first round the holes through which wrought iron bolts, &c., are inserted. And abundant other instances might be given, showing that the effects here spoken of are in prac

tical operation to an extent that should press the means of counteracting them on the attention of the engineer."

295. Since Mr. Mallet's Report to the British Association, he has invented two processes for the protection of iron from the action of the atmosphere and of water; the one by means of a coating formed of a triple alloy of zinc, mercury, and sodium, or potassium; the other by an amalgam of palladium and mercury.

296. The first process consists of forming an alloy of the metals used, in the following manner. To 1,292 parts of zinc by weight, in a state of fusion, 202 parts of mercury are added, and the metals are well mixed, by stirring with a rod of dry wood, or one of iron coated with clay; sodium, or potassium is next added, in small quantities at a time, in the proportion of one pound to every ton by weight of the other two metals. The iron to be coated with this alloy is first cleared of all adhering oxide, by immersing it in a warm dilute solution of sulphuric, or of hydrochloric acid, washing it in clear cold water, and detaching all scales, by striking it with a hammer; it is then scoured clean by the hand with sand, or emery, under a small stream of water, until a bright metallic lustre is obtained; while still wet, it is immersed in a bath formed of equal parts of the cold saturated solutions of chloride of zinc and sal-ammoniac, to which as much more solid sal ammoniac is added as the solution will take up. The iron is allowed to remain in this bath until it is covered by minute bubbles of gas; it is then taken out, allowed to drain a few seconds, and plunged into the fused alloy, from which it is withdrawn so soon as it has acquired the same temperature. When taken from the metallic bath, the iron should be plunged in cold water and well washed.

297. Care must be taken that the iron be not kept too long in the metallic bath, otherwise it may be fused, owing to the great affinity of the alloy for iron. At the proper fusing temperature of the alloy, about 680° Fahr., it will dissolve plates of iron one-eighth of an inch thick in a few seconds; on this account, whenever small articles of iron have to be protected, the affinity of the alloy for iron should be satisfied, by fusing some iron in it before immersing that to be coated.

298. The other process, which has been termed *palladiumizing*, consists in coating the iron, prepared as in the first process for the reception of the metallic coat, with an amalgam of palladium and mercury.

299. **Corrugated Iron.**—This term is applied to sheet iron prepared by being moulded, and having the plane surface



broken by longitudinal or sectional ridges, for the purpose of giving the sheet great stiffness and strength. Corrugated iron is used principally for roofing, and sometimes in place of brick for forming the arches between the iron beams in fire-proof structures.

**300. Steel.**—The name *steel* is given to a compound of iron and carbon, in which the amount of iron is usually not less than 97 per cent. Where the amount of carbon is less than .0065, the compound is termed *steely iron*; when more than 1.8 the compound is cast iron.

Steel, like iron, is seldom pure, containing other substances, of which sulphur and silicon are the most common.

The different kinds of steel are named either from the modes of manufacture, or their appearance, or from some constituent, or from some inventor's process. Thus we have natural steels obtained directly from the ores and bearing mostly local names; blistered, shear, tilted and crucible or cast steel; Woolz or Damask steel; Bessemer's and Martin's steel; tungstein, chromium, and titanium steel.

These varieties are obtained by various processes. Thus we have the *puddling process* by which the varieties of natural steel are made; the cementative process; the Martin-Siemems process; the Bessemer process, &c.

The average specific gravity of natural steels is 7.5; of tilted steel 7.9; cast steel 7.8; Bessemer steel from 7.79 to 7.87; chromium steel from 7.81 to 7.85.

The chromium steel is said to possess the greatest tensile strength; and among those more abundantly manufactured the Bessemer still ranks highest in this respect.

#### COPPER.

**301.** The most ordinary and useful application of this metal in constructions, is that of sheet copper, which is used for roof coverings, and like purposes. Its durability under the ordinary changes of atmosphere is very great. Sheet copper, when quite thin, is apt to be defective, from cracks arising from the process of drawing it out. These may be remedied, when sheet copper is to be used for a water-tight sheathing, by tinning the sheets on one side. Sheets prepared in this way have been found to be very durable.

The alloys of copper and zinc, known under the name of *brass*, and those of copper and tin, known as *bronze*, *gun-metal*, and *bell-metal*, are, in some cases, substituted for iron, owing

to their superior hardness to copper, and being less readily oxidized than iron.

## ZINC.

302. This metal is used mostly in the form of sheets; and for water-tight sheathings it has nearly displaced every other kind of sheet metal. The pure metallic surface of zinc soon becomes covered with a very thin, hard, transparent oxide, which is unchangeable both in air and water, and preserves the metal beneath it from farther oxidation. It is this property of the oxide of zinc, which renders this metal so valuable for sheathing purposes; but its durability is dependent upon its not being brought into contact with iron in the presence of moisture, as the galvanic action which would then ensue, would soon destroy the zinc. On the same account zinc should be perfectly free from the presence of iron, as a very small quantity of the oxide of this last metal, when contained in zinc, is found to occasion its rapid destruction.

Besides the alloys of zinc already mentioned, this metal alloyed with copper forms one of the most useful *solders*; and its alloy with lead has been proposed as a *cramping metal* for uniting the parts of iron work together, or iron work to other materials, in the place of lead, which is usually employed for this purpose, but which accelerates the destruction of iron in contact with it.

## TIN.

303. The most useful application of tin is as a coating for sheet iron, or sheet copper: the alloy which it forms, in this way, upon the surfaces of the metals in question, preserves them for some time from oxidation. Alloyed with lead it forms one of the most useful *solders*.

## LEAD.

304. Lead in sheets forms a very good and durable roof covering, but it is inferior to both copper and zinc in tenacity and durability; and is very apt to tear asunder on inclined surfaces, particularly if covered with other materials, as in the case of the capping of water-tight arches.

821094

## X.

## PAINTS AND VARNISHES.

305. *Paints* are mixtures of certain fixed and volatile oils, chiefly those of linseed and turpentine, with several of the metallic salts and oxides, and other substances which are used either as pigments, or to give what is termed a *body* to the paint, and also to improve its drying properties.

306. Paints are mainly used as protective agents to secure wood and metals from the destructive action of air and water. This they but imperfectly effect, owing to the unstable nature of the oils that enter into their composition, which are not only destroyed by the very agents against which they are used as protectors, but by the chemical changes which result from the action of the elements of the oil upon the metallic salts and oxides.

307. Paints are more durable in air than in water. In the latter element, whether fresh or salt, particularly if foul, paints are soon destroyed by the chemical changes which take place, both from the action of the water upon the oils, and that of the hydrosulphuric acid contained in foul water upon the metallic salts and oxides.

308. However carefully made or applied, paints soon become permeable to water, owing to the very minute pores which arise from the chemical changes in their constituents. These changes will have but little influence upon the preservative action of paints upon wood exposed to the effects of the atmosphere, provided the wood be well seasoned before the paint is applied, and that the latter be renewed at suitable intervals of time. On metals these changes have a very important bearing. The permeability of the paint to moisture causes the surface of the metal under it to rust, and this cause of destruction is, in most cases, promoted by the chemical changes which the paint undergoes.

309. *Varnishes* are solutions of various resinous substances in solvents which possess the property of drying rapidly. They are used for the same purposes as paints, and have generally the same defects.

310. The following are some of the more usual compositions of paints and varnishes.

*White Paint (for exposed wood).*

White lead, ground in oil . . . . .	80
Boiled oil . . . . .	9
Raw oil . . . . .	9
Spirits turpentine . . . . .	4

The white lead to be ground in the oil, and the spirits of turpentine added.

*Black Paint.*

Lamp-black . . . . .	28
Litharge . . . . .	1
Japan varnish . . . . .	1
Linseed oil, boiled . . . . .	73
Spirits turpentine . . . . .	1

*Lead Color.*

White lead, ground in oil . . . . .	75
Lamp-black . . . . .	1
Boiled linseed oil . . . . .	23
Litharge . . . . .	0.5
Japan varnish . . . . .	0.5
Spirits turpentine . . . . .	2.5

*Gray, or Stone Color (for buildings).*

White lead ground in oil . . . . .	78
Boiled oil . . . . .	9.5
Raw oil . . . . .	9.5
Spirits of turpentine . . . . .	3
Turkey umber . . . . .	0.5
Lamp-black . . . . .	0.25

*Lackers for Cast Iron.*

1. — Black lead, pulverized . . . . .	12
Red lead . . . . .	12
Litharge . . . . .	5
Lamp-black . . . . .	5
Linseed oil . . . . .	66
2. — Anti-corrosion . . . . .	40 lbs.
Grant's black, ground in oil . . . . .	4 "
Red lead, as a dryer . . . . .	3 "
Linseed oil . . . . .	4 gals.
Spirits turpentine . . . . .	1 pint

*Copal Varnish.*

Gum copal (in clean lumps) . . . . .	26.5
Boiled linseed oil . . . . .	42.5
Spirits turpentine . . . . .	81

*Japan Varnish.*

Litharge . . . . .	4
Boiled oil . . . . .	87
Spirits turpentine . . . . .	2
Red lead . . . . .	6
Umber . . . . .	1
Gum shellac . . . . .	8
Sugar of lead . . . . .	2
White vitriol . . . . .	1

The proportions of the above compositions are given in 100 parts, by weight, with the exception of lacker 2.

The beautiful black polish on the Berlin castings for ornamental purposes, is said to be produced by laying the following composition on the hot iron, and then baking it.

Bitumen of India.....	0.5
Resin.....	0.5
Drying oil.....	1.0
Copal, or amber varnish.....	1.0

Enough oil of turpentine is to be added to this mixture to make it spread.

311. From experiments made by Mr. Mallet, on the preservative properties of paints and varnishes for iron immersed in water, it appears that caoutchouc varnish is the best for iron in hot water, and asphaltum varnish under all other circumstances; but that boiled coal-tar, laid on hot iron, forms a superior coating to either of the foregoing.

312. **Varnish for Zincked Iron.** Mr. Mallet recommends the following compositions for a paint, termed by him *zoafagous* paint, and a varnish to be used to preserve zincked iron both from corrosion and from fouling in sea water.

To 50 lbs. of foreign asphaltum, melted and boiled in an iron vessel for three or four hours, add 16 lbs. of red lead and litharge ground to a fine powder, in equal proportions, with 10 gals. of drying linseed oil, and bring the whole to a nearly boiling temperature. Melt, in a second vessel, 8 lbs. of gum-animé; to which add 2 gals. of drying linseed oil at a boiling heat, with 12 lbs. of caoutchouc partially dissolved in coal-tar naphtha. Pour the contents of the second vessel into the first, and boil the whole gently, until the varnish, when taken up between two spatulas, is found to be tough and ropy. This composition, when quite cold, is to be thinned down for use with from 30 to 35 gals. of spirits of turpentine, or of coal naphtha.

313. It is recommended that the iron should be heated before receiving this varnish, and that it should be applied with a spatula, or a flexible slip of horn, instead of the ordinary brush.

When dry and hard, it is stated that this varnish is not acted upon by any moderately diluted acid or alkali; and, by long immersion in water, it does not form a partially soluble hydrate, as is the case with purely resinous varnishes and oil paints. It can with difficulty be removed by a sharp-pointed tool; and is so elastic, that a plate of iron covered

with it may be bent several times before it will become detached.

**314. Zoofagous Paint.** To 100 lbs. of a mixture of drying linseed oil, red lead, sulphate of barytes, and a little spirits of turpentine, add 20 lbs. of the oxychloride of copper, and 3 lbs. of yellow soap and common rosin, in equal proportions, with a little water.

When zincked iron is exposed to the atmosphere alone, the varnish is a sufficient protection for it; but when it is immersed in sea water, and it is desirable, as in iron ships, to prevent it from fouling, by marine plants and animals attaching themselves to it, the paint should be used, on account of its poisonous qualities. The paint is applied over the varnish, and is allowed to harden three or four days before immersion.

**315. Methods of Preserving Exposed Surfaces of Stone.** Paints and similar means of preservation from the action of the weather have been used on the exposed surfaces of masonry composed of materials that were found not to withstand well this action; besides these, preparations of the alkaline silicates, known as soluble glass, have of late been recommended as of a more durable character for this purpose. These solutions are applied either by syringes or by a brush to the surface of the stone, it having been previously cleansed of all extraneous matter. Three applications on three successive days are said to be sufficient to harden and preserve any stone.

Another mode of effecting the same object has been proposed, which is to use two solutions of mineral substances which, successively applied to the surface of the stone, shall form an insoluble chemical compound. One method proposed is to saturate the stone at the surface with a weak solution of silicate of potash or soda, on which a solution of chloride of calcium or barium is applied. From this an insoluble silicate of lime or barium will be formed in the pores of the stone, which will render it weather-proof.

Like processes have been used for dyeing or coloring stone for certain architectural effects. For this purpose some of the soluble sulphates are used in various combinations, according to the color to be obtained.

## CHAPTER II.

**316.** **WHATEVER** may be the physical structure of materials, whether fibrous or granular, experiment has shown that they all possess certain general properties, among the most important of which to the engineer are those of *contraction, elongation, deflection, torsion, lateral adhesion, and shearing*, and the resistance which these offer to the forces by which they are called into action.

### EXPERIMENTAL RESEARCHES ON THE STRENGTH OF MATERIALS.

I. GENERAL DEDUCTIONS FROM EXPERIMENTS. II. STRENGTH OF STONE. III. STRENGTH OF MORTARS AND CONCRETES. IV. STRENGTH OF TIMBER. V. STRENGTH OF CAST IRON. VI. STRENGTH OF WROUGHT IRON. VII. STRENGTH OF STEEL. VIII. STRENGTH OF COPPER. IX. STRENGTH OF OTHER MATERIALS. X. LINEAR CONTRACTION AND EXPANSION OF METALS AND OTHER MATERIALS FROM TEMPERATURE. XI. ADHESION OF IRON SPIKES TO TIMBER.

#### SUMMARY.

##### I.

###### GENERAL DEDUCTIONS FROM EXPERIMENTS.

Physical properties of solid bodies and the various experiments to test them (Arts. 316-326).

##### II.

###### STRENGTH OF STONE.

Resistance of stone to crushing and transverse strains (Arts. 327-333).  
Practical deductions (Art. 334).  
Expansion of stone from increase of temperature (Art. 335).

##### III.

###### STRENGTH OF MORTARS AND CONCRETES.

Strength of mortars (Arts. 336-340).  
Strength and other properties of Portland cement (Art. 341).  
Strength of concrete and béton (Art. 342).

## IV.

## STRENGTH OF TIMBER.

Resistance to tensile strain (Art. 343).  
 Resistance to compressive strain (Art. 344).  
 Resistance of square pillars (Art. 345).  
 Resistance to transverse strains (Art. 346).  
 Resistance to detrusion (Art. 347).

## V.

## STRENGTH OF CAST IRON.

Resistance to tensile strain (Art. 348).  
 Resistance to compressive strain (Art. 349-354).  
 Resistance to transverse strain (Art. 355-361).  
 Influence of form upon the strength of cast-iron beams (Art. 362-364).  
 Formulas for determining the ultimate strength of cast-iron beams of the  
 above form (Art. 365).  
 Effect of horizontal impact upon cast-iron bars (Art. 366-367).

## VI.

## STRENGTH OF WROUGHT IRON.

Resistance to tensile strain (Art. 368).  
 Resistance to compressive strain (Art. 369-372).  
 Resistance of iron wire to impact (Art. 373.)  
 Resistance to torsion (Art. 374).

## VII.

## STRENGTH OF STEEL.

Strength and other properties of steel (Art. 375).

## VIII.

## STRENGTH OF COPPER.

Resistance to tensile and compressive strains (Art. 376-377).

## IX.

## STRENGTH OF OTHER METALS.

Strength of cast tin, cast lead, gun-metal, and brass (Art. 378).

## X.

LINEAR CONTRACTION AND EXPANSION OF METALS AND OTHER  
 MATERIALS FROM TEMPERATURE.

## XI.

ADHESION OF IRON SPIKES TO TIMBER.



317. All solid bodies, when submitted to strains by which any of these properties are developed, have, within certain limits, termed the *limits of elasticity*, the property of wholly or partially resuming their original state, when the strain is taken off.

318. To what extent bodies possess the property of total recovery of form, when relieved from a strain, is still a matter of doubt. It has been generally assumed, that the elasticity of a material does not undergo permanent injury by any strain less than about one-third of that which would entirely destroy its force of cohesion, thereby causing rupture. But from the more recent experiments on this point made by Mr. Hodgkinson and others on cast iron, it appears that the restoring power of this material is destroyed by very slight strains; and it is rendered probable that this and most other materials receive a permanent change of form, or *set*, under any strain, however small.

319. The extension, or contraction of a solid, may be effected either by a force acting in the direction in which the contraction or elongation takes place, or by one acting transversely, so as to bend the body. Experiments have been made to ascertain, directly, the proportion between the amount of contraction or elongation, and the forces by which they are produced. From these experiments, it results, that the contractions or elongations are, within certain limits, proportional to the forces, but that an equal amount of contraction, or elongation is not produced by the same amount of force. From the experiments of Mr. Hodgkinson and M. Duleau, it appears that in cast and malleable iron the contraction or elongation caused by the same amount of pressure or tension is nearly equal; while in timber, according to Mr. Hodgkinson, the amount of contraction is about four-fifths of the elongation for the same force.

320. When a solid of any of the materials used in constructions is acted upon by a force so as to produce deflection, experiment has shown that the fibres towards the concave side of the bent solid are contracted, while those towards the convex side are elongated; and that, between the fibres which are contracted and those which are elongated, others are found which have not undergone any change of length. The part of the solid occupied by these last fibres has received the name of the *neutral line* or *neutral axis*.

321. The hypothesis usually adopted, with respect to the circumstances attending this kind of strain, is that the con-

tractions and elongations of the fibres on each side of the neutral axis are proportional to their distances from this line; and that, for slight deflections, the neutral axis passes through the centre of gravity of the sectional area. From experiments, however, by Mr. Hodgkinson and Mr. Barlow, on bars having a rectangular cross-section, it appears that the neutral axis, in forged iron and cast iron, lies nearer to the concave than to the convex surface of the bent solid, and, probably, shifts its position when the degree of deflection is so great as to cause rupture. In timber, according to Mr. Barlow, the neutral axis lies nearest to the convex surface; and, from his experiments on solids of forged iron and timber with a rectangular sectional figure, he places the neutral axis at about three-eighths of the depth of the section from the convex side in timber, and between one-third and one-fifth of the depth of the section from the concave side in forged iron.

322. When the strain to which a solid is subjected is sufficiently great to destroy the cohesion between its particles and cause rupture, experiment has shown that the force producing this effect, whether it act by tension, so as to draw the fibres asunder, or by compression, to crush them, is proportional to the sectional area of the solid.

323. From experiments made to ascertain the circumstances of rupture by a tensile force, it appears that the solid torn apart exhibits a surface of fracture more or less even, according to the nature of the material.

324. Most of the experiments on the resistance to rupture by compression, have been made on small cubical blocks, and have given a measure of this resistance greater than can be depended upon in practical applications, when the height of the solid exceeds three times the radius of its base. This point has been very fully elucidated in the experiments of Mr. Hodgkinson upon the rupture by compression of solids with circular and rectangular bases. These experiments go to prove that the circumstances of rupture, and the resistance offered by the solid, vary in a constant manner with its height, the base remaining the same. In columns of cast iron, with circular sectional areas, it was found that the resistance remained constant for a height less than three times the radius of the base; that, from this height to one equal to six times the radius of the base, the resistance still remained constant, but was less than in the former case; and that, for any height greater than six times the radius of the base, the resistance decreased with the height. In the two first cases the solids were found to yield either by the upper portion sliding off

upon the lower, in the direction of a plane making a constant angle with the axis of the solid; or else by separating into conical or wedge-shaped blocks, having the upper and lower surfaces of the solid as their bases, the angle at the apex being double that made by the plane and axis of the solid. With regard to the resistance, it was found that they varied in the ratio of the area of the bases of the solids. Where the height of the solid was greater than six times the radius of the base, rupture generally took place by bending.

325. From experiments by Mr. Hodgkinson, on wood and other substances, it would appear that like circumstances accompany the rupture of all materials by compression; that is, within certain limits, they all yield by an oblique surface of fracture, the angle of which with the axis of the solid is constant for the same material; and that the resistance offered within these limits are proportional to the areas of the bases.

326. Among the most interesting deductions drawn by Mr. Hodgkinson, from the wide range of his experiments upon the strength of materials, is the one which points to the existence of a constant relation between the resistances offered by materials of the same kind to rupture from compression, tension, and a transverse strain. The following *Table* gives these relations, assuming the measure of the crushing force at 1000.

DESCRIPTION OF MATERIAL.	Crushing force per square inch.	Mean tensile force per square inch.	Mean transverse force of a bar 1 inch square and 1 foot long.
Timber.....	1000	1900	85.1
Cast iron.....	1000	158	19.8
Stone.....	1000	100	9.8
Glass (plate and crown).	1000	128	10

## II.

## STRENGTH OF STONE.

327. The marked difference in the structure and in the proportions of the component elements frequently observed in stone from the same quarry would lead to the conclusion that corresponding variations would be found in the strength of stones belonging to the same class, a conclusion which experiment has confirmed. The experiments made by different individuals on this subject, from not having been conducted in the same manner, and from the omission in most cases of details respecting the structure and component elements of the material tried, have, in some instances, led to contradictory results. A few facts, however, of a general character, have been ascertained, which may serve as guides in ordinary cases; but in important structures, where heavy pressures are to be sustained, direct experiment is the only safe course for the engineer to follow, in selecting a material from untried quarries.

328. Owing to the ease with which stones generally break under a percussive force, and from the comparatively slight resistance they offer to a tensile force and to a transverse strain, they are seldom submitted in structures to any other strain than one of compression; and cases but rarely occur where this strain is not greatly beneath that which the better class of building stones can sustain permanently, without undergoing any change in their physical properties. Where the durability of the stone, therefore, is well ascertained, it may be safely used without a resort to any specific experiment upon its strength, whenever, in its structure and general appearance, it resembles a material of the same class known to be good.

329. The following table exhibits the principal results of experiments made by Mr. G. Rennie, and published in the *Philosophical Transactions of 1818*. The stones tried were in small cubes, measuring one and a half inches on the edge. The table gives the pressure, in tons, borne by each superficial inch of the stone at the moment of crushing.

DESCRIPTION OF STONE.	Spec. gravity.	Crushing w <sup>ght</sup>
<i>Granites.</i>		
Aberdeen, ( <i>blue</i> ).....	2.625	4.83
Peterhead.....	—	3.70
Cornwall.....	2.662	2.83
<i>Sandstones.</i>		
Dundee.....	2.530	2.96
Do.....	2.506	2.70
Derby ( <i>red and friable</i> ).....	2.316	1.40
<i>Limestones.</i>		
Marble ( <i>white-veined Italian</i> )..	2.726	4.32
Do. ( <i>white Brabant</i> ).....	2.697	4.11
Limerick ( <i>black compact</i> ).....	2.598	3.95
Devonshire ( <i>red marble</i> ).....	—	3.31
Portland stone ( <i>fine-grained oolite</i> ).....	2.428	2.04

The following results are taken from a series of experiments made under the direction of Messrs. Bramah & Sons, and published in *Vol. 1, Transactions of the Institution of Civil Engineers*. The first column of numbers gives the weights, in tons, borne by each superficial inch when the stones commenced to fracture; the second column gives the crushing weight, in tons, on the same surface.

DESCRIPTION OF STONE.	Aver. weight producing fractures.	Average crushing weight.
<i>Granites.</i>		
Herme.....	4.77	6.64
Aberdeen ( <i>blue</i> ).....	4.13	4.64
Heytor.....	3.94	6.19
Dartmoor.....	3.52	5.43
Peterhead ( <i>red</i> ).....	2.88	4.83
Peterhead ( <i>blue gray</i> ).....	2.36	4.36
<i>Sandstones.</i>		
Yorkshire.....	2.37	3.94
Craighleith.....	1.69	2.97
Humbic.....	1.69	2.06
Whitby.....	1.00	1.06

The following table is taken from one published in *Vol*

2, *Civil Engineer and Architect's Journal*, which forms a part of the Report on the subject of selecting stone for the New Houses of Parliament. The specimens submitted to experiment were cubical blocks measuring two inches on an edge.

DESCRIPTION OF STONE	Specific gravity.	Weight produ- cing fracture.	Crushing w'ght.
<i>Sandstones.</i>			
Craigleith.....	2.232	1.89	3.5
Darley Dale.....	2.628	2.75	3.1
Heddon.....	2.229	0.82	1.75
Kenton.....	2.247	1.51	2.21
Mansfield.....	2.338	0.88	1.64
<i>Magnesian Limestones.</i>			
Bolsover.....	2.316	2.21	3.75
Huddlestone.....	2.147	1.03	1.92
Roach Abbey.....	2.134	0.75	1.73
Park Nook.....	2.138	0.82	1.92
<i>Oolites.</i>			
Ancaster.....	2.182	0.75	1.04
Bath Box.....	1.839	0.56	0.66
Portland.....	2.145	0.95	1.75
Ketton.....	2.045	0.69	1.18
<i>Limestones.</i>			
Barnack.....	2.090	0.50	0.79
Chilmark ( <i>silicious</i> ).....	2.481	1.32	3.19
Hamhill.....	2.260	0.69	1.80

The numbers of the first column give the specific gravities; those in the second column the weight in tons on a square inch, when the stone commenced to fracture; and those in the third the crushing weight on a square inch.

The following table exhibits the results of experiments on the resistance of stone to a *transverse strain*, made by Colonel Pasley, on prisms 4 inches long, the cross section being a square of 2 inches on a side; the distance between the points of support 3 inches.

330. The conductors of the experiments on the stone for the New Houses of Parliament, Messrs. Daniell and Wheatstone, who also made a chemical analysis of the stones, and applied to them Brard's process for testing their resistance to

DESCRIPTION OF STONE.	Weight of stone per cubic foot in lbs.	Average breaking weight in lbs.
1. Kentish Rag.....	165.69	4581
2. Yorkshire Landing.....	147.07	2887
3. Cornish granite.....	172.24	2808
4. Portland.....	148.08	2682
5. Craigleith.....	144.47	1896
6. Bath.....	122.58	666
7. Well-burned bricks.....	91.71	752
8. Inferior bricks.....	-	329

frost, have appended the following conclusions from their experiments:—"If the stones be divided into classes, according to their chemical composition, it will be found that in all stones of the same class there exists generally a close relation between their various physical qualities. Thus it will be observed that the specimen which has the greatest specific gravity possesses the greatest cohesive strength, absorbs the least quantity of water, and disintegrates the least by the process which imitates the effects of weather. A comparison of all the experiments shows this to be the general rule, though it is liable to individual exceptions."

"But this will not enable us to compare stones of different classes together. The sandstones absorb the least quantity of water, but they disintegrate more than the magnesian limestones, which, considering their compactness, absorb a great deal."

331. Like conclusions to the preceding were reached by a commission for testing the properties of some of the stones and marbles used in the construction of the Capitol at Washington.

But few experiments have been made upon the strength and other properties of the building stones of the United States, and those of a local character. From the reports of a public commission, and of Professor R. Johnson, on the marbles and micaceous stratified stones used in the walls and foundations of the Capitol at Washington, the same general conclusions were arrived at as in the report of Messrs. Daniell and Wheatstone above cited. The strength of the marbles submitted to experiment varied from about seven thousand to twenty-four thousand pounds to the square inch; the micaceous stones used in the foundations averaged about fifteen thousand pounds to the square inch; some specimens of sandstone gave about five thousand pounds to the square inch; and

one of sienite about twenty-nine thousand pounds to the square inch.—*Report of the Architect of Public Buildings, Dec. 1, 1852.*

332. Rondelet, from a numerous series of experiments on the same subject, published in his work, *Art de Bâtir*, has arrived at like conclusions with regard to the relations between the specific gravity and strength of stones belonging to the same class.

Among the results of the more recent experiments on this subject, those obtained by Mr. Hodgkinson, showing the relation between the crushing, the tensile, and the transverse strength of stone, have already been given.

M. Vicat, in a memoir on the same subject, published in the *Annales des Ponts et Chaussées*, 1833, has arrived at an opposite conclusion from Mr. Hodgkinson, stating as the results of his experiments, that no constant relation exists between the crushing and tensile strength of stone in general, and that there is no other means of determining these two forces but by direct experiment in each case.

333. The influence of form on the strength of stone, and the circumstances attending the rupture of hard and soft stones, have been made the subject of particular experiments by Rondelet and Vicat. Their experiments agree in establishing the points that the crushing weight is in proportion to the area of the base. Vicat states, more generally, that the permanent weights borne by similar solids of stone, under like circumstances, will be as the squares of their homologous sides. These two authors agree on the point that the circular form of the base is the most favorable to strength. They differ on most other points, and particularly on the manner in which the different kinds of stone yield by rupture.

334. **Practical Deductions.** Were stones placed under the same circumstances in structures as in the experiments made to ascertain their strength, there would be no difficulty in assigning the fractional part of the weight termed the *working strain* or *working load* which, in the comparatively short period usually given to an experiment, will crush them, could be borne by them permanently with safety. But, independently of the accidental causes of destruction to which structures are exposed, imperfections in the material itself, as well as careless workmanship, from which it is often placed in the most unfavorable circumstances of resistance, require to be guarded against. M. Vicat, in the memoir before mentioned, states that a permanent strain of  $\frac{30}{100}$  of the crushing force of experiment may be borne by stone without danger of impair-



ing its cohesive strength, provided it be placed under the most favorable circumstances of resistance. This fraction of the crushing weight of experiment is greater than ordinary circumstances would justify, and it is recommended in practice not to submit any stone to a greater permanent strain than one-tenth of the crushing weight of experiments made on small cubes measuring about two inches on an edge.

Other authorities state that cut stone in cases like the voussoirs of arches and stone pillars should not be subjected to a working strain greater than  $\frac{1}{10}$ th of the crushing weight of experiment.

The following table shows the permanent strain, and crushing weight, for a square foot of the stones in some of the most remarkable structures in Europe.

	Permanent strain.	Crushing weight.
Pillars of the dome of St. Peter's ( <i>Rome</i> ).....	83330	536000
Do. St. Paul's ( <i>London</i> ).....	39450	537000
Do. St. Geneviève ( <i>Paris</i> ).....	60000	456000
Do. Church of Toussaint ( <i>Angers</i> ).....	90000	900000
Lower courses of the piers of the Bridge of Neuilly..	3600	570000

The stone employed in all the structures enumerated in the Table, is some variety of limestone.

**335. Expansion of Stone from Increase of Temperature.** Experiments have been made in this country by Prof. Bartlett, and in England by Mr. Adie, to ascertain the expansion of stone for every degree of Fahrenheit. The experiments of Prof. Bartlett give the following results :

Granite expands for every degree.....	.000004825
Marble.....	.000005668
Sandstone.....	.000006532

*Table of the Expansion of Stone, etc., from the Experiments of Alexander J. Adie, Civil Engineer, Edinburgh.*

DESCRIPTION OF STONE.	Decimal of an inch on 23 inches for 180° F.	Decimal of length for 180° F.	Decimal of length for 1° F.	Remarks.
1. Roman cement.....	.0320043	.0014349	.00000750	
2. Sicilian white marble.....	.0325392	.0014147	.00000780	} One experiment ( <i>moist</i> ) } Mean of three ( <i>dry</i> ).
	.0253946	.00110411	.00000613	
3. Carrara marble.....	.0274344	.0011928	.00000662	} One experiment ( <i>moist</i> ). } Mean of two ( <i>dry</i> ).
	.0150405	.0000539	.00000363	
4. Sand-stone ( <i>Oraigleith</i> ).....	.0270093	.0011743	.00000652	Mean of four experiments.
5. Slate ( <i>Welch</i> ).....	.0238659	.0010376	.00000576	Mean of three do.
6. Red granite ( <i>Peterhead</i> ).....	.0230416	.0009583	.00000532	} One experiment ( <i>moist</i> ). } Mean of two ( <i>dry</i> ).
	.0206266	.0008968	.00000498	
7. Arbroath pavement.....	.0206652	.0008965	.00000499	Mean of four experiments.
8. Calthness pavement.....	.0205788	.0008947	.00000497	Mean of three do.
9. Green-stone ( <i>Ratho</i> ).....	.0189043	.0008089	.00000449	Mean of three do.
10. Gray granite ( <i>Aberdeen</i> ).....	.01815695	.00078943	.00000438	Mean of two do.
11. Best stock brick.....	.0126542	.0005502	.00000306	Mean of two do.
12. Fire brick.....	.0113334	.0004928	.00000274	Mean of two do.
13. Black marble ( <i>Galloway</i> ).....	.0102394	.00044519	.00000247	Mean of three do.

## III.

## STRENGTH OF MORTARS AND CONCRETES.

336. **Strength of Mortars.** A very wide range of experiments has been made, within a few years back, by engineers both at home and abroad, upon the resistance offered by mortars to a transversal strain, with a view to compare their qualities, both as regards their constituent elements and the processes followed in their manipulation. As might naturally have been anticipated, these experiments have presented very diversified, and in many instances, contradictory results. The general conclusions, however, drawn from them, have been nearly the same in the majority of cases; and they furnish the engineer with the most reliable guides in this important branch of his art.

337. The usual method of conducting these experiments has been to subject small rectangular prisms of mortar, resting on points of support at their extremities, to a transversal strain applied at the centre point between the bearings. This, perhaps, is as unexceptionable and convenient a method as can be followed for testing the comparative strength of mortars.

338. M. Vicat, in the work already cited, gives the following as the average resistances on the square inch offered by mortars to a force of traction; the deductions being drawn from experiments on the resistance to a transversal strain.

Mortars of very strong hydraulic lime.....	170	pounds.
“ ordinary do. ....	140	“
“ medium do. ....	100	“
“ common lime do. ....	40	“
“ do. (bad quality).....	10	“

These experiments were made upon prisms a year old, which had been exposed to the ordinary changes of weather. With regard to the best hydraulic mortars of the same age which had been, during that same period, either immersed in water, or buried in a damp position, M. Vicat states that their average tenacity may be estimated at 140 pounds on the square inch.

339. General Treussart, in his work on hydraulic and common mortars, has given in detail a large number of experiments on the transversal strength of artificial hydraulic mortars, made by submitting small rectangular parallelipeds of mortar, six inches in length and two inches square, to a transversal strain applied at the centre point between the bearings, which were four inches apart. From these experiments he deduces the following practical conclusions.

That when the parallelipeds sustain a transversal strain varying between 220 and 330 pounds, the corresponding mortar will be suitable for common gross masonry; but that for important hydraulic works the parallelipeds should sustain, before yielding, from 330 to 440 pounds.

340. The only published experiments on this subject made in this country are those of Colonel Totten, appended to his translation of General Treussart's work. The results of these experiments are of peculiar value to the American engineer, as they were made upon materials in very general use on the public works throughout the country.

From these experiments Colonel Totten deduces the following general results:

1st. That mortar of hydraulic cement and sand is the stronger and harder as the quality of sand is less.

2d. That common mortar is the stronger and harder as the quantity of sand is less.

3d. That any addition of common lime to a mortar of hydraulic cement and sand weakens the mortar, but that a little lime may be added without any considerable diminution of the strength of the mortar, and with a saving of expense

4th. The strength of common mortars is considerably improved by the addition of an artificial puzzolana, but more so by the addition of an hydraulic cement.

5th. Fine sand generally gives a stronger mortar than coarse sand.

6th. Lime slaked by sprinkling gave better results than lime slaked by drowning. A few experiments made on air-slaked lime were unfavorable to that mode of slaking.

7th. Both hydraulic and common mortar yielded better results when made with a small quantity of water than when made thin.

8th. Mortar made in the mortar-mill was found to be superior to that mixed in the usual way with a hoe.

9th. Fresh water gave better results than salt water.

#### 341. Strength and Other Properties of Portland Cement.

From experiments made in England by Mr. Grant on the resistance to crushing of blocks of Portland cement, and of Portland cement mortars, the following results are deduced.

1st. The strength of the blocks in both cases increased with time. The blocks of pure cement bore respectively nearly 4,000 lbs. on the square inch after three months; over 5,000 lbs. at six months; and nearly 6,000 lbs. at nine months.

2d. The strength of the blocks of mortar also increased with time; but decreased as the volume of sand used was increased. The blocks made with one volume of sand to one of cement bore about 2,500 lbs. on the square inch, and those made of six volumes of sand to one of cement 959 lbs. at the end of three months; whilst those made of one volume of sand to one of cement bore 4,561 lbs. on the square inch at the end of nine months, and those made of six volumes of sand to one of cement bore 1,678 lbs. on the square inch at the end of the same period.

From numerous experiments made by Mr. Grant in England, on Portland cement, he draws the following conclusions:—

1st. Portland cement, if it be preserved from moisture, does not, like Roman cement, lose its strength by being kept in casks or sacks, but rather improves by age.

2d. The longer it is in setting, the more its strength increases.

3d. Very strong Portland cement is heavy, of a blue-gray color, and sets slowly. Quick setting cement has, generally, too large a portion of clay in its composition, is brownish in color, and turns out weak if not useless.

4th. The less the amount of water in working the cement up the better.

5th. It is of the greatest importance that the stones or bricks, with which Portland cement is used, should be thoroughly soaked with water. If under water, in a quiescent state, the cement will be stronger than out of water.

6th. Blocks of brickwork, or of concrete, made with Portland cement, if kept under water until required for use, would be much stronger than if kept dry.

7th. Salt water is as good for mixing with Portland cement as fresh water.

8th. Roman cement is very ill adapted for being mixed with sand.

9th. The resistance of a block of pure Portland cement to extension after an immersion of one year was about 480 lbs. on the square inch; whilst the resistances of blocks made of sand and cement, after the same period of immersion, decreased with the quantity of sand added. Blocks of one volume of cement in paste to one of sand giving three-fourths the resistance of those of pure cement; and those of one volume of cement to five of sand giving only one-sixth of the resistance of blocks of pure cement.

10th. Roman cement is only one-third the strength of Portland cement.—*Proceedings of the Institution of Civil Engineers, Vol. XXV., p. 66.*

**342. Concrete and Beton.** From experiments made on concrete, prepared according to the most approved process in England, by Colonel Pasley, it appears that this material is very inferior in strength to good brick, and the weaker kinds of natural stones.

From experiments made by Colonel Totten on béton, the following conclusions are drawn:

That béton made of a mortar composed of hydraulic cement, common lime, and sand, or of a mortar of hydraulic cement and sand, without lime, was the stronger as the quantity of sand was the smaller. But there may be 0.50 of sand, and 0.25 of common lime, without sensible deterioration; and as much as 1.00 of sand, and 0.25 of lime, without great loss of strength.

Béton made with just sufficient mortar to fill the void spaces between the fragments of stone was found to be less strong than that made with double this bulk of mortar. But Colonel Totten remarks, that this result is perhaps attributable to the difficulty of causing so small a quantity of mortar to penetrate the voids, and unite all the fragments perfectly, in experiments made on a small scale.

The strongest béton was obtained by using quite small

fragments of brick, and the weakest from small, rounded, stone gravel.

A béton formed by pouring grout among fragments of stone, or brick, was inferior in strength to that made in the usual way with mortar.

Comparing the strength of the bétons on which the experiments were made, which were eight months old when tried, with that of a sample of sound red sandstone of good quality, it appears that the strongest prisms of béton were only half as strong as the sandstone.

The working strain on masses of concrete, brick, and rubble masonry seldom exceeds in structures that of one-sixth of the crushing weight of blocks of these materials.

---

#### IV.

##### STRENGTH OF TIMBER.

A wide range of experiments has been made on the resistance of timber to compression, extension, and a transverse strain, presenting very variable results. Among the most recent, and which command the greatest confidence from the ability of their authors, are those of Professor Barlow and Mr. Hodgkinson: the former on the resistance to extension and a transverse strain; the latter on that to compression.

The following Table, taken from Vol. V. Professional Papers of the English Royal Engineers. No. V. Remarks and Experiments on various Woods, give some valuable results on American timber subjected to a strain parallel to the fibre. The column marked C gives the cohesive strength.

	No. of piece and average specific gravity.	No. of experiment.		Mean Transverse Dimensions.		Mean area of Transverse Section.	Breaking weight.	C.		Extreme practical limit of C.	Remarks.	
		B.	D.	lbs.	Approximate proportion.							
ASH, AMERICAN.	9	.6	.607	.3643	3088	8478	...			4800	Mr. Barlow's English ash, sp. gr. 760 C=17337. Mr. Emerson's do., C=6070	
	10	.605	.613	.3705	4051	10925	5-9					
	11	.608	.615	.3759	4142	11077	4-7					
	12	.585	.575	.3363	2522	7517	7-9					
	No. 9	13	.615	.615	.3782	2522	6684	...				
	14	.593	.61	.3617	2675	7395	8-9					
	15	.588	.61	.3586	2387	6656	3-4					
	16	.597	.6	.3582	2580	7202	5-6					
	17	.62	.63	.3844	3473	9035	...					
						8330						
BEECH, AMERICAN.	18	.588	.598	.3516	2956	8319	....			8000	Crushed. Mr. Barlow's English Beech, sp. gr. 696 C=9912. Mr. Tredgold's do., sp. gr. 696, C=2360.	
	19	....	....	....	....	....	....					
	20	.61	.61	.3721	3755	10091	....					
	21	.607	.603	.366	3687	10073	....					
	22	....	....	....	....	....	....					
	23	.63	.612	.3865	3687	9664	....					
	24	.598	.612	....	....	....	....					
					9512							
BIRCH, BLACK AMERICAN.	No. 17	25	.603	.575	.3467	2567	7404	5-6		4250	Mr. Emerson's Birch, 4250.	
	26	.612	.59	.361	2086	5778	9-10					
	27	.628	.56	.3516	2460	6996	5-8					
	28	.627	.597	.3743	2323	7512	11-14					
	29	.601	.597	.3623	1904	5255	3-4					
	30	.595	.597	.3552	1845	8809	...					
						6959						
BLM. CANADA.	No. 29	45	.593	.582	.3451	3528	10223			8000	Records lost.	
	46	.58	.597	.3346	4734	14148						
	47	.587	.58	.3404	4500	13219						
	48	.605	.578	.2496	4263	12193						
	No. 26	49	.597	.575	.3432	4399	12817					
	703	50	.6	.473	.3468	4652	13990					
							13765					

HICKORY, AMERICAN.	No. of piece and average specific gravity.	No. of experiment.		Mean Transverse Dimensions.		Mean area of Transverse Section.	Breaking weight.	C.	Extreme practical limit of C.	Remarks.			
		B.	D.	in.	in.						lbs.	lbs.	Approximate proportion.
No. 33 856	51	.583	.618	.3602	3518	9766	11-13	8000					
	52	.583	.61	.3556	4136	11628	4-5						
	53	.566	.59	.3539	3859	11567	10-13						
	54	.593	.575	.3409	4022	11738	3-4						
	55	.595	.595	.354	3648	10305	5-6						
	56	.595	.588	.3498	3893	11192	10-13						
No. 30 854	57	.63	.608	.383	4372	11420	....						
						11096							
OAK, WHITE AMERICAN.	No. 45 716	80	.59	.595	.351	4414	12547	9-10	6000	Mr. Barlow's Canadian Oak, sp. gr. 872, C=11428.			
		81	.588	.595	.356	4890	13736	6-7					
	82	.587	.597	.3504	3201	9107							
	83	.593	.542	.3241	2058	9126	4-5						
	No. 49 600	84	.59	.585	.3451	2968	8578	4-5					
		85	.597	.598	.357	3088	8646	4-5					
		86	.588	.607	.3569	2755	7719	7-8					
	No. 45 716	87	.608	.627	.3812	3523	9241						
							9750						
	OAK, BASKET, AMERICAN.	No. 51 937	88	.582	.566	.3294	3528	10710			6-7	6000	
89			.607	.573	.3478	3716	10684	7-9					
90			.628	.583	.3661	3353	9158						
91			.542	.61	.3306	3557	10759	5-6					
92			.585	.607	.4077	3265	8253	1-11					
93			.608	.547	.3325	2769	8297	7-9					
94			.602	.603	.363	4129	11374						
							9891						
OAK, ENGLISH, SAWN AND SEASONED.	No. 62 831	120	.605	.605	.366	3276	9224	3-4	5500	"River and green," beats sawn and seasoned," with reference to both B and C. The uninjured state of the grain has, I apprehend, more to do with the strength than the condition as to the dryness.			
		121	.595	.605	.3599	2315	6422	7-10					
		122	.605	.606	.366	2725	7445						
	123	.593	.6	.3558	2315	6506							
	No. 63 836	124	.598	.61	.3647	3213	8809	7-11					
		125	.6	.605	.363	2963	8162	7-11					
		126	.6	.59	.334	2408	6802	5-6					
		127	.585	.6	.351	2408	6860						
						7530							
	OAK, HOLM, AMERICAN.	No. 65 1230	128	.598	.6	.3588	3528	9832				4000	Records lost.
129			.603	.6	.3618	2688	7429						
No. 67 1141		130	.59	.608	.3587	4113	11466						
		131	.57	.603	.3437	3111	9051						
No. 68 1140		132	.637	.577	.3617	2128	5833						
		133	.597	.573	.3420	2128	6222						
							8814						



PINE, RED AMERI- CAN.	No. of piece and average specific gravity.	No. of experiment.		Mean Transverse Dimen- sions.		Mean area of Trans- verse Section.	Breaking weight.	C.	Extreme practical limit of C.		Remarks.	
		B.	D.	in.	in.				lbs.	lbs.		lbs.
PINE, RED AMERI- CAN.	No. 76 568	134	.585	.607	.355	1528	4304	2-3	3000	Mr. Barlow's New England Fir, sp. gr. 553, C=9647.		
		135	.587	.6	.3522	1925	5467	2-3				
		136	.582	.592	.3445	1868	5422	2-3				
	No. 78 639	137	.587	.59	.3463	1748	5047	3-5	3000	Mr. Tredgold's Yellow Ameri- can, sp. gr. 460, C=3900.		
		138	.587	.59	.3463	1975	5703	2-3				
		139	.588	.64	.3763	2449	6508					
						5408						
PINE, WHITE AMERICAN.	No. 71 460	140	.62	.625	.3875	1424	3674	5-7	2200			
		141	.607	.602	.3654	1204	3295	2-3				
		142	.63	.627	.395	1555	3936	5-6				
		143	.635	.635	.3968	1397	3520	5-7				
		144	.607	.625	.3738	1295	3418	10-15				
		145	.627	.617	.3868	1408	3640	....				
							3580					

343. Resistance to Tensile Strain. The following table exhibits the specific gravity, and the mean resistance per square inch of various kinds of timber, from the experiments of Prof. Barlow.

The working strain on beams subjected to extension should not exceed  $\frac{1}{3}$  of the rupturing strain in permanent structures, but for temporary purposes, like scaffolding, &c., it may be placed at  $\frac{1}{4}$ th the rupturing strain with safety.

But few direct experiments have been made upon the elongations of timber from a strain in the direction of the fibres. From some made in France by MM. Minard and Desormes, it would appear that bars of oak having a sectional area of one square inch will be elongated .001176 of their length by a strain of one ton.

344. Resistance to Compressive Strains. The following Table exhibits the results obtained by Mr. Hodgkinson from experiments on short cylinders of timber with flat ends. The diameter of each cylinder was one inch, and its height two inches. The results, in the first column, are a mean from about three experiments on timber moderately dry, being such as is used for making models for castings; those in the second column were obtained in a like manner, from similar

DESCRIPTION OF TIMBER.	Spec. grav.	Mean strength of cohesion per square inch.
Ash ( <i>English</i> ).....	0.760	17000
Beech, do. ....	0.700	11500
Box.....	1.000	20000
Deal ( <i>Christiania</i> ).....	0.680	11000
Do. ( <i>Memel</i> ).....	0.590	11000
Elm.....	0.540	5780
Fir ( <i>New England</i> ).....	0.550	12000
Do. ( <i>Riga</i> ).....	0.750	12600
Do. ( <i>Mar Forest</i> ).....	0.700	12000
Larch ( <i>Scotch</i> ).....	0.540	7000
Locust.....	0.950	20580
Mahogany.....	0.637	8000
Norway spars.....	0.580	12000
Oak ( <i>English</i> ).....	{ from 0.700	9000
	{ to 0.900	15000
Do. ( <i>African</i> ).....	0.980	14400
Do. ( <i>Adriatic</i> ).....	0.990	14000
Do. ( <i>Canadian</i> ).....	0.872	12000
Do. ( <i>Dantzic</i> ).....	0.700	14500
Pear.....	0.646	9800
Poon.....	0.600	14000
Pine ( <i>pitch</i> ).....	0.660	10500
Do. ( <i>red</i> ).....	0.660	10000
Teak.....	0.750	15000

specimens, which were turned and kept dry in a warm place two months longer. A comparison of the results in the two columns shows the effect of drying on the strength of timber; wet timber not having half the strength of the same when dry. The circumstances of rupture were the same as already stated in the general observations under this head; the height of the wedge which would slide off in timber being about half the diameter or thickness of the specimen crushed.

**345. Resistance of Square Pillars.** Mr. Hodgkinson has made a number of invaluable experiments on the strength of pillars of timber, and of columns of iron and steel, and from them has deduced formulæ for calculating the pressure which they will support before breaking. The experiments on timber were made on pillars with flat ends. The following are the formulæ from which their strength may be estimated.

Calling the breaking weight in lbs.,  $W$ .

“ the side of the square base in inches,  $d$ .

“ the length of the pillar in feet,  $l$ .

DESCRIPTION OF WOOD.	Strength per square inch in lbs.	
Alder.....	6881	6960
Ash.....	8688	9368
Baywood.....	7518	7518
Beech.....	7738	19868
Birch ( <i>American</i> ).....	8297	11668
Do. ( <i>English</i> ).....	8297	6403
Cedar.....	5674	5868
Crab.....	6499	7148
Red deal.....	5748	6596
White deal.....	6781	7298
Elder.....	7451	9978
Elm.....	-	10831
Fir ( <i>spruce</i> ).....	6499	6819
Hornbeam.....	4538	7399
Mahogany.....	8198	8198
Oak ( <i>Quebec</i> ).....	4231	5968
Do. ( <i>English</i> ).....	6484	10058
Do. ( <i>Dantzic, very dry</i> ).....	-	7781
Pine ( <i>pitch</i> ).....	6790	6790
Do. ( <i>yellow, full of turpentine</i> ).....	5875	5445
Do. ( <i>red</i> ).....	5895	7518
Poplar.....	8107	5124
Plum ( <i>wet</i> ).....	8654	-
Do. ( <i>dry</i> ).....	8241	to 1049
Sycamore.....	7082	-
Teak.....	-	12101
Larch ( <i>fallen two months</i> ).....	8301	5568
Walnut.....	6068	7237
Willow.....	2898	6128

Then for long columns of oak, in which the side of the square base is less than  $\frac{1}{10}$ th the height of the column;

$$W = 24542 \frac{d^2}{l}$$

and for red deal,

$$W = 17511 \frac{d^2}{l}$$

For shorter pillars, where the ratio between their thickness and height is such that they still yield by bending, the strength is estimated by the following formula:

Calling the weight calculated from either of the preceding formulæ,  $W$ .

Calling the crushing weight, as estimated from the preceding table,  $W'$ .

Calling the breaking weight in lbs.,  $W''$ .

Then the formula for the strength is

$$W'' = \frac{W W'}{W + \frac{1}{2} W'}$$

In each of the preceding formulæ  $d$  must be taken in inches, and  $l$  in feet.

The same rule is followed in proportioning the rupturing to the working strain in timber subjected to compression as in timber subjected to extension.

**346. Resistance to Transverse Strains.** As timber, from the purposes to which it is applied, is for the most part exposed to a transverse strain, the far greater number of experiments have been made to ascertain the relations between the strain, the deflection caused by it, and the linear dimensions of the piece subjected to the strain. These relations have been made the subject of mathematical investigations, founded upon data derived from experiment, which will be given in the APPENDIX. The following table exhibits the results of experiments made upon beams having a rectangular sectional area, which were laid horizontally upon supports at their ends, and subjected to a strain applied at the middle point between the supports, in a vertical direction.

For a more convenient application of the formulæ to the results of the experiments, the notation adopted in the preceding Art. will be here given.

Call the transverse force necessary to break the beam in lbs.,  $W$ .

Call the distance between the supports in inches,  $l$ .

“ the horizontal breadth of the sectional area in inches,  $b$ .

Call the vertical depth of the sectional area in inches,  $d$ .

“ the deflection arising from a weight  $w$  in inches,  $f$ .

*Table of Experiments with the foregoing Notation.*

DESCRIPTION OF WOOD.	Specific grav.	Values of $l$ .	Values of $b$ .	Value of $d$ .	Value of $f$ .	Value of $w$ .	Value of $W$ .	Authors of experiments.
		Inches.	Inches.	Inches.	Inches.	lbs.	lbs.	
Oak ( <i>English</i> ),.....	.934	84	2	2	1.290	300	637	Prof. Barlow.
Do. ( <i>Canadian</i> ),.....	.872	84	2	2	1.080	225	673	“
Pine ( <i>American</i> ),.....	-	84	2	2	0.931	150	-	“
Oak ( <i>English</i> ),.....	-	30	1	1	0.5	137	-	Tredgold,
White spruce ( <i>Canadian</i> ),.....	.465	24	1	1	0.5	180	285	“
White pine ( <i>American</i> )	.455	85.2	2.75	5.55	0.177	777	5189	Lieut. Brown
Black spruce, do.	.490	85.2	2.75	5.55	0.177	892	5646	“
Southern pine, do.	.872	85.2	2.75	5.54	0.177	1175	9237	“

The following Table, taken from Vol. V. *Professional Papers of the English Royal Engineers. No. V. Remarks and Experiments on various Woods*, gives the value of  $S$ , in the formula  $S = \frac{Wl}{4ad^3}$ , for transverse strains, in which  $l$ , the length of the pieces subjected to experiment, was from five to six feet; the distance between the points of support four feet; the ends of the pieces not confined

	No. of experiment.	Specific gravity.	Transverse dimensions.		Breaking weight.	Ultimate deflection.	Weight giving a deflection = 1.00 length.	Weight at which the deflections ceased to be at all uniform.	Corresponding deflections.	Value of $S$ from formula $S = \frac{Wl}{4ad^3}$	No. of weights applied successively.	Detail Remarks.
			Mean depth.	Mean breadth.								
ASH, AMERICAN	7	618	in. 1.98	in. 1.98	lbs. 1101	in. 2.0	lbs. 390	lbs. 642	in. .8	1702	21	Good specimen; gave warning at 1017 lbs., then fell rapidly and broke at 1101 lbs. Tolerable specimen; gave warning gradually at 751 lbs. Do. as No. 8.
	8	580	2.0	1.85	803	1.8	298	478	.8	1300	16	
	9	636	2.0	1.85	1017	3.0	271	534	.925	1649	19	
		611								1550		
BEECH, AMERL-CAN.	10	782	2.05	1.98	1341	2.7	428	697	.85	1790	24	Tolerable specimen; gave warning at 603 lbs. Good specimen; gave warning at 1017 lbs. Do. broke well and gradually.
	11	788	2.0	2.0	1073	1.9	416	642	.775	1609	20	
	12	765	1.98	2.0	1157	2.6	428	534	.625	1770	24	
		778								1723		
BIRCH, BLACK AMERL-CAN.	13	764	2.0	2.0	1521	1.7	540	1241	1.275	2282	30	Very good specimen; warning at 1270 lbs., broke suddenly at 1521. Good specimen; broke suddenly at 1297 lbs. Do., broke with a long scarf and gradually. Do., broke well, but with little warning. Do. Do. Do. All taken from the same piece.
	14	646	2.0	1.98	1297	2.8	390	697	.875	1965	26	
	15	780	2.0	2.0	1017	2.7	487	642	1.1	1525	24	
	16	634	2.0	2.0	1129	2.5	536	803	1.17	1693	25	
	17	645	2.0	2.0	1185	3.3	470	642	1.1	1777	25	
	682								1848			
ELM, CAN.-A.L.A.	26	703	2.046	2.008	1377	3.1	290	761	0.9	1966	38	The great uniformity of texture in this wood presented no irregularities for comment during straining.
	27	700	2.05	2.037	1265	2.5	456	649	1.5	1799	35	
	28	712	2.037	2.03	1321	3.5	483	673	0.8	1891	36	
	29	685	2.03	2.025	1265	3.5	451	621	0.74	1819	35	
		700								1869		

	No. of experiment.	Specific gravity		Transverse dimensions.		Breaking weight.	Ultimate deflection.	Weight giving a deflection = 1-100 length.	Weight at which the deflections ceased to be at all uniform.	Corresponding deflections.	Value of S from formula $S = \frac{Wl}{bd^3}$	No. of weights applied successively.	Detail Remarks.
		Mean depth.	Mean breadth.	in.	in.								
HICKORY, AMERICAN.	30	854	2.0	2.0	1330	3.0	390	857	1.75	1995	27	Good piece, but with a small knot 12 inches from centre; gave warning at 1129 lbs., broke at 1330 equally at the knot and centre.	
	31	838	1.98	1.97	857	1.2	390	590	.7	1332	16	Indifferent specimen, two-fifths sap.	
	32	866	2.03	2.0	1270	1.9	481	910	.975	1607	29	Good specimen, warning at 642 lbs.	
	33	856	2.0	1.98	1157	3.0	405	590	.7	1753	23	Do. warning at 1128 lbs., broke well and gradually.	
		871									1672		
OAK, WHITE-AMERICAN.	45	716	1.93	1.92	1300	2.0	370	751	1.025	2181	30	Good specimen, warning at 1240 lbs.	
	46	...	1.95	1.92	963	2.0	331	478	.75	1582	18	Broke soon at a knot; no specific gravity mentioned, 46 and 47 having been at first supposed to be too unsatisfactory; they were, however, recorded, as No. 50 did not give a very much better result.	
	47	....	1.93	1.93	803	2.0	426	642	.775	1342	15		
	48	666	2.05	2.03	1120	1.9	386	590	1.0	1580	22	Good-looking specimen, but slightly tainted with dry-rot; broke with little warning.	
	49	600	2.00	2.03	1297	2.0	349	478	.65	1916	26	Do. Do. broke with a long scarf.	
	50	600	2.17	0.86	534	1.8	211	366	.9	1582	10	A slab specimen from 48.	
		645									1699		
OAK, BASKET, AMERICAN.	51	937	1.83	1.69	910	3.5	244	478	1.15	1929	17	Fair specimen; warning at about 400 lbs., broke with a long scarf.	
	52	947	1.81	1.68	697	3.6	207	310	1.6	1339	13	Broke at a large worm-hole, to which this wood seems to be subject.	
	53	937	1.8	1.6	808	3.0	....	478	1.3	1369	15	Do. These three specimens were all from the same log.	
		940									1709		

	No. of experiment.	Specific gravity.		Transverse dimensions.		Breaking weight.	Ultimate deflection.	Weight giving a deflection = 1-100 length.	Weight at which the deflections ceased to be at all uniform.	Corresponding deflections.	Value of S from formula $S = \frac{wl}{ad^3}$ .	No. of weights applied successively.	Detail Remarks.					
		Mean depth.	Mean breadth.	in.	in.									lbs.	in.	lbs.	lbs.	in.
OAK, AMERICAN, HOLM OR LIVE OAK.	64	1.120	2.029	2.004	1041	1.8	338	313	.86	1513	28	Evidently a bad specimen, though it looked well.						
	65	1.230	2.025	2.015	1433	2.4	424	505	.67	2080	35							
	66	1.121	2.046	2.039	1265	2.3	393	313	.74	1780	32							
	67	1.141	2.029	1.99	1489	3.8	429	313	.7	2181	36							
	68	1.140	2.042	2.023	873	1.8	347	257	.63	.....	24							
	69	1.209	2.025	2.017	1209	2.2	368	453	.58	1756	31							
	1160									1862								
PINE, WHITE AMERICAN.	70	422	2.01	2.0	910	1.8	316	534	.75	1351	16	Good clean specimen; broke short without warning.						
	71	450	2.0	2.0	910	1.7	243	590	.8	1365	16							
	72	432	2.0	2.0	910	1.8	337	590	.85	1365	16							
	73	480	2.008	1.99	1041	.....	.....	.....	.....	1557	28							
	74	480	1.98	1.97	985	.....	.....	.....	.....	1531	27							
	75	453	2.0	1.99	1041	.....	.....	.....	.....	1569	28							
	453									1456								
PINE, RED AMERICAN.	76	568	2.0	1.98	1157	2.1	369	642	.8	1753	23	Snapped at the centre; though there was a knot 8 inches from it. Good clean specimen.						
	77	656	2.0	2.0	1420	2.5	459	590	.6	2130	32							
	78	639	2.0	2.0	1300	2.1	459	903	1.125	1950	28							
		621								1944								

**Deflection of Wooden Beams.** Professor W. A. Norton, of the Scientific School of Yale College, made a careful series of experiments, to test the practical accuracy of the formula derived from the generally-received theory of the deflection of beams of a rectangular cross-section, arising from a weight acting at the middle point of the beam resting on two supports, its axis being horizontal.

This formula is:  $f = m \frac{Pl}{E b d^3}$ ; in which

$P$  is the applied pressure;  $f$ , the deflection due to  $P$ ;  $E$ , the modulus of elasticity of the material;  $b$ , the breadth;  $d$ , the

depth; and  $l$ , the distance between the points of support of the beam; and  $m$ , a constant to be derived from experiment.

From this formula, if accurate, the amount of deflection should vary directly as the pressure and cube of the length, and inversely as the breadth and cube of the depth; but from Prof. Norton's experiments it appears:—

1. That the deflection varies approximately as the pressures, but rather increasing according to a less rapid law.

2. That, although the deflections are not uniformly inversely as the breadth, still the variation from this law is but slight.

3. That, except in "beams whose length bore a high proportion to their depth," the law indicated, that the deflections are inversely proportional to the cubes, is far from being accurate. In other cases it "decreases according to a less rapid law than the inverse cube of the depth."

4. The experiments also show, that the law, that the deflection is directly proportional to the cube of the length, also fails.

From these experiments Prof. Norton says:—

"We may conclude, from these results, that the deflection increases according to a less rapid law than the cube of the length of the stick. We have already seen that it decreases in a less rapid proportion than the inverse cube of the depth. It follows, therefore, that the true formula for the deflection probably contains at least one additional term, which varies less rapidly than as the cube of the length directly and the cube of the depth inversely; or in other words, contains  $l$  in the numerator, and  $d$  in the denominator, each raised to a lower power than the cube."

"Further, it would seem, then, that the true theory of deflection conducts to the following formula, in the special case of a beam resting on two supports and loaded in the middle.

$$f = c \frac{Pl}{bd} + \frac{Pl^3}{4Ebd^3}."$$

The following table gives the values of  $E$  for white pine, and the calculated values of the constant  $C$ .

"The general formula applicable to white pine sticks of the general quality used in these experiments will be obtained by taking the mean of the several values of  $E$  and  $C$  given in the above table. To test the theoretical formula we have obtained we will take the mean values of  $E$  and  $C$ , for the second set of sticks, given at the bottom of the fourth and fifth columns, viz.:  $E=1,427,965$  pounds, and  $C=0.0000094$ . We thus have



$$f = 0.0000094 \frac{Pl}{bd} + \frac{P^2}{5,711,860 \times bd^3}$$

or, taking  $P = 100$  lbs.,

$$f = 0.00094 \frac{l}{bd} + \frac{P}{57,118.6 \times bd^3}$$

The general formula for the deflection may also take the following form:

$$f = \frac{P^2}{4 Ebd^3} (4 EC \frac{d^2}{P} + 1).$$

TABLE.

Sticks.					Diff. of Extreme Pressures.		Diff. of Intermediate Pressures.	
Set No. 1.					E.	C.	E.	C.
l.		b.		a.				
ft.	in.	ft.	in.	ft.				
2, or 4	2	1	1	1	1,359,500 lbs.	0.0000108	1,308,430 lbs.	0.0000082
2	2, or 3	3, or 2	3, or 2	1	1,566,809 "	0.0000100	1,579,990 "	0.0000095
4	2, or 3	3, or 2	3, or 2	1	1,584,820 "	0.0000087	1,560,800 "	0.0000078
2, or 4	4	2	2	2	1,532,000 "	0.0000140	1,501,200 "	0.0000127
2, or 4	2	2	2	2	1,481,800 "	0.0000108	1,423,600 "	0.0000094
Means.....					1,508,986 "	0.0000108	1,474,798 "	0.0000090
Set No. 2.								
2, or 4	3	2	2	2	1,277,729 lbs.	0.0000084	1,254,000 lbs.	0.0000080
2, or 4	2	3	3	2	1,295,984 "	0.0000089	1,315,000 "	0.0000088
2, or 4	4	2	2	2	1,568,900 "	0.0000110	1,542,860 "	0.0000107
2, or 4	2	2	2	2	1,561,822 "	0.0000084	1,600,000 "	0.0000100
Means.....					1,423,609 "	0.0000092	1,427,965 "	0.0000094

347. Resistance to Detrusion. From the experiments of Prof. Barlow, it appears that the resistance offered by the lateral adhesion of the fibres of fir, to a force acting in a direction parallel to the fibres, may be estimated at 592 lbs. per square inch.

Mr. Tredgold gives the following as the results of experiments on the resistance offered by adhesion to a force applied perpendicularly to the fibres to tear them asunder.

- Oak.....2316 lbs. per square inch.
- Poplar.....1783 " "
- Larch, 970 to 1700 " "

## V.

## STRENGTH OF CAST-IRON.

The most recent experiments on the strength of this material are those of Mr. Hodgkinson. Those, particularly, made by him on the subject of the strength of columns, and the most suitable form of cast-iron beams to sustain a transversal strain, have supplied the engineer and architect with the most valuable guide in adapting this material to the various purposes of structures.

**348. Resistance to Extension.**—From a few experiments made by Mr. Rennie and Captain Brown, the tensile strength of cast iron varies from 7 to 9 tons per square inch.

The experiments of Mr. Hodgkinson upon both hot and cold blast iron give the tensile strength from 6 to  $9\frac{3}{4}$  tons per square inch.

From some experiments made on American cast iron, under the direction of the Franklin Institute, the mean tensile strength is 20834 lbs., or  $9\frac{1}{2}$  tons per square inch.

**349. Resistance to Compressive Strain.**—The general circumstances attending the rupture of this material by compression, drawn from the experiments of Mr. Hodgkinson, have already been given. The angle of the wedge resulting from the rupture is about  $55^\circ$ .

The mean crushing weight derived from experiments upon short cylinders of hot blast iron was 121,685 lbs., or 54 tons  $6\frac{1}{2}$  cwt. per square inch.

That on short prisms of the same, with square bases, 100,738 lbs., or 44 tons  $19\frac{1}{2}$  cwt. per square inch.

That on short cylinders of cold blast iron was 125,403 lbs., or 55 tons  $19\frac{1}{2}$  cwt. per square inch.

That on short prisms of the same, having other regular figures for their bases, was 100,631 lbs., or 44 tons  $18\frac{1}{2}$  cwt. per square inch.

Mr. Hodgkinson remarks with respect to the forms of base differing from the circle: "In the other forms the difference of strength is but little; and therefore we may perhaps admit that difference of form of section has no influence upon the power of a short prism to bear a crushing force."

In remarking on the circumstances attending the rupture, Mr. Hodgkinson further observes: "We may assume, therefore, without assignable error, that in the crushing of short

iron prisms of various forms, longer than the wedge, the angle of fracture will be the same. This simple assumption, if admitted, would prove at once, not only in this material, but in others which break in the same manner, the proportionality of the crushing force in different forms to the area; since the area of fracture would always be equal to the direct transverse area multiplied by a constant quantity dependent upon the material."

*Table exhibiting the Ratio of the Tensile to the Compressive Forces in Cast Iron, from Mr. Hodgkinson's Experiments.*

DESCRIPTION OF METAL.		Compressive force per square inch.	Tensile force per square inch.	Ratio.
Devon iron,	No. 3. Hot blast	145,435	21,907	6.638 : 1
Buffery iron,	No. 1. Hot blast	86,397	13,434	6.431 : 1
Do.	" Cold blast	93,385	17,466	5.346 : 1
Coed-Talen iron,	No. 2. Hot blast	82,734	16,676	4.961 : 1
Do.	" Cold blast	81,770	18,855	4.337 : 1
Carron iron,	No. 2. Hot blast	108,540	13,505	8.037 : 1
Do.	" Cold blast	106,375	16,683	6.376 : 1
Carron iron,	No. 3. Hot blast	133,440	17,755	7.515 : 1
Do.	" Cold blast	115,442	14,200	8.129 : 1

**350. Resistance of Cylindrical Columns.** The experiments under this head were made upon solid and hollow columns, both ends of which were either flat or rounded, fixed or loose, or one end flat and the other rounded. In the case of columns with rounded ends, the pressure was applied in the direction of the axis of the column.

The following extracts are made from Dr. Hodgkinson's paper on this subject, published in the *Report of the British Association of 1840*.

"1st. In all long pillars of the same dimensions, the resistance to crushing by flexure is about three times greater when the ends of the pillars are flat than when they are rounded.

"2d. The strength of a pillar, with one end rounded and the other flat, is the arithmetical mean between that of a pillar of the same dimensions with both ends round, and one with both ends flat. Thus, of three cylindrical pillars, all of the same length and diameter, the first having both its ends rounded, the second with one end rounded and one flat, and the third with both ends flat, the strengths are as 1, 2, 3, nearly.

"3d. A long, uniform, cast-iron pillar, with its ends firmly fixed, whether by means of disks or otherwise, has the same power to resist breaking as a pillar of the same diameter, and half the length, with the ends rounded or turned so that the force would pass through the axis.

"4th. The experiments show that some additional strength is given to a pillar by enlarging its diameter in the middle part; this increase does not, however, appear to be more than one seventh or one eighth of the breaking weight.

"5th. The index of the power of the diameter to which the strength of long pillars with rounded ends is proportional, is 3.76 nearly, and 3.55 in those with flat ends, as appeared from the results of a great number of experiments; or the strength of both may be taken as the 3.6 power of the diameter nearly.

"6th. In pillars of the same thickness, the strength is inversely proportional to the 1.7 power of the length nearly.

"Thus the strength of a solid pillar with rounded ends, the diameter of which is  $d$ , and the length  $l$ , is as  $\frac{d^{3.6}}{l^{1.7}}$ "

"The absolute strength of solid pillars, as appeared from the experiments, are nearly as below.

"In pillars with rounded ends,

$$\text{Strength in tons} = 14.9 \frac{d^{3.6}}{l^{1.7}}.$$

"In pillars with flat ends,

$$\text{Strength in tons} = 44.16 \frac{d^{3.6}}{l^{1.7}}.$$

"In hollow pillars nearly the same laws were found to obtain; thus, if  $D$  and  $d$  be the external and internal diameters of a pillar whose length is  $l$ , the strength of a hollow cylinder of which the ends were movable (as in the connecting-rod of a steam-engine) would be expressed by the formula below.

$$\text{Strength in tons} = 13 \frac{D^{3.6} - d^{3.6}}{l^{1.7}}.$$

"In hollow pillars, whose ends are flat, we had from experiment as before,

$$\text{Strength in tons} = 44.3 \frac{D^{3.6} - d^{3.6}}{l^{1.7}}.$$

"The formulæ above apply to all pillars whose length is not less than about thirty times the external diameter; for pillars shorter than this, it is necessary to have recourse to the 'formula,' given under the head of STRENGTH OF TIMBER, for

short pillars of timber, substituting for  $W$  and  $W'$  in that formula, the proper values applicable to cast-iron."

**351. Similar Pillars.** "In similar pillars, or those whose length is to the diameter in a constant proportion, the strength is nearly as the square of the diameter, or of any other linear dimension; or, in other words, the strength is nearly as the area of the transverse section."

"In hollow pillars, of greater diameter at one end than the other, or in the middle than at the ends, it was not found that any additional strength was obtained over that of cylindrical pillars."

"The strength of a pillar, in the form of the connecting rod of a steam-engine" (that is, the transverse section presenting the figure of a cross  $+$ ) "was found to be very small, perhaps not half the strength that the same metal would have given if cast in the form of a uniform hollow cylinder."

"A pillar irregularly fixed, so that the pressure would be in the direction of the diagonal, is reduced to one third of its strength. Pillars fixed at one end and movable at the other, as in those flat at one end and rounded at the other, break at one third the length from the movable end; therefore, to economize the metal, they should be rendered stronger there than in other parts."

**352. Long-continued Pressure on Pillars.** "To determine the effect of a load lying constantly on a pillar, Mr. Fairbairn had, at the writer's suggestion, four pillars cast, all of the same length and diameter. The first was loaded with 4 cwt., the second with 7 cwt., the third with 10 cwt., and the fourth with 13 cwt.; this last load was  $\frac{9}{10}$  of what had previously broken a pillar of the same dimensions, when the weight was carefully laid on without loss of time. The pillar loaded with 13 cwt. bore the weight between five and six months, and then broke."

**353. General Properties of Pillars.** "In pillars of wrought-iron, steel, and timber, the same laws, with respect to rounded and flat ends, were found to obtain, as had been shown to exist in cast-iron."

"Of rectangular pillars of timber, it was proved experimentally that the pillar of greatest strength of the same material, is a square."

**354. Comparative Strength of Cast-Iron, Wrought-Iron, Steel, and Timber.** "It resulted from the experiments upon pillars of the same dimensions but of different materials, that if we call the strength of cast-iron 1000, we

shall have for wrought 1745, cast steel 2518, Dantzic oak 108.8, red deal 78.5."

355. Resistance to Transverse Strain. The following tables and deductions are drawn from the experiments of Messrs. Hodgkinson and Fairbairn, on hot and cold blast iron, as published in their *Reports to the British Association in 1837*.

*Table exhibiting the results of experiments by Mr. Hodgkinson on bars of hot blast iron 5 feet long, with a rectangular sectional area; the bars resting horizontally on props 4 feet 6 inches apart; the weight being applied at the middle of the bar.*

EXPERIMENT 1.			EXPERIMENT 13.			EXPERIMENT 14.		
Rectangular bar, 1.00 inch broad, 1.00 " deep. Weight of bar, 15 lbs. 2 oz.			Rectangular bar, 1.03 inches broad, 3.00 " deep.			Rectangular bar, 1.02 inches broad, 4.98 " deep. Weight 78 lbs.		
Weight in lbs.	Deflection in inches.	Set, or deflection when unloaded.	Weight in lbs.	Deflection in inches.	Set in inches.	Weight in lbs.	Deflection in inches.	Set in inches.
16	.037	visible	1474	-	.001	5867	.127	-
23	.052	increased	1605	.130	.003	6798	.153	.01
30	.070	.001 ?	1866	.156	.006	7730	.177	-
56	.132	.002	2126	.185	.010	8661	.207	-
112	.271	.008	2388	.212	.012	9593	.235	-
224	.588	.037	2649	.243	.017	10524	.275	.03
336	.940	.087	2910	.272	.022	11087	broke	-
448	1.360	.181	3172	.307	.030	-	-	-
469	broke	-	3433	.340	.038	-	-	-
-	-	-	3694	.378	.050	-	-	-
-	-	-	3956	broke	-	-	-	-
Ultimate deflection 1.444 inches.			Ultimate deflection .416 inch.			Ultimate deflection .290 inch.		

356. The following remarks are extracted from the same Report: "I had remarked, in some of the experiments, that the elasticity of the bars was injured much earlier than is generally conceived; and that instead of its remaining perfect till one third, or upwards, of the breaking weight was laid on, as is generally admitted by writers, it was evident that  $\frac{1}{3}$ th, or less, produced in some cases a considerable set or defect of elasticity; and judging from its slow increase after

*Results of experiments, by the same, on the Transverse Strength of Cold Blast Iron; length of bars, and distance between the points of support the same as in the preceding table.*

EXPERIMENT 1.			EXPERIMENT 12.			EXPERIMENT 13.		
Rectangular bar, 1.025 inch deep, 1.002 " broad. Weight, 15 lbs. 6 oz.			Rectangular bar, 3.00 inches deep, 1.02 " broad. Weight, 46 lbs. 8 oz.			Rectangular bar, 4.98 inches deep, 1.03 " broad. Weight, 78 lbs.		
Weight in lbs.	Deflection in inches.	Set in inches.	Weight in lbs.	Deflection in inches.	Set in inches.	Weight in lbs.	Deflection in inches.	Set in inches.
16	.033	visible	1082	.091	.003	4936	.110	.013
30	.062	increased	1343	.111	.006	5887	.130	—
56	.120	.002	1605	.138	.008	6798	.153	.020
112	.240	.007	1866	.164	.010	7730	.179	.025
168	.370	.014	2126	.190	.012	8662	.195	—
224	.510	.028	2388	.229	.015	9593	.219	.034
280	.649	.041	2649	.250	.019	10525	.250	.042
336	.798	.061	2910	.281	.026	10588	broke	—
392	.953	.084	3172	.310	.031	—	—	—
448	1.120	.120	3433	.345	.037	—	—	—
504	1.310	.170	3694	.378	.046	—	—	—
514	it bore	—	3825	broke	—	—	—	—
518	broke	—	—	—	—	—	—	—
Ultimate deflection 1.36 inch.			Ultimate deflection 0.395 inch.			Ultimate deflection 0.332.		

wards, I was persuaded that it had not come on by a sudden change, but had existed, though in a less degree, from a very early period."

"From what has been stated above, deduced from experiments made with great care, it is evident that the maxim of loading bodies within the elastic limit has no foundation in nature; but it will be considered as a compensating fact, that materials will bear for an indefinite period a much greater load than has hitherto been conceived."

357. "We may admit," from the mean results, "that the strength of rectangular bars is as the square of the depth."

358. **Effects of Time upon the Deflections caused by a Permanent Load on the Middle of Horizontal Bars.** The following table exhibits the results of Mr. Fairbairn's experiments on this point. The experiments were made on

bars 5 feet long, 1.05 inch deep; the one of cold blast iron, 1.03 inch broad; the other of hot blast, 1.01 broad; distance between the points of support 4 feet 6 inches. The constant weight suspended at the centre of the bars was 280 lbs. This weight remained on from March 11th, 1837, to June 23d, 1838.

Cold blast iron. Deflection in inches.	Date of observation.	Temp.	Hot blast iron. Deflection in inches.	Ratio of increase of deflections.
.930	March 11th, 1837,	-	1.064	—
.963	June 23d, 1838.	78°	1.107	—
.083	Increase,	-	.043	1000 : 1303

359. Mr. Fairbairn in his Report remarks on the above and like results: "The hot blast bar in these experiments being more deflected than the cold blast, indicates that the particles are more extended and compressed in the former iron, with the same weight, than in the latter. This excess of deflection may in some degree account for the rapidity of increase, which it will be observed is considerably greater in the hot than in the cold blast bar."

"It appears from the present state of the bars (which indicate a slow but progressive increase in the deflections) that we must at some period arrive at a point beyond their bearing powers; or otherwise to that position which indicates a correct adjustment of the particles in equilibrium with the load. Which of the two points we have in this instance attained is difficult to determine; sufficient data, however, are adduced to show that the weights are considerably beyond the elastic limit, and that cast iron will support loads to an extent beyond what has usually been considered safe, or beyond that point where a permanent set takes place."

360. **Effects of Temperature.** Mr. Fairbairn remarks: "The infusion of heat into a metallic substance may render it more ductile, and probably less rigid in its nature; and I apprehend it will be found weaker, and less secure under the effects of heavy strain. This is observable to a considerable extent in the experiments" on transverse strength "ranging from 26° up to 190° Fahr."

"The cold blast at 26° and 190°, is in strength as 874 : 743. The hot blast at 26° and 190°, is in strength as 811 : 731



Being a diminution in strength as 100 : 85 for the cold blast, and 100 to 90 for the hot blast, or 15 per cent. loss of strength in the cold blast, and ten per cent. in the hot blast."



"A number of the experiments made on No. 3 iron have given extraordinary and not unfrequently unexpected results. Generally speaking, it is an iron of an irregular character, and presents less uniformity in its texture than either the first or second qualities; in other respects it is more retentive, and is often used for giving strength and tenacity to the finer metals."

"At 212° we have in the No. 3 a much greater weight sustained than what is indicated by the No. 2 at 190°; and at 600° there appears in both hot and cold blast the anomaly of increased strength as the temperature is advanced from boiling water to melted lead, arising from the greater strength of the No. 3 iron."

361. From experiments made by Major Wade on American cast iron, and by Mr. Fairbairn on English cast iron, it appears that the tenacity of the metal is increased both by remelting, and by prolonged fusion when kept in their certain limits. It also appears from other experiments that repeated fusions occasion a heavy waste of material, and that if either remelting or prolonged fusion be carried too far the result will be an iron of a hard and brittle quality.

362. **Influence of Form upon the Transverse Strength of Cast Iron Beams.** Upon no point, respecting the strength of cast iron, have the experiments of Mr. Hodgkinson led to more valuable results to the engineer and architect, than upon the one under this head. The following tables give the results of experiments on bars of a uniform cross-section (thus **T**) cast from hot and cold blast iron. The bars were 7 feet long, and placed, for breaking, on supports 6 feet 6 inches asunder.

*Table exhibiting the Results of Experiments on Bars of Hot Blast Iron of the form of cross section as above.*

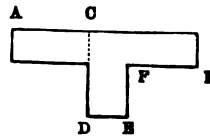

EXPERIMENT 4.			EXPERIMENT 5.		
Bar broken  as shown with the rib downward.			Bar broken  as shown with the rib upward.		
Weight in lbs.	Deflection in inches.	Set.	Weight in lbs.	Deflection in inches.	Set.
7	.015	visible	7	-	not visible
14	.032	.001	14	.025	visible
21	.046	.002	21	.045	.002
28	.064	.004	28	.065	.003
56	.130	.005	56	.124	.005
112	.273	.020	112	.270	.015
168	.444	.035	224	.580	.058
224	.618	.058	336	.895	.101
280	.818	.098	448	1.224	.155
336	1.030	.130	560	1.585	.235
364	broke	-	672	1.985	.330
-	-	-	784	2.410	.490
-	-	-	896	3.450	.722
-	-	-	1008	4.140	1.040
-	-	-	1064	-	-
-	-	-	1120	broke	-
Ultimate deflection 1.138 inches.			Fracture caused by a wedge 2.92 inches long and 1.05 deep, of this form flying out. 		
			Ultimate deflection 4.830.		

*Note.* The annexed diagram shows the form of the uniform cross-section of the bars. The linear dimensions of the cross-section in the two experiments were as follows:—



Length of parallelogram AB	5 inches	} Expt. 4. } Expt. 5.
Depth " AB	0.30 "	
Total depth of bar..... CD	1.55 "	
Breadth of rib..... DE	0.36 "	
		..... 5 inches
		..... 0.30 "
		..... 1.56 "
		..... 0.365 "

Table exhibiting Results of Experiments on bars of Cold Blast Iron 5 feet long, of the same form of cross section as in preceding table.

EXPERIMENT 4.			EXPERIMENT 5.		
Bar broken  with rib downward.			Bar broken  with rib upward.		
Weight in lbs.	Deflection in inches.	Set.	Weight in lbs.	Deflection in inches.	Set.
112	.08	-	112	.03	-
224	.07	-	224	.07	-
336	.11	-	336	.11	-
392	.18	.005	448	.15	-
490	.14	.007	560	.19	.005
448	.15	.010	616	.21	.010
560	.19	.012	672	.23	-
672	.23	.015	728	-	.015
784	.28	.023	784	.27	-
896	.33	.030	896	.31	-
952	.35	-	1008	.35	-
980	broke	-	1120	.39	-
-	-	-	1344	.48	-
-	-	-	1568	.57	-
-	-	-	1792	.67	-
-	-	-	2016	.80	-
-	-	-	2240	.95	-
-	-	-	2396	it bore	-
-	-	-	2352	broke	-
Ultimate deflection .36.			Ultimate deflection 1.03.		
			Fracture by a wedge breaking out as in Experiment 5, Hot Blast.		

*Note.* The linear dimensions of the cross-section of the bars in the above table were nearly the same as those in the preceding table, with the exception of the total depth CD, which in these last two experiments was 2.27 inches, or a little more.

363. The object had in view by Mr. Hodgkinson, in the experiments recorded in the two preceding tables, was two-fold; the one to ascertain the circumstances under which a permanent set, or injury to elasticity takes place; the other to ascertain the effect of the form of cross section on the transverse strength of cast iron. The following extracts from the Report, give the principal deductions of Mr. Hodgkinson on these points.

“In experiments 4 and 5” (on hot blast iron), “which were

on longer bars than the others, cast for this purpose, and for another mentioned further on, the elasticity (in Expt. 4) was sensibly injured with 7 lbs., and in the latter (Expt. 5) with 14 lbs., the breaking weights being 364 lbs., and 1120 lbs. In the former of these cases a set was visible with  $\frac{1}{8}$ , and in the other with  $\frac{1}{16}$  of the breaking weight, showing that there is no weight, however small, that will not injure the elasticity."

"When a body is subjected to a transverse strain, some of its particles are extended and others compressed; I was desirous to ascertain whether the above defect in elasticity arose from tension or compression, or both. Experiments 4 and 5 show this; in these a section of the casting, which was uniform throughout, had the form . During the experiments the broad part  $ab$  was laid horizontally upon supports; the vertical rib  $c$  in the latter experiment being upward, in the former downward. When it was downward the rib was extended, when upward the rib was compressed. In both cases the part  $ab$  was the fulcrum; it was thin, and therefore easily flexible; but its breadth was such that it was nearly inextensible and incompressible, comparatively, with the vertical rib. We may therefore assume, that nearly the whole flexure which takes place in a bar of this form, arises from the extension or compression of the rib, according as it is downward or upward. In Expt. 4 we have extension nearly without compression, and in Expt. 5 compression almost without extension. These experiments were made with great care. They show that there is but little difference in the quantity of set, whether it arises from tension or compression."

"The set from compression, however, is usually less than that from extension, as is seen in the commencement of the two experiments, and near the time of fracture in that submitted to tension. The deflections from equal weights are nearly the same whether the rib be extended or compressed, but the ultimate strengths, as appears from above, are widely different."

**364. Form of Cast Iron Beam best adapted to Resist a Transverse Strain.** The experiments of Mr. Hodgkinson on this subject, published in the *Memoirs of the Literary and Philosophical Society of Manchester, Second Series*, vol. 5, are of equal interest with those just detailed, both in their general results and practical bearing. From these experiments, the conclusion drawn is that the form of beam in the

annexed diagrams is the most favorable for resistance to transverse strains.

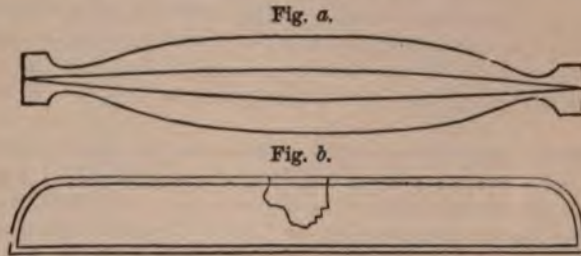

Fig. *a* represents the plan, Fig. *b* the elevation, and Fig. *c* the cross section (enlarged) at the middle of the beam. From the Figs. it will be seen that the beam consists of three parts; a bottom flanch of uniform depth, but variable breadth, tapering from the centre towards the extremities, where the points of support would be placed so as to form a portion of the common parabola on each side of the axis of the beam, the vertex of each parabola being at the centre of the beam. The object of this form of flanch was to make it, according to theory, the strongest, with the same amount of material, to bear a weight uniformly distributed over it. The top flanch is of a like form, but of much smaller breadth and depth than the bottom one. The two are united by a vertical rib of uniform depth and breadth.

The following are the relative dimensions of this form of beam, which, from experiment, gave the most favorable result.

Distance of supports.....	4 ft. 6 inches.
Total depth of beam.....	0 " 5½ "
Breadth of top flanch at centre of beam.....	2.33 "
"    bottom flanch    ".....	6.66 "
Uniform depth of top flanch.....	0.31 "
"    bottom flanch.....	0.66 "
Thickness of vertical rib.....	0.266 "
Total area of cross section.....	6.4 square inch.
Weight of beam.....	71 lbs.

"This beam broke in the middle by compression with 26084 lbs., or 11 tons 13 cwt., a wedge separating from its upper side."

"The weights were laid gradually and slowly on, and the beam had borne within a little of its breaking weight a considerable time, perhaps half an hour."

"The form of the fracture and wedge is represented in the Fig. *b*, where *enf* is the wedge, *ef*=5.1 inches, *tn*=3.9 inches, angle *enf*=82°."

"It is extremely probable, from this fracture, that the neutral point was at *n*, the vertex of the wedge, and therefore at  $\frac{1}{4}$ th the depth of the beam, since  $3.9 = \frac{3}{4} \times 5\frac{1}{4}$  nearly."

The relative dimensions above given were arrived at by "constantly making small additions" to the bottom flanch, until a point was reached where resistance to compression could no longer be sustained. The beams of this form, in all previous experiments, having yielded by the bottom flanch tearing asunder.

"The great strength of this form of cross section is an indisputable refutation of that theory which would make the top and bottom ribs of a cast iron beam equal."

"The form of cross section" (as above) "is the best which we have arrived at for the beam to bear an ultimate strain. If we adopt the form of beam (as above) I think we may confidently expect to obtain the same strength with a saving of upwards of  $\frac{1}{4}$ th of the metal."

365. *Rules for determining the Ultimate Strength of Cast Iron Beams of the above Forms.* From the results of his experiments, Mr. Hodgkinson has deduced the following very simple formulæ, for determining the breaking weight, in tons, when applied at the middle of a beam.

Call the breaking weight in tons, *W*.

Call the area of the cross section of the bottom flanch, taken at the middle of the beam, *a*.

Call the depth of the beam at the middle point, *d*.

Call the distance between the supports, *l*.

Then

$$W = 26 \frac{ad}{l},$$

when the beam has been cast with the bottom flanch upward and

$$W = 24 \frac{ad}{l},$$

when the beam has been cast on its side.

The working strain on cast iron beams subjected to direct compression is placed by most authorities at from  $\frac{1}{4}$ th to  $\frac{1}{3}$ th of the crushing weight, when the beam, a column for exam-

ple, is not subjected to violent vibrations or shocks. In the contrary case, particularly in beams subjected to a transverse strain, it is recommended to reduce the working strain to  $\frac{1}{10}$ th the crushing strain.

**366. Effect of Horizontal Impact upon Cast Iron Bars.** The following tables of experiments on this subject, and the results drawn from them, are taken from a paper by Mr. Hodgkinson, published in the *Fifth Report of the British Association*.

The bars under experiment were impinged upon by a weight suspended freely in such a position that, hanging vertically, it was in contact with the side of the bar. The blow was given by allowing the weight to swing through different arcs. The bars were so confined against lateral supports, that they could take no vertical motion.

*Table of experiments on a cast iron bar, 4 ft. 6 in. long, 1 in. broad,  $\frac{1}{2}$  in. thick, weighing  $7\frac{1}{2}$  lbs., placed with the broad-side against lateral supports 4 ft. asunder, and impinged upon by cast iron and lead balls weighing  $8\frac{1}{2}$  lbs., swinging through arcs of the radius 12 feet.*

Impact with leaden ball.			Impact with iron ball.		
Chord of arc fallen through in feet.	Unversed chord of recoil of ball in inches.	Observed deflection of bar in inches.	Chord of arc fallen through in feet.	Unversed chord of recoil of ball in inches.	Observed deflection of bar in inches.
1	6.5	.24	1	6.5	.23
2	13	.46	2	14	.46
3	19	.73	3	20	.65
4	27	.97	4	29	.98
5	34	1.30	5	37	1.32
6	47	1.60	6	48	1.65

“Before the experiments on impact were made upon this bar, it was laid on two horizontal supports 4 feet asunder, and weights gently laid on the middle bent it (in the same direction that it was afterwards bent by impact) as below:

28 lbs. bent it .37 inch.  
56 lbs. “ .77 inch. Elasticity a little injured.”

Table of experiments on a cast iron bar 7 ft. long, 1.08 in. broad and 1.05 in. thick, weighing  $23\frac{1}{2}$  lbs., placed, as in preceding experiments, against supports 6 ft. 6 in. asunder, and bent by impacts in the middle. Impinging ball of cast iron weighing  $20\frac{3}{4}$  lbs. Radius of arcs 16 feet.

Impact upon bar.		Impact upon the weight.	
Chord of arc fallen through.	Observed deflection in inches.	Chord of arc fallen through.	Observed deflection in inches.
2	.46	2	.31
3	.62	3	.43
4	.87	4	.69
5	1.03	5	.81
6	1.24	6	1.04
7	1.44	7	1.28
8	1.80	8	1.41
-	-	9	1.63

The results in the 3d and 4th columns of the above table were derived from allowing the ball to impinge against a weight of 56 lbs., hung so as to be in contact with the bar.

"Before the experiments on impact, the beam was laid on two supports 6 ft. 6 in. asunder, and was bent .78 in. by 123 lbs. (including the pressure from its own weight), applied gently in the middle."

Tables of experiments on two cast iron bars, 4 ft. 6 in. long, full inch square, weighing 14 lbs. 10 oz. nearly, placed against supports 4 feet apart, and impinged upon by a cast iron ball weighing 44 lbs. Radius 16 ft.

Impact in the middle.		Impact at one-fourth the length from the middle of the bars.		
Chords of arcs in feet.	Mean deflections of the two bars in inches.	Chords of arcs in feet.	Mean deflections of the two bars in inches.	Mean ratio of the deflections in the two cases.
2	.35	2	.24	-
3	.55	3	.42	-
4	.77	4	.52	.694
5	.95	5	.64	-
5.5	1.05	5.5	.70	-
6	Broke in the middle	6	Broke at the point of impact	-



The results in the 1st of the above tables are from bars struck in the middle, those in the 2d table are from bars struck at the middle point between the centre and extremity of the bar.

From the above and other experiments the conclusion is drawn, "that a uniform beam will bear the same blow, whether struck in the middle or half way between that and one end."

"From all the experiments it appears that the deflection is nearly as the chord of the arc fallen through, or as the velocity of impact."

The following conclusions are drawn from the experiments.

(1.) "If different bodies of equal weight, but differing considerably in hardness and elastic force, be made to strike horizontally against the middle of a heavy beam supported at its ends, all the bodies will recoil with velocities equal to one another."

(2.) "If, as before, a beam supported at its ends be struck horizontally by bodies of the same weight, but different hardness and elastic force, the deflection of the beam will be the same whichever body be used."

(3.) "The quantity of recoil in a body, after striking against a beam as above, is nearly equal to (though somewhat below) what would arise from the full varying pressure of a perfectly elastic beam, as it recovered its form after deflection."

*Note.* This last conclusion is drawn from a comparison of the results of experiment with those obtained from calculation, in which the beam is assumed as perfectly elastic.

(4.) "The effect of bodies of different natures striking against a hard, flexible beam, seems to be independent of the elasticities of the bodies, and may be calculated, with trifling error, on a supposition that they are inelastic."

(5.) "The power of a uniform beam to resist a blow given horizontally, is the same in whatever part it is struck."

367. From the results of the experiments of Messrs. Fairbairn and Hodgkinson, on the properties of cold and hot blast iron, it appears that the ratio of their resistances to impact is 1000 to 1226.3, the resistance of cold blast being represented by 1000: the resistance, or power of the beam to bear a horizontal impact, being measured by the product of its breaking weight from a transverse strain at the middle of the beam and its ultimate deflection. This measure, Mr. Hodgkinson remarks, "supposes that all cast iron bars of the same dimensions, in our experiments, are of the same weight, and that the deflection of a beam up to the breaking weight would be

as the pressure. Neither of these is true; they are only approximations; but the difference in the weights of cast iron bars of equal size is very little, and, taking them as the same, it may be inferred from my paper on Impact upon Beams (*Fifth Report of the British Association*) that the assumption above gives results near enough for practice."

---

## VI.

### STRENGTH OF WROUGHT IRON.

THIS material, from its very extensive applications in structures where a considerable tensile force is to be resisted, as in suspension bridges, iron ties, etc., has been the subject of a very great number of experiments. Among the many may be cited those of Telford and Brown in England, Duleau in France, and the able and extensive series upon plate iron for steam boilers, made under the direction of the Franklin Institute, and published in the 19th and 20th vols. (*New Series*) of the *Journal of the Institute*.

**368. Resistance to Tensile Strain.** The tables on the next page exhibit the tensile strength of this material under ordinary temperatures, and in the different states in which it is used for structures.

It is remarked, in the Report of the Sub-committee, "that the inherent irregularities of the metal, even in the best specimens, whether of rolled or hammered iron, seldom fall short of 10 or 15 per cent. of the mean strength."

From the same series of experiments, it appears that the strength of rolled plate lengthwise is about 6 per cent. greater than its strength crosswise.

In the *Tenth Report of the British Association* in 1840, Mr. Fairbairn has given the results of experiments on plate iron by Mr Hodgkinson, from which it appears that the mean strength of iron plates lengthwise is 22.52 tons.

Crosswise " 23.04 "

Single-rieveted plates " 18,590 lbs.

Double-rieveted plates " 22,258 "

Representing the strength of the plate by 100.

The double-rieveted plates will be . . . . . 70.

The single-rieveted plates will be . . . . . 56.

Table exhibiting the Strength of Square and Round Bars of Wrought Iron.

DESCRIPTION OF IRON.	Length of pieces in feet.	Extension before rupture in inches.	Breaking weight in tons.	Tensile strength per square inch.	Author.
Bar 1 inch square, <i>Welsh</i> .....	1	22.75	29	29	Telford.
" " <i>Swedish</i> .....	1	0.375	29	29	"
Round bar, 2 in. diam. ".....	1	2.2	100	29.98	"
Bar, 1.31 inch square ".....	3.5	0.19	40.95	23.75	Brown.
" 1.19 " ".....	3.5	3.00	33.50	23.75	"
Round bar, 1.31 in. diam., <i>Russian</i>	3.5	2.25	36.10	26.50	"
Bar, 1.25 inch square, <i>Welsh</i> .....	3.5	2.00	38.05	24.35	"
Round bar, 2 in. diam. ".....	12.5	18.50	82.75	26.33	"
Bars reduced in the middle by hammering to 0.375 in. square	....	....	....	31.35	Brunel.
" " 0.50 ".....	....	....	....	30.80	"
Bar, <i>Missouri</i> .....	....	....	....	21.28	} Franklin Institute.
" (dit rods).....	....	....	....	22.33	
" <i>Tennessee</i> .....	....	....	....	23.25	"
" <i>Salisbury, Connecticut</i> .....	....	....	....	25.89	"
" <i>Swedish</i> .....	....	....	....	25.97	"
" <i>Centre Co., Penn.</i> .....	....	....	....	26.07	"
" <i>Lancaster Co., Penn.</i> .....	....	....	....	26.18	"
" (cable iron) <i>English</i> .....	....	....	....	26.62	"
do. hammer-hardened ".....	....	....	....	31.70	"
" <i>Russian</i> .....	....	....	....	33.95	"
Wire, 0.333 in. diam. <i>Phillipsburg</i>	....	....	....	37.58	"
" 0.190 " ".....	....	....	....	32.98	"
" 0.166 " ".....	....	....	....	39.80	"
" 0.10 " <i>English</i> .....	....	....	....	35.81	Telford.

Table exhibiting the Mean Strength of Boiler Iron, per square inch in lbs., cut from plates with shears.

Process of manufacture.	Rough edge bar.	Edges filed un- formly.	Notches filed into bar on each edge.
Piled iron.....	53,045	56,081	63,266
Hammered plate.....	47,506	55,584	58,447
Puddled iron.....	52,341	51,039	62,420

Professor Barlow, in his *Report to the Directors of the London and Birmingham Railroad* (Journal of Franklin Institute, July, 1835), states, as the results of his experiments, that a bar of malleable iron one inch square is elongated the  $\frac{1}{10,000}$ th part of its length by a strain of one ton; that good iron is elongated the  $\frac{1}{10,000}$ th part by a strain of 10 tons, and is injured by this strain, while indifferent or bad iron is injured by a strain of 8 tons.

From the Report made to the Franklin Institute, it appears that the first set, or permanent, elongation, may take place under very different strains, varying with the character of the material. The most ductile iron yields permanently to a low

degree of strain. The extremes by which a permanent set is given vary between the 0.416 and 0.872 of the ultimate strength; the mean of thirteen comparisons being 0.641.

From the able series of experiments made by Mr. Kirkaldy at Glasgow, on the tensile strength of wrought iron, he has arrived at the following general conclusions (*Kirkaldy, Experiments on Wrought Iron and Steel, 2d Ed., 1866*):—

1. The breaking strain does *not* indicate the quality, as hitherto assumed.

2. A *high* breaking strain may be due to the iron being of superior quality, dense, fine, and moderately soft, or simply to its being very hard and unyielding.

3. A *low* breaking strain may be due to looseness and coarseness in the texture, or to extreme softness, although very close and fine in quality.

4. The contraction of area at fracture, previously overlooked, forms an essential element in estimating the quality of specimens.

5. The respective merits of various specimens can be correctly ascertained by comparing the breaking strain *jointly* with the contraction of area.

6. Inferior qualities show a much greater variation in the breaking strain than superior.

7. Greater differences exist between small and large bars in coarse than in fine varieties.

8. The prevailing opinion of a rough bar being stronger than a turned one is erroneous.

9. Rolled bars are slightly hardened by being forged down.

10. The breaking strain and contraction of area of iron plates are greater in the direction in which they are rolled than in a transverse direction.

11. A very slight difference exists between specimens from the centre and specimens from the outside of crank-shafts.

12. The breaking strain and contraction of area are greater in those specimens cut lengthways out of crank-shafts than in those cut crossways.

13. Iron, when fractured suddenly, presents invariably a crystalline appearance; when fractured slowly, its appearance is invariably fibrous.

14. The appearance may be changed from fibrous to crystalline by merely altering the shape of specimen so as to render it more liable to snap.

15. The appearance may be changed by varying the treatment so as to render the iron harder and more liable to snap

16. The appearance may be changed by applying the strain so suddenly as to render the specimen more liable to snap, from having less time to stretch.

17. Iron is less liable to snap the more it is worked and rolled.

18. The "skin," or outer part of the iron, is somewhat harder than the inner part, as shown by appearance of fracture in rough and turned bars.

19. The mixed character of the scrap-iron used in large forgings is proved by the singularly varied appearance of the fractures of specimens cut out of crank-shafts.

20. The texture of various kinds of wrought iron is beautifully developed by immersion in dilute hydrochloric acid, which, acting on the surrounding impurities, exposes the metallic portion alone for examination.

21. In the fibrous fractures the threads are drawn out, and are viewed externally, whilst in the crystalline fractures the threads are snapped across in clusters, and are viewed internally or sectionally. In the latter cases the fracture of the specimen is always at right angles to the length; in the former it is more or less irregular; fracture is nearly free of lustre and unlike the crystalline appearance of iron suddenly fractured; the two, combined in the same specimen, are shown in iron bolts partly converted into steel.

22. The little additional time required in testing those specimens whose rate of elongation was noted had no injurious effect in lessening the amount of breaking strain, as imagined by some.

23. The rate of elongation varies not only extremely in different qualities, but also to a considerable extent in specimens of the same brand.

24. The specimens were generally found to stretch equally throughout their length until close upon rupture, when they more or less suddenly drew out, usually at one part only, sometimes at two, and, in a few exceptional cases, at three different places.

25. The ratio of ultimate elongation may be greater in short than in long bars in some descriptions of iron, whilst in others the ratio is not affected by difference in the length.

26. The lateral dimensions of specimens forms an important element in comparing either the rate of, or the ultimate elongations—a circumstance which has been hitherto overlooked.

27. Iron bolts, case-hardened, bore a less breaking strain

than when wholly iron, owing to the superior tenacity of the small proportion of steel being more than counterbalanced by the greater ductility of the remaining portion of iron.

28. Iron highly heated and suddenly cooled in water is hardened, and the breaking strain, when gradually applied, increased, but at the same time it is rendered more liable to snap.

29. Iron, like steel, is softened, and the breaking strain reduced by being heated and allowed to cool slowly.

30. Iron, subjected to the cold-rolling process, has its breaking strain greatly increased by being made extremely hard, and not by being "consolidated," as previously supposed.

31. Specimens cut out of crank-shaft are improved by additional hammering.

32. The galvanizing or tinning of iron plates produces no sensible effects on plates of the thickness experimented on. The results, however, may be different should the plates be extremely thin.

33. The breaking strain is materially affected by the shape of the specimen. Thus the amount borne was much less when the diameter was uniform for some inches of the length than when confined to a small portion—a peculiarity previously unascertained and not even suspected.

34. It is necessary to know correctly the exact conditions under which any tests are made, before we can equitably compare results obtained from different quarters.

35. The startling discrepancy between experiments made at the Royal Arsenal, and by the writer, is due to the difference in the shape of the respective specimens, and not to the difference in the two testing machines.

36. In screwed bolts the breaking strain is found to be greater when old dies are used in their formation than when the dies are new, owing to the iron becoming harder by the greater pressure required in forming the screw thread when the dies are old and blunt, than when new and sharp.

37. The strength of screw-bolts is found to be in proportion to their relative areas, there being only a slight difference in favor of the smaller compared with the larger sizes, instead of the very material difference previously imagined.

38. Screwed bolts are not necessarily injured although strained nearly to their breaking-point.

39. A great variation exists in the strength of iron bars which have been cut and welded; whilst some bear almost as

much as the uncit bar, the strength of others is reduced fully a third.

40. Iron is injured by being brought to a white or welding heat if not at the same time hammered or rolled.

41. The breaking strain is considerably less when the strain is applied suddenly instead of gradually, though some have imagined that the reverse is the case.

42. The contraction of area is also less when the strain is suddenly applied.

43. The breaking strain is reduced when the iron is frozen; with the strain gradually applied, the difference between a frozen and unfrozen bolt is lessened, as the iron is warmed by the drawing out of the specimen.

44. The amount of heat developed is considerable when the specimen is suddenly stretched, as shown in the formation of vapor from the melting of the layer of ice on one of the specimens, and also by the surface of others assuming tints of various shades of blue and orange, not only in steel, but also, although in a less marked degree, in iron.

45. The specific gravity is found generally to indicate pretty correctly the quality of specimens.

46. The density of iron is *decreased* by the process of wire-drawing, and by the similar process of cold-rolling, instead of *increased*, as previously imagined.

47. The density in some descriptions of iron is also decreased by additional hot-rolling in the ordinary way; in others the density is very slightly increased.

48. The density of iron is decreased by being drawn out under a tensile strain, instead of increased, as believed by some.

The breaking strain per square-inch of wrought iron is generally stated to be about twenty-five tons for bars, and twenty tons for plates. This corresponds very nearly with the results of the writer's experiments, of which the following table presents a condensed summary:—

	Highest, lbs.	Lowest, lbs.	Mean, lbs.	Tons.
188. Bars, rolled.....	68,848	44,584	57,555	=25½
72. Angle-iron, etc.....	63,715	37,909	54,729	=24½
167. Plates, lengthways.....	62,544	37,474	50,737	} =21½
160. Plates, crossways.....	60,756	32,450	46,171	

Although the *breaking* strain is generally assumed to be about twenty-five tons for bars, and twenty tons for plates, very great difference of opinion exists as to the amount of *working* strain, or the load which can with safety be applied

in actual practice. The latter is variously stated at from a third to a tenth. It will be observed that whilst much discussion has arisen as to the amount of working strain, or the ratio the load should bear to that of the breaking strain, the important circumstance of the *quality* of the iron, as influencing the working strain, has been overlooked. The Board of Trade limits the strain to 5 tons, or 11,200 lbs. per square inch.

It must be abundantly evident, from the facts which have been produced, that the breaking strain, when taken alone, gives a false impression of, instead of indicating, the real quality of the iron, as the experiments which have been instituted reveal the somewhat startling fact, that frequently the inferior kinds of iron actually yield a higher result than the superior. The reason of this difference was shown to be due to the fact that, whilst the one quality retained its original area, only very slightly decreased by the strain, the other was reduced to less than one-half. Now, surely this variation, hitherto unaccountably completely overlooked, is of importance as indicating the relative hardness or softness of the material, and thus, it is submitted, forms an essential element in considering the safe load that can be practically applied in various structures. It must be borne in mind that although the softness of the material has the effect of lessening the amount of the *breaking* strain, it has the very opposite effect as regards the *working* strain. This holds good for two reasons: first, the softer the iron the less liable it is to snap; and second, fine or soft iron, being more uniform in quality, can be more depended upon in practice. Hence the load which this description of iron can suspend with safety may approach much more nearly the limit of its breaking strain than can be attempted with the harder or coarser sorts, where a greater margin must necessarily be left.

Special attention is now solicited to the practical use that may be made of the new mode of comparison introduced by the writer, viz., the *breaking strain per square inch of the fractured area of the specimen, instead of the breaking strain per square inch of the original area.*

As a necessary corollary to what he has just endeavored to establish, the writer now submits, in addition, that the *working* strain should be in proportion to the breaking strain per square inch of fractured area, and not to the breaking strain per square inch of original area, as heretofore. He does not presume to say what that ratio should be, but he fully maintains that some kinds of iron experimented on by him will



sustain with safety more than double the load that others can suspend, especially in circumstances where the load is unsteady, and the structure exposed to concussions, as in a ship, or to vibratory action, as in a railway bridge.

**369. Resistance to Compressive Strain.** But few experiments have been published on the resistance of this material to compression. Rondelet states that it commences to yield under a pressure of about 70,800 lbs. per square inch, and that when the altitude of the specimen tried is greater than three times the diameter of the base it yields by bending. Mr. Hodgkinson states that the circumstances of its rupture from crushing indicate a law similar to what obtains in cast iron.

The same rule for proportioning the working strain to the crushing strain is followed in wrought iron subjected to compression as in cast iron.

**Resistance to a Transverse Strain.** The following tables exhibit the circumstances of deflection from a transverse strain on bars laid on horizontal supports; the weight being applied at the middle of the bar.

The table I. gives the results on bars 2 inches square, laid on supports 33 inches asunder; table II. the results on bars 2 inches deep, 1.9 in. broad, bearing as in table I.

TABLE I.

TABLE II.

Weight in tons.	Deflections in inches for each half ton.	Weight in tons.	Deflections in inches for each half ton.
.75	.020	.250	-
1.00	.020	.50	.016
1.50	.020	1.00	.022
2.00	.030	1.50	.020
2.50	.020	2.00	.028
3.00	Set	2.25	.018
-	-	2.50	.028
-	-	2.75	.038
-	-	3.00	.092

The above experiments were made by Professor Barlow, and published in his report already cited. He remarks on the results in Table II., that the elasticity was injured by 2.50 tons and destroyed by 3.00 tons.

**370.** Trials were made to ascertain mechanically the position of the neutral axis on the cross section. Professor Barlow remarks on these trials, that "the measurements obtained in these experiments being tension 1.6, compression 0.4, giv

ing exactly the ratio of 1 to 4 in rectangular bars. These results seem the most positive of any hitherto obtained; still there can be little doubt this ratio varies in iron of different qualities; but looking to the preceding experiments, it is probably always from 1 to 3, to 1 to 5."

**371. Effects of Time on the Elongation of Wrought Iron from a Constant Strain of Extension.** M. Vicat has given, in the *Annales de Chimie et de Physique*, vol. 54, some experiments on this point, made on iron wires which had not been annealed, by subjecting four wires, respectively, to strains amounting to the  $\frac{1}{4}$ , the  $\frac{1}{3}$ , the  $\frac{1}{2}$ , and  $\frac{2}{3}$  of their tensile strength, during a period of 33 months.

From the results of these experiments it appears, that each wire, immediately upon the application of the strain to which it was subjected, received a certain amount of extension.

The first wire, which was subjected to a strain of  $\frac{1}{4}$ th its tensile strength, was found at the end of the time in question not to have acquired any increase of extension.

The second, submitted to  $\frac{1}{3}$ d its tensile strength, was elongated 0.027 in. per foot, independently of the elongation it at first received.

The third, subjected under like circumstances to a strain of  $\frac{1}{2}$ th its tensile strength, was elongated 0.40 in. per foot, besides its first elongation.

The fourth, similarly subjected to  $\frac{2}{3}$ ths the tensile strength, was elongated 0.061, besides its first elongation.

From observations made during the experiments, it was found that, reckoning from the time when the first elongations took place, the rapidity of the subsequent elongations was nearly proportional to the times; and that the elongations from strains greater than  $\frac{1}{4}$ th the tensile strength are, after equal times, nearly proportional to the strains.

M. Vicat remarks in substance, upon the results of these experiments, that iron wire, when not annealed, commences to exhibit a permanent set when subjected to a strain between the  $\frac{1}{4}$  and  $\frac{1}{3}$  of its tensile strength, and that therefore it is rendered probable that the wire ropes of a suspension bridge, which should be subjected to a like strain, would, when the vibratory motion to which such structures are liable is considered, yield constantly from year to year, until they entirely gave way.

M. Vicat further remarks, in substance, that the measure of the resistance offered by materials to strains exerted only some minutes, or hours, is entirely relative to the duration of the experiments. To ascertain the absolute measure of this resistance, which should serve as a guide to the engineer, the

materials ought to be subjected for some months to strains ; while observations should be made during this period, with accurate instruments, upon the manner in which they yield under these strains.

*The following tables, on the comparative strength of iron, steel and hemp rope are taken from Stoney's work on the Theory of Strains, Vol. II. The weights are given in English units.*

HEMP.		IRON.		STEEL.		EQUIVALENT STRENGTH.	
Circumference, inches.	Lbs. weight pr. fathom.	Circumference, inches.	Lbs. weight pr. fathom.	Circumference, inches.	Lbs. weight pr. fathom.	Working load, cwt.	Tearing strain, tons.
2½	2	1	1	.....	.....	6	2
.....	.....	1½	1½	1	1	9	3
3½	4	1¾	2	.....	.....	12	4
.....	.....	1¾	2½	1½	1½	15	5
4½	5	1¾	3	.....	.....	18	6
.....	.....	2	3½	1¾	2	21	7
5½	7	2½	4	1¾	2½	24	8
.....	.....	2½	4½	.....	.....	27	9
6	9	2¾	5	1¾	3	30	10
.....	.....	2½	5½	.....	.....	33	11
6½	10	2¾	6	2	3½	36	12
.....	.....	2¾	6½	2½	4	39	13
7	12	2¾	7	2½	4½	42	14
.....	.....	3	7½	.....	.....	45	15
7½	14	3½	8	2¾	5	48	16
.....	.....	3½	8½	.....	.....	51	17
8	16	3¾	9	2½	5½	54	18
.....	.....	3½	10	2¾	6	60	20
8½	18	3¾	11	2¾	6½	66	22
.....	.....	3¾	12	.....	.....	72	24
9½	22	3¾	13	3½	8	78	26
10	26	4	14	.....	.....	84	28
.....	.....	4½	15	3¾	9	90	30
11	30	4¾	16	.....	.....	96	32
.....	.....	4½	18	3½	10	108	36
12	34	4¾	20	3½	12	120	40

RESSEMER STEEL, MADE FROM RAIL-ENDS BY MARSH & CO. NOT TEMPERED.

No.	Breaking strain.	Strength per square inch.	Feet in the lb.	Stretch.	Per cent. of length.	Length.	Drawn from.
6	3472	118,471	10.15	1½	2.4	5.0783	4-6.
6	3220	110,563	10.28	1½	1.3	4.975	4-6.
7	3038	114,549	11.21	1½	1.05	4.9063	4-7; large 7
7	3136	122,880	11.6	1½	1.8	5.1	4-7.
8	2135	109,034	15.2	1½	1.04	4.9844	4-8.
9	2184	127,000	17.3	1½	0.35	4.8646	4-6 and 6-9.
9	1904	109,770	17.14	1½	0.65	4.823	4-6 and 6-9.
10	1694	117,567	20.6	1½	1.2	4.8375	4-10 { no annealing
10	1610	111,718	20.6	1½	0.6	4.8375	4-10 } between hard drawn.
10	1834	130,493	21.16	1½	1	4.96	4-7 and 7-10 not drawn hard.
11	1407	121,900	25.7	1½	0.8	4.833	4-8 and 8-11 not drawn hard.
12	1015	121,679	32.6	1½	1.5	4.6094	4-7; 7-10 and 10-12.
13	952	131,055	40.9	1½	0.8	5.1106	4-7; 7-10 and 10-13.
14	630	114,508	54	1½	1.2	5.073	4-7; 7-10; 10-12 and 12-14.
15	560	170,740	62.5	1½	0.85	4.8854	4-7; 7-10; 10-12 and 13-15.
18	466	130,286	83.17	1½	0.6	4.947	

GERMAN PUDDLED STEEL. FALKENWORTH ROCHER & CO. NOT TEMPERED.

No.	Breaking strain.	Strength per square inch.	Feet in the lb.	Stretch.	Per cent. of length.	Length.	Drawn from.
8	2226	110,200	14.75	1½	0.6	5.0625	4-8. Drawn in Germany.
9	1778	106,900	17.87	1½	0.82	5.026	4-9 " " "
9	1820	108,700	17.75	1½	1.2	4.9948	4-9 " " "

CAST-STEEL, PIANO WIRE. (M. PÜHLMANN, NUREMBERG.)

No.	Breaking Strain.	Strength per sq. inch.	Feet in the lb.	Stretch	Per cent. of length.	Length.	Drawn from.
14	1624	302,500	55.4	1½	1.8	5.1944	drawn wet, no annealing below 10.
14½	1400	299,225	63.5	1½	2.6	4.96	
15	1008	263,117	70.8	1½	1.8	4.69	
15	1078	270,000	74.5	1½	1.6	4.656	
16	774	249,700	96.0	1½	1.6	4.5	
16½	812	283,320	103.8	1½	2.0	4.865	
16¾	784	275,525	104.8	1½	1.2	4.9	
16¾	763	261,576	102.0	1½	1.4	4.78	

## CAST-STEEL. (JOHNSON, NEPHEW.)

No.	Breaking Strain.	Strength per sq. inch.	Feet in the lb.	Stretch.	Per cent. of length.	Length.	Drawn from.
8	3220	158,823	14.67	$1\frac{3}{8}$	2.2	5.043	4-8
8	3262	160,000	14.5	$1\frac{1}{2}$	3	5.0143	4-8
8	3160	155,400	14.6	$1\frac{3}{8}$	2	5.026	4-8

## CAST-STEEL. (WEBSTER, HORSFALL.)

No.	Breaking Strain.	Strength per sq. inch.	Feet in the lb.	Stretch.	Per cent. of length.	Length.	Drawn from.
9	2856	167,601	17.6	$1\frac{1}{2}$	2	4.96	4-8, then tempered and finished in 1 hole.
9	2812	166,122	17.6	$1\frac{1}{2}$	1.8	4.96	
9	2842	168,506	17.6	$1\frac{1}{2}$	1.8	4.96	
10	1988	150,560	22.6	$\frac{7}{8}$	1.4	4.927	

The following results were computed from experiments by the late J. A. Roebling, the eminent engineer of the Niagara, Cincinnati and other suspension bridges, on the comparative strength of iron-wire rope and of hemp rope. The breaking weight being in tons of 2,000 lbs.

No.	Circumference of wire rope in inches.	Area of section in sq. inches.	Trade number.	Circumference of hemp rope in inches.	Area of section in sq. inches.	Tearing strain per square inch in tons.	
						Wire rope.	Hemp rope.
1	4.9	1.9	4	12	11.45	22.8	3.8
2	3.91	1.22	6	9.5	7.18	22.3	3.78
3	2.98	0.7	8	7	3.9	22.8	4.1
4	4.00	1.27	12	10	7.95	23.6	3.77
5	2.98	0.7	15	7.25	4.18	22.8	3.82

*Note.* Nos. 1, 2, 3, were made of what is known as fine wire; Nos. 4, 5, of coarse wire.

372. **Effects of Temperature on the Tensile Strength of Wrought Iron.** The experiments made under the direction of the Franklin Institute, already noticed, have developed some very curious facts of an anomalous character, with respect to the effect of an increase of temperature upon the

strength of wrought iron. It was found that at high degrees of heat the tensile strength was greater up to a certain point than was exhibited by the same iron at ordinary temperatures. The Sub-committee in their Report remark: "This circumstance was noted at 212°, 392°, and 572°, rising by steps of 180° each from 32°, at which last point some trials have been made in melting ice. At the highest of these points, however, it was perceived that some specimens of the metal exhibited but little, if any, superiority of strength over that which they had possessed when cold, while others allowed of being heated nearly to the boiling-point of mercury, before they manifested any decided indications of a weakening effect from increase of temperature."

"It hence became apparent that any law, taking for a basis the strength of iron in its ordinary condition, and at common temperatures, must be liable to great uncertainty, in regard to its application to different specimens of the metal. It was evident that the anomaly above referred to must be only apparent, and that the tenacity actually exhibited at 572°, as well as that which prevails while the iron is in the state in which it was left by forging or rolling, must be below its maximum tenacity."

From the experiments made upon several bars of the same iron, it appeared that their "maximum tenacity was 15.17 per cent. greater than their mean strength when tried cold."

Calculating the maximum tenacity in other experiments from this standard, the Sub-committee have drawn up the following table exhibiting the relations between diminutions from the maximum tenacity and the degrees of temperature by which they are caused, from which the curve representing the law of these relations can be constructed.

The Sub-committee remark on the construction of the above table: "As some of the experiments which furnished the standards of comparison for strength at ordinary temperatures were made at 80°, and as at this point small variations with respect to heat appear to affect but very slightly the tenacity of iron, it was conceived that for practical purposes, at least, the calculations might be commenced from that point."

"It will be found that with the exception of a slight anomaly between 520° and 570°, amounting to  $-.08$ , the numbers expressing the ratios between the elevations of temperature, and the diminutions of tenacity, constantly increase until we reach 932°, at which it is 2.97, and that from this point the ratio of diminution decreases to the limits of our range of trials, 1317°, where it is 2.14. It will also be observed, that

the diminution of tenacity at 932°, where the law changes from an increasing to a decreasing rate of diminution, is almost precisely one-third of the total, or *maximum* strength of the iron at ordinary temperatures."

TABLE.

No. of the comparison.	Observed temperatures.	Observed temperatures—80°.	Observed diminution of tenacity.	Power of the temperature which represents the diminution of tenacity at each point.
1	520°	440°	.0738	2.25
2	570	490	.0869	2.17
3	596	516	.0899	2.38
4	662	582	.1155	2.67
5	770	690	.1627	2.85
6	824	744	.2010	2.94
7	932	852	.3324	2.97
8	1030	950	.4478	2.92
9	1111	1031	.5514	2.63
10	1155	1075	.6000	2.60
11	1237	1157	.6622	2.41
12	1317	1237	.7001	2.14
				Mean 2.58

From the mean of all the rates in the above table the following rule is deduced: "*the thirteenth power of the temperature above 80° is proportionate to the fifth power of the diminution from the maximum tenacity.*"

Professor W. R. Johnson, a member of the Sub-committee, has since applied the results developed in the preceding experiments to practical purposes, in increasing the tenacity of wrought iron by subjecting it to tension under a high degree of temperature, before using it for purposes in which it will have to undergo considerable strains, as, for example, in chain cables, etc.

This subject was brought by Prof. Johnson before the Board of Navy Commissioners in 1841; subsequently, experiments were made by him under direction of the Navy Department the results of which, as exhibited in the following table, were published in the *Senate Public Documents* (1), 28th Congress, 2d Session, p. 641. Dec. 3, 1844.

Prof. Johnson in his letter remarks: "It will be observed that in these experiments the temperature has, with a view to economy of time, been limited to 400°, whereas the best

effects of the process have generally been obtained heretofore when the heat has been as high as 575°."

*Table of the Effects of Thermo-tension on the Tenacity and Elongation of Wrought Iron.*

KIND OF IRON.	Strength of cold.	Strength after treating with Thermo-tension.	Gain of length.	Gain of strength by the treatment.	Total gain of value.
Tredegar, No. 1, round iron	60	71.4	6.51	19.00	25.51
Do. do.	60	72.0	6.51	20.00	26.51
Tredegar, square bar iron	60	67.2	6.77	12.00	18.77
Tredegar, No. 3, round iron	58	68.4	5.263	17.93	23.19
Salisbury, round (Ames')	105.87	121.0	3.73	14.29	18.02
Mean,	—	—	5.75	16.64	22.40

From the experiments of Mr. Kirkaldy it appears that "wrought iron is injured by being brought to a white heat if not at the same time hammered or rolled."

*Resistance of Wrought Iron and Steel to a Shearing Strain.* From the experiments of Mr. Clark on plates joined by a single wrought-iron rivet, and those of Mr. Kirkaldy on steel rivets, it appears that the resistance to a shearing strain of the former was very nearly equal to its tensile strength; and for the latter that it was about three-fourths of its tensile strength.

**373. Resistance of Iron Wire to Impact.** The following table of experiments gives the results obtained by Mr. Hodgkinson, by suspending an iron ball at the end of a wire (diameter No. 17), and letting another iron ball impinge upon it from different altitudes. The suspended and impinging balls had holes drilled through them, through which the wire passed. A disk of lead was placed on the suspended ball to receive the blow, and lessen the recoil from elasticity.

The following observations are made by Mr. Hodgkinson: "To ascertain the strength and extensibility of this wire, it was broken in a very careful experiment with 252½ lbs., suspended at its lower end, and laid gradually on. And to obtain the increment of a portion of the wire (length 24 ft. 8 in.) when loaded by a certain weight, it had 139 lbs. hung at the bottom, and when 89 lbs. were taken off the load, the wire decreased in length .39 inch.



TABLE.

Length of wire.	Weight of striking ball.	Weight of suspended ball and lead.	Height fallen through by striking ball.	Wire broke with ball falling through.	Remarks.
ft. in.	lbs. oz.	lbs. oz.			
25 0	5 14	0 9	2, 2½, 3, 3½, 4	4½	No lead.
—	—	—	(repeated) 2½, 3, 3½, 4, 4½,	5	
24 0	6 0	10 1	(repeated with fresh wire,) 6,	6½	The wire usually broke near the point of impact, and it was adjusted to its length, if fresh wire were not used by a reserve at the top. Broke one inch from top.
—	—	44 0	1, 2, 3, 4, 5, 6, 6½, 7,	7	
—	—	80 8	6, 6½, 7, 7½, 8, 8½, 9,	7½	
—	—	89 0	8, 8½, 9, 9½, 10, 10½,	9½	
—	—	125 0	8, 8½, 9, 9½, 10,	11	
—	40 0	10 1	3, 4 inches,	10½	
—	—	80 8	2, 3, 4, 5, 6 inches,	5 inches	
—	—	80 0	4, 5 inches,	7 do.	
—	—	44 0	2 inches,	6 do.	
24 8	85 0	44 0		3 do.	

"Should it be suggested that the wire by being frequently impinged upon would perhaps be much weakened, the author would beg to refer to a paper of his on Chain Bridges, *Manchester Memoirs*, 2d series, vol. 5, where it is shown that an iron wire broken by pressure several times in succession is very little weakened, and will nearly bear the same weight as at first."

"The first of the preceding experiments on wires are the only ones from which the maximum can, with any approach to certainty, be inferred; and we see from them that the wire resisted the impulsion with the greatest effect when it was loaded at bottom with a weight, which, added to that of the striking body, was a little more than one-third of the weight that would break the wire by pressure."

"From these experiments generally, it appears that the wire was weak to bear a blow when lightly loaded."

"These last experiments and remarks, and some of the preceding ones" (on horizontal impact), "show clearly the benefit of giving considerable weight to elastic structures subject to impact and vibration."

374. **Resistance to Torsion of Wrought and Cast Iron.**  
—The following table exhibits the results of experiments made by Mr. Dunlop, at Glasgow, on round bars of wrought iron. The twisting weights were applied with an arm of lever 14 feet 2 inches.

Length of bars in inches.	Diameter of bars in inches.	Weight in lbs. producing rupture.
2½	2	250
2½	2½	384
3	2½	408
3	2½	700
4	3½	1170
5	3½	1240
5	3½	1663
5	4	1938
6	4½	2158

*Table of Experiments made by Mr. G. Rennie upon Cast and Wrought Iron. Weight applied at an arm of lever of 2 feet.*

MATERIAL.	Length of blocks in inches.	Size of sectional area.	Mean breaking weight in lbs.	
Iron cast horizontally.....	0	½	9	15
“ vertically.....	0	½	10	10
“ horizontally.....	½	½	7	8
“ “.....	½	½	8	1
“ “.....	1	½	8	8
“ vertically.....	½	½	10	1
“ “.....	½	½	8	9
“ “.....	1	½	8	5
“ “.....	6	½	9	12
“ horizontally.....	0	½	93	12
“ “.....	0	½	74	
“ “.....	10	½	53	
Wrought iron ( <i>English</i> ).....	0	½	10	2
“ ( <i>Swedish</i> ).....	0	½	9	8

VII.

STRENGTH OF STEEL.

375. FROM experiments made in Sweden by a government commission it appears that both the ductility and the strength of steel and iron are influenced by the amount of carbon they contain.

The experiments show that the hardest material has the greatest strength both before and after a permanent set has taken place from the force employed ; but its ductility is also the least. The Bessemer steel in these experiments gave the same results as the other processes for obtaining steel, the same pig iron being used in each case.

The limit for the amount of carbon for the Bessemer steel is from 1.2 to 1.5 per cent. With a larger amount both the strength and ductility was found to decrease. When the amount of carbon does not exceed 0.4 per cent. the ductility of Bessemer steel is about the same as puddled iron from the same pig iron, and as it is not only much stronger but more dense and homogeneous than the puddled material, it is decidedly superior for railway purposes.

From the experiments of the same commission that the strength both of iron and steel, subjected to strains between the extremes of temperature of boiling water and freezing mercury, was greater during low than at ordinary temperatures.

The cheaper methods which have been introduced into the manufacture of steel within but a few years past, have brought this material within the class of the ordinary materials for engineering purposes ; as railroad bars, bridges, etc. ; and has led to a very extensive series of experiments upon its resistance to the usual strains on building materials ; among the most noted of which are those of Mr. Fairbairn and of Mr. Kirkaldy.

The results of Mr. Fairbairn's experiments, *Report of the British Association, 1867*, give for the mean rupturing strain from extension 106,848 lbs. per square inch ; and for compression a mean rupturing strain of 225,568 lbs. per square inch.

From the same series of experiments upon bars deflected under moderate transverse strains the coefficient or modulus of elasticity deduced was 31,000,000 lbs. per square inch.

From the experiments already referred to by Mr. Kirkaldy, the following general conclusions were arrived at:—

1. The breaking strain of steel, when taken alone, gives no clue to the real qualities of various kinds of that metal (74).
2. The contraction of area at fracture of specimens of steel must be ascertained as well as in those of iron (74).
3. The breaking strain, *jointly* with the contraction of area, affords the means of comparing the peculiarity in various lots of specimens (74, 75).
4. Some descriptions of steel are found to be very hard,

and, consequently, suitable for some purposes, whilst others are extremely soft, and equally suitable for other uses (74, 75, 78).

5. The breaking strain and contraction of area of *puddled* steel plates, as in iron plates, are greater in the direction in which they are rolled, whereas in *cast* steel they are less (74, 75).

6. Steel invariably presents, when fractured slowly, a silky fibrous appearance.

7. When fractured suddenly the appearance is invariably granular, in which case the fracture is always at right angles to the length; when the fracture is fibrous, the angle diverges always more or less from 90°.

8. Steel which previously broke with a silky fibrous appearance is changed into granular by being hardened (141).

9. Steel is reduced in strength by being hardened in water, while the strength is vastly increased by being hardened in oil (161, 162, 164).

10. The higher steel is heated (without, of course, running the risk of being burned) the greater is the increase of strength by being plunged into oil (161, 162).

11. In a highly converted or hard steel the increase in strength and in hardness is greater than in a less converted or soft steel (161, 162).

12. Heated steel, by being plunged into oil instead of water, is not only considerably *hardened*, but *toughened* by the treatment (162).

13. Steel plates hardened in oil and joined together with rivets are fully equal in strength to an unjointed soft plate, or the loss of strength by riveting is more than counterbalanced by the increase in strength by hardening in oil (163).

14. Steel rivets fully larger in diameter than those used in riveting iron plates of the same thickness being found to be greatly too small for riveting steel plates, the probability is suggested that the proper proportion for iron rivets is not, as generally assumed, a diameter equal to the thickness of the two plates to be joined (163).

15. The shearing strain of steel rivets is found to be about a fourth less than the tensile strain (163).

16. The welding of steel bars, owing to their being so easily burned by slightly overheating, is a difficult and uncertain operation (181, 15).

17. The most highly converted steel does not, as some may suppose, possess the greatest density (196).

18. In cast steel the density is much greater than in puddled steel, which is even less than in some of the superior descriptions of wrought iron (196).

From experiments made by Major Wade, late of the U. S. Ordnance Corps, the following results were obtained for the crushing weights of cast iron on the square inch:—

Not hardened.....	198,944 lbs.
Hardened; low temper.....	354,544 "
Hardened; mean temper.....	391,985 "
Hardened; high temper.....	372,598 "

From contracts made by direction of Mr. James B. Eads, chief engineer of the Illinois and St. Louis bridge, at St. Louis, Missouri, the staves of the arches, the pins and plates are to be of the *crucible cast steel* of commerce. Those parts subjected to compression are to withstand 60,000 pounds on the square inch, and those subjected to a tensile strain 40,000 pounds on the square inch without permanent set, and all must stand a tensile strain of 100,000 pounds on the square inch without fracture.

The *modulus of elasticity* of the steel not to be less than 26,000,000 pounds, nor more than 30,000,000.

---

## VIII.

### STRENGTH OF COPPER.

THE various uses to which copper is applied in constructions, render a knowledge of its resistance under various circumstances a matter of great interest to the engineer.

**376. Resistance to Tensile Strain.** The resistance of *cast* copper on the square inch, from the experiments of Mr. G. Rennie, is 8.51 tons, that of *wrought* copper reduced per hammer at 15.08 tons. Copper wire is stated to bear 27.30 tons on the square inch. From the experiments made under the direction of the *Franklin Institute*, already cited, the mean strength of rolled sheet copper is stated at 14.35 tons per square inch.

*Resistance to Compressive Strain.* Mr. Rennie's experiments on cubes of one-fourth of an inch on the edge, give for the crushing weight of a cube of cast copper 7,318 lbs., and of wrought copper 6,440 lbs.

**377. Effects of Temperature on Tensile Strength.**—The experiments already cited of the Franklin Institute, show that the difference in strength at the lower temperatures, as between 60° and 90°, is scarcely greater than what arises from irregularities in the structure of the metal at ordinary temperatures. At 550° Fahr. copper loses *one-fourth* of its tenacity at ordinary temperatures, at 817° precisely *one-half*, and at 1000° *two-thirds*.

Representing the results of experiments by a curve of which the ordinates represent the temperatures above 32°, and the abscissas the diminutions of tenacity arising from increase of temperature, the relations between the two will be thus expressed: *the squares of the diminutions are as the cubes of the temperatures.*

---

## IX.

### STRENGTH OF OTHER METALS.

**378. MR. RENNIE** states the tenacity of *cast tin* at 2.11 tons per square inch; and the resistance to compression of a small cube of  $\frac{1}{4}$  of an inch on an edge at 966 lbs.

In the same experiments, the tenacity of *cast lead* is stated at 0.81 tons per square inch; and the resistance of a small cube of same size as in preceding paragraph at 483 lbs.

In the same experiments, the tenacity of hard gun-metal is stated at 16.23 tons; that of fine yellow brass at 8.01 tons. The resistance to compression of a cube of brass the same as before mentioned, is stated at 10,304 lbs.

---

## X.

### LINEAR CONTRACTION AND EXPANSION OF METALS AND OTHER MATERIALS FROM TEMPERATURE.

**379. Coefficients of Linear Expansion.**—The change of length which takes place in a bar of any material estimated in fractional parts of its length at 0° Centigrade, for a

change in temperature of 1° Centigrade, is termed the *coefficient of linear expansion*, for the material in question.

The increase in length for other changes of temperature than 1° is given by the following formula:—

$$l = KNL,$$

in which L is the length at 0° C.; N, the number of degrees above 0°; K, the coefficient of linear expansion; and *l* the increase of length due to N degrees above 0° C.

*Table of Coefficients of Linear Expansion for 1° C.*

DESCRIPTION OF MATERIAL.	Authority.	Coefficients of linear expansion for 1° C.
<b>METALS.</b>		
Antimony.....	Smeaton	000010833
Bismuth.....	"	000018916
Brass (supposed to be Hamburg plate brass)..	Ramsden	000018554
" (English plate, in form of a rod).....	"	000018928
" (English plate, in form of trough).....	"	000018949
" (cast).....	Smeaton	000018750
" (wire).....	.....	000019833
Copper.....	{ Laplace & }	000017122
" .....	{ Lavoisier. }	"
" .....	"	000017224
Gold (de départ).....	"	000014660
" (standard of Paris, not annealed).....	"	000015515
" (" " annealed).....	"	000015136
Iron (cast).....	Ramsden	000011094
" (from a bar cast 2 inches square).....	Adie	000011467
" (from a bar cast ½ an inch square).....	"	000011023
" (soft forged).....	{ Laplace & }	000012304
" .....	{ Lavoisier }	"
" (round wire).....	"	000012350
" (wire).....	Troughton	000014401
Lead.....	{ Laplace & }	000028484
" .....	{ Lavoisier }	"
" .....	Smeaton	000028666
Palladium.....	Wollaston	000010000
Platina.....	Dulong & Petit	000008842
" .....	Troughton	000009918
Silver (of cupel).....	{ Laplace & }	000011097
" .....	{ Lavoisier }	"
" (Paris standard).....	"	000019086
" .....	Troughton	000020628
Solder (white; lead 2, tin 1).....	Smeaton	000025058
" (spelter; copper 2, zinc 1).....	"	000025583
Speculum metal.....	"	000019333

DESCRIPTION OF MATERIALS.	Authority.	Coefficients of linear expansion for 1° C.
Steel (untempered).....	{ Laplace & Lavoisier }	000010788
“ (tempered yellow, annealed at 65° C.)..	“	000012395
“ (blistered).....	Smeaton	000011500
“ (rod).....	Ramsden	000011447
Tin (from Malacca).....	{ Laplace & Lavoisier }	000010376
“ (from Falmouth).....	“	000021729
Zinc.....	Smeaton	000029416
TIMBER.		
Baywood (in the direction of the grain, dry).....	Joule	{ 00000461 to 00000566
Deal (in the direction of the grain, dry).....	....	{ 00000428 to 00000438
STONE, BRICK, GLASS, CEMENT.		
Arborath pavement.....	Adie	000008985
Brick (best stock).....	“	000005502
“ (fire).....	“	000004928
Caithness pavement.....	“	000008947
Cement (Roman).....	“	000014349
Glass (English flint).....	{ Laplace & Lavoisier }	000008117
“ (French with lead).....	“	000008720
Granite (Aberdeen gray).....	Adie	000007894
“ (Peterhead red, dry).....	“	000008968
“ ( “ “ moist).....	“	000009583
Greenstone (from Katho).....	“	000008089
Marble (Carrara moist).....	“	000011928
“ ( “ dry).....	“	000006539
“ (black Galway).....	“	000004452
“ (black, softer specimen, containing more fossils).....	“	000004793
“ (Sicilian, white moist).....	“	000014147
“ ( “ “ dry).....	“	000011041
Sandstone (from Craigeith quarry).....	“	000011743
Slate (from Penrhyn quarry, Wales).....	“	000010376

It has been found from experiment that the absorption of water in any manner decreases the coefficient of linear expansion in wood; and that, in some cases, in stone it increases this coefficient, whilst in others a permanent increase of length took place from an increase of temperature.

An increase in temperature of 15° C. in cast iron, and 8°



C. in wrought iron will produce a strain of one ton of 2240 lbs. on the square inch, when the two ends of the bar abut against a fixed object.

---

## XI.

### ADHESION OF IRON SPIKES TO TIMBER.

380. THE following tables and results are taken from an article by Professor Walter R. Johnson, published in the *Journal of the Franklin Institute*, Vol. 19, 1837, giving the details of experiments made by him on spikes of various forms driven into different kinds of timber.

The first series of experiments was made with Burden's plain square spike, the flanché, grooved, and swell spike, and the grooved and swelled spike. The timber was seasoned Jersey yellow pine, and seasoned white oak.

From these experiments it results, that the grooved and swelled form is about 5 per cent. less advantageous than the plain, in yellow pine, and about  $18\frac{1}{2}$  per cent. superior to the plain in oak. The advantage of seasoned oak over the seasoned pine, for retaining plain spikes, is as 1 to 1.9, and for grooved spikes as 1 to 2.37.

The second series of experiments, in which the timber was soaked in water after the spikes were driven, gave the following results:—

For swelled and grooved spikes, the order of retentiveness was: 1 locust; 2 white oak; 3 hemlock; 4 unseasoned chestnut; 5 yellow pine.

For grooved spike without swell, the like order is: 1 unseasoned chestnut; 2 yellow pine; 3 hemlock.

The swelled and grooved spike was, in all cases, found to be inferior to the same spike with the swell filed off.

The third series of experiments gave the following results:

Thoroughly seasoned oak is *twice*, and thoroughly seasoned locust  $2\frac{3}{4}$  times as retentive as unseasoned chestnut.

The forces required to extract spikes are more nearly proportional to the breadths than to either the thickness or the weights of the spikes. And, in some cases, a diminution of thickness with the same breadth of spike afforded a gain in retentiveness.

"In the softer and more spongy kinds of wood the fibres, instead of being forced back longitudinally and condensed upon themselves, are, by driving a thick, and especially a rather obtusely-pointed spike, folded in masses backward and downward so as to leave, in certain parts, the faces of the grain of the timber in contact with the surface of the metal."

"Hence it appears to be necessary, in order to obtain the greatest effect, that the fibres of the wood should press the faces as nearly as possible in their longitudinal direction, and with equal intensities throughout the whole length of the spike."

The following is the order of superiority of the spikes from that of the ratio of their weights and extracting forces respectively:—

1. Narrow flat.....	7.049	ratio of weight to extracting force.
2. Wide flat.....	5.712	" " "
3. Grooved but not swelled.	5.662	" " "
4. Grooved and not notched.	5.300	" " "
5. Grooved and swelled....	4.624	" " "
6. Burden's patent.....	4.509	" " "
7. Square hammered.....	4.129	" " "
8. Plain cylindrical.....	3.200	" " "

"All the experiments prove, that when a spike is once started the force required for its final extraction is much less than that which produced the first movement."

"When a bar of iron is spiked upon wood, if the spike be driven until the bar compresses the wood to a great degree, the recoil of the latter may become so great as to start back the spike for a short distance after the last blow has been given."

342. From the fourth series of experiments it appears, that the spike tapering gradually towards the cutting edge gives better results than those with more obtuse ends.

That beyond a certain limit the ratio of the weight of the spike to the extracting force begins to diminish; "showing that it would be more economical to increase the number rather than the length of the spikes for producing a given effect."

"That the absolute retaining power of unseasoned chestnut on square or flat spikes of from two to four inches in length is a little more than 800 lbs. for every square inch of their two faces which condense longitudinally the fibres of the timber."

## CHAPTER III.

### MASONRY.

I CLASSIFICATION OF. II. CUT STONE MASONRY. III. RUBBLE-STONE MASONRY. IV. BRICK MASONRY. V. FOUNDATIONS OF STRUCTURES ON LAND. VI. FOUNDATIONS OF STRUCTURES IN WATER. VII. CONSTRUCTION OF MASONRY.

#### SUMMARY.

##### I.

###### CLASSIFICATION OF MASONRY.

Masonry defined and classified (Art. 381).

##### II.

###### CUT STONE MASONRY.

Definitions (Art. 383). Requisites of Strength (Arts. 384-390). Bonds (Arts. 391-392). Cutting (Art. 393).

##### III.

###### RUBBLE-STONE MASONRY.

Quality (Art. 394). Construction (Arts. 395-397).

##### IV.

###### BRICK MASONRY.

Construction (Arts. 398-402). Concrete Walls (Arts. 403-410).

## V.

## FOUNDATIONS OF STRUCTURES ON LAND.

Foundation defined (Art. 417). Importance (Art. 418). Classification of Soils (Art. 420). Foundations on Rock (Art. 421). In Stony Ground (Arts. 422-423). On Sand (Art. 424). Precautions against water (Art. 425). In Compressible Soils (Arts. 426-429). In Marshy Soils (Art. 430). On Piles (Art. 431). Pile Engines (Art. 432). Pile driving (Arts. 432-434). Load placed on piles (Arts. 435-436). Piles prepared for foundation (Arts. 437-439). On Sand (Art. 441). Precautions against Lateral Yielding (Art. 443).

## VI.

## FOUNDATIONS OF STRUCTURES IN WATER.

Difficulties (Art. 444). Use of Dams (Arts. 445-449). Use of Caisson (Art. 450). Artificial Island (Art. 452). Protection against running water (Arts. 454-455). Pneumatic processes (Art. 456). Pneumatic piles (Arts. 457-458). Pneumatic Caissons (Art. 459).

## VII.

## CONSTRUCTION OF MASONRY.

Foundation Courses (Arts. 461-463). Inverted arches (Art. 464). Component parts of structures of Masonry (Art. 467). Walls of Enclosures (Art. 468). Vertical Supports (Art. 469). Areas (Art. 470). Retaining Walls (Arts. 471-475). Form of Section of Retaining Walls (Arts. 476-478). Measures for increasing the Strength of Retaining Walls (Arts. 479-488). Counterforts (Arts. 480-483). Relieving Arches (Art. 484). Lintel (Art. 490). Plate-bande (Art. 491). Arches (Arts. 492-494). Classification of Arches (Art. 495). Cylindrical Arches (Arts. 496-502). Oblique Arch (Arts. 502-503). Groined and Cloistered Arch (Arts. 504-505). Conical Arch (Art. 506). Conoidal Arch (Arts. 507-508). Annular Arch (Art. 509). Dome (Art. 510). Arrangement of voussoirs (Arts. 511-513). Construction of Arches (Arts. 514-523). Rupture of Arches (Arts. 524-527). Precautions to be observed in constructing Arches (Arts. 528-533). Precautions against settling (Art. 534). Pointing (Arts. 535-537). Repairs of Masonry (Arts. 538-540). Effects of Temperature on Masonry (Art. 541).

## I

## CLASSIFICATION.

381. MASONRY is the art of raising structures, in stone, brick, and mortar.

Masonry is classified either from the nature of the material, as *stone masonry*, *brick masonry*, and *mixed*, or that which is composed of stone and brick; or from the manner in which the material is prepared, as *cut stone* or *ashlar masonry*, *rubble-stone* or *rough masonry*, and *hammered stone masonry*; or, finally, from the form of the material, as *regular masonry*, and *irregular masonry*.

---

## II.

## CUT STONE.

382. MASONRY of cut stone, when carefully made, is stronger and more solid than that of any other class; but, owing to the labor required in *dressing* or preparing the stone, it is also the most expensive. It is therefore mostly restricted to those works where a certain architectural effect is to be produced by the regularity of the masses, or where great strength is indispensable.

383. **Definitions.** Before explaining the means to be used to obtain the greatest strength in cut stone, it will be necessary to give a few definitions to render the subject clearer.

In a wall of masonry the term *face* is usually applied to the front of the wall, and the term *back* to the inside; the stone which forms the front, is termed the *facing*; that of the back, the *backing*; and the interior, the *filling*. If the front, or back of the wall, has a uniform slope from the top to the bottom, this slope is termed the *batter*, or *bâtir*.

The term *course* is applied to each horizontal layer of stone in the wall: if the stones of each layer are of equal thickness throughout it is termed *regular coursing*; if the thicknesses are unequal the term *random*, or *irregular coursing*, is applied. The divisions between the stones, in the courses, are

termed the *joints*; the upper surface of the stones of each course is also sometimes termed the *bed*, or *build*.

The arrangement of the different stones of each course, or of contiguous courses, is termed the *bond*.

**384. Requisites of Strength.** The strength of a mass of cut stone masonry will depend on the size of the blocks in each course, on the accuracy of the dressing, and on the bond used.

The size of the blocks varies with the kind of stone and the nature of the quarry. From some quarries the stone may be obtained of any required dimensions; others, owing to some peculiarity in the formation of the stone, furnish only blocks of small size. Again, the strength of some stones is so great as to admit of their being used in blocks of any size, without danger to the stability of the structure, arising from their breaking; others can be used only with safety when the length, breadth, and thickness of the block bear certain relations to each other. No fixed rule can be laid down on this point; that usually followed by builders is to make, with ordinary stone, the breadth at least equal to the thickness, and seldom greater than twice this dimension, and to limit the length to within three times the thickness. When the breadth or the length is considerable, in comparison with the thickness, there is danger that the block may break, if any unequal settling, or unequal pressure should take place. As to the absolute dimensions, the thickness is generally not less than one foot, nor greater than two; stones of this thickness, with the relative dimensions just laid down, will weigh from 1000 to 8000 pounds, allowing, on an average, 160 pounds to the cubic foot. With these dimensions, therefore, the weight of each block will require a very considerable power, both of machinery and men, to set it on its bed.

**385.** For the coping and top courses of a wall the same objections do not apply as to excess in length: but this excess may, on the contrary, prove favorable; because the number of top joints being thus diminished, the mass beneath the coping will be better protected, being exposed only at the joints, which cannot be made water-tight, owing to the mortar being crushed by the expansion of the blocks in warm weather, and, when they contract, being washed out by the rain.

**386.** The closeness with which the blocks fit is dependent solely on the accuracy with which the surfaces in contact are wrought or *dressed*; if this part of the work is done in a slovenly manner, the mass will not only present open joints from any inequality in the settling; but, from the courses not

fitting accurately on their beds, the blocks will be liable to crack from the unequal pressure on the different points of the block.

387. The surfaces of one set of joints should, as a prime condition, be perpendicular to the direction of the pressure: by this arrangement there will be no tendency in any of the blocks to slip. In a vertical wall, for example, the pressure being downward, the surfaces of one set of joints, which are the beds, must be horizontal. The surfaces of the other set must be perpendicular to these, and, at the same time, perpendicular to the face, or to the back of the wall, according to the position of the stones in the mass; two essential points will thus be attained,—the angles of the blocks, at the top and bottom of the course, and at the face or back, will be right angles, and the block will therefore be as strong as the nature of the stone will admit. The principles here applied to a vertical wall, are applicable in all cases whatever may be the direction of the pressure and the form of the exterior surfaces, whether plane or curved.

388. A modification of this principle, however, may in some cases be requisite, arising from the strength of the stone. It is laid down as a rule, drawn from the experience of builders, that no stone-work with angles less than  $60^\circ$  will offer sufficient strength and durability to resist accidents, and the effects of the weather. If, therefore, the batter of a wall should be greater than  $60^\circ$ , which is about 7 perpendicular to 4 base, the horizontal joints (Fig. 17) must not be carried out in the



Fig. 17—Represents the arrangement of stone with abutting, or elbow joints for very inclined surfaces.

A, face of the block.

c, elbow joint.

B, buttress block, termed a *netcell* stone.

same plane to the face or back, but be broken off at right angles to it, so as to form a small abutting joint of about 4 inches in thickness. As the batter of walls is seldom so great as this, except in some cases of sustaining walls for the side slopes of earthen embankments, this modification in the joints will not often occur; for, in a greater batter, it will generally be more economical, and the construction will be stronger, to place the stones of the exterior in offsets, the exterior stone of one course being placed within the exterior one of the course below it, so as to give the required general direction of the

batter. The arrangement with offsets has the further advantage in its favor of not allowing the rain water to lodge in the joint, if the offset be slightly bevelled off.

389. Workmen, unless narrowly watched, seldom take the pains necessary to dress the beds and joints accurately; on the contrary, to obtain what are termed *close joints*, they dress the joints with accuracy a few inches only from the outward surface, and then chip away the stone towards the back, or *tail* (Fig. 18), so that, when the block is set, it will be in con-



Fig. 18.—Represents a section of a wall in which the face is of cut stone, with the tails of the blocks thinned off, and the backing of rubble.  
A, section of face block.  
B, rubble backing.

tact with the adjacent stones only throughout this very small extent of bearing surface. This practice is objectionable under every point of view; for, in the first place, it gives an extent of bearing surface, which, being generally inadequate to resist the pressure thrown on it, causes the block to splinter off at the joint; and in the second place, to give the block its proper set, it has to be propped beneath by small bits of stone, or wooden wedges, an operation termed *pinning-up*, or *underpinning*, and these props, causing the pressure on the block to be thrown on a few points of the lower surface, instead of being equally diffused over it, expose the stone to crack.

390. When the facing is of cut stone, and the backing of rubble, the method of thinning off the block may be allowed for the purpose of forming a better bond between the rubble and ashlar; but, even in this case, the block should be dressed true on each joint, to at least one foot back from the face. If there exists any cause which would give a tendency to an outward thrust from the back, then instead of thinning off all the blocks towards the tail it will be preferable to leave the tails of some thicker than the parts which are dressed.

391. Various methods are used by builders for the bond of cut stone. The system termed *headers* and *stretchers*, in which the vertical joints of the blocks of each course alter-



nate with the vertical joints of the courses above and below it, or, as it is termed, *break joints* with them, is the most simple, and offers, in most cases, all requisite solidity. In this



Fig. 19 is a vertical section of the sea walls used for protecting the bluffs of the islands in Boston Harbor exposed to the action of the waves.

- A, Stone facing of heavy blocks well fitted and clamped.
- B, Concrete bed and backing.
- C, Top wall well bonded.
- D, Natural soil back of concrete.

system (Fig. 20), the blocks of each course are laid alternately with their greatest and least dimensions to the face of the wall; those which present the longest dimension along the face are termed stretchers; the others, headers. If the

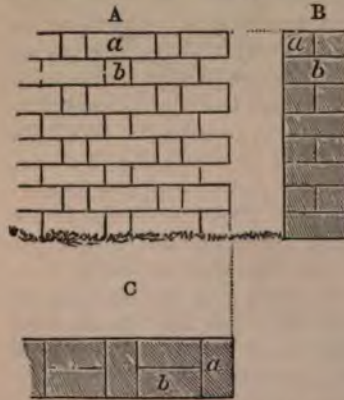

Fig 20—Represents an elevation A, end view B, and plan C, of a wall arranged as headers and stretchers.  
a, stretchers.  
b, headers.

header reaches from the face to the back of the wall, it is termed a *through*; if it only reaches part of the distance it is termed a *binder*. The vertical joints of one course are either just over the middle of the blocks of the next course below, or else, at least four inches on one side or the other of the vertical joints of that course; and the headers of one course rest as nearly as practicable on the middle of the

stretchers of the course beneath. If the backing is of rubble, and the facing of cut stone, a system of throughs or binders, similar to what has just been explained, must be used.

By the arrangement here described, the facing and backing of each course are well connected; and, if any unequal settling takes place, the vertical joints cannot open, as would be the case were they in a continued line from the top to the bottom of the mass; as each block of one course confines the ends of the two blocks on which it rests in the course beneath.

392. In masses of cut stone exposed to violent shocks, as those of which light-houses, and sea-walls in very exposed positions are formed, the blocks of each course require to be not only very firmly united with each other, but also with the courses above and below them. To effect this, various means have been used. The beds of one course are sometimes arranged with projections (Fig. 21) which fit into corresponding indentations of the next course. Iron cramps in the form of the letter S, or in any other shape that will answer the

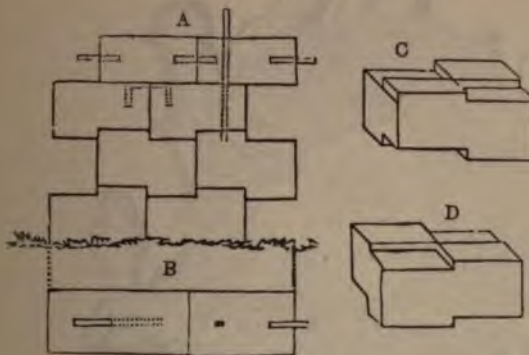

Fig. 21—Represents an elevation, A, plan, B, and perspective views, C and D, of two of the blocks of a wall in which the blocks are fitted with indentations, and connected with bolts and cramps of metal.

purpose of giving them a firm hold on the blocks, are let into the top of two blocks of the same course at a vertical joint, and are firmly set with melted lead, or with bolts, so as to confine the two blocks together. Holes are, in some cases, drilled through several courses, and the blocks of these courses are connected by strong iron bolts fitted to the holes.

The most noted examples of these methods of strengthening the bond of cut stone, are to be found in the works of the Romans which have been preserved to our time, and in two celebrated modern structures, the Eddy-stone and Bell-rock light-houses in Great Britain (Fig. 22).



Fig. 23—Represents the manner of arranging stones of the same course by dove-tail joints and joggling, taken from a horizontal section of the masonry of the Bell-rock lighthouse.

Figs. 23, 24, 25, 26.—Plans and sections showing the masonry bond and metal fastenings of some of the courses in the Minot's ledge lighthouse.



Fig. 24.—Rock surface prepared for receiving foundation.

393. The manner of dressing stone belongs to the stone-cutter's art, but the engineer should not be inattentive either to the accuracy with which the dressing is performed, or the means employed to effect it. The tools chiefly used by the workman are the chisel, axe, and hammer for *knotting*. The usual manner of dressing a surface is to cut draughts around and across the stone with the chisel, and then to use the chisel,

the axe with a serrated edge, or the knotting hammer, to work down the intermediate portions into the same surface with the draughts. In performing this last operation, the chisel and

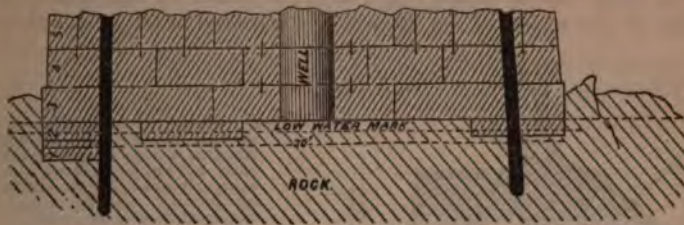

Fig. 24.—Vertical section showing foundation courses and their metal fastenings.

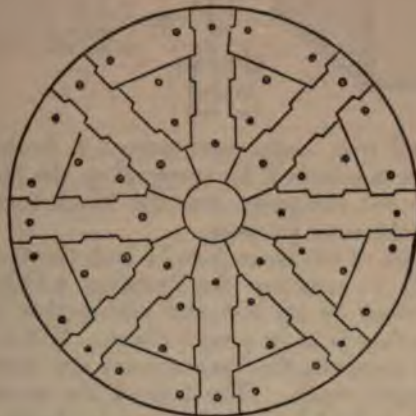

Fig. 25.—Plan showing bond of stone and fastenings above the solid foundation courses.

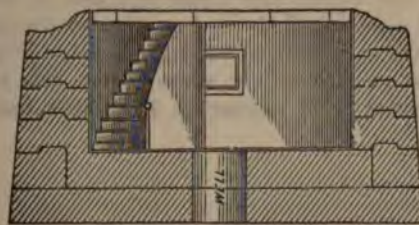

Fig. 26.—Vertical section and interior elevation above foundation courses.

AXE should alone be used for soft stones, as the grooves on the surface of the hammer are liable to become choked by a soft

material, and the stone may in consequence be materially injured by the repeated blows of the workman. In hard stones this need not be apprehended.

In large blocks which require to be raised by machinery, a hole, of the shape of an inverted truncated wedge, is cut to

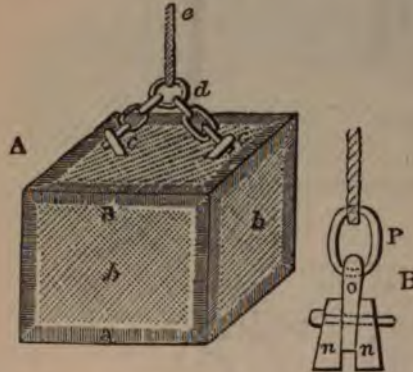

Fig. 27.—Represents a perspective view, A, of a block of stone with draughts around the edges of its faces, and the intermediate space axed, or knotted, and its tackling for hoisting; also the common iron lewis, B, with its tackling.  
*a*, draughts around edge of block.  
*b*, knotted part between draughts.  
*c*, iron bolts with eyes let into oblique holes cut in the block.  
*d* and *e*, chain and rope tackling.  
*n, n*, side pieces of the lewis.  
*o*, centre piece of lewis with eye fastened to *n n* by a bolt.  
*p*, iron ring for attaching tackling.

receive a small iron instrument termed a *lewis* (Fig. 27), to which the rope is attached for suspending the block; or else, two holes are cut obliquely into the block to receive bolts with eyes for the same purpose.

When a block of cut stone is to be laid, the first point to be attended to is to examine the dressing, which is done by placing the block on its bed, and seeing that the joints fit close, and the face is in its proper plane. If it be found that the fit is not accurate, the inaccuracies are marked and the requisite changes made. The bed of the course on which the block is to be laid is then thoroughly cleansed from dust, &c., and well moistened, a bed of thin mortar is laid evenly over it, and the block, the lower surface of which is first cleansed and moistened, is laid on the mortar-bed, and well settled by striking it with a wooden mallet. When the block is laid against another of the same course, the joint between them is prepared with mortar in the same manner as the bed.

## III.

## RUBBLE-STONE MASONRY.

394. With good mortar, rubble work, when carefully executed, possesses all the strength and durability required in structures of an ordinary character; and it is much less expensive than cut stone.

395. The stone used for this work should be prepared simply by knocking off all the sharp, weak angles of the block; it is then cleansed from dust, &c., and moistened, before placing it on its bed. This bed is prepared by spreading over the top of the lower course an ample quantity of good ordinary-tempered mortar, into which the stone is firmly embedded. The interstices between the larger masses of stone are filled in by thrusting small fragments, or chippings of stone, into the mortar. Finally, the whole course may be carefully grouted before another is commenced, in order to fill up any voids left between the full mortar and stone.

396. To connect the parts well together, and to strengthen the weak points, throughs or binders should be used in all the courses; and the angles should be constructed of cut or hammered stone. In heavy walls of rubble masonry, the precaution, moreover, should be observed, to lay the stones on their *quarry-bed*; that is, to give them the same position, in the mass of masonry, that they had in the quarry; as stone is found to offer more resistance to pressure in a direction perpendicular to the quarry-bed than in any other. The directions of the lamina in stratified stones show the position of the quarry-bed.

397. Hammered stone, or dressed rubble, is stone roughly fashioned into regular masses with the hammer. The same precautions must be taken in laying this kind of masonry as in the two preceding.

## IV.

## BRICK MASONRY.

398. With good brick and mortar, this masonry offers great strength and durability, arising from the strong adhesion between the mortar and brick.

399. The bond used in brick-work is very various, depending on the character of the structure. The most usual kinds are known as the *English* and *Flemish*. The first consists in arranging the courses alternately, entirely as headers or stretchers, the bricks through the course breaking joints. In the second the bricks are laid as headers and stretchers in each course. The first is stated to give a stronger bond than the last; the bricks of which, owing to the difficulty of preventing continuous joints, either in the same or different courses, are liable to separate, causing the face or the back to bulge outward. The Flemish bond presents the finer architectural appearance, and is therefore preferred for the fronts of edifices.

400. Timber and iron have both been used to strengthen the bond of brick masonry. Among the most remarkable examples of their uses are the well, faced in brick, forming an entrance to the Thames Tunnel, the celebrated work of Mr. Brunel, and his experimental arch of brick, a description of which is given in the *Civil Engineer and Architect's Journal*, No. 6, vol. I. In both these structures Mr. Brunel used pantile laths and hoop iron, in the interior of the horizontal courses, to connect two contiguous courses throughout their length. The efficacy of this method has been further fully tested by Mr. Brunel, in experiments made on the resistance to a transversal strain of a brick beam bonded with hoop iron, accounts of which, and of experiments of a like kind, are given by Colonel Pasley in his work on *Limes, Calcareous Cements, &c.*

401. The mortar-bed of brick may be either of ordinary or thin-tempered mortar; the last, however, is the best, as it makes closer joints, and, containing more water, does not dry so rapidly as the other. As brick has great avidity for water, it would always be well not only to moisten it before laying it, but to allow it to soak in water several hours before it is used. By taking this precaution, the mortar between the joints will set more firmly than when it imparts its water to the dry brick, which it frequently does so rapidly as to render the mortar pulverulent when it has dried.

402. On this point the late General Totten, Chief of Engineers, in his instructions for building brick masonry, observes: "The want of cohesion" between the brick and mortar, in the case of some gun practice against brick embrasures, "was due to the interposition of dust, sometimes quite free, but more generally composing a layer slightly cohering to the body of the bricks. The process of laying must be to cause

every brick to be thoroughly soaked in water, and to be laid the moment it ceases to drip."

**403. Concrete Walls.** The use of hydraulic concrete for the construction of both solid and hollow walls for houses has very much increased within a few years; and it is claimed that they are drier, stronger, and cheaper than walls of brick of equal thickness.

In some of the cheaper structures of this class put up in Paris, the concrete was composed of one part in volume of Portland cement, and from five to eight parts of clean screened gravel from the size of pearl barley to that of peas; and in some cases instead of gravel what is known as brick ballast, or the small fragments of ordinary brick from which all the fine dust is screened out, is used, taking eight parts of this to one of Portland cement.

**404.** For building walls of concrete where a scaffold is not necessary it is only requisite to have a boxing formed of scantling and boards of the width of the wall within, between the two sides of which the concrete is thrown in and rammed.

**405.** For solid walls requiring a scaffolding, what is termed all's bracket scaffolding is used. The concrete is laid with-



Fig. 28 represents a vertical section of the boxing for laying concrete walls.

- A, Boarding confined by clamp screws.
- B, Platform supported by brackets and clamp screws.
- C, Cylinder for forming flues in the wall.

in the boxing, which consist of boards, A, held together by clamp screws, *b*, which pass through hollow iron cones placed between the sides of the boxing, which, within, is of the same height and width as the layer of concrete to be laid at a time. When the layer is finished the boxing is taken apart, and the holes left by the cones when removed are used for securing the brackets of the scaffolding, which consists of triangular frames, B, each formed of a vertical pin, a horizontal beam to support the flooring, and an inclined strut to support the outer end of the horizontal beam. The flooring, of sufficient width for the workmen, projects beyond the wall on each side, and the two parts without and within are held together



by clamp screws which pass through the holes. When cylindrical flues are to be left within the body of the wall, a cylinder C, with a handle to it, of the requisite diameter, and the length of the thickness of the layer, is placed in position, and the concrete rammed well around it. When a new layer is to be laid the cylinder is drawn up from the one finished.

406. For constructing either solid or hollow walls, an apparatus devised by Mr. Clarke of New Haven, Conn., termed Clarke's adjustable frame for concrete building, is used. This

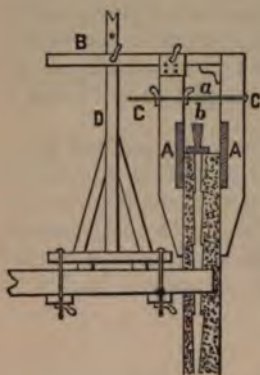

Fig. 29. Vertical section of boxing for hollow walls of concrete.

- A, Boxing confining concrete.
- B, Horizontal arm supporting the pieces C.
- D, Vertical support of B.
- a, Clamp screws confining C, C.
- b, Board used for forming the void in the wall.

consists of a boxing of boards, A, for laying the concrete which is held together by frames, each composed of a horizontal piece, B, to which are affixed two vertical clamping pieces, C, the interior piece being movable and capable of being adjusted by screws, the two pieces being held together by a clamp screw, *a*; the frames and boxing being attached to vertical supports, D, within the building, in which holes are arranged at suitable distances to admit of the frame being placed at the proper height. For hollow walls a wedge-shaped board, *b*, two inches and a half thick at its broad end, and two inches on the other, is used. This board has rectangular notches of the width of a brick, and placed at twenty inches apart, cut into the narrow edge. This forms the core for the hollow portion of the wall. The work is started or continued by placing the bricks in place lengthwise across the hollow so as to tie the exterior and interior portions of the wall together. The core is then placed with its notches fitting on the bricks, and secured in a vertical position, the concrete is filled in on each side between the sides of the boxing. When the layer is finished the core is drawn up.

For further applications of *Coignet Béton*, see *Prof. Barnard's Report on the Paris Exposition of 1867*, and *Gen. Gilmore's Paper*, No. 19, on *Béton Aggloméré*.

**407. Uses of beton agglomeré in Europe and elsewhere.** The most important and costly work that has yet been undertaken in this material is a section, thirty-seven miles in length, of the Vanne aqueduct, for supplying water to the city of Paris.

This aqueduct, which traverses the forest of Fontainebleau through its entire length, comprises two and a half to three miles of arches, some of them as much as fifty feet in height, and eleven miles of tunnels, nearly all constructed of the material excavated, the impalpable sand of marine formation known under the generic name of Fontainebleau sand. It includes, also, eight or ten bridges of large span (seventy-five to one hundred and twenty-five feet) for the bridging of rivers, canals, and highways.

The smaller arches are full centre, and are generally of a uniform span of  $39\frac{37}{100}$  feet, with a thickness at the crown of  $15\frac{1}{2}$  inches. Their construction was carried on without interruption through the winter of 1868-'69 and the following summer, and the character of the work was not affected by either extreme of temperature. The spandrels are carried up in open work to the level of the crown, and upon the arcade thus prepared the aqueduct pipe is moulded in the same material, the whole becoming firmly knit together into a perfect monolith. The pipe is circular,  $6\frac{1}{2}$  feet in interior diameter, with a thickness of 9 inches at the top, and 12 inches at the sides, at the water surface. The construction of the arches is carried on about two weeks in advance of work on the pipe, and the centres are struck about a week later.

Water was let into a portion of this pipe in the spring of 1869, and M. Belgrand, inspector-general of bridges and highways, and director of drainage and sewers of the city of Paris, certified that "*the impermeability appeared complete.*"

**408.** Another interesting application of this material has been made in the construction, completed or very nearly so, of the light-house at Port Said, Egypt. It will be one hundred and eighty feet high, without joints, and resting upon a monolithic block of béton, containing nearly four hundred cubic yards.

**409.** An entire Gothic church, with its foundations, walls, and steeple in a single piece, has been built of this material at Vesinet, near Paris. The steeple is one hundred and

thirty feet high, and shows no cracks or other evidences of weakness.

M. Pallu, the founder, certifies that "during the two years consumed by M. Coignet in the building of this church, the *béton aggloméré*, in all its stages, was exposed to rain and frost, and that it has perfectly resisted all variations of temperature."

The entire floor of the church is paved with the same material, in a variety of beautiful designs, and with an agreeable contrast of colors.

410. In constructing the municipal barracks of Notre Dame, Paris, the arched ceilings of the cellars were made of this *béton*, each arch being a single mass. The spans varied from twenty-two to twenty-five feet, the rise, in all cases, being one-tenth the span, and the thickness at the crown 8.66 inches. In the same building the arched ceilings of the three stories of galleries, one above the other, facing the interior, and all the subterranean drainage, comprising nearly six hundred yards of sewers, are also monoliths of *béton*.

411. Over thirty-one miles of the Paris sewers had been laid in this material prior to June, 1869, at a saving of 20 per cent., on the lowest estimated cost, in any other kind of masonry.

The composition of the *béton* was as follows:—

Sand, 5 measures.

Hydraulic lime, 1 measure.

Paris cement (said to be as good as Portland cement),  $\frac{1}{2}$  measure.

412. The works above referred to were visited by the writer in the month of February, 1870, and these statements are based upon close observation and personal knowledge.

Many other interesting applications of this material were examined, of which it is not deemed necessary to make any special mention, except that in combined stability, strength, beauty, and cheapness they far surpass the best results that could have been achieved by the use of any other materials, whether stone, brick, or wood.

In the numerous and varied applications which have been made of it in France, it has received the most emphatic commendations from the government engineers and architects.

413. Its superiority to Rosendale concrete for common work, such as foundations, the backing and hearting of walls, magazine walls, and generally for all masonry protected by earth, and therefore not necessarily required to be of first

quality, lies in its possessing greater strength and hardness at the same cost, and consequently in its being proportionately cheaper when reduced to the same strength by increasing the proportion of sand.

414. Sea-water is nearly as good as fresh water for mixing Portland cements, but injures the Rosendale and all argillo-magnesian cements very considerably.

415. It is of great importance that the incorporation of the lime with the cement should be very thorough, in order to insure a perfectly homogeneous mixture, and this can be obtained with greater certainty by triturating the two together into a thick, viscous paste before the sand is added. In conducting extensive operations the use of two mills of different sizes would perhaps be advantageous, the smaller one being employed exclusively in the preparation of the matrix.

The following proportions may be relied upon to give Coignet bétons of good average quality:—

	1	2	3	4
Coarse and fine sand, by measure . . . . .	6	6½	7	7½
Portland cement, by measure . . . . .	1	1	1	1
Common lime-powder, by measure . . . . .	⅓	½	¾	⅞

416. For foundations and other plain massive work not exposed to view, or where a smooth surface is not specially desired, a liberal amount of gravel and pebbles, or broken stone, may be added to all of the bétons of the above table.

The following proportions will answer for such purposes:—

	1	2	3	4
Coarse and fine sand, by measure . . . . .	6	6½	7	7½
Gravel and pebbles, by measure . . . . .	12	13	13	14
Portland cement, by measure . . . . .	1	1	1	1
Common lime-powder, by measure . . . . .	⅓	½	¾	⅞

See *General Gilmore's Report*.

## V.

## FOUNDATIONS OF STRUCTURES ON LAND.

417. The term *foundation* is used indifferently either for the lower courses of a structure of masonry, or for the artificial arrangement, of whatever character it may be, on which these courses rest. For more perspicuity, the term *bed of the foundation* will be used in this work when the latter is designated.

418. The strength and durability of structures of masonry depend essentially upon the bed of the foundation. In arranging this, regard must be had not only to the permanent efforts which the bed may have to support, but to those of an accidental character. It should, in all cases, be placed so far below the surface of the soil on which it rests, that it will not be liable to be uncovered, or exposed; and its surface should not only be normal to the resultant of the efforts which it sustains, but this resultant should intersect the base of the bed so far within it, that the portion of the soil between this point of intersection and the outward edge of the base shall be broad enough to prevent its yielding from the pressure thrown on it.

419. The first preparatory step to be taken, in determining the kind of bed required, is to ascertain the nature of the subsoil on which the structure is to be raised. This may be done, in ordinary cases, by sinking a pit; but where the subsoil is composed of various strata, and the structure demands extraordinary precaution, borings must be made with the tools usually employed for this purpose.

420. **Classification of Soils.**—With respect to foundations, soils are usually divided into three classes:

The 1st class consists of soils which are incompressible, or, at least, so slightly compressible, as not to affect the stability of the heaviest masses laid upon them, and which, at the same time, do not yield in a lateral direction. Solid rock, some tufas, compact stony soils, hard clay which yields only to the pick or to blasting, belong to this class.

The 2d class consists of soils which are incompressible, but require to be confined laterally, to prevent them from spreading out. Pure gravel and sand belong to this class.

The 3d class consists of all the varieties of compressible soils; under which head may be arranged ordinary clay, the

common earths, and marshy soils. Some of this class are found in a more or less compact state, and are compressible only to a certain extent, as most of the varieties of clay and common earth; others are found in an almost fluid state, and yield, with facility, in every direction.

**421. Foundations on Rock.**—To prepare the bed for a foundation on rock, the thickness of the stratum of rock should first be ascertained, if there are any doubts respecting it: and if there is any reason to suppose that the stratum has not sufficient strength to bear the weight of the structure, it should be tested by a trial weight, at least twice as great as the one it will have to bear permanently. The rock is next properly prepared to receive the foundation courses by levelling its surface, which is effected by breaking down all projecting points, and filling up cavities, either with rubble masonry or with béton; and by carefully removing any portions of the upper stratum which present indications of having been injured by the weather. The surface, prepared in this manner, should, moreover, be perpendicular to the direction of the pressure; if this is vertical, the surface should be horizontal, and so for any other direction of the pressure. Should there, however, be any difficulty in so arranging the surface as to have it normal to the resultant of the pressure, it may receive a position such that one component of the resultant shall be perpendicular to it, and the other parallel; the latter being counteracted by the friction and adhesion between the base of the bed and the surface of the rock. If, owing to a great declivity of the surface, the whole cannot be brought to the same level, the rock must be broken into steps, in order that the bottom courses of the foundation throughout, may rest on a surface perpendicular to the direction of the pressure. If fissures or cavities are met with, of so great an extent as to render the filling them with masonry too expensive, an arch must then be formed, resting on the two sides of the fissure, to support that part of the structure above it.

The slaty rocks require most care in preparing them to receive a foundation, as their top stratum will generally be found injured to a greater or less depth by the action of frost.

**422. Foundations in Stony Ground.**—In stony earths and hard clay, the bed is prepared by digging a trench wide enough to receive the foundation, and deep enough to reach the compact soil which has not been injured by the action of frost; a trench from 4 to 6 feet will generally be deep enough for this purpose.

**423.** In compact gravel and sand, where there is no lia

bility to lateral yielding, either from the action of rain or any other cause, the bed may be prepared as in the case of stony earths. If there is danger from lateral yielding, the part on which the foundation is to rest must be secured by confining it laterally by means of sheeting piles, or in any other way that will offer sufficient security.

**424. Foundations on Sand.**—In laying foundations on firm sand, a further precaution is sometimes resorted to, of placing a platform on the bottom of the trench, for the purpose of distributing the whole weight more uniformly over it. This, however, seems to be unnecessary; for if the bottom courses of the masonry are well settled in their bed, there is no good reason to apprehend any unequal settling from the effect of the superincumbent weight: whereas, if the wood of the platform should, by any accident, give way, it would leave a part of the foundation without any support.

When the sand under the bed is liable to injury from springs they must be cut off, and a platform, or, still better, an area of béton, should compose the bed, and this should be confined on all sides between walls of stone, or béton sunk below the bottom of the bed.

**425. Precautions against Water.**—If, in opening a trench in sand, water is found at a slight depth, and in such quantity as to impede the labors of the workmen, and the trench cannot be kept dry by the use of pumps or scoops, a row of sheeting piles must be driven on each side of the space occupied by it, somewhat below the bottom of the bed, the sand on the outside of the sheeting piles be thrown out, and its place filled with a puddling of clay, to form a water-tight enclosure round the trench. The excavation for the bed is then commenced; but if it be found that the water still makes rapidly at the bottom, only a small portion of the trench must be opened, and after the lower courses are laid in this portion, the excavation will be gradually effected, as fast as the workmen can execute the work, without difficulty from the water.

**426. Foundations in Compressible Soils.** The beds of foundations in compressible soils require peculiar care, particularly when the soil is not homogeneous, presenting more resistance to pressure in one point than in another; for, in that case, it will be very difficult to guard against unequal settling.

**427.** In ordinary clay, or earth, a trench is dug of the proper width, and deep enough to reach a stratum beyond the action of frost; the bottom of the trench is then levelled off

to receive the foundation. This may be laid immediately on the bottom, or else upon a *grillage* and *platform*. In the first case, the stones forming the lowest course should be firmly settled in their beds, by ramming them with a very heavy beetle. In the second a timber grating, termed a *grillage* (Fig. 30), which is formed of a course of heavy beams laid lengthwise in the trench, and connected firmly by cross pieces into which they are notched, is firmly settled in the bed, and the earth is solidly packed between the longitudinal and cross pieces; a flooring of thick planks, termed a *platform*, is then laid on the *grillage*, to receive the lowest course

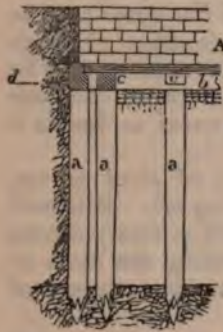

Fig. 30 represents the arrangement of a *grillage* and *platform* fitted on piles.

A, masonry.  
aa, piles.  
b, string-pieces.  
c, cross pieces.  
d, capping-piece.  
e, platform of plank.

of the foundation. The object of the *grillage* and *platform* is to diffuse the weight more uniformly over the surface of the trench, to prevent any part from yielding.

428. Repeated failures in *grillages* and *platforms*, arising either from the compression of the woody fibre or from a transversal strain occasioned by the subsoil offering an unequal resistance, have impaired confidence in their efficacy. Engineers now prefer beds formed of an area of *béton*, as offering more security than any bed of timber, either in a uniformly or unequally compressible soil.

429. The preparation of an area of *béton* for the bed of a foundation, will depend on the circumstances of the case. In ordinary cases the *béton* is thrown into the trench, and carefully rammed in layers of 6 or 9 inches, until the mortar collects in a semi-fluid state on the top of the layer. If the base of the bed is to be broader than the top, its sides must be confined by boards suitably arranged for this purpose. Whenever a layer is left incomplete at one end, and another is laid upon it, an offset should be left at the unfinished ex-



tremity, for the purpose of connecting the two layers more firmly when the work on the unfinished part is resumed.

Considerable economy may be effected, in the quantity of *béton* required for the bed, by using large blocks of stone which should be so distributed throughout the layer that the beetle will meet with no difficulty in settling the *béton* between and around the blocks.

When springs rise through the soil over which the *béton* is to be spread, the water from them must either be conveyed off by artificial channels, which will prevent it rising through the mass of *béton* and washing out the lime; or else strong cloth, prepared so as to be impermeable to water, may be laid over the surface of the soil to receive the bed of *béton*.

The artificial channels for conveying off the water may be formed either of stone blocks with semi-cylindrical channels cut in them, or of semi-cylinders of iron, or tiles, as may be most convenient. A sufficient number of these channels should be formed to give an outlet to the water as fast as it rises.

An impermeable cloth may be formed of stout canvas, prepared with bituminous pitch and a drying oil. It is well to have the cloth doubled on each side with ordinary canvas to prevent accidents. The manner of settling the cloth on the surface of the soil must depend on the circumstances of the case.

Each of the foregoing expedients for preventing the action of springs on an area of *béton* has been tried with success. When artificial channels are used, they may be completely choked subsequently, by injecting into them a semi-fluid hydraulic cement, and the action of the springs be thus destroyed.

Foundation beds of *béton* are frequently made without exhausting the water from the area on which they are laid. For this purpose the *béton* is thrown in layers over the area, by using either a wooden conduit reaching nearly to the position of the layer, or else by placing the *béton* (Fig. 31) in a box by which it is lowered to the position of the layer, and from which it is deposited so as not to permit the water to separate the lime from the other ingredients.

A conduit for immersing hydraulic concrete, formed of boiler iron, has been used on some of our public works. The body of it is cylindrical, and made in sections which can be readily successively fastened on or detached; the bottom, having the form of a conical frustum, is fastened to the lowest section of the body. The conduit is suspended vertically

from a movable crane, or crab engine, by a strong screw, by which it can be raised or lowered, so as to admit the concrete to escape from the body through the conical-shaped end, to be spread and compressed by the movements of the crane and screw.

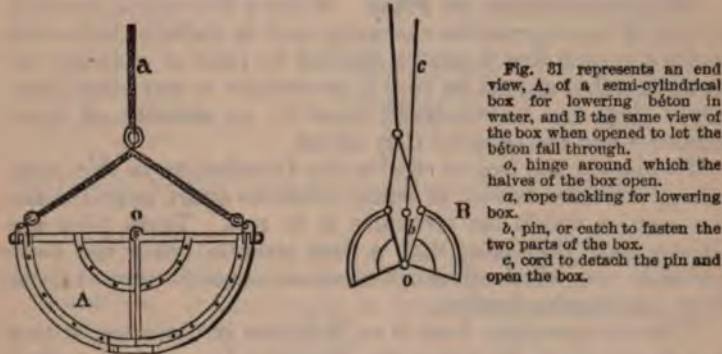

Should it be found that springs boil up at the bottom, it must be covered with an impermeable cloth.

**430. Foundations in Marshy Soils.** In marshy soils the principal difficulty consists in forming a bed sufficiently firm to give stability to the structure, owing to the yielding nature of the soil in all directions.

The following are some of the dispositions that have been tried with success in this case. Short piles from 6 to 12 feet long, and from 6 to 9 inches in diameter, are driven into the soil as close together as they can be crowded, over an area considerably greater than that which the structure is to occupy. The heads of the piles are accurately brought to a level to receive a grillage and platform; or else a layer of clay, from 4 to 6 feet thick, is laid over the area thus prepared with piles, and is either solidly rammed in layers of a foot thick, or submitted to a very heavy pressure for some time before commencing the foundations. The object of preparing the bed in this manner is to give the upper stratum of the soil all the firmness possible, by subjecting it to a strong compression from the piles; and when this has been effected, to procure a firm bed for the lowest course of the foundation by the grillage, or clay bed; by these means the whole pressure will be uniformly distributed throughout the entire area. This case is also one in which a bed of béton would replace, with great advantage, either the one of clay, or the grillage.

The purposes to which the short piles are applied in this case is different from the object to be attained usually in the employment of piles for foundations ; which is to transmit the weight of the structure that rests on the piles, to a firm incompressible soil, overlaid by a compressible one, that does not offer sufficient firmness for the bed of the foundation.

**431. Foundations on Piles.** When a firm soil is overlaid by one of a compressible character, and its distance below the surface is such that it can be reached by piles of ordinary dimensions, they should be used in preference to any other plan, when they can be rendered durable, on account of their economy and the security they afford.

To prepare the bed to receive the foundations in this case, strong piles are driven, at equal distances apart, over the entire area on which the structure is to rest. These piles are driven until they meet with a firm stratum below the compressible one, which offers sufficient resistance to prevent them from penetrating farther.

Piles are generally from 9 to 18 inches in diameter, with a length not above 20 times the diameter, in order that they may not bend under the stroke of the ram. They are prepared for driving by stripping them of their bark, and paring down the knots, so that the friction, in driving, may be reduced as much as possible. The head of the pile is usually encircled by a strong hoop of wrought iron, to prevent the pile from being split by the action of the ram. The foot of the pile may receive a *shoe* formed of ordinary boiler iron, well fitted and spiked on ; or a cast-iron shoe of a suitable form for penetrating the soil may be cast around a wrought-iron bolt, by means of which it is fastened to the pile.



Fig. 32 represents a section through the axis of a cast-iron shoe and wrought-iron bolt for a pile.

**432. Screw Piles.** In localities where it has been found impracticable to resort to any of the usual means of foundations, as on sandpits, or on beds of a soft conglomerate formed of shells, clay, and the oxide of iron, such as are found on our Southern coasts, iron screw piles have been used with success particularly for light-house structures of iron.

These piles have the screws of different forms according to the soil they are to be used in. The point being little or nothing, and the thread of the screw very broad, for loose

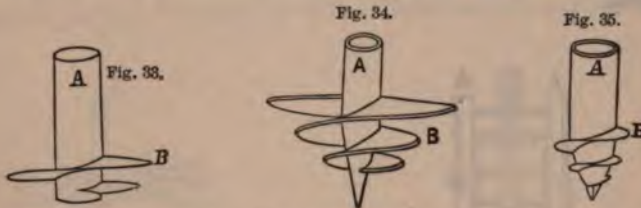

Figs. 33, 34, 35. Elevations of screw piles for loose, firm and hard or rocky soil respectively. A, newel; B, thread of screw.

soils; the point becoming sharper and the thread of the screw more narrow as the soil becomes harder.

**Disk Piles.** In some parts of India this species of pile has been advantageously employed.

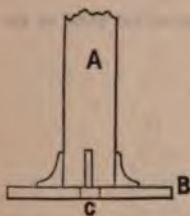

Fig. 36. Elevation of a disk pile. A, shaft; B, disc; C, water-hole.

These piles are made hollow of iron, and have a circular disk attached to the foot. A hole is made in the disk to allow water to pass through.

**Pile Engines.** A machine, termed a *pile engine*, is used for driving piles. It consists essentially of two uprights firmly connected at top by a cross piece, and of a *ram*, or *monkey* of cast iron, for driving the pile by a force of percussion. Two kinds of engines are in use; the one termed a *crab engine*, from the machinery used to hoist the ram to the height from which it is to fall on the pile; the other the *ringing engine*, from the monkey being raised by the sudden pull of several men upon a rope, by which the ram is drawn up a few feet to descend on the pile.

The crab engine is by far the more powerful machine, but on this account is inapplicable in some cases, as in the driving

of cast-iron piles, where the force of the blow might destroy the pile; also in long slender piles it may cause the pile to spring so much as to prevent it from entering the subsoil.

The *steam pile driver* is but a modification of the *crab engine*.

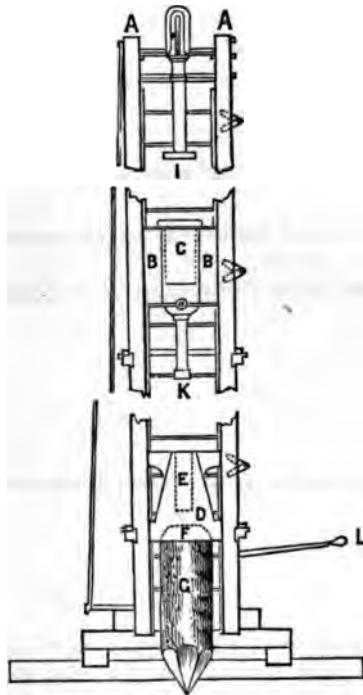

Fig. 37 represents a front elevation of the gunpowder pile driver.

- A, guides.
- B, ram.
- C, socket in which piston I fits.
- D, cast-iron cylinder containing powder chamber E.
- F, socket to fit on head of pile.
- G, pile.
- H, plunger of ram.
- I, lever to hold ram at any point on the guides.

Shaw's *gunpowder pile driver* consists essentially of two uprights or guides, between which are placed the ram and powder chamber. The latter consists of a cast-iron cylinder, having a socket in its lower end, and a powder chamber at the upper. The ram differs from that in ordinary use only by having a plunger made to fit the powder chamber, at the bottom, and a cylindrical cavity at top, extending about half way down. At any convenient point on the guides is placed a piston made to fit into the ram, to take the place of an air-cushion in taking up the recoil, in case the charge should be too great.

Work is begun by placing the powder chamber on top of

the pile to be driven, putting a cartridge in the chamber, and allowing the ram to fall. The explosion of the cartridge throws the ram up and drives the pile down proportionally. Another cartridge is thrown in and the operation repeated. The only limit to the rapidity of the blows is the size of the cartridges and the rapidity with which they are supplied.



Fig. 88 represents the capstan for driving screw piles by hand.

- A, shaft of pile.
- B, screw.
- C, capstan.
- D, taper of shaft to fit into socket of next section above.
- E, bolt fastening socket of shaft to taper of next section below.

For driving screw-piles a capstan is fitted to the head of the pile, and motion communicated to the pile either by men taking hold of the capstan bars and walking around with them, or by attaching an endless rope or chain to the extremities of the bars, and setting it in motion by machinery.

For setting disk-piles, water is forced down through the hole in the disk, and produces a scour from under the pile which gradually sinks to its place.

The manner of driving piles, and the extent to which they may be forced into the subsoil, will depend on local circumstances. It sometimes happens that a heavy blow will effect less than several slighter blows, and that piles after an interval between successive volleys of blows can with difficulty be

started at first. In some cases the pile breaks below the surface, and continues to yield to the blows by the fibres of the lower extremity being crushed. These difficulties require careful attention on the part of the engineer. Piles should be driven to an unyielding subsoil. The French civil engineers have, however, adopted a rule to stop the driving when the pile has arrived at its *absolute stoppage*, this being measured by the further penetration into the subsoil of about  $\frac{2}{10}$ ths of an inch, caused by a volley of thirty blows from a ram of 800 lbs., falling from a height of 5 feet at each blow.

433. If the head of a pile has to be driven below the level to which the ram descends, another pile, termed a *punch*, is used for the purpose. A cast-iron socket of a suitable form embraces the head of the pile and the foot of the punch, and the effect of the blow is thus transmitted through the punch to the pile.

434. When a pile, from breaking or any other cause, has to be drawn out, it is done by using a long beam as a lever for the purpose; the pile being attached to the lever by a chain or rope, suitably adjusted.

435. The number of piles required will be regulated by the weight of the structure. Where the piles are driven to a firm subsoil, they may be subjected to a working strain of 1000 pounds to the square inch of cross section at top. In the contrary case, and where the resistance offered results mainly from that of friction on the exterior of the piles, the working strain should be reduced to 200 pounds to the square inch. The least distance apart at which the piles can be driven with ease is about  $2\frac{1}{2}$  feet between their centres. If they are more crowded than this, they may force each other up as they are successively driven. When this is found to take place, the driving should be commenced at the centre of the area, and the pile should be driven with the butt end downward.

436. From experiments carefully made in France, it appears that piles which resist only in virtue of the friction arising from the compression of the soil, cannot be subjected with safety to a load greater than one-fifth of that which piles of the same dimensions will safely support when driven into a firm soil.

437. After the piles are driven, they are sawed off to a level, to receive a grillage and platform for the foundation. A large beam, termed a *capping*, is first placed on the heads of the outside row of piles, to which it is fastened by means of wooden pins, or *tree-nails*, driven into an auger-hole made

through the cap, into the head of each pile. After the cap is fitted, longitudinal beams, termed *string-pieces*, are laid lengthwise on the heads of each row, and rest at each extremity on the cap, to which they are fastened by a dove-tail joint and a wooden pin. Another series of beams, termed *cross-pieces*, are laid crosswise on the string-pieces, over the heads of each row of piles. The cross and string pieces are connected by a notch cut into each, so that, when put together, their upper surfaces may be on the same level, and they are fastened to the heads of the piles in the same manner as the capping. The extremities of the cross-pieces rest on the capping, and are connected with it like the string-pieces.

The platform is of thick planks laid over the grillage, with the extremity of each plank resting on the capping, to which, and to the string and cross pieces, the planks are fastened by nails.

The capping is usually thicker than the cross and string pieces by the thickness of the plank; when this is the case, a rabbet, about four inches wide, must be made on the inner edge of the capping, to receive the ends of the planks.

438. An objection is made to the platform as a bed for the foundation, owing to the want of adhesion between wood and mortar; from which, if any unequal settling should take place, the foundations would be exposed to slide off the platform. To obviate this, it has been proposed to replace the grillage and platform by a layer of *béton* resting partly on the heads of the piles, and partly on the soil between them. This means would furnish a firm bed for the masonry of the foundations, devoid of the objections made to the one of timber.

To counteract any tendency to sliding, the platform may be inclined if there is a lateral pressure, as in the case, for example, of the abutments of an arch.

439. In soils of alluvial formation, it is common to meet with a stratum of clay on the surface, underlaid with soft mud, in which case the driving of short piles would be injurious, as the tenacity of the stratum of clay would be destroyed by the operation. It would be better not to disturb the upper stratum in this case, but to give it as much firmness as possible, by ramming it with a heavy beetle, or by submitting it to a heavy pressure.

The piers of the bridge over the Seekonk river are formed of clusters of piles driven through the mud to a firm subsoil.

These piles are of hard Southern or yellow pine, hewn to twelve or fourteen inches square, according to the size of the



stick, throughout their whole length. They are arranged in groups of twelve, except in five clusters under the draw. Eight of the piles in the clusters of twelve have their outside corners taken off to allow the flanges of the cylinders to pass

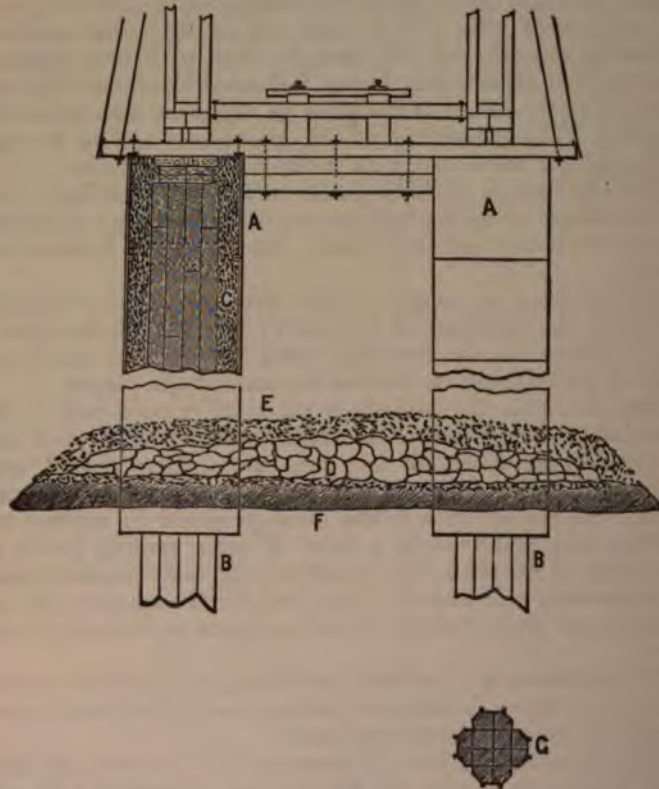

Fig. 30 represents a section and elevation of a pier of the Seekonk river bridge.  
 A, outside cover of metal.  
 B, clusters of wooden piles.  
 C, inside filling of concrete.  
 D, loose stone.  
 E, slag.  
 F, crust of shells.  
 G, cross section of wooden clusters.

down by them. The piles forming each of these clusters are firmly bolted together with inch and a quarter bolts. These clusters are incased with cast-iron cylinders, extending from ten inches above the piling in the draw pier, and sixteen or

twenty inches in the others, to four and six feet below the top of the crust. The cylinders are six and five feet in diameter for the large and small clusters, and the void space left between them and the clusters is filled in with good concrete.

440. Piles and sheeting piles of cast iron have been used with complete success in England, both for the ordinary purposes of cofferdams, and for permanent structures for wharfing. The piles have been cast of a variety of forms; in some cases they have been cast hollow for the purpose of excavating the soil within the pile as it was driven, and thus facilitate its penetration into the subsoil. Fig. 40 represents a horizontal section of one of the more recent arrangements of iron piles and sheeting piles.

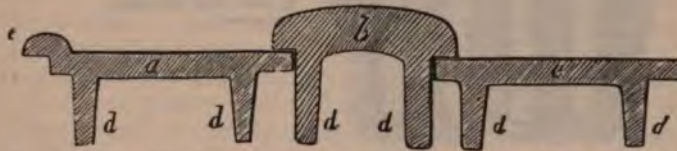

Fig. 40 represents a horizontal section of an arrangement of piles and sheeting piles of cast iron.

a, sheeting pile with a lap *e* to cover the joint between it and the next sheeting pile.  
 b, piles with a lap on each side.  
 c, sheeting pile lapped by pile and sheeting pile next it.  
 d, ribs of piles and sheeting piles.

441. Sand has also been used with advantage to form a bed for foundations in a very compressible soil. For this purpose a trench is (Fig. 41) excavated, and filled with sand; the sand being spread in layers of about 9 inches, and each layer being firmly settled by a heavy beetle, before laying the next. If



Fig. 41 represents a section of a sand foundation bed and the masonry upon it.  
 A, sand bed in a trench.  
 B, masonry.

water should make rapidly in the trench, it would not be practicable to pack the sand in layers. Instead, therefore, of

opening a trench, holes about 6 feet deep, and 6 inches in diameter (Fig. 42), should be made by means of a short pile, as close together as practicable; when the pile is withdrawn from the hole it is immediately filled with sand. To cause the sand to pack firmly, it should be slightly moistened before placing it in the holes or trench.

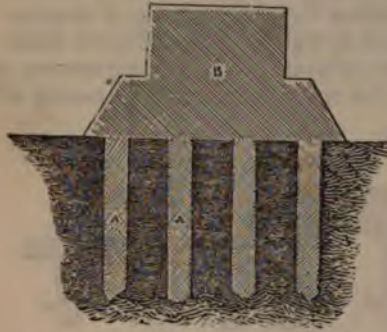

Fig. 42.—Represents a section of a foundation bed made by filling holes with sand.  
A, holes filled with sand.  
B, masonry.

Sand, when used in this way, possesses the valuable property of assuming a new position of equilibrium and stability, should the soil on which it is laid yield at any of its points. Not only does this take place along the base of the sand bed, but also along the edges, or sides, when these are enclosed by the sides of the trench made to receive the bed. This last point offers also some additional security against yielding in a lateral direction. The bed of sand must, in all cases, receive sufficient thickness to cause the pressure on its upper surface to be distributed over the entire base.

442. When, from the fluidity of the soil, the vertical pressure of the structure causes the soil to rise around the bed, this action may be counteracted either by scooping out the soil to some depth around the bed and replacing it by another of a more compact nature, well rammed in layers, or with any rubbish of a solid character; or else a mass of loose stone may be placed over the surface exterior to the bed, whenever the character of the structure will warrant the expense.

443. **Precautions against Lateral Yielding.** The soils which have been termed compressible, strictly speaking, yield only by the displacement of their particles either in a lateral direction, or upward around the structure laid upon them. Where this action arises from the effect of a vertical weight, uniformly distributed over the base of the bed, the preceding

methods for giving permanent stability to structure present all requisite security. But when the structure is subjected also to a lateral pressure, as, for example, that which would arise from the action of a bank of earth resting against the back of a wall, additional means of security are demanded.

One of the most obvious expedients in this case is to drive a row of strong square piles in juxtaposition immediately in contact with the exterior edges of the bed. This expedient is, however, only of service where the piles attain either an incompressible soil, or one at least firmer than that on which the bed immediately rests. For otherwise, as is obvious, the piles only serve to transmit the pressure to the yielding soil in contact with them. But where they are driven into a firm soil below, they gain a fixed point of resistance, and the only insecurity they offer is either by the rupture of the piles, from the cross strain upon them, or from the yielding of the firm subsoil, from the same cause.

In case the piles reach a firm subsoil, it will be best to scoop out the upper yielding soil before driving the piles and to fill in between and around them with loose broken stone (Fig. 43). This will give the piles greater stiffness, and effectually prevent them from spreading at top.

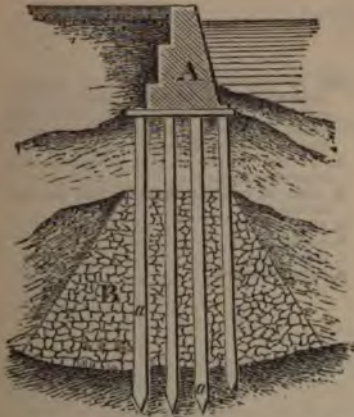

Fig. 43.—Represents the manner of using loose stone to sustain piles and prevent them from yielding laterally.  
A, section of the masonry.  
B, loose stone thrown around the piles, a.

When the piles cannot be secured by attaining a firm subsoil, it will be better to drive them around the area at some distance from the bed, and, as a further precaution, to place horizontal buttresses of masonry at regular intervals from the bed to the piles. By this arrangement some additional security is gained from the counter-pressure of the soil enclosed

between the bed and the wall of piles. But it is obvious that unless the piles in this case are driven into a firmer soil than that on which the structure rests, there will still be danger of yielding.

In using horizontal buttresses, the stone of which they are constructed should be dressed with care; their extremities near the wall of piles should be connected by horizontal arches (Fig. 44), to distribute the pressure more uniformly; and where there is an upward pressure of the soil around the structure, arising from its weight, the buttresses ought to be in the form of reversed arches.

In buttresses of this kind, as likewise in broad areas resting on a very yielding soil, since as much danger is to be apprehended from their breaking by their own weight as from any other cause, it must be carefully guarded against. Something may be done for this purpose by ramming the earth around the structure with a heavy beetle, when it can be made more compact by this means; or else a part of the upper soil may be removed, and be replaced by one of a more compact nature which may be rammed in layers.

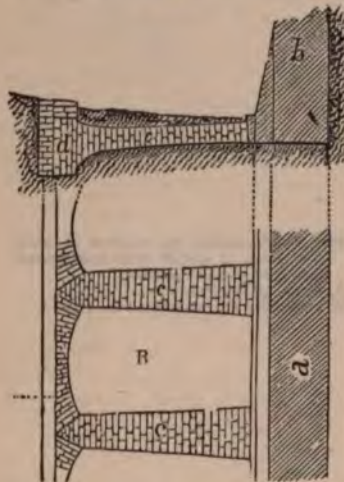

Fig. 44 represents the manner of preventing a sustaining wall from yielding laterally to a thrust behind it, by using horizontal buttresses of reversed arches abutting against vertical counter-arches.

A, vertical section of wall, buttresses, and counter-arches.  
 B, plan of wall, buttresses, and counter-arches.  
 a, plan of wall.  
 b, section of do.  
 c, buttresses.  
 d, counter-arches.

The following methods, where they can be resorted to, and where the character of the structure will justify the expense, have been found to offer the best security in the case in question.

When the bed can be buttressed in front with an embank

ment, a low counter-wall (Fig. 45) may be built parallel to the edge of the bed, and some 10 or 12 feet from it; between this wall and the bed a reversed arch connecting the two may be built, and a surcharge of earth of a compact character and well rammed, may be placed against the counter-wall to act by its counter-pressure against the lateral pressure upon the bed.

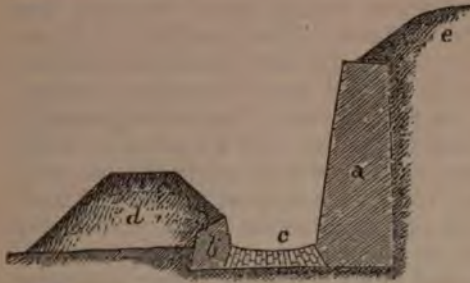

Fig. 45 represents the manner of buttressing a sustaining wall in front by the action of a counter-pressure of earth transmitted to the wall by a reversed arch.  
*a*, section of sustaining wall.  
*b*, section of sustaining wall of embankment, *d*.  
*c*, section of reversed arch.  
*d*, section of embankment from which counter-pressure comes.  
*e*, section of embankment behind sustaining wall.

When the bed cannot be buttressed in front, as in quay walls, a grillage and platform supported on piles (Fig. 46) may be built to the rear from the back of the wall, for the purpose of supporting the embankment against the back of the wall, and preventing the effect which its pressure on the subsoil might have in thrusting forward the bed of the foundation.

In addition to these means, land ties of iron will give great additional security, when a fixed point in rear of the wall can be found to attach them firmly.

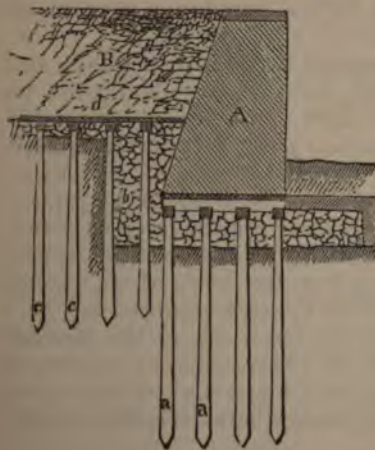

Fig. 46 represents the manner of relieving a sustaining wall from the lateral action caused by the pressure of an embankment on the subsoil by means of a platform built behind the wall.  
*A*, section of the wall.  
*B*, section of embankment.  
*a*, piles supporting the grillage and platform of *A*.  
*b*, loose stone, forming a firm bed under the platform.  
*c*, piles supporting the platform *d* behind the wall.

## VI

## FOUNDATIONS OF STRUCTURES IN WATER.

444. In laying foundations in water, two difficulties have to be overcome, both of which require great resources and care on the part of the engineer. The first is found in the means to be used in preparing the bed of the foundation; and the second in securing the bed from the action of water, to insure the safety of the foundations. The last is generally the more difficult problem of the two; for a current of water will gradually wear away, not only every variety of loose soils, but also the more tender rocks, such as most varieties of sandstone, and the calcareous and argillaceous rocks, particularly when they are stratified, or are of a loose texture.

445. To prepare the bed of a foundation in stagnant water the only difficulty that presents itself is to exclude the water from the area on which the structure is to rest. If the depth of water is not over 4 feet, this is done by surrounding the area with an ordinary water-tight dam of clay, or of some other binding earth. For this purpose, a shallow trench is formed around the area, by removing the soft or loose stratum on the bottom; the foundation of the dam is commenced by filling this trench with the clay, and the dam is made by spreading successive layers of clay about one foot thick, and pressing each layer as it is spread to render it more compact. When the dam is completed, the water is pumped out from the enclosed area, and the bed for the foundation is prepared as on dry land.

446. When the depth of stagnant water is over 4 feet, and in running water of any depth, the ordinary dam must be replaced by the coffer-dam. This construction consists of two rows of plank, termed *sheeting piles*, driven into the soil vertically, forming thus a coffer-work, between which clay or binding earth, termed the *puddling*, is filled in, to form a water-tight dam to exclude the water from the area enclosed.

The arrangement, construction, and dimensions of coffer-dams depend on their specific object, the depth of water, and the nature of the subsoil on which the coffer-dam rests.

With regard to the first point, the width of the dam between the sheeting piles should be so regulated as to serve as a scaffolding for the machinery and materials required about the work. This is peculiarly requisite where the coffer-dam en-

closes an isolated position removed from the shore. The interior space enclosed by the dam should have the requisite capacity for receiving the bed of the foundations, and such materials and machinery as may be required within the dam.

The width or thickness of the coffer-dam, by which is understood the distance between the sheeting piles, should be sufficient not only to be impermeable to water, but to form, by the weight of the puddling, in combination with the resistance of the timber-work, a wall of sufficient strength to resist the horizontal pressure of the water on the exterior, when the interior space is pumped dry. The resistance offered by the weight of the puddling to the pressure of the water can be easily calculated; that offered by the timber-work will depend upon the manner in which the framing is arranged, and the means taken to *stay* or buttress the dam from the enclosed space.

The most simple and the usual construction of a coffer-dam

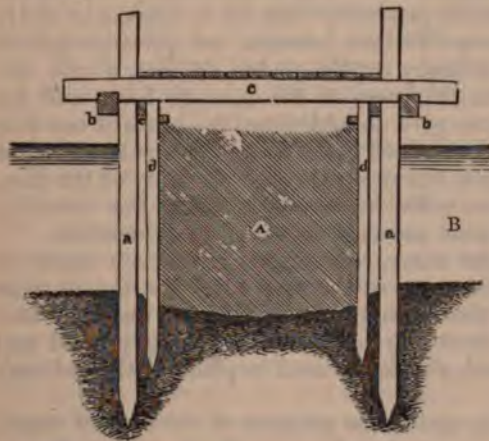

Fig. 47—represents a section of the ordinary coffer-dam.

- a, main piles.
- b, wale or string pieces.
- c, cross pieces.
- d, sheeting piles.
- e, guide string pieces for sheeting piles.
- A, puddling.
- B, interior space.

(Fig. 47) consists in driving a row of ordinary straight piles around the area to be enclosed, placing their centre lines about 4 feet asunder. A second row is driven parallel to the first, the respective piles being the same distance apart; the distance between the centre lines of the two rows being so regulated as to leave the requisite thickness between the sheeting piles for the dam. The piles of each row are connected by a horizontal beam of square timber, termed a *string* or *wale piece*, placed a foot or two above the highest water line, and



notched and bolted to each pile. The string pieces of the inner row of piles are placed on the side next to the area enclosed, and those of the outer row on the outside. Cross beams of square timber connect the string pieces of the two rows upon which they are notched, serving both to prevent the rows of piles from spreading from the pressure that may be thrown on them and as a joisting for the scaffolding. On the opposite sides of the rows interior string pieces are placed, about the same level with the exterior, for the purpose of serving both as guides and supports for the sheeting piles. The sheeting piles being well jointed are driven in juxtaposition, and against the interior string pieces. A third course of string or *ribbon* pieces of smaller scantling confine, by means of large spikes, the sheeting piles against the interior string pieces.

As has been stated, the thickness of the dam and the dimensions of the timber of which the coffer-work is made will depend upon the pressure due to the head of water, when the interior space is pumped dry. For extraordinary depths, the engineer would not act prudently were he to neglect to verify by calculation the equilibrium between the pressure and resistance; but for ordinary depths under 10 feet, a rule followed is to make the thickness of the dam 10 feet; and for depths over 10 feet to give an additional thickness of one foot for every additional depth of three feet. This rule will give every security against filtrations through the body of the dam, but it might not give sufficient strength unless the scantling of the coffer-work were suitably increased in dimensions.

In very deep tidal water, coffer-dams have been made in offsets, by using three rows of sheeting piles for the purpose of giving greater thickness to the dam below the low-water level. In such cases strong square piles closely jointed and tongued and grooved, should be used in place of the ordinary sheeting piles.

Besides providing against the pressure of the head of water, suitable dimensions must be given to the sheeting piles, in order that they may sustain the pressure arising from the puddling when the interior space is emptied of water. This pressure against the interior sheeting piles may be further increased by that of the exterior water upon the exterior sheeting piles, should the pressure of the latter be greater than the former. To provide more securely against the effect of these pressures, intermediate string pieces may be placed against the interior row of piles before the sheeting piles are driven; and the opposite sides of the dam on the interior may

be buttressed by cross pieces reaching across the top string pieces, and by horizontal beams placed at intermediate points between the top and bottom of the dam.

The main inconvenience met with in coffer-dams arises from the difficulty of preventing leakage under the dam. In all cases the piles must be driven into a firm stratum, and the sheeting piles should equally have a firm footing in a tenacious compact substratum. When an excavation is requisite on the interior, to uncover the subsoil on which the bed of the foundation is to be laid, the sheeting piles should be driven at least as deep as this point, and somewhat below it if the resistance offered to the driving does not prevent it.

The puddling should be formed of a mixture of tenacious clay and sand, as this mixture settles better than pure clay alone. Before placing the puddling, all the soft mud and loose soil between the sheeting piles should be carefully extracted; the puddling should be placed in and compressed in layers, care being taken to agitate the water as little as practicable.

With requisite care coffer-dams may be used for foundations in any depth of water, provided a water-tight bottoming can be found for the puddling. Sandy bottoms offer the greatest difficulty in this respect, and when the depth of water is over 5 feet, extraordinary precautions are requisite to prevent leakage under the puddling.

When the depth of water is over 10 feet, particularly where the bottom is composed of several feet of soft mud, or of loose soil, below which it will be necessary to excavate to obtain a firm stratum for the bed of the foundation, additional precautions will be requisite to give sufficient support to the interior sheeting piles against the pressure of the puddling, to provide against leakage under the puddling, and to strengthen the dam against the pressure of the exterior water, when the interior space is pumped dry and excavated. The best means for these ends, when the locality will admit of their application, is to form the exterior of the dam, as has already been described, by using piles and sheeting piles, giving to the latter additional points of support, by intermediate string pieces between the one at top and the bottom of the water; and to form a strong framing of timber for a support to the interior sheeting piles, giving to it the dimensions of the area to be enclosed. The framework (Fig. 48) may be composed of upright square beams, placed at suitable distances apart, depending on the strength required, upon which square string pieces are bolted at suitable distances from the top to the

bottom, the bottom string resting on the surface of the mud. The string pieces, serving as supports for the sheeting piles, must be on the sides of the uprights towards the puddling, and their faces in the same vertical plane. Between each

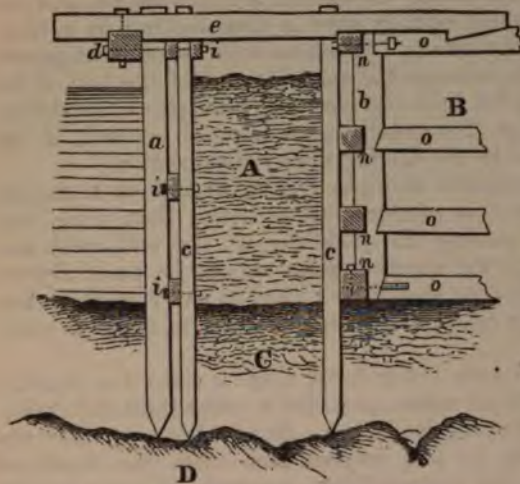

Fig. 48 Represents a section of the cofferdam used for the Potomac aqueduct. a, main exterior piles. b, strong square beams corresponding to a on which the wales n, n are notched and bolted. c, sheeting piles. d, top wale on main piles. e, crosspieces. f, guide and supporting string pieces for sheeting piles. oo, horizontal shores buttressing opposite sides of dam. A, puddling. B, interior space. C, mud, etc. D, rock bottom.

pair of opposite uprights horizontal shores may be placed at the points opposite the position of the string pieces, to increase the resistance of the dam to the pressure of the water; the top shores extending entirely across the dam, and being notched on the top string pieces. The interior shores must be so arranged that they can be readily taken out as the masonry on the interior is built up, replacing them by other shores resting against the masonry itself.

**447. Caisson and Cribwork Cofferdams.** In the construction of the foundations for the piers and abutments of the Victoria tubular iron railroad bridge over the river Saint Lawrence, at Montreal, the engineers had to contend against unusual difficulties; in a rocky bottom covered with boulders, which prevented the use of piles; and in a swift current, bringing down in the spring of the year enormous fields of ice, the effects of which none of the ordinary methods of caisson or coffer-dams could have withstood.

These difficulties were successfully met, in some cases by the use of a large water-tight caisson, shown in plan (Fig. 49), and in cross-section (Fig. 50), of such a form and dimensions as to leave a sufficient interior area, between its interior sides,

for a coffer-dam, and for the ground to be occupied for the construction of the foundations of the pier. In others (Fig 51), where, from the velocity of the current, the caissons, from their great bulk, proved unmanageable, by enclosing the area to be occupied by crib-work, sunk upon the bottom and heavily laden with stone; and exterior to this forming a second similar enclosure; and then, by means of sheeting piles, supported against the opposite sides of these two enclosures, forming a coffer-dam between them.

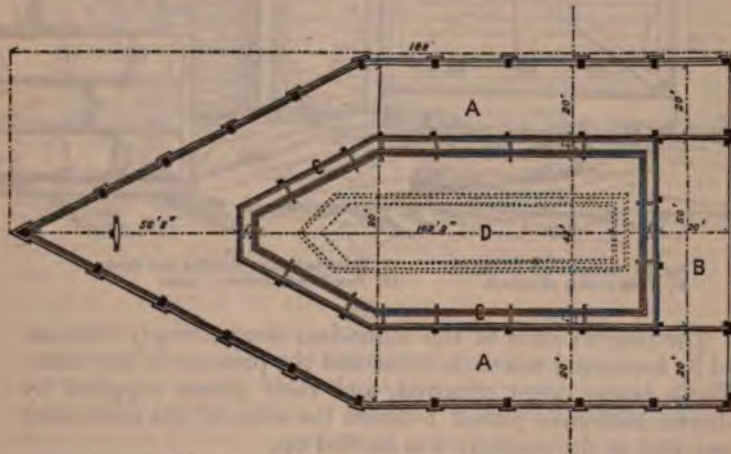

Fig. 49. Plan of caisson. B, Detached end.  
A, A, sides of caisson. C, Puddling.  
D, Plan of pier of bridge.

The caisson (Fig. 49) consisted of two parts, the two sides and up-stream wedge-shaped head, and a rectangular-shaped portion B, which fitted in between the two sides, forming the down-stream end, and which could be detached and floated off when it became necessary to remove the entire caisson.

The caisson (Fig. 50) was flat-bottomed, with vertical sides; and it was provided with a strong flat deck, to receive the workshops, machinery, and materials for pumping, dredging, and the construction of the masonry.

When placed in position, it was moored to a loaded, sunken crib-work up-stream; and, besides the exterior guide-piles, long two-inch iron bolts were inserted into holes drilled into the solid rock, through vertical holes bored through the piles. In this way, through the bearing of the piles on the bottom, the foothold given by the bolts and the mooring-tackle, the

caisson, when sunk, was solidly secured against accidents from rafts, or other floating bodies.



Fig. 50. Cross-section of Fig. 49.  
A', Cross-section of caisson.

C', Cross-section of puddling and sheeting.  
D', Foundation courses of pier.

The interior sides of the coffer-dam were strongly buttressed by horizontal beams, to withstand the pressure of the water. These beams were removed, and their places supplied by shorter buttresses placed between the sides of the coffer-dam and pier as the masonry was carried up.

The cribwork dams were constructed of a number of cribs, each about forty feet in length, which were placed end to end to form the sides of the enclosures, and strongly connected with each other. Some of these were constructed on shore, and towed to their positions. Some were constructed in the water behind mooring cribs, and others upon the ice during the winter, and sunk in position.

A flooring (Fig. 51) was made, about midway between the top and bottom of the cribs, to receive the blocks of stone with which the cribs were loaded, to secure them from the effects of the pressure of the ice in its spring movement, and the collision of floating bodies.

The caissons were not of adequate strength to resist the crush of the ice, and had to be pumped out and removed to a secure position before the closing of the river. The cribs were planked over at top, and remained in place as long as required for the work.

448. When the bed of a river presents a rocky surface, or

rock covered with but a few feet of mud, or loose soil, cases may occur in which it will be more economical and equally safe to lay a bed of béton without exhausting the water from the area to be built on; enclosing the area, before throwing in the béton, by a simple coffer-work formed of a strong



Fig. 51. Cross section of cribwork dams.  
A, Interior crib.

B, Exterior crib.  
C, Puddling and sheeting piles.

framework of uprights and horizontal beams and sheeting piles. The framework (Fig. 52) in this case is composed of uprights connected by string pieces in pairs; each pair is notched and bolted to the uprights, a sufficient interval being left between them for the insertion of the sheeting piles. To secure the framework to the rock, it may be requisite to drill holes in the rock to receive the foot of each upright. The holes may be drilled by means of a long iron bar, termed a *jumper*, which is used for this purpose, or else the ordinary diving-bell may be employed. This machine is very serviceable in all similar constructions where an examination of work under water is requisite, or in cases where it is necessary to lay masonry under water. The framework is put together on land, floated to its position, and settled upon the rock; the sheeting piles are then driven into close contact with the surface of the rock.

449. The convenience and economy resulting from the use of béton for the beds of structures raised in water have led General Treussart to propose a plan for laying beds of this material, and then to take advantage of their strength and impermeability to construct a coffer-dam upon them, in order to carry on the superstructure with more care. To effect this, the space to be occupied by the bed (Fig. 53) is first enclosed by square piles, driven in juxtaposition and secured at top by a string piece. The mud and loose soil are then scooped from the enclosed area to the firm soil on which the

bed of béton is to be laid. The bed of béton is next laid with the usual precautions, and while it is still soft a second row of square piles is driven into it, also in juxtaposition, and

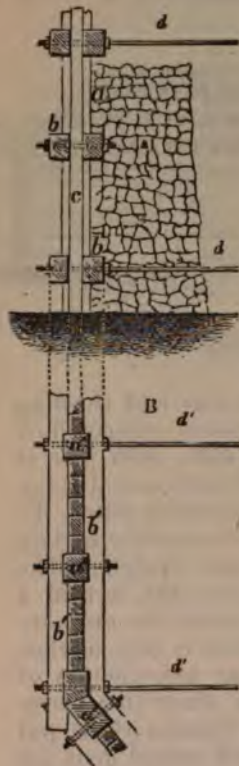

Fig. 52 represents a coffer-work for confining béton.

A, Section of coffer-work and béton.

B, Plan of coffer-work.

*a, a'*, square uprights connected by horizontal beams, *b, b'*, bolted to them in pairs.

*c, c'*, sheeting piles inserted between the beams *b, b'* and the uprights *a, a'*.

*d, d'*, iron rods connecting opposite sides of coffer-work.

at a suitable distance from the first for the thickness of the dam; these are also secured at top by a string piece. Cross pieces are notched upon the string pieces, to secure the rows of piles and form a scaffolding. An ordinary puddling is placed in between the rows of piles, and the interior space is pumped dry.

Should the soil under the bed of béton be permeable, the pressure of the water on the base of the bed may be sufficient to raise the bed and the dam upon it, when the water is taken from the interior space. A proper calculation will show whether this danger is to be apprehended, and should it be,

a provisional weight must be placed on the dam, or the bed of béton, before exhausting the interior.

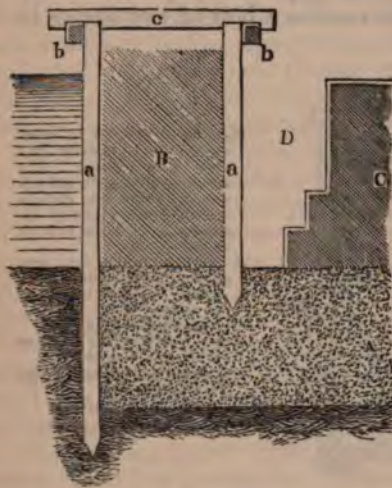

Fig. 53 represents a section of General Treussart's dam.  
 A, bed of béton.  
 B, puddling of dam.  
 C, masonry of structure.  
 a, square piles.  
 b, wale pieces.  
 c, cross piece.

450. When the depth of water is great, or when, from the permeability of the soil at the bottom, it is difficult to prevent leakage, a coffer-dam may be a less economical method of laying foundations than the caisson. The *caisson* (fig. 54.) is a strong water-tight vessel having a bottom of solid heavy timber, and vertical sides so arranged that they can be readily detached from the bottom. The following is the usual arrangement of the caisson, it, like the coffer-dam, being subject to changes to suit it to the locality. The bottom of the caisson, serving as a platform for the foundation course of the masonry, is made level and of heavy timber laid in juxtaposition, the ends of the beams being confined by tenons and screw-bolts to longitudinal capping pieces of larger dimensions. The sides of the box are usually vertical. The sides are formed of upright pieces of scantling covered with thick plank, the seams being carefully calked to make the caisson water-tight. The lower ends of the uprights are inserted into shallow mortises made in the capping. The arrangement for detaching the sides is effected in the following manner: Strong hooks of wrought iron are fixed to the bottom of the caisson at the sides of the capping piece, corresponding to the points where the uprights of the sides are in



serted into this piece. Pieces of strong scantling are laid across the top of the caisson, resting on the opposite uprights, upon which they are notched. These cross pieces project beyond the sides, and the projecting parts are perforated by an auger-hole, large enough to receive a bolt of two inches in

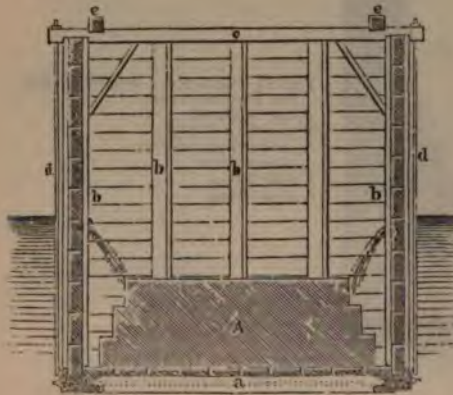

Fig. 54 represents a cross section and interior view of a caisson. The boards in this figure are represented as let into grooves in the vertical pieces, instead of being nailed to them on the exterior.

- a*, bottom beams let into grooves in the capping.
- b*, square uprights to sustain the boards.
- c*, cross pieces resting on *b*.
- d*, iron rods fitted to hooks at bottom and nuts at top.
- e*, longitudinal beams to stay the cross pieces *c*.
- A*, section of the masonry.

diameter. The object of these cross pieces is twofold; the first is to buttress the sides of the caisson at top against the exterior pressure of the water; and the second is to serve as a point of support for a long bolt, or rod of iron, with an eye at the lower end, into which the hook on the capping piece is inserted, and a screw at top, to which a nut or female screw is fitted, and which, resting on the cross pieces as a point of support, draws the bolt tight, and, in that way, attaches the sides and bottom of the caisson firmly together.

A bed is prepared to receive the bottom of the caisson, by levelling the soil on which the structure is to rest, if it be of a suitable character to receive directly the foundation; or by driving large piles through the upper compressible strata of the soil to the firm stratum beneath. The heads of the piles are sawed off on a level to receive the bottom of the caisson.

To settle the caisson on its bed, it is floated to and moored over it; and the masonry of the structure is commenced and carried up, until the weight grounds the caisson. The caisson should be so contrived, that it can be grounded, and afterwards raised, in case that the bed is found not to be accurately levelled. To effect this, a small sliding gate should be placed in the side of the caisson, for the purpose of filling it with

water at pleasure. By means of this gate, the caisson can be filled and grounded, and by closing the gate and pumping out the water, it can be set afloat.

After the caisson is settled on its bed, and the masonry of the structure is raised above the surface of the water, the sides are detached by first unscrewing the nuts and detaching the rods and then taking off the top cross pieces. By first filling the caisson with water, this operation of detaching the sides can be more easily performed.

451. To adjust the piles before they are driven, and to prevent them from spreading outward by the operation of driving, a strong grating of heavy timber, formed by notching cross and longitudinal pieces on each other, and fastening them firmly together, may be resorted to. This grating is arranged in a similar manner to a grillage; only the square compartments between the cross and string pieces are larger, so that they may enclose an area for 4 or 9 piles; and instead of a single row of cross pieces, the grating is made with a double row, one at top, the other at the bottom, embracing the string pieces on which they are notched.

The grating may be fixed in its position at any depth under water, by a few provisional piles, to which it can be attached.

452. Where the area occupied by a structure is very considerable, and the depth of water great, the methods which have thus far been explained cannot be used. In such cases, a firm bed is made for the structure, by forming an artificial island of loose heavy blocks of stone, which are spread over the area, and receive a batter of from one perpendicular to one base, to one perpendicular and six base, according to the exposure of the bed to the effects of waves. This bed is raised several feet above the surface of the water, according to the nature of the structure, and the foundation is commenced upon it.

453. It is important to observe, that, where such heavy masses are laid upon an untried soil, the structure should not be commenced before the bed appears entirely to have settled; nor even then if there be any danger of further settling taking place from the additional weight of the structure. Should any doubts arise on this point, the bed should be loaded with a provisional weight, somewhat greater than that of the contemplated structure, and this weight may be gradually removed, if composed of other materials than those required for the structure, as the work progresses.

454. To give perfect security to foundations in running water, the soil around the bed must be protected to some ex-

tent from the action of the current. The most ordinary method of effecting this is by throwing in loose masses of broken stone of sufficient size to resist the force of the current. This method will give all required security, where the soil is not of a shifting character, like sand and gravel. To secure a soil of this last nature, it will in some cases be necessary to scoop out the bottom around the bed to a depth of from 3 to 6 feet, and to fill this excavated part with béton, the surface of which may be protected from the wear arising from the action of the pebbles carried over it by the current, by covering it with broad flat flagging stones.

455. When the bottom is composed of soft mud to any great depth, it may be protected by enclosing the area with sheeting piles, and then filling in the enclosed space with fragments of loose stone. If the mud is very soft, it would be advisable, in the first place, to cover the area with a grillage, or with a layer of brushwood laid compactly, to serve as a bed for the loose stone, and thus form a more stable and solid mass.

456. **Pneumatic Processes.**—By this term we understand those methods of obtaining foundations in water, in which external or internal atmospheric pressure is the active agent.

These processes are divided into two classes, viz.: the *plenum pneumatic* and the *vacuum pneumatic*, the former term being applied to the case where the pressure of condensed air is employed to drive the water out, and the latter, where the pressure of the atmosphere is employed to drive the water into a vacuum.

457. **Pneumatic Piles.**—This appellation has been given to cylinders of cast-iron, used in the place of ordinary piles to reach a firm subsoil below the bed of a river, suitable for the character of the superstructure to rest upon it, which, being made air-tight on the sides and top, but left open at the bottom, are sunk to the required depth, by rapidly withdrawing the air within them, by methods to be described, and thus causing the water to rush in through the open bottom, removing in its flow the subsoil in contact with the lower end of the cylinder, and allowing it to sink by its own weight, thus belonging to the vacuum pneumatic class.

The cylinders are cast and put together very much in the same manner as ordinary water-pipes; being composed of lengths of from six to ten feet, each of which has an interior flange at each end, with holes for screw-bolts, by means of which and a disk of india-rubber, inserted between the connecting flanges, the joints are made air and water tight.

In the first essays at this mode of foundation, the cylinders were sunk by simply exhausting the internal air, in the ordinary way, above the water-level. The results, however, were not satisfactory, as the pile sunk very slowly.

The next step (Fig. 55) was to connect an air-tight cylindrical vessel, D, by means of a tube A, with a stop-cock, with the interior of the pile A, and also with the air-pump, by another tube leading to the pump from the other end. In order to sink the pile, the communication between it and the exhaust chamber D was first closed, and that between this chamber and air-pump opened. The air was then drawn from D until a sufficient vacuum was produced, when the

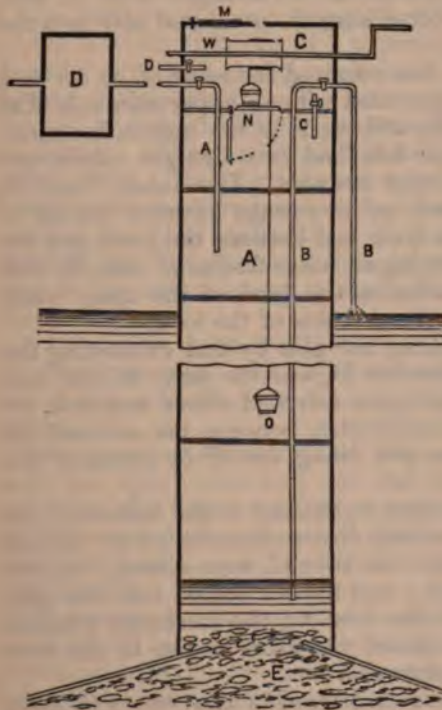

Fig. 55.—Longitudinal section of a pneumatic pile A, air-lock C, and exhaust vessel D.  
 A, exhaust tube between A and D.  
 B, water discharge-tube.  
 C, equilibrium tube between the lock and chamber of the pile.  
 D, equilibrium tube between lock and exterior air.  
 M, upper man-hole and valves.  
 N, lower man-hole and valves.  
 W, windlass and gearing.  
 E, concrete underpinning as practised at Harlem bridge.

communication with the pump was closed, and that with the pile opened, allowing the air to flow from it into the chamber with considerable velocity. This sudden disturbance of the equilibrium between the external and internal pressures on the

pile caused it to descend instantaneously and rapidly, as if struck on the top by a heavy blow, the descent continuing frequently many feet until an equilibrium among the forces was restored.

When the resistance to the further descent of the pile was found to be too great, either from some obstruction met with at the bottom, or from the tenacity of the soil itself, the ingenious expedient was hit upon to force the water from within the pile, by pumping air into it, and thus enable workmen to descend to the bottom and remove the soil or other obstruction to the descent. The plan devised for this purpose was to fit another air-tight iron cylindrical vessel C to the top of the pile, of sufficient diameter and height to hold several workmen, and a windlass W, arranged with an endless rope and buckets for raising the excavated soil into the chamber C.

The chamber, which has received the name of an *air-lock* from its functions, was provided with an upper man-hole M at top for entering the lock, and one N in the bottom for entering the pile. Each man-hole had two air-tight valves, one opening outwards, the other inwards. Two tubes, C and D, with stop-cocks, furnished an air-passage between the air of the pile and that of the lock, and between the latter and the external air. A syphon-shaped water-discharge tube B, with a stop-cock, leads from below the level of the inner water surface through the bottom and side of the lock.

The operation of sinking the pile by first exhausting the air from the exhaust chamber D, was the same in this case as in the preceding; the upper valves of either man-hole being closed, and all communication between the external air and the interior of the pile being cut off by means of the stop-cocks.

When it became necessary to descend to the bottom of the pile, to remove the soil or any obstruction, the lower valve of the lower man-hole, with the tube C, were closed; the discharge tube, B, left open; and the air forced into the pile, by the pumps, through the tube A; the increased pressure upon the water surface caused the water to rise in the tube B, and flow out at the other end.

When all the water was discharged in this way, the lower valve of the upper man-hole, and tubes A, B, and D were closed; the tube C was then opened, through which the condensed air in the pile flowed into the lock, until the density of the air in it and in the pile became the same; the lower valve of the lower man-hole was then opened, to allow the

workmen to descend, and the excavated soil to be raised into the lock-chamber.

To take the excavated material out of the lock, the lower man-hole under valve and the tube C are closed, and the tube D opened; the condensed air of the lock flows out, and the upper man-hole lower valve is opened.

In some of the more recent cases of the application of pneumatic piles, the exhaust-chamber and the discharge water-pipe have been suppressed; condensed air being alone used, both to force the internal water out through the open bottom of the pile, to allow the workmen to excavate within, and also to produce a scour below the lower end, from the rush of the water back into the pile, by allowing the condensed air to escape rapidly from it. For this purpose a tube leads from the air-pumps through the side and bottom of the air-lock, into the pile, to supply the compressed air. Another pipe with a stop-cock leads through the side and bottom of the lock, from the external air to the interior of the pile, through which the condensed air in the pile can be discharged. The upper and lower man-holes have each an under valve. Two equilibrium-tubes with stop-cocks, one forming a connection between the interior of the pile and the air-lock, the other leading through the side of the lock to the external air, furnish the means of bringing the air of the lock to the same density as that within the pile, or that of the atmosphere.

To force out the water, the lower man-hole, the condensed air discharge pipe, and the condensed air equilibrium-tube are closed, and the air then forced into the pile by the pumps.

To excavate the internal soil, the workmen enter the lock, close the upper man-hole and the upper equilibrium-tube, and open the lower equilibrium-tube. This establishes an equilibrium between the air of the lock and that of the pile, and the workmen can then descend into the pile and excavate the soil.

To remove the excavated soil which has been raised into the lock, the lower man-hole and lower equilibrium-tube are closed, and the upper equilibrium-tube opened, which establishes an equilibrium between the air of the lock and that of the atmosphere. The upper man-hole then being opened, the material in the lock can be carried out.

To produce a scour under the pile to allow it to sink, the workmen leave the pile and lock; the condensed air discharge-pipe is then opened, and by the rush of the water

into the pile all obstruction to the movement of the pile is removed from its lower end.

458. **Double Air-Locks.** In some of the more recent applications of condensed air in Europe, air-locks in pairs have been used to save time.

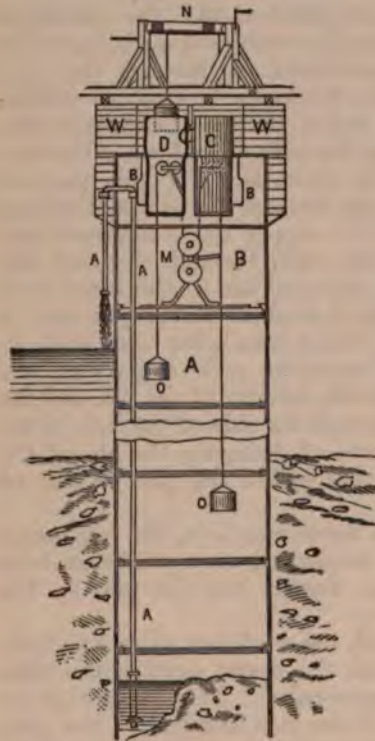

Fig. 56.—Longitudinal section of pile A, bell or working-chamber B, and air-locks C, D, used at the bridge at Szegedin, over the river Theiss, Hungary.

A, water discharge-pipe.  
B, equilibrium tubes of air-lock.  
C, elevation of air-lock.  
D, longitudinal section of air-lock.  
M, hoisting-gear in the bell.  
N, hoisting-gear for air-lock.  
W, counterpoise to compressed air.

The arrangements in this case (fig. 56) consist of a working chamber, B, termed the *bell*, which is a large air-tight iron cylindrical vessel fastened to the head of the pile, in which there is sufficient room for a hoisting apparatus, M, and several workmen, to raise the excavated soil to the level of the air-locks; of two small air-locks, D and C, which are inserted into the bell about two-thirds of their length; of a syphon-shaped water discharge-pipe A; and of a windlass N to raise the excavated soil out of the locks.

Each lock has a man-hole, with an undervalue on top, for

entering the lock, and a vertical door on the side for entering the bell. Each is provided with two sets of equilibrium valves, so arranged that they can be opened by a person from within the bell or the lock, to establish an equilibrium between the air in them; or from the outside of the lock, or the inside, to establish an equilibrium between the external air and that of the lock.

The air in the pile is condensed by air-pumps in the usual way.

The hoisting-engine in the bell has its gearing so arranged that the filled buckets can be delivered alternately into the locks, and from there be taken by the gearing of the windlass above. In the example represented by Fig. 56, a weight, *W*, formed of cast-iron bars, resting on brackets cast on the outside of the bell, forms a counter-pressure to the interior condensed air.

The pile is sunk by opening a condensed air-pipe leading to the external air, the lower portions of water discharge-pipe having been removed, and, with the tools used in excavating, placed within the bell.

The descent of the pile at each discharge of the condensed air depends upon the nature of the strata met with. In very compact clay the descent will, in some instances, be only a few inches in several discharges; while in sandy or gravelly strata it will descend as much, at times, as twelve or more feet. This is owing to the difference between the effect of the scour, and the resistance offered by the friction on the exterior surface of the pile. The resistances in sand and gravel being much less than in stiff clay. It has been found, in some cases, that two or three feet of a compact clay soil left within the piles at the bottom would prevent the scour and the further descent of the pile when the condensed air was discharged.

The piles are placed in position by a suitable hoisting-gearing raised upon a strong scaffolding; and in their descent are kept in a vertical position by guides placed in connection with the scaffolding. Great precautions have to be taken in managing the descent of the pile, when it is approaching the depth to which it is wished to sink it, so as to keep the top surface of each on the same level.

In the first applications of pneumatic piles, cast-iron cylinders of small diameters were used; as many being sunk as the resistance of the substratum upon which they rested required to support the base of the superstructure. Subsequently the diameters of the cylinders were enlarged, to



enable the soil to be excavated from the interior, and be replaced with hydraulic concrete. In some instances the concrete simply rested upon the bottom of the excavation. In others, wooden piles were driven within the cylinder some distance below its lower end, and the concrete thrown in to rest upon the heads of the piles.

*Harlem Bridge.*—In the Harlem Bridge the piles were six feet in diameter, and cast in lengths of ten feet. The air-lock was of the same diameter as the piles, and six feet high; the valves or man-holes twenty inches in diameter. The most noticeable feature in this part of the structure, is the expedient of using an underpinning of plank and concrete, to obtain a wider spread of the foundation bed, and a greater bearing surface for the superstructure to rest on. For this purpose, plank five feet long, three inches wide, and one inch and a quarter thick (Fig. 55) were forced under the bottom of the pile, in sections of three feet wide on opposite sides, and in an inclined direction, so as to gain an additional spread of foundation base of two feet around and beyond the pile. These formed a temporary roofing, from beneath which the soil was rapidly removed, and the excavated space filled in with concrete. Finding great inconvenience in this process, from the rapidity with which the water and sand came in on the sides, an additional condensation was given to the compressed air of six to ten feet extra water pressure; this was found to counteract the external pressure, so as to allow the excavations to be carried on with facility.

The refuse gas-pipes which were used to convey the compressed air down between the bottom of the concrete and the underlying soil, as well as giving it a passage between the outside of the pipes and the body of the concrete, were distributed through the concrete about a foot apart.

The bottom of the foundation in this example was thirty feet below the surface of the river-bed, and fifty below tide.

An opinion has obtained, from the condition in which the hydraulic concrete was found in a pile accidentally fractured, in which it had lain for some time, that this material did not harden when subjected to the great pressure of the water from the bottom. A remedy, it is stated, has been found for this by using a portion of fragments of a porous brick in a dry state instead of stone, in the composition of the concrete, as was done in the case of the piers of the bridge at Szegedin, in Hungary; and by inserting in the body of the concrete half-inch gas-pipes, through which the compressed

air was diffused throughout the mass, as practised at the Harlem Bridge by Mr. McAlpine.

**Bridge over the Theiss.**—The soil below the bed of the river Theiss, at Szegedin, is alluvial, and found in alternate strata of compact clay and sand to an indefinite depth. The current throughout its course is sluggish, having a surface velocity at Szegedin, during the highest stage of the waters, of from three to three and a half feet. The rise and fall of the water are both very gradual; the highest stage being about twenty-six feet, and the mean level about sixteen feet. The arched ribs and other superstructure of the bridge were of wrought-iron plates. Each pier was formed of two piles, or columns, filled with *béton*, as above described; and each supporting one track of the railroad. They were cast in lengths of six feet, and ten feet in diameter, and one inch and one-tenth in thickness. The piles were sunk to the depth of about thirty feet below the surface of the bed; and about forty feet below the ordinary low-water level. Their height corresponded to the highest water level, or nearly thirty-three feet above the presumed scour of the bed.

The interior excavation of the soil was carried down to the first joint, or six feet from the bottom of the column. To compress the soil below the column to sustain better the superincumbent weight, twelve piles of pine were driven within the column to a depth of twenty feet below the bottom.

The air-locks were each about six feet six inches in height, and two feet nine inches in diameter.

To provide against the scour of the current, the entire pier was enclosed by a row of square sheeting-piles, driven to the level of the bottom of the columns, and about two feet from them. The space between these piles and columns, to the depth of ten feet below the bed level, was filled with hydraulic concrete; and the piles were surrounded by loose stone with a spread of about ten feet from the piles.

As large quantities of hydraulic concrete are required for filling the piles, the method pursued in Germany, and as practised at the bridge at Szegedin, for mixing the mortar and fragments of brick or stone, commends itself for its economy, and the thoroughness with which the materials are incorporated. A wooden cylinder about twelve feet long, and four feet diameter, made and hooped like a barrel, and lined with sheet-iron, placed in an inclined position of  $\frac{1}{8}$  to the horizon, was made to revolve by a band set in motion by a steam-engine, from fifteen to twenty revolutions in a minute. The cylinder was fed by a hopper at the upper end, into which

the materials were thrown, and they were discharged thoroughly mixed and ready for use into wheelbarrows at the lower end. It is stated that this simple machine delivered from 280 to 350 cubic feet in ten hours.

The concrete is usually thrown down into the pile from the bell or lock. At the bridge at Szegedin the double locks were, alternately, nearly filled with the concrete, and it was raked out from them and thrown into the pile; care being taken to work it in well by hand, around the flanges and joints.

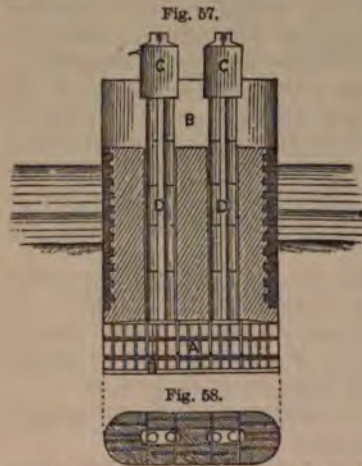

Fig. 57.—Longitudinal section of the caisson and masonry of a pier of a railroad bridge over the Scarff, at L'Orient, France.

Fig. 58.—Plan.

- A, working-chamber for excavating soil.
- B, interior elevation of caisson.
- C, C, elevation of the bells containing the double air-locks.
- D, D, cylinders for communication between bells and working-chamber.

Bridge over the Savannah River on the line of the Charleston and Savannah Rail Road. The air-locks on these piles were similar to the Harlem plan. Light was admitted into the air-lock by means of large bulls-eye glasses, and thence into the body of the pile in the same way, but this mode was found to be worthless, on account of the mud in the bottom of the air-lock which covered the glass. The engineer employed a secondary small air lock so that the material which was brought into the main one could be discharged at any time, and thus the work go on with less interruption, and the bulls-eyes became more serviceable. With the secondary air-lock the work progressed more rapidly; the ratio for a given amount of work being

$$\frac{\text{Time by old air-lock}}{\text{Time by new air-lock}} = \frac{14}{5}$$

By a fortunate discovery the engineer discovered that the pressure of the air in the pile was sufficient to force sand from

the bottom of the pile through a vertical pipe to a height above the surface of the water outside the works. A sort of telescopic tube was attached to the lower end of a pipe so that it could be easily moved downward as the excavation progressed. This greatly facilitated the progress of the work, for it was found that to do a given amount of work the ratio was

$$\frac{\text{Time by old air-lock} \dots}{\text{Time by blowing out sand}} = \frac{14}{\frac{1}{3}} = 28$$

This mode of excavation has been adopted to some extent in the caissons of the East River Bridge. This process also secures thorough ventilation. The same plan has also been used in the Omaha Bridge and Leavenworth Bridge with equally good results.

It is sometimes very difficult to keep the tubes vertical. When they begin to incline efforts should be made immediately to bring them to an erect position. In some cases wedges or blocks placed under the lower side and suddenly relieving the pressure will correct the evil. An ingenious mode was adopted by the engineer of the Omaha Bridge. He bored several holes through the tubes on the upper side, through which the compressed air escaped and thus disturbed the soil and relieved the pressure on that side so that it would sink faster. Strong levers have been used to pull on the top whilst the tube was sinking, but not with very marked results. In at least one very obstinate case, in which the holes on the upper side, combined with the action of a strong lever, did not alone effect the desired result, a ram was used in combination with the other devices and the erect position was quickly secured. The jar produced by the ram whilst the tube was sinking seemed to give great effect to the other devices.

Gen. W. S. Smith, who had charge of the construction of the foundations of the Omaha and Leavenworth Bridges, is of opinion that a pneumatic caisson, surmounted by masonry, is cheaper and better than pneumatic pile piers, but it is evident that circumstances may often determine which is preferable in any particular case.

**459. Pneumatic Caissons.** The application of compressed air for laying foundations has been further extended in some of the railroad bridges recently constructed in Europe; by using wrought-iron caissons of sufficient dimensions to serve as an envelope, or jacket, for the masonry of an entire pier; and gradually sinking the whole to the requisite depth, by excavating the soil within the pier to the desired level.

The caissons (Figs. 57, 58) for this purpose were divided into two compartments.

The lower A (Fig. 57), which served as a chamber for the workmen, for excavating the soil, was strongly roofed at top, with iron bars and iron sheeting, to bear the weight of the masonry that rested upon it; and was securely buttressed on the sides to resist the inward pressure of the soil on the outside. The upper chamber, B, served as an ordinary caisson, fitting closely to the masonry on the sides, and rising sufficiently above it to exclude the water during the construction of the masonry: the body of which, composed of béton with a facing of stone, was gradually raised as the caisson was sunk through the earth overlying a bed of rock upon which the pier was finally to rest.

The working chamber A was connected with two bells C, C, by two vertical iron cylinders D, D (Fig. 57), for each bell; these cylinders serving as a communication between the working-chamber and bells, for the passage of the workmen from one to the other, for raising the excavated soil, and as a passage for the compressed air forced in by the air-pumps.

Each bell contained two air-locks for communicating between it and the exterior; and a hoisting-gearing for the excavated soil; the filled buckets ascending through one cylinder, and the empty ones descending through the other.

The lower chamber, the bottom of which was open, was kept filled with compressed air of sufficient density to exclude the water, and enable the workmen to excavate the soil.

The caisson was gradually sunk, by the weight of the superincumbent mass, as the soil below was removed.

So soon as the rock-bed was reached, the surface was thoroughly cleaned off, and levelled under the edges of the bottom of the caisson, and the chamber A was gradually filled in with masonry closely up to its roof. Finally the cylinders D were removed, and the wells occupied by them in the body of the pier, filled with béton.

As a matter of interest, on the subject of laying foundations by means of pneumatic piles and caissons, a few additional facts in connection with the examples above cited will not be out of place here.

**Bridge over the Scorff.** In the example of the bridge at L'Orient over the Scorff, the river-bed is a stratum of mud, forty-six feet in depth, resting upon a surface of hard schistoze rock more or less inclined and uneven. The level of mean tide is about sixty feet above the rock surface; that of the highest tide seventy feet.

The caissons used in this example were designed for the piers of a stone bridge, and were about forty feet long and twelve feet broad. The bells, or upper working chambers, were ten feet high and eight feet in diameter; the lower working-chamber ten feet high; and the cylinders, for communication between them, two feet and a half in diameter.

The caissons were built of sheet-iron, in zones increasing in thickness from the top to the bottom; but not having been buttressed within against the pressure of the water, as the lower working-chamber was, they yielded and got out of shape.

In a subsequent structure of nearly the same dimensions, for a railroad bridge at Nantes, the same failure took place, and precautions were then taken against it by the insertion of cross-stays, which were removed as the masonry was carried up. In the caissons used in this case, the bells and air-locks were made larger. Each air-lock had three separate compartments; one for the passage of the workmen which could contain four men; one for the barrows by which the excavated soil was removed, and one for the concrete to fill up the lower working chamber, when the excavation was completed.

**St. Louis Bridge.** The caissons for the two piers of this bridge differ in no material respect, so that a description of one will equally apply to the other. The air-chambers are nine feet high, the sides being formed of  $\frac{3}{4}$ -inch plate iron in the larger, and  $\frac{1}{2}$ -inch in the smaller. The air-chamber is simply a huge diving-bell of the full size of the pier. The iron plates K, K (Fig. 59), forming its roof, are of  $\frac{1}{2}$ -inch thickness. Transversely over this and riveted firmly to it are thirteen iron girders L, at intervals of five and a half feet. Beneath the roof two massive timber girders C, C (Figs. 59 and 60), in an opposite direction to the iron ones, divide the air-chamber into three nearly equal parts. Communication between the three divisions is had through openings made for this purpose in the girders. These timber girders are intended to rest on the sand and support the roof from below. The sides of the air-chambers are strongly braced with plate iron brackets O O, stiffened with angle iron. Between the brackets is placed all around the chamber a course of strong timbers, the bottom of which is level with that of the girders, intended to rest on the sand and assist in supporting the weight. The support given by the timbers, together with the buoyant power of the compressed air in the chamber and the friction of the sand on the sides, is the only means relied on to sustain the pier in its gradual descent to the rock.

Fig. 59.

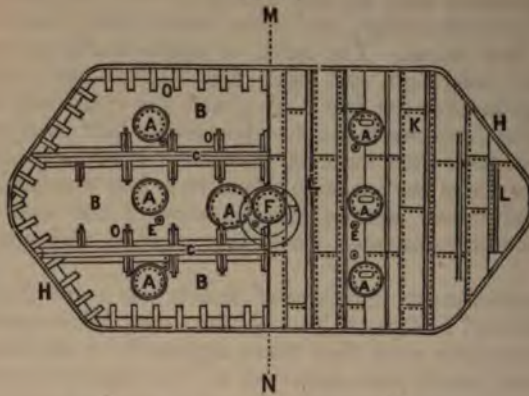

Fig. 60.

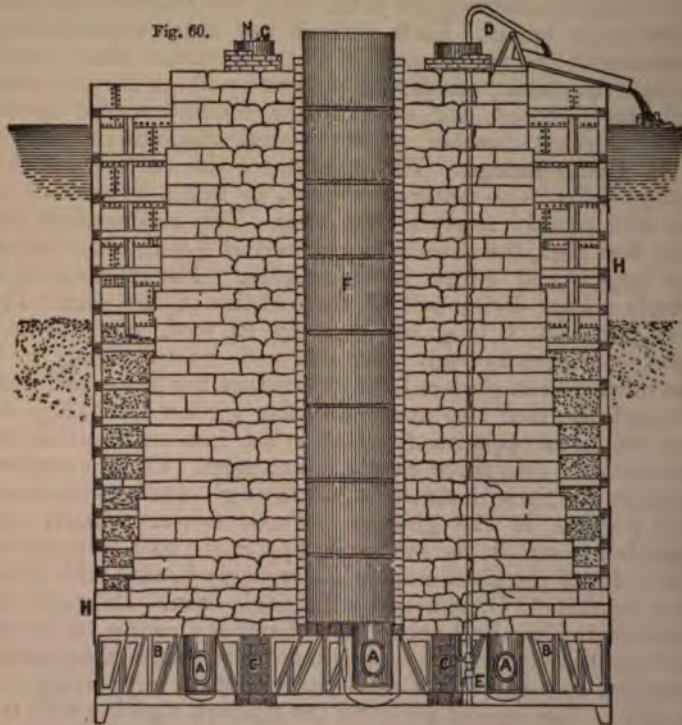

Fig. 59—Represents the plan of the caisson of the East pier of the Illinois and St. Louis Bridge. Fig. 60 represents transverse section of the same. A, air-locks. B, air-chamber. C, timber girders. D, discharge of sand. E, sand-pumps. F, main entrance shaft. G, side shafts. H, iron sides. I, bracing for H. K, iron deck or roof. L, iron girders. O, strengthening girders

The air-locks A A, heretofore as a rule placed above the surface of the water, are located within the roof of the air-chamber, and access is had to them through brick wells F, G, thus avoiding the inconvenience and delay of adding new joints under the locks.

The sand-pumps E are placed on the roof of the chamber, their suction pipes extending through the chamber to the sand. The action of these pumps is very simple. A stream of water is forced down the pipe B, (Fig. 61), and discharged near the sand into the pipe A, through the annular jet C. The jet creates a vacuum below it, by which the sand is drawn into the second pipe, the lower end of which is in the sand, and the force of the jet carries it up to the mouth of the pump so soon as it passes C.

The abutments at the east end of the bridge (Figs. 61 a and 61 b) differed in some of the details of their construction from the piers.

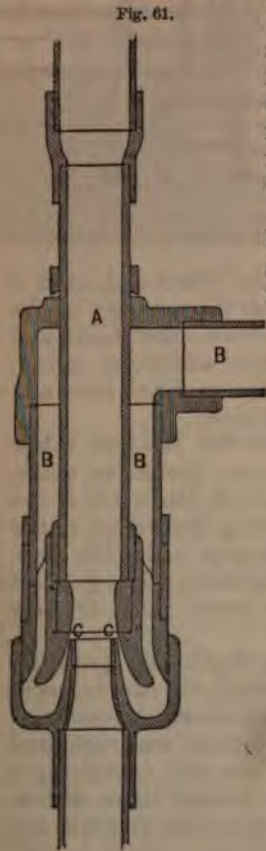

Fig. 61, represents a vertical section of a sand-pump.  
A, pump barrel.  
B, injection pipe.  
C, annular jet.

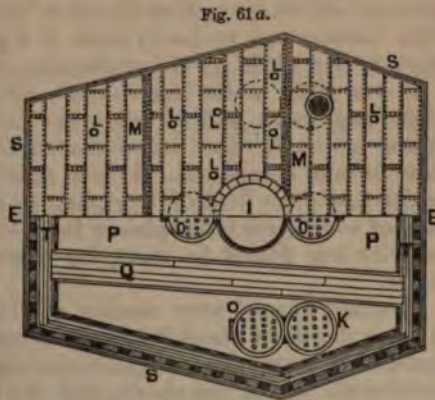
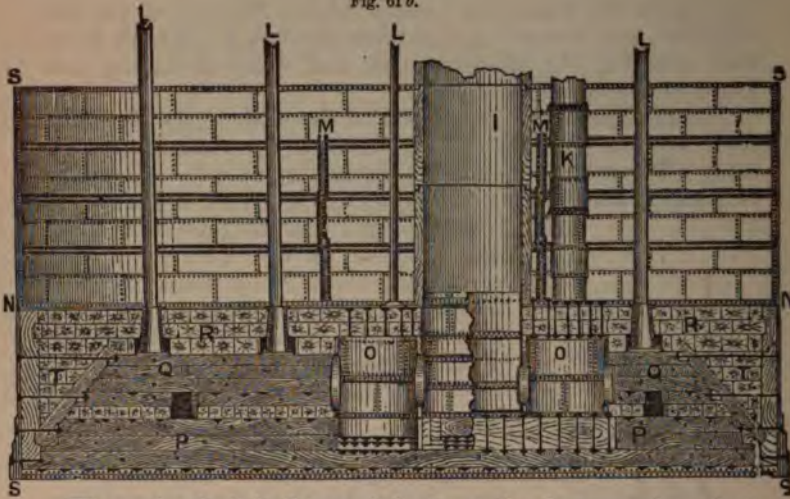

Fig. 61 a, is a part plan and part section of the east abutment of the St. Louis Bridge. Fig. 61 b, is a vertical section of the same.

- I, is the main shaft.
- KK, the side shafts.
- MM, iron girders.
- OO, the air-locks.
- PP, the air-chamber.
- QQ, the timber girders.
- RR, the timber deck.
- SS, the iron sheeting.
- TT, the timber sides of the caisson.



Fig. 61 b.



The main shaft had two air-locks at the lower end, each 8 feet in diameter, having about four times the capacity of the one used in the piers. There were also two other shafts and air-locks which were introduced to secure additional safety. This caisson was probably sunk to a greater depth than any other in the world by the pneumatic process.

It was sunk to the native rock, which was 136 feet below high-water mark, and 94 below the extreme low-water mark. It was about 110 feet below the surface of the water at the time it was completed. It was extremely hazardous to the health and even lives of workmen to be kept under the pressure of over three atmospheres for a long time. The greatest security was found in changing them every three or four hours.

Candles burned very readily at this depth and pressure. After a depth of about 80 feet was reached, the candles were inclosed in a strong glass globe, the inside of which communicated with one of the shafts, and the pressure was regulated by a small tube passing through the globe and containing a check valve. In this way the candles burned in an atmosphere whose pressure was about the same as the external air. (See *London Engineering*, 1870 and 1871.)

**East River Bridge.** The caisson for this bridge is composed almost wholly of wood. The air-chamber (Fig. 62) is nine feet six inches high, the roof being made of fifteen courses of timbers, one foot thick, the lower five (A) being

laid solid, the upper ten (C) crossing in alternate layers, and placed about a foot apart, the spaces between the timbers being filled with concrete. The sides (B) of the air-chamber are V shape, made very solid, nine feet thick at top, and eight inches at the bottom, which is heavily shod with iron. Between

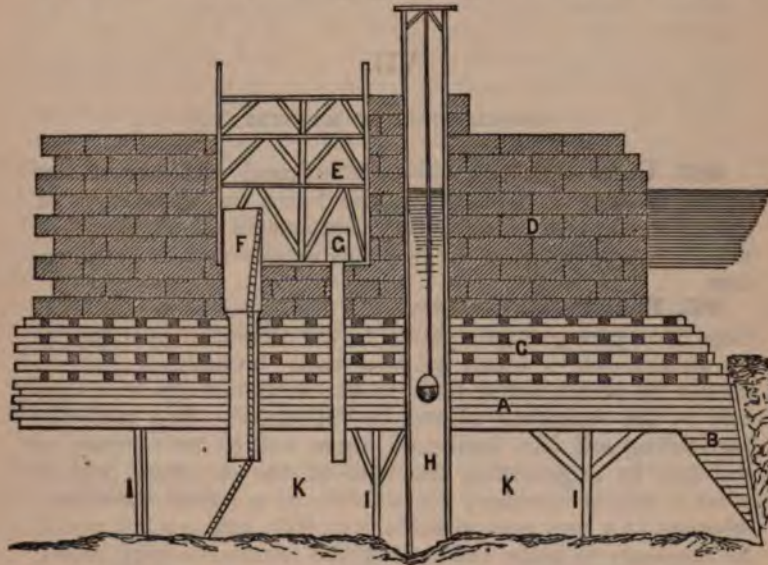

Fig. 62 represents a vertical section of the Brooklyn Caisson of the East River Bridge.

- A, lower timber courses of roof, laid solid.
- B, timber sides of air-chamber.
- C, upper timber courses of roof, laid crosswise, and spaces filled in with concrete.
- D, masonry of pier.
- E, dam to prevent water from reaching shafts.
- F, air-shaft and lock.
- G, supply shaft.
- H, excavation shaft.
- I, heavy timber partitions.
- K, air-chamber.

the fourth and fifth courses of the roof is laid a sheet of tin, which is continued down underneath the outside sheathing. The air-chamber is divided into six compartments by heavy timber girders. The shafts through which the heavy material is raised extend below the level of the excavation at the bottom, and are constantly open; but the compressed air is prevented from escaping by a column of water, which is maintained at nearly the same height as the water in the river by the pressure of the compressed air. If the pressure of the air should be made to greatly exceed that at which it is ordinarily maintained, it would blow all the water out of the shaft

and the air would entirely escape, but every necessary precaution was used to keep a proper pressure of the air. An accident of this kind once took place in the Brooklyn caisson.

## VII.

### CONSTRUCTION OF MASONRY.

460. Under this head will be comprised whatever relates to the manner of determining the forms and dimensions of the most important elementary components of structures of masonry, together with the practical details of their construction.

461. **Foundation Courses.** As the object of the foundations is to give greater stability to the structure by diffusing its weight over a broad surface, their breadth, or *spread*, should be proportioned both to the weight of the structure and to the resistance offered by the subsoil. In a perfectly unyielding soil, like hard rock, there will be no increase of stability by augmenting the base of the structure beyond what is strictly necessary for stability in a lateral direction; whereas in a very compressible soil, like soft mud, it would be necessary to make the base of the foundation very broad, so that by diffusing the weight over a great surface, the subsoil may offer sufficient resistance, and any unequal settling be obviated.

462. The thickness of the foundation course will depend on the spread; the base is made broader than the top for motives of economy. This diminution of the volume (Fig. 63)

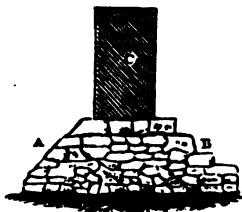

Fig. 63.—Section of foundation courses and superstructure.  
A, batter.  
B, offsets.  
C, superstructure.

is made either in steps, termed *offsets*, or else by giving a uniform batter from the base to the top.

When the foundation has to resist only a vertical pressure,

an equal batter is given to it on each side; but if it has to resist also a lateral effort, the spread should be greater on the side opposed to this effort, in order to resist its tendency, which would be to cause a yielding on that side.

463. The bottom course of the foundations is usually formed of the largest sized blocks, roughly dressed off with the hammer; but if the bed is compressible, or the surfaces of the blocks are winding, it is preferable to use blocks of a small size for the bottom course; because these small blocks can be firmly settled, by means of a heavy beetle, into close contact with the bed, which cannot be done with large-sized blocks, particularly if their under surface is not perfectly plane. The next course above the bottom one should be of large blocks, to bind in a firm manner the smaller blocks of the bottom course, and to diffuse the weight more uniformly over them.

464. When a foundation for a structure rests on isolated supports, like the pillars, or columns of an edifice, an *inverted* or *counter-arch*, (Fig. 64,) should connect the top course of the foundation under the base of each isolated support, so that the pressure on any two adjacent ones may be distributed over the bed of the foundation in the interval between them. This precaution is obviously necessary in compressible soils.



Fig. 64.—Section of vertical supports on reversed arches

- A, reversed arch.
- B, vertical supports.
- C, bed of stone.

The reversed arch is also used to give greater breadth to the foundations of a wall with counterforts, and in cases where an upward pressure from water, or a semi-fluid soil requires to be counteracted. In the former case the reversed arches are turned under the counterforts; in the latter they form the points of support of the walls of the structure.

465. The angles of the foundations should be formed of the most massive blocks. The courses should be carried up uniformly throughout the foundation, to prevent unequal settling in the mass.

The stones of the top course of the foundation should be

sufficiently large to allow the course of the superstructure next above to rest on the exterior stones of the top course.

466. Hydraulic mortar should be used for the foundations, and the upper courses of the structure should not be commenced until the mortar has partially set throughout the entire foundation.

**467. Component parts of Structures of Masonry.** These may be divided into several classes, according to the efforts they sustain; their forms and dimensions depending on these efforts.

1st. Those which sustain only their own weight, and are not liable to any cross strain upon the blocks of which they are formed, as the walls of enclosures.

2d. Those which, besides their own weight, sustain a vertical pressure arising from a weight borne by them, as the walls of edifices, columns, the piers of arches, &c.

3d. Those which sustain lateral pressures, and cross strains upon the blocks, arising from the action of the earth, water, frames or arches.

4th. Those which sustain a vertical upward, or downward pressure, and a cross strain, as areas, lintels, &c.

5th. Those which transfer the pressure they directly receive to lateral points of supports, as arches.

**468. Walls of Enclosure.** Walls for these purposes may be built of brick, rubble, or dry stone.

Brick walls are usually built vertically upon the two faces; and their thickness cannot be less than that of one brick.

Rubble stone walls should never receive a thickness less than 18 inches when the two faces are vertical. Rondelet, in his work *l'Art de Bâtir*, lays down a rule that the mean thickness of both rubble and brick walls should be  $\frac{1}{8}$  of their height; but rubble stone walls are rarely made so thin as this.

Dry stone walls should not receive a less thickness than two feet. When their height exceeds 12 feet, their mean thickness should not be less than  $\frac{1}{3}$  of the height.

Stone walls are usually built with sloping faces. The batter should not be greater, when the stones are cemented with mortar, than one base to six perpendicular, in order that the rain may run rapidly from the surface, and that the wall be not too much exposed to decay from the germination of seeds which may lodge in the joints.

The batter is arranged either by building the wall in offsets from top to bottom, or by a uniform surface. In either case, the thickness of the wall at top should not be less than from 8 to 12 inches.

When a wall is built with an equal batter on each face, and the thickness at the top and the mean thickness are fixed, *the base of the wall*, or its thickness at the bottom, *will be found by subtracting the thickness at top from twice the mean thickness*. This rule evidently makes the batter of the wall depend upon the two preceding dimensions.

The mean thickness of long walls may be advantageously diminished by placing counterforts, or buttresses, upon each face at equal distances along the line of the wall. These are spurs of masonry projecting some length from the wall, and are firmly connected with it by a suitable bond. The horizontal section of the counterforts may be rectangular; their height should be the same as that of the wall.

**469. Vertical Supports.** These consist of walls, columns, or pillars, according to circumstances. The dimensions of the courses of masonry which compose the supports should be regulated by the weight borne. If, as in the walls of edifices, the resultant of the efforts sustained by the wall should not be vertical, it must not intersect the base of the wall so near the outer edge, that the stone forming the lowest course would be in danger of being crushed.

Cross walls between the exterior walls, as the partition walls of edifices, should be regarded as counterforts which strengthen the main walls.

**470. Areas.** The term *area* is applied to a mass of masonry, usually of a uniform thickness, laid over the ground enclosed by the foundations of walls. It seldom happens that areas have an upward pressure to sustain. Whenever this occurs, as in the case of the bottoms of cellars in communication with a head of water which causes an upward pressure, the thickness and arrangement of the area should be regulated to resist this pressure. When the pressure is considerable, an area of uniform thickness may not be sufficiently strong to ensure safety; in this case an *inverted arch* must be used. The foundation of the Capitol building at Albany, N. Y., rests on an immense *area*, which is formed of successive layers of broken stone and concrete, making an *area* of several feet in thickness. The first stones of the piers are very large and flat and nearly cover the whole *area* so that there is little or no danger of an upward pressure.

**471. Retaining or Sustaining Walls.** These terms are applied to walls which sustain a lateral pressure from an embankment, or a head of water.

**472.** Retaining walls may yield by sliding either along the base of the foundation courses, or along one of the horizontal

joints, or by rotation about the exterior edge of some one of the horizontal joints, or the line of fracture may be oblique to the base.

478. The determination of the form and dimensions of a retaining wall for an embankment of earth is a problem of considerable intricacy, and the mathematical solutions which have been given of it have generally been confined to particular cases, for which approximate results alone have been obtained; these, however, present sufficient accuracy for all practical purposes within the limits to which the solutions are applicable. Among the many solutions of this problem, those given by M. Poncelet, of the Corps of French Military Engineers, in a Memoir on this subject, published in the *Mémoires de l'Officier du Génie*, No. 10, present a degree of research and completeness which peculiarly characterize all the writings of this gentleman, and have given to his productions a claim to the fullest confidence of practical men.

The following formula, applicable to cases of rotation about the exterior edge of the lowest horizontal joint, are taken from the memoir above cited.

Calling  $H$ , the height  $BC$  (Fig. 65) of a wall of uniform thickness, the face and back being vertical.

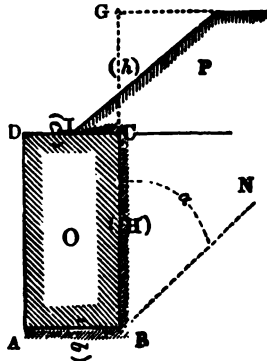

Fig. 65.—Represents a section O of a retaining wall with the face and back vertical.  
P, section of the embankment above the wall.

$h$ , the mean height  $CG$  of the embankment, retained by the wall, above the top of the wall.

$c$ , the *berm*  $DI$ , or distance between the foot of the embankment and the outer edge of the top of the wall.

$a$ , the angle between the line of the natural slope  $BN$  of the earth of the embankment and the vertical  $BG$ .

$f = \cot. a$ , the co-efficient of friction of the earth of the embankment.

$w$ , the weight of a cubic foot of the earth.

$w'$ , the weight of a cubic foot of the masonry of the wall.  
 $b$ , the base  $AB$ , or thickness of the wall at bottom.

Then,

$$b = 0.74 \tan. \frac{1}{2} a \sqrt{\frac{w}{w'}} (h + 1.126H) + 0.0488h - 0.56c \tan. a \left( \frac{h}{H} - 0.6 \frac{w}{w'} \right) \left( \frac{h}{H} - 0.25 \right).$$

The above formula gives the value of the base of a wall with vertical faces, within a near degree of approximation to the true result, only when the values of the quantities which enter into it are confined within certain limits. These limits are as follows: for  $h$ , between 0 and  $H$ ;  $c$ , between 0 and  $\frac{1}{2}H$ ;  $f$ , between 0.6 and 1.4, which correspond to values of  $a$  of  $70^\circ$  and  $35^\circ$ , being in the one case the angle which the line of the natural slope of very fine dry sand assumes, and in the other of heavy clayey earth; and for  $w$ , between  $w'$ , and  $\frac{3}{4}w'$ . Besides these limits, the formula also rests on the assumption that the moment of the pressure against the wall is 1.912 times the moment of strict equilibrium between it and the wall. This excess of stability given to the wall supposes an excess of resistance above the pressure against it equal to what obtains in the retaining walls of Vauban, for fortifications which have now stood the test of more than a century with security.

474. Having by the preceding formula calculated the value of  $b$  for a vertical wall, the base  $b'$  of another wall, presenting equal stability, but having a batter on the face, the back being vertical, which is the usual form of the cross sec-

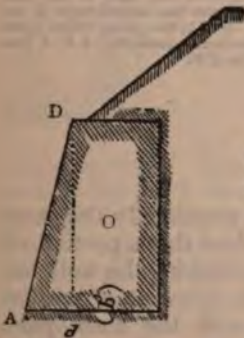

Fig. 66—Represents a section O of a retaining wall with a sloping face AD.  
 P, section of the embankment.

tion of retaining walls, can be calculated from the following notation and formula.

Calling (Fig. 66)  $b'$  the base of the sloping wall.



$n = \frac{Ad}{Dd}$  the batter, or ratio of the base of the slope to the perpendicular, or height of the wall.

Then,

$$b' = b + \frac{1}{10}nH.$$

475. With regard to sliding either on the base of the foundation courses, or on the bed of any of the horizontal joints of the wall, M. Poncelet shows, in the memoir cited, by a comparison of the results obtained from calculations made under the suppositions both of rotation and sliding, that no danger need be apprehended from the latter, when the dimensions are calculated to conform to the former, so long as the limits of  $h$  are taken between 0 and  $4H$ ; particularly if the precaution be taken to allow the mortar of the masonry to set firmly before forming the embankment behind the wall.

476. Mr. C. S. Constable read a paper before the American Society of Civil Engineers in New York, in 1873, in which he showed by means of a model and experiments that the prism which produces the maximum thrust or pressure was less than GCD. The wall, when composed of blocks, will not turn over bodily about the outer edge, but there will be a broken line of fracture as shown by the heavy line in (Fig. 67), the general direction of which corresponds to the natural slope

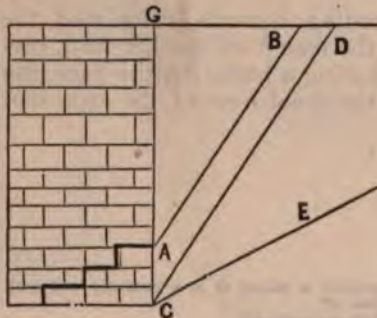

Fig. 67—C G is the back of the wall. C E represents the natural slope of the earth. G C D the prism which gives the maximum pressure. A B a line parallel to C D.

of the earth, although the two have not necessarily the same direction. This being the case, it is evident that a portion of the prism GCD will not be active in overturning the wall, but on the other hand will prevent, or tend to prevent, a portion of the back of the wall from moving with the main part. As a result of this investigation it is evident that the formulas which are founded on the supposition that the whole of the prism GCD is active in producing a rotation of the wall

err on the safe side, and give an unnecessarily large margin for safety.

His experiments also showed that the wall might start to fall but not fall, and that it required considerable jarring to cause it to fall. When the movement began the face did not remain plane but became curved. This shows why in practice walls have assumed a curved face, and yet stand securely for many years. After a slight movement has taken place, the pressure due to the earth is slightly relieved, and the whole mass takes up a new position of equilibrium, until finally the earth nearly supports itself.

**477. Form of Section of Retaining Walls.** The more usual form of cross section is that in which the back of the wall is built vertically, and the face with a batter varying between one base to six perpendicular, and one base to twenty-four perpendicular. The former limit having been adopted, for the reasons already assigned, to secure the joints from the effects of weather; and the latter because a wall having a face more nearly vertical is liable in time to yield to the effects of the pressure, and lean forward.

**478.** The most advantageous form of cross section for economy of masonry is the one (Fig. 68) termed a *leaning*

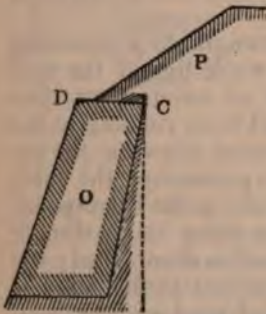

Fig. 68—Represents a section O of a leaning retaining wall with a sloping face AD and the back BC counter-sloped.

retaining wall. The counter slope, or reversed batter of the back of the wall, should not be less than six perpendicular to one base. In this case strength requires that the perpendicular let fall from the centre of gravity of the section upon the base, should fall so far within the inner edge of the base, that the stone of the bottom course of the foundation may present sufficient surface to bear the pressure upon it.

**479.** Walls with a curved batter (Fig. 69) both upon the face and back, have been used in England, by some engineers, for quays. They present no peculiar advantages in strength

over walls with plane faces and backs, and require particular care in arranging the bond, and fitting the stones or bricks of the face.

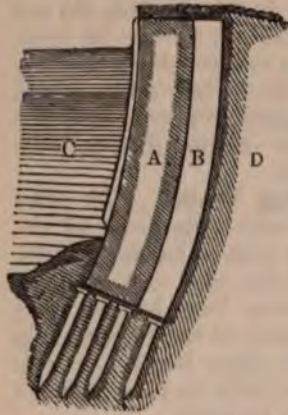

Fig. 69—Represents a section A of a wall with a curved face and back, and an elevation B of the counterforts.  
C, water.  
D, embankment behind the wall.  
a, fender beams of timber.

**480. Measures for increasing the Strength of Retaining Walls.** These consist in the addition of counterforts, in the use of relieving arches, and in the modes of forming the embankment.

**481.** Counterforts give additional strength to a retaining wall in several ways. By dividing the whole line of the wall into shorter lengths between each pair of counterforts, they prevent the horizontal courses of the wall from yielding to the pressure of the earth, and bulging outward between the extremities of the walls; by receiving the pressure of the earth on the back of the counterfort, instead of on the corresponding portion of the back of the wall, its effect in producing rotation about the exterior foot of the wall is diminished; the sides of the counterforts acting as abutments to the mass of earth between them may, in the case of sand, or like soil, cause the portion of the wall between the counterforts to be relieved from a part of the pressure of the earth behind it, owing to the manner in which the particles of sand become buttressed against each other when confined laterally, and offer a resistance to pressure.

**482.** The horizontal section of counterforts may be either rectangular or trapezoidal. When placed against the back of a wall, the rectangular form offers the greater stability in the case of rotation, and is more economical in construction; the trapezoidal form gives a broader and therefore a firmer con-

nection between the wall and counterfort than the rectangular, a point of some consideration where, from the character of the materials, the strength of this connection must mainly depend upon the strength of the mortar used for the masonry.

483. Counterforts have been chiefly used by military engineers for the retaining walls of fortifications, termed *revêtements*. In regulating their form and dimensions, the practice of Vauban has generally been followed, which is to make the horizontal section of the counterfort trapezoidal, making the height of the trapezoid  $ef$  (Fig. 70), which corresponds to the

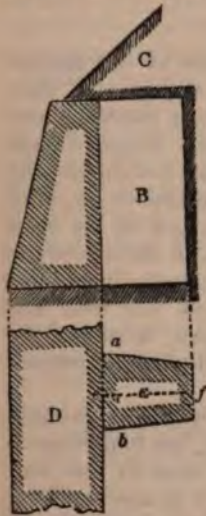

Fig. 70.—Represents a section A and plan D of a wall, and an elevation B, and plan E of a trapezoidal counterfort.

length of the counterfort, *two-tenths of the height of the wall added to two feet*, the base of the trapezoid  $ab$  corresponding to the junction of the counterfort and back of the wall, *one-tenth of the height added to two feet*, and the side  $cd$  which corresponds to the back of the counterfort equal to two-thirds of the base  $ab$ . The counterforts are placed from 15 to 18 feet from centre to centre along the back of the wall, according to the strength required.

484. In adding counterforts to walls, the practice has generally been to regard them only as giving additional stability to the wall, and not as a means of diminishing its volume of masonry of which the addition of the counterforts ought to admit.

485. *Relieving Arches* are so termed from their preventing a portion of the embankment from resting against the back

of the wall, and thus relieving it from a part of the pressure. They consist (Fig. 71) of one or more tiers of brick arches

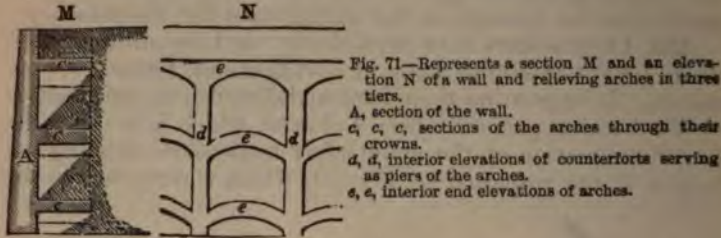

Fig. 71.—Represents a section M and an elevation N of a wall and relieving arches in three tiers.  
 A, section of the wall.  
 c, c, c, sections of the arches through their crowns.  
 d, d, interior elevations of counterforts serving as piers of the arches.  
 e, e, interior end elevations of arches.

built upon counterforts, which act as the piers of the arches.

In arranging a combination of relieving arches and their piers, the latter, like ordinary counterforts, are placed about 18 feet apart between their centre lines; their length should be so regulated that the earth behind them resting on the arches, and falling under them with the natural slope, shall not reach the wall between the arch and the foot of the back of the wall below the arch. The thickness of the arches, as well as that of the counterforts, will depend upon the weight which the arches sustain. The dimensions of the wall will be regulated by the decreased pressure against it caused by the action of the arches, and the point at which this pressure acts.

486. Whenever it becomes necessary to form the embankment before the mortar of the retaining wall has had time to set firmly, the portion of the embankment next to the wall may be of a compact binding earth placed in layers inclining downward from the back of the wall, and well rammed; or of a stiff mortar made either of clay, or sand, with about  $\frac{1}{10}$ th in bulk of lime. Instead of bringing the embankment directly against the back of the wall, dry stone, or fascines may be laid in to a suitable depth back from the wall for the same purpose. *The precaution, however, of allowing the mortar to set firmly before forming the embankment, should never be omitted except in cases of extreme urgency, and then the bond of the masonry should be arranged with peculiar care, to prevent disjunction along any of the horizontal joints.*

487. Walls built to sustain a pressure of water should be regulated in form and dimensions like the retaining walls of embankments. The buoyant effort of the water must be taken into account in determining the dimensions of the wall, whenever the masonry is so placed as to be partially immersed in the water.

488. Heavy walls, and even those of ordinary dimensions, when exposed to moisture, should be laid in hydraulic mortar. Grout has been tried in laying heavy rubble walls, but with decided want of success, the successive drenchings of the stone causing the sand to separate from the lime, leaving when dry a weak porous mortar. When the stone is laid in full mortar, grout may be used with advantage over each course, to fill any voids left in the mass.

489. Beton has frequently been used as a filling between the back and facing of water-tight walls; it presents no advantage over walls of cut, or rubble stone laid in hydraulic mortar, and causes unequal settling in the parts, unless great care is taken in the construction.

490. When a weight, arising from a mass of masonry or earth, rests upon two or more isolated supports, that portion of it which is distributed over the space, or *bearing* between any two of the supports, may be borne by a block of stone, termed a *lintel*, laid horizontally upon the supports, by a combination of blocks termed a *plate-bande*, so arranged as to resist, without disjunction, the pressure upon them; or by an arch.

491. **Lintel.** Owing to the slight resistance of stone to a cross strain, and to shocks, lintels of ordinary dimensions cannot be used alone with safety, for bearings over five or six feet. For wider bearings, a slight brick arch is thrown across the bearing above the lintel, and thus relieves it from the pressure of the parts above.

492. **Plate-bande.** The plate-bande is a combination of blocks cut in the form of truncated wedges. From the form of the blocks, the pressure thrown upon them causes a lateral pressure which must be sustained either by the supports, or by some other arrangement (Fig. 72).



Fig. 72—Represents a cross section of a plate-bande, showing the manner in which the voussoirs A, A and B are cut and connected by metal cramps, *ab*, tie of wrought iron for the plate-bande fastened to the bolts *cd*, let into the piers of the plate-bande.

The plate-bande should be used only for narrow bearings, as the upper edges of the blocks at the acute angles are liable to splinter from the pressure. If the bearing exceeds 10 feet, the plate-bande should be relieved from the pressure

by a brick arch above it. Additional means of strengthening the plate-bande are sometimes used by forming a broken joint between the blocks, or by a projection made on the face of one block to fit into a corresponding indent in the adjacent one, or by connecting the blocks with iron bolts.

When, from any cause, the supports cannot be made sufficiently strong to resist the lateral pressure of the plate-bande, the extreme blocks must be united by an iron bar, termed a *tie*, suitably arranged to keep the blocks from yielding.

493. **Arches.** The arch is a combination of wedge-shaped blocks, termed *arch stones*, or *voussoirs*, truncated towards the angle of the wedges by a curved surface which is usually normal to the surfaces of the joints between the blocks. This inferior surface of the arch is termed the *soffit*. The upper or outer surface of the arch is termed the *back* (Fig. 73).

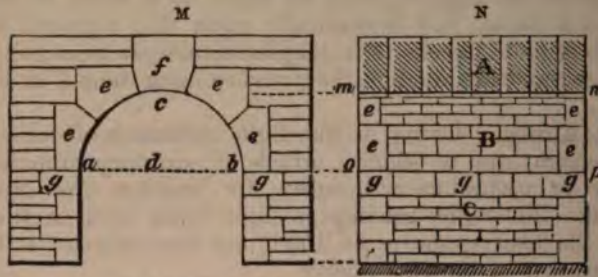

Fig. 73.—Represents an elevation M of the head of a right cylindrical arch, and a section N through the crown of the arch A, with an elevation B of the soffit and the face C of the abutment.

*ab*, span of the arch.  
*dc*, rise.  
*acb*, curve of the intrados.  
*e, e*, voussoirs forming ring courses of heads.  
*f*, key stone.  
*g*, cushion stone of abutment.  
*mn*, crown of the arch.  
*op*, springing line.

494. The extreme blocks of the arch rest against lateral supports, termed *abutments*, which sustain both the vertical pressure arising from the weight of the arch stones, and the weight of whatever lies upon them; also the lateral pressure caused by the action of the arch.

495. In a *range*, or series of arches placed side by side, the extreme supports are termed the abutments, the intermediate supports which sustain the intermediate arches and the halves of the two extreme ones are termed *piers*. When the size of the arches is the same, and their springing lines are

in the same horizontal plane, the piers receive no other pressure but that arising from the weight of the arches.

496. Arches are classified, from the form of the soffit, into *cylindrical*, *conical*, *conoidal*, *warped*, *annular*, *groined*, *cloistered*, and *domes*. They are also termed *right*, *oblique*, or *askew*, and *rampant*, from their direction with respect to a vertical, or horizontal plane.

497. Cylindrical, groined and cloistered arches are formed by the intersections of two or more cylindrical arches. The span of the arches may be different, but the rise is the same in each. The axes of the cylinders will be in the same plane, and they may intersect under any angle.

The groined arch (Fig. 74) is formed by removing those

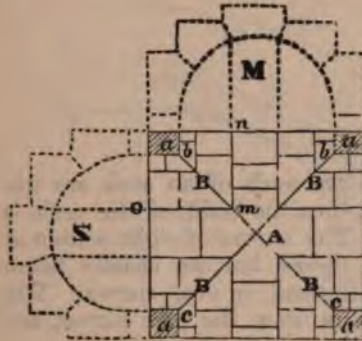

Fig. 74—Represents the plan of the soffit and the right sections M and N of the cylinders forming a groined arch.  
*aa*, pillars supporting the arch.  
*bc*, groins of the soffit.  
*om, mn*, edges of coursing joints.  
*A*, key-stone of the two arches formed of one block.  
*B, B*, groin stones of one block below the key-stone forming a part of each arch.

portions of each cylinder which lie under the other and between their common curves of intersection; thus forming a projecting, or salient edge on the soffit along these curves.

The cloistered arch (Fig. 75) is formed by removing those portions of each cylinder which are above the other and exterior to their common intersection, forming thus re-entering angles along the same lines.

498. The planes of the joints in both of these arches are placed in the same manner as in the simple cylindrical arch. The inner edges of the corresponding course of voussoirs in each arch are placed in the same plane parallel to that of the axes of the cylinders. The portions of the soffit in each cylinder, corresponding to each course of voussoirs, which form either the groin in the one case, or the re-entering angle in the other, are cut from a single stone, to present no joint along the common intersection of the arches, and to give them a firmer bond.



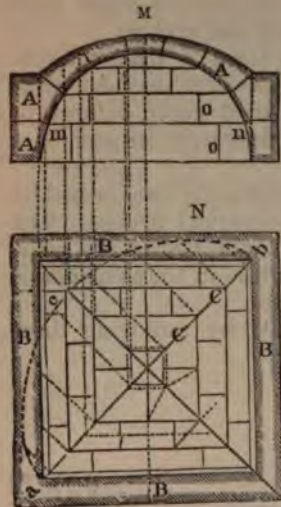

Fig. 75—Represents a section M of the voussoirs and an elevation of the soffit of a cloistered arch with a plan N of the soffit.

A, A, voussoirs.  
*m*, *m*, edge of coursing joint.  
*o*, *o*, edges of heading joints.  
 B, B, abutments of the arches.  
*acb*, curve of the groin.  
 C, C, groin stones of one block.

499. When the spans at the two ends of an arch are unequal, but the rise is the same, then the soffit of the arch is made of a conoidal surface. The curves of right section at the two ends may be of any figure, but are usually taken from some variety of the elliptical, or oval curves. The soffit is formed by moving a line upon the two curves, and parallel to the plane containing their spans

The conoidal arch belongs to the class with warped soffits. A variety of warped surfaces may be used for soffits according to circumstances; the joints and the bond depending on the generation of the surface.

500. In arranging the joints in conoidal arches, the heading joints are contained in planes perpendicular to the axis of the arch. The coursing joints are also formed of plane surfaces, so arranged that the portion of the joint corresponding to each block is formed by a plane normal to the conoid at the middle point of the lower edge of the block. In this way the joints of the string course will not be formed of continuous surfaces. To make them so, it would be necessary to give them the form of warped surfaces, which present more difficulty in their mechanical execution, and not sufficient advantages over the method just explained to compensate for having them continuous.

501. The annular arch is formed by revolving the plane of a semi-circle, or semi-oval, or other curve, about a line drawn

without the figure and parallel to the rise of the arch (Fig. 76). One series of joints in this arch will be formed by conical surfaces passing through the inner edges of the stones which correspond to the string courses; and the other series will be planes passed through the axis about which the semi-circle is revolved. This last series should break joints with each other.

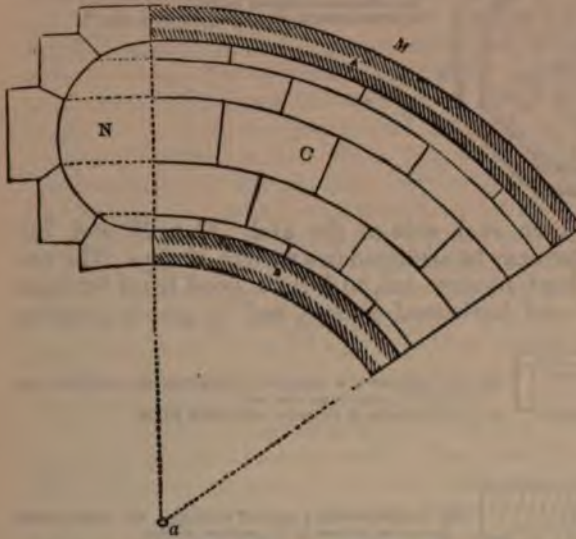

Fig. 76.—Represents a plan M of the abutments A and B, and the soffit C of an annular arch. N, right section of the arch. a, position of vertical axis around which the section N is revolved.

502. The soffit of a dome is usually formed by revolving the quadrant of one of the usual curves of cylindrical arches around the rise of the curve; or else by revolving the semi-curve about the line of the span, and taking the half of the surface thus generated for the soffit of the dome. In the first of these cases the horizontal section of the dome at the springing line will be a circle; in the second the entire curve of the semi-curve by which the soffit is generated. The plan of domes may also be of regular polygonal figures, in which case the soffit will be a polygonal-cloistered arch formed of equal sections of cylinders (Fig. 77). The joints and the bond are determined in the same manner as in other arches.

503. The voussoirs which form the ring course of the heads, in ordinary cylindrical arches, are usually terminated by plane surfaces at top and on the sides, for the purpose of connecting them with the horizontal courses of the head which

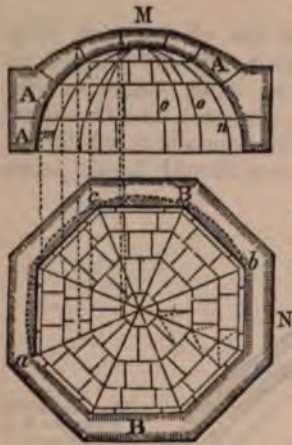

Fig. 77—Represents a section M of the voussoirs and an elevation of the soffit, with a plan N of the soffit of an octagonal-cloistered dome. The letters refer to the same parts as in Fig. 75.

lie above and on each side of the arch (Figs. 78 and 79). This connection may be arranged in a variety of ways. The two points to be kept in view are, to form a good bond between the voussoirs and horizontal courses, and to give a pleasing

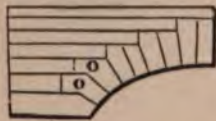

Fig. 78—Represents a manner of connecting the voussoirs and horizontal courses in an oval arch. o, o, are examples of voussoirs with elbow joints.



Fig. 79—Represents a mode of arranging the voussoirs and horizontal courses in flat segment arches.

architectural effect by the arrangement. This connection should always give a symmetrical appearance to the halves of the structure on each side of the crown. To effect these several objects it may be necessary, in cases of oval arches, to make the breadth of the voussoirs unequal, diminishing usually those near the springing lines.

504. In small arches the voussoirs near the springing line are so cut as to form a part also of the horizontal course (see Fig. 78), forming what is termed an *elbow joint*. This plan is objectionable, both because there is a waste of material in forming a joint of this kind, and the stone is liable to crack when the arch settles.

505. The forms and dimensions of the voussoirs should be determined both by geometrical drawings and numerical

calculation, whenever the arch is important, or presents any complication of form. The drawings should, in the first place, be made to a scale sufficiently large to determine the parts with accuracy, and from these, pattern drawings giving the parts in their true size may be made for the use of the mason. To make the pattern drawings, the side of a vertical wall, or a firm horizontal area may be prepared, with a thin coating of mortar, to receive a thin smooth coat of plaster of Paris. The drawing may be made on this surface in the usual manner, by describing the curve either by points from its calculated abscissas and ordinates, or, where it is formed of circular arcs, by using the ordinary instrument for describing such arcs when the centres fall within the limits of the prepared surface. In ovals the positions of the extreme radii should be accurately drawn either from calculation, or construction. To construct the intermediate normals, whenever the centres of the arcs do not fall on the surface, an arc with a chord of about one foot may be set off on each side of the point through which the normal is to be drawn, and the chord of the whole arc, thus set off, be bisected by a perpendicular. This construction will generally give a sufficiently accurate practical result for elliptical and other curves of a large size.

506. The masonry of arches may be of dressed stone, rubble, or brick.

In wide spans, particularly for oval and other flat arches, cut stone should alone be used. The joints should be dressed with extreme accuracy. As the voussoirs have to be supported by a framing of timber, termed a *centre*, until the arch is completed, and as this structure is liable to yield, both from the elasticity of the materials and the number of joints in the frame, an allowance for the settling in the arch, arising from these causes, is sometimes made, in cutting the joints of the voussoirs *false*, that is, not according to the true position of the normal, but from the supposed position the joints will take when the arch has settled thoroughly. The object of this is to bring the surfaces of the joints into perfect contact when the arch has assumed its permanent state of equilibrium, and thus prevent the voussoirs from breaking by unequal pressures on their coursing joints. This is a problem of considerable difficulty, and it will generally be better to cut the joints true, and guard against settling and its effects by giving great stiffness to the centres, and by placing between the joints of those voussoirs, where the principal movement takes place in arches, sheets of lead suitably hammered to fit the joint and yield to any pressure.

507. The manner of laying the voussoirs demands peculiar care, particularly in those which form the heads of the arch. The positions of the inner edges of the voussoirs are determined by fixed lines, marked on the abutments, or some other immovable object, and the calculated distances of the edges from these lines. These distances can be readily set off by means of the level and plumb-line. The angle of each joint can be fixed by a quadrant of a circle, connected with a plumb-line, on which the position of each joint is marked.

508. Brick may be used alone, or in combination with cut stone, for arches of considerable size. When the thickness of a brick arch exceeds a brick and a half, the bond from the soffit outward presents some difficulties. If the bricks are laid in concentric layers, or *shells*, a continuous joint will be formed parallel to the surface of the soffit, which will probably yield when the arch settles, causing the shells to separate (Fig. 80). If the bricks are laid like ordinary string courses,

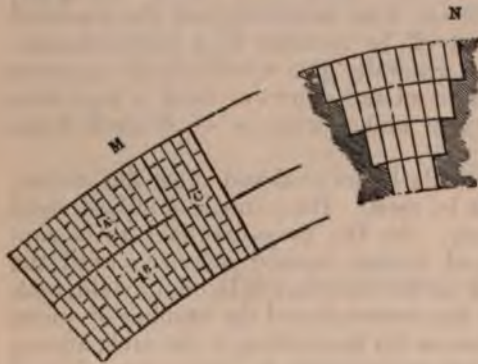

Fig. 80—Represents an end view, M, of a brick arch built with blocks, C, and shells, A and B. N, represents the manner of arranging the courses of brick forming the crown of the arch.

forming continuous joints from the soffit outward, these joints, from the form of the bricks, will be very open at the back, and, from the yielding of the mortar, the arch will be liable to injury in settling from this cause. To obviate both of these defects, the arch may be built partly by the first plan and partly by the second, or as it is termed in shells and *blocks*. The crown, or key of the arch should be laid in a block, increasing the breadth of the block by two bricks for each course from the soffit outward. These bricks should be laid in hydraulic cement, and be well wedged with pieces of thin hard slate between the joints.

509. When a combination of brick and cut stone is used, the

ring courses of the heads, with some intermediate ring courses, the bottom string courses, the keystone course, and a few intermediate string courses, are made of cut stone (Fig. 81), the

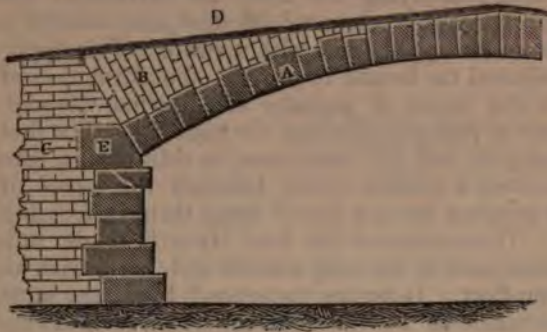

Fig. 81 — Represents a cross section of a stone segment arch, capped with brick and beton. A, stone voussoirs. B and D, brick and beton capping. C, abutment. E, cushion stone.

intermediate spaces being filled in with brick. The brick portions of the soffit may, if necessary, be thrown within the stone portions, forming plain *caissons*.

510. The centres of large arches should not be struck until the whole of the mortar has set firmly. After the centres are struck, the arch is allowed to assume its permanent state of equilibrium, before any of the superstructure is laid.

511. When the heads of the arch form a part of an exterior surface, as the faces of a wall, or the outer portions of a bridge, the voussoirs of the head ring courses are connected with the horizontal courses, as has been explained; the top surface of the voussoirs of the intermediate ring courses are usually left in a roughly dressed state to receive the courses of masonry termed the *capping* (see Fig. 81), which rests upon the arch between the walls of the head. Before laying the capping, the joints of the voussoirs on the back of the arch should be carefully examined, and, wherever they are found to be open from the settling of the arch, they should be filled up with soft-tempered mortar, and by driving in pieces of hard slate. The capping may be variously formed of rubble, brick, or beton. Where the arches are exposed to the filtration of rain water, as in those used for bridges and the casemates of fortifications, the capping should be of beton laid in layers, and well rammed, with the usual precautions for obtaining a solid homogeneous mass.

512. The difficulty of forming water-tight cappings of masonry has led engineers, within a few years back, to try a coating of asphalte upon the surface of beton. The surface

of the beton capping is made uniform and smooth by the trowel, or float, and the mass is allowed to become thoroughly dry before the asphalte is laid. Asphalte is usually laid on in two layers. Before applying the first, the surface of the beton should be thoroughly cleansed of dust, and receive a coating of mineral tar applied hot with a swab. This application of hot mineral tar is said to prevent the formation of air bubbles in the layers of asphalte which, when present, permit the water to percolate through the masonry. The first layer of asphalte is laid on in squares, or thin blocks, care being taken to form a perfect union between the edges of the squares by pouring the hot liquid along them in forming each new one. The surface of the first layer is made uniform, and rubbed until it becomes smooth and hard with an ordinary wooden float. In laying the second layer, the same precautions are taken as for the first, the squares breaking joints with those of the first. Fine sand is strewed over the surface of the top layer, and pressed into the asphalte before it becomes hard.

Coverings of asphalte have been used both in Europe and in our military structures for some years back with decided success. There have been failures, in some instances, arising in all probability either from using a bad material, or from some fault of workmanship.

513. In a range of arches, like those of bridges, or casemates, the capping of each arch is shaped with two inclined surfaces, like a common roof. The bottoms of these surfaces, by their junction, form gutters where the water collects, and from which it is conveyed off in conduits, formed either of iron pipes, or of vertical openings made through the masonry of the piers which communicate with horizontal covered drains. A small arch of sufficient width to admit a man to examine its interior, or a square culvert, is formed over the gutter. When the spaces between the head walls above the capping is filled in with earth, a series of drains running from the top, or *ridge* of the capping, and leading into the main gutter drain, should be formed of brick. They may be best made by using dry brick laid flat, and with intervals left for the drains, these being covered by other courses of dry brick with the joints in some degree open. The earth is filled in upon the upper course of bricks, which should be so laid as to form a uniform surface.

514. From observations taken on the manner in which large cylindrical arches settle, and experiments made on a small scale, it appears that in all cases of arches where the

rise is equal to or less than the half span they yield (Fig. 82) by the crown of the arch falling inward, and thrusting outward the lower portions, presenting five joints of rupture, one at the keystone, one on each side of it which limit the portions that fall inward, and one on each side near the springing lines which limit the parts thrust outward. In



Fig. 82—Represents the manner in which flat arches yield by rupture.  
o, joint of rupture at the keystone.  
m, m, joints of rupture below the keystone.  
n, n, joints of rupture at springing lines.

pointed arches, or those in which the rise is greater than the half span, the tendency to yielding is, in some cases, different; here the lower parts may fall inward (Fig. 83), and thrust upward and outward the parts near the crown.



Fig. 83—Represents the manner in which pointed arches may yield.  
The letters refer to same points as in Fig. 82.

The angle which a line drawn from the centre of the arch to the joint of rupture makes with a vertical line is called the *angle of rupture*. This term is also used when the arch is stable, or when there is no joint of rupture, in which case it refers to that point about which there is the greatest tendency to rotate. It may also be defined as including that portion of the arch near the crown which will cause the greatest *thrust* or horizontal pressure at the crown. This *thrust* tends to crush the *voussoirs* at the crown, and also to overturn the abutments about some outer joint. The thrust is rarely sufficient to crush ordinary stone. The most common mode of failure is by rupturing, or turning about a joint. In very thick arches rupture may take place from *slipping* on the joints.

515. The joints of rupture below the keystone vary in arches of different thicknesses and forms, and in the same arch with the weight it sustains.

516. The problem for finding the joints of rupture by calculation, and the consequent thickness of the abutments necessary to preserve the arch from yielding, has been solved



by a number of writers on the theory of the equilibrium of arches, and tables for effecting the necessary numerical calculations have been drawn up from their results to abridge the labor in each case.

517. In cloistered arches the abutments may be less than in an ordinary cylindrical arch of the same length; and in groined arches, in calculating the resistance offered by the abutments, the counter resistance offered by the weight of one portion in resisting the thrust of the other, must be taken into consideration.

518. When abutments, as in the case of edifices, require to be of considerable height, and therefore would demand extraordinary thickness, if used alone to sustain the thrust of the arch, they may be strengthened by the addition to their weight made in carrying them up above the imposts like the *batilements* and *pinnacles* in Gothic architecture; by adding to them ordinary, full, or arched buttresses, termed *flying buttresses*; or by using ties of iron connecting the *voussoirs* near the joints of rupture below the keystone. Tie-rods are evidently the safest expedient. The employment of these different expedients, their forms and dimensions, will depend on the character of the structure and the kind of arch. The iron tie, for example, cannot be hidden from view except in the *plate-bande*, or in very flat segment arches, and wherever its appearance would be unsightly some other expedient must be tried.

Circular rings of iron have been used to strengthen the abutments of domes, by confining the lower courses of the dome and relieving the abutment from the thrust.

519. In a range of arches of unequal size, the piers will have to sustain a lateral pressure occasioned by the unequal horizontal thrust of the arches. In arranging the form and dimensions of the piers this inequality of thrust must be estimated for, taking also into consideration the position of the imposts of the unequal arches.

520. **Precautions against Settling.** One of the most difficult and important problems in the construction of masonry, is that of preventing unequal settling in parts which require to be connected but sustain unequal weights, and the consequent ruptures in the masses arising from this cause. To obviate this difficulty requires on the part of the engineer no small degree of practical tact. Several precautions must be taken to diminish as far as practicable the danger from unequal settling. Walls sustaining heavy vertical pressures should be built up uniformly, and with great attention to the

bond and correct fitting of the courses. The materials should be uniform in quality and size; hydraulic mortar should alone be used; and the permanent weight not be laid on the wall until the season after the masonry is laid. As a farther precaution, when practicable, a trial weight may be laid upon the wall before loading it with the permanent one.

Where the heads of arches are built into a wall, particularly if they are designed to bear a heavy permanent weight, as an embankment of earth, the wall should not be carried up higher than the imposts of the arches until the settling of the latter has reached its final term; and as there will be danger of disjunction between the piers of the arches and the wall at the head, from the same cause, these should be carried up independently, but so arranged that their after-union may be conveniently effected. It would moreover be always well to suspend the building of the arches until the season following that in which the piers are finished, and not to place the permanent weight upon the arches until the season following their completion.

**521. Pointing.** The mortar in the joints near the surfaces of walls exposed to the weather should be of the best hydraulic lime, or cement, and as this part of the joint always requires to be carefully attended to, it is usually filled, or as it is termed *pointed*, some time after the other work is finished. The period at which pointing should be done is a disputed subject among builders, some preferring to point while the mortar in the joint is still fresh, or *green*, and others not until it has become hard. The latter is the more usual and better plan. The mortar for pointing should be poor, that is, have rather an excess of sand; the sand should be of a fine uniform grain, and but little water be used in tempering the mortar. Before applying the pointing, the joint should be well cleansed by scraping and brushing out the loose matter, and then be well moistened. The mortar is applied with a suitable tool for pressing it into the joint, and its surface is rubbed smooth with an iron tool. The practice among our military engineers is to use the ordinary tools for calking in applying pointing; to calk the joint with the mortar in the usual way, and to rub the surface of the pointing until it becomes hard. *To obtain pointing that will withstand the vicissitudes of our climate is not the least of the difficulties of the builder's art.* The contraction and expansion of the stone either causes the pointing to crack, or else to separate from the stone, and the surface water penetrating into the cracks thus made, when acted upon by frost, throws out the

pointing. Some have tried to meet this difficulty by giving the surface of the pointing such a shape, and so arranging it with respect to the surfaces of the stones forming the joint, that the water shall trickle over the pointing without entering the crack, which is usually between the bed of the stone and the pointing.

522. The term *flash pointing* is sometimes applied to a coating of hydraulic mortar laid over the face or back of a wall, to preserve either the mortar joints, or the stone itself, from the action of moisture, or the effects of the atmosphere. Mortar for flash pointing should also be made poor, and when it is used as a stucco to protect masonry from atmospheric action, it should be made of coarse sand, and be applied in a single uniform coat over the surface, which should be prepared to receive the stucco by having the joints thoroughly cleansed from dust and loose mortar, and being well moistened.

No pointing of mortar has been found to withstand the effects of weather in our climate on a long line of coping. Within a few years a pointing of asphalt has been tried on some of our military works, and has given thus far promise of a successful issue.

523. Stucco exposed to weather is sometimes covered with paint, or other mixtures, to give it durability. Coal tar has been tried, but without success in our climate. M. Raucourt de Charleville, in his work *Traité des Mortiers*, gives the following compositions for protecting exposed stuccoes, which he states to succeed well in all climates. For important work, three parts of linseed oil boiled with one-sixth of its weight of litharge, and one part of wax. For common works, one part of linseed oil, one-tenth of its weight of litharge, and two or three parts of resin.

The surfaces must be thoroughly dry before applying the compositions, which should be laid on hot with a brush.

524. **Repairs of Masonry.** In effecting repairs in masonry, when new work is to be connected with old, the mortar of the old should be thoroughly cleaned off wherever it is injured along the surface where the junction is effected, and the surface thoroughly wet. The bond and other arrangements will depend upon the circumstances of the case; the surfaces connected should be fitted as accurately as practical ble, so that by using but little mortar, no disunion may take place from settling.

525. An expedient, very fertile in its applications to hydraulic constructions, has been for some years in use among the French engineers, for stopping leaks in walls and renew

ing the beds of foundations which have yielded, or have been otherwise removed by the action of water. It consists in injecting hydraulic cement into the parts to be filled, through holes drilled through the masonry, by means of a strong syringe. The instruments used for this purpose (Fig. 83 *a*) are usually cylinders of wood, or of cast iron; the bore uniform, except at the end, which is terminated with a nozzle of the usual conical form; the piston is of wood, and is driven down by a heavy mallet. In using the syringe, it is adjusted to the hole; the hydraulic cement in a semi-fluid state poured

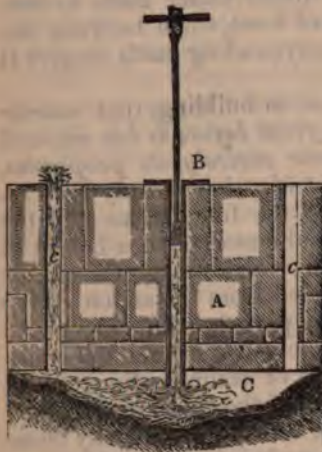

Fig. 83 *a*—Represents the arrangements for injecting hydraulic cement under a wall. A, section of the wall with vertical holes *c, c* drilled through it. B, syringe and piston for injecting the cement into the space *C* under the wall.

into it; a wad of tow, or a disk of leather being introduced on top before inserting the piston. The cement is forced in by repeated blows on the piston.

526. A mortar of hydraulic lime and fine sand has been used for the same purpose; the lime being ground fresh from the kiln, and used before slaking, in order that by the increase of volume which takes place from slaking, it might fill more compactly all interior voids. The use of unslaked lime has received several ingenious applications of this character; its after expansion may prove injurious when confined. The use of sand in mortar for injections has by some engineers been condemned, as from the state of fluidity in which the mortar must be used, it settles to the bottom of the syringe, and thus prevents the formation of a homogeneous mass.

527. **Effects of Temperature on Masonry.** Frost is the most powerful destructive agent against which the engineer has to guard in constructions of masonry. During severe

winters in the northern parts of our country, it has been ascertained, by observation, that the frost will penetrate earth in contact with walls to depths *exceeding ten feet*; it therefore becomes a matter of the first importance to use every practicable means to drain thoroughly all the ground in contact with masonry, to whatever depths the foundations may be sunk below the surface; for if this precaution be not taken, accidents of the most serious nature may happen to the foundations from the action of the frost. If water collects in any quantity in the earth around the foundations, it may be necessary to make small covered drains under them to convey it off, and to place a stratum of loose stone between the sides of the foundations and the surrounding earth to give it a free downward passage.

It may be laid down as a maxim in building, that *mortar which is exposed to the action of frost before it has set, will be so much damaged as to impair entirely its properties.* This fact places in a stronger light what has already been remarked, on the necessity of laying the foundations and the structure resting on them in hydraulic mortar, to a height of at least three feet above the ground; for, although the mortar of the foundations might be protected from the action of the frost by the earth around them, the parts immediately above would be exposed to it, and as those parts attract the moisture from the ground, the mortar, if of common lime, would not set in time to prevent the action of the frosts of winter.

In heavy walls the mortar in the interior will usually be secured from the action of the frost, and masonry of this character might be carried on until freezing weather commences; but still in all important works it will be by far the safer course to suspend the construction of masonry several weeks before the ordinary period of frost.

During the heats of summer, the mortar is injured by a too rapid drying. To prevent this the stone, or brick, *should be thoroughly moistened before being laid; and afterwards, if the weather is very hot, the masonry should be kept wet until the mortar gives indications of setting.* The top course should always be well moistened by the workmen on quitting their work for any short period during very warm weather.

The effects produced by a high or low temperature on mortar in a green state are similar. In the one case the freezing of the water prevents a union between the particles of the lime and sand; and in the other the same arises from the water being rapidly evaporated. In both cases the mortar when it has set is weak and pulverulent.

## CHAPTER IV.

### FRAMING.

528. FRAMING is the art of arranging beams of solid materials for the various purposes to which they are applied in structures. A *frame* is any arrangement of beams made for sustaining strains.

529. That branch of framing which relates to the combinations of beams of timber is denominated *Carpentry*.

530. Timber and iron are the only materials in common use for frames, as they are equally suitable to resist the various strains to be met with in structures. Iron, independently of offering greater resistance to strains than timber, possesses the further advantage of being susceptible of receiving the most suitable forms for strength without injury to the material; while timber, if wrought into the best forms for the object in view, may, in some cases, be greatly injured in strength.

531. The object to be attained in framing is to give, by a suitable combination of beams, the requisite degree of strength and stiffness demanded by the character of the structure, united with a lightness and an economy of material of which an arrangement of a massive kind is not susceptible. To attain this end, the beams of the frame must be of such forms, and be so combined that they shall not only offer the greatest resistance to the efforts they may have to sustain, but shall not change their relative positions from the effect of these efforts.

532. The forms of the beams will depend upon the kind of material used, and the nature of the strain to which it may be subjected, whether of tension, compression, or a cross strain.

533. The general shape given to the frame, and the combinations of the beams for this purpose, will depend upon the object of the frame and the directions in which the efforts act upon it.

In frames of timber, for example, the cross sections of each beam are generally uniform throughout, these sections being either circular, or rectangular, as these are the only simple

forms which a beam can receive without injury to its strength. In frames of cast-iron, each beam may be cast into the most suitable form for the strength required, considering the economy of the material.

534. In combining the beams, whatever may be the general shape of the frame, the parts which compose it must, as far as practicable, present triangular figures, each side of the triangles being formed of a single beam; the connection of the beams at the angular points, termed the *joints*, being so arranged that no yielding can take place. In all combinations, therefore, in which the principal beams form polygonal figures, secondary beams must be added, either in the directions of the diagonals of the polygon, or so as to connect each pair of beams forming an angle of the polygon, for the purpose of preventing any change of form of the figure, and of giving the frame the requisite stiffness. These secondary pieces receive the general appellation of *braces*. When they sustain a strain of compression they are termed *struts*; when one of extension, *ties*.

535. As one of the objects of a frame is to transmit the strain it directly receives to firm points of support, the beams of which it is formed should be so combined that this may be done in the way which shall have the least tendency to change the shape of the frame and to fracture the beams.

536. The points of support of a frame may be either above or below it. In the former case, the frame will consist of a suspended system, in which the polygon will assume a position of stable equilibrium, its sides being subjected to a strain of extension. In the latter case the frame, if of a polygonal form, must satisfy the essential conditions already enumerated, in order that its state of equilibrium shall be stable.

537. The object of the structure will necessarily decide the general shape of the frame, as well as the direction of the strains to which it will be subjected. An examination, therefore, of the frames adapted to some of the more usual structures will be the best course for illustrating both the preceding general principles and the more ordinary combinations of the beams and joints.

538. **Frames for Cross Strains.** The parts of a frame which receive a cross strain may be horizontal, as the beams, or *joists* of a floor; or inclined, as the beams, or *rafters* which form the inclined *struts* of the frame of a roof. The pressure producing the cross strain may either be uniformly distributed over the beams, as in the cases just cited, or it

may act only at one point, as in the case of a weight laid upon the beam.

In all of these cases the extremities of the beam should be firmly fixed against immovable points of support; the longer side of the rectangular section of the beam should be parallel to the direction of the strain, as this is the best position for strength.

If the distance between the points of support, or the *bearing*, be not great, the framing may consist simply of a row of parallel beams of such dimensions, and placed so far asunder as the strain borne may require. When the beams are



Fig. 84—Represents a cross section of horizontal beams *a*, a brace by diagonal battens *b*.

narrow, or the depth of the rectangle considerably greater than the breadth (Fig. 84), short struts of battens may be placed at intervals between each pair of beams, in a diagonal direction, uniting the bottom of the one with the top of the other, to prevent the beams from twisting, or yielding laterally. This also increases the stiffness of the structure by distributing the strains.

539. When the bearing and strain are so great that a single beam will not present sufficient strength and stiffness, a combination of beams, termed a *built beam*, which may be *solid*, consisting of several layers of timber laid in juxtaposition, and firmly connected together by iron bolts and straps—or *open*, being formed of two beams, with an interval between them, so connected by cross and diagonal pieces, that a strain upon either the upper or lower beam will be transmitted to the other, and the whole system act under the effect of the strain like a solid beam.

540. **Solid built Beams.** In framing solid built beams, the pieces in each course (Fig. 85) are laid abutting end to



Fig. 85—Represents a solid built beam of three courses, the pieces of each course breaking joints and confined by iron hoops.

end with a square joint between them, the courses breaking joints to form a strong bond between them. The courses are firmly connected either by iron bolts, formed with a screw and nut at one end to bring the courses into close con-



tact, or else by iron bands driven on tight, or by iron stirrups (Fig. 86) suitably arranged with screw ends and nuts for the same purpose.



Fig. 86—Represents an iron stirrup or hoop with nuts or female screws c which confine the cross piece of the stirrup b.

When the strain is of such a character that the courses would be liable to work loose and slide along their joints, the beams of the different courses may be made with shallow indentations (Figs. 87, 88), accurately fitting into each other ;

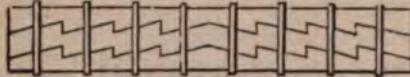

Fig. 87—Represents a solid built beam of three courses arranged with indentations and confined by iron hoops.

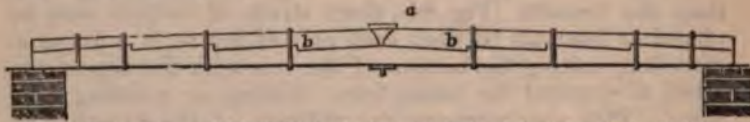

Fig. 88—Represents a solid built beam, the top part being of two pieces b, b which abut against a broad flat iron bolt a, termed a king bolt.

or shallow rectangular notches (Fig. 89) may be cut across each beam, being so placed as to receive blocks, or keys of

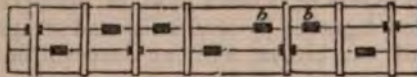

Fig. 89—Represents a solid built beam with keys b, b of hard wood between the courses.

hard wood. The keys are sometimes made of two wedge



Fig. 90—Represents the keys in the form of double, or folding wedges a, b let into a shallow notch in the beam c.

shaped pieces (Fig. 90), for the purpose of causing them to fit the notches more closely, and to admit of being driven tight upon any shrinkage of the woody fibre.

The joints between the courses may be left slightly open without impairing in an appreciable degree the strength of the combination. This is a good method in beams exposed to

moisture, as it allows of evaporation from the free circulation of the air through the joints. Felt, or stout paper saturated with mineral tar, has been recommended to secure the joints from the action of moisture. The prepared material is so placed as to occupy the entire surface of the joint, and the whole is well screwed together.

**541. Joints.** A joint is the surface between two pieces which come in contact with each other, and which are connected together. The form and arrangement of joints will depend upon the relative position of the beams joined, and the object of the joint.

In all arrangements of joints, the axes of the beams connected should lie in the same plane in which the strain upon the frame acts; and the combination should be so arranged that the parts will accurately fit when the frame is put together, and that any portion may be displaced without disconnecting the rest. The simplest forms most suitable to the object in view will usually be found to be the best.

In adjusting the surfaces of the joints an allowance should be made for any settling in the frame which may arise either from the shrinking of the timber in seasoning while in the frame, or from the fibres yielding to the action of the strain. This is done by leaving sufficient play in the joints when the frame is first set up, to admit of the parts coming into perfect contact when the frame has attained its final settling. Joints formed of plane surfaces present more difficulty in this respect than curved joints, as the bearing surfaces in the latter case will remain in contact should any slight change take place in the relative positions of the beams from settling; whereas in the former a slight settling might cause the strains to be thrown upon a corner, or edge of the joint, by which the bearing surfaces might be crushed, and the parts of the framework wrenched asunder from the leverage which such a circumstance might occasion.

The surface of a joint subjected to pressure should be as great as practicable, to secure the parts in contact from being crushed by the strain; and the surface should be nearly perpendicular to the direction of the strain to prevent sliding.

A thin plate of iron, or lead, may be inserted between the surfaces of joints where, from the magnitude of the strain, one of them is liable to be crushed by the other, as in the case of the end of one beam resting upon the face of another.

**542.** Folding wedges, and pins, or *tree-nails*, of hard wood, are used to bring the surfaces of joints firmly to their bearings, and retain the parts of the frame in their places. The

wedges are inserted into square holes, and the pins into auger-holes made through the parts connected. As the object of these accessories is simply to bring the parts connected into close contact, they should be carefully driven, in order not to cause a strain that might crush the fibres.

To secure joints subjected to a heavy strain, bolts, straps, and hoops of wrought iron are used. These should be placed in the best direction to counteract the strain and prevent the parts from separating; and wherever the bolts are requisite they should be inserted at those points which will least weaken the joint.

**543. Joints of Beams united end to end.** When the axes of the beams are in the same right line, the form of the joint will depend upon the direction of the strain. If the strain is one of compression, the ends of the beams may be united by a square joint perpendicular to their axes, the joint being secured (Fig. 91) by four short pieces so placed as to embrace

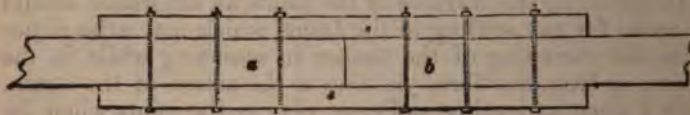

Fig. 91—Represents the manner in which the end joint of two beams *a* and *b* is fished or secured by side pieces *c* and *d* bolted to them.

the ends of the beams, and being fastened to the beams and to each other by bolts. This arrangement, termed *fishing a beam*, is used only for rough work. It may also be used when the strain is one of extension; in which case the short pieces (Fig. 92) may be notched upon the beams, or else keys



Fig. 92—Represents a fished joint in which the side pieces *c* and *d* are either let into the beams or secured by keys *e*, *e*.

of hard wood, inserted into shallow notches made in the beams and short pieces, may be employed to give additional security to the joint.

A joint termed a *scarf* may be used for either of the foregoing purposes. This joint may be formed either by halving



Fig. 93—Represents a scarf joint secured by iron plates *c, c*, keys *d, d*, and bolts.

the beams on each other near their ends (Fig. 93), and securing the joints by bolts, or straps; or else by so arranging the ends of the two beams that each shall fit into shallow triangular notches cut into the other, the joint being secured by iron hoops. This last method is employed for round timber.

544. When beams united at their ends are subjected to a cross strain, a scarf joint is generally used, the under part of the joint being secured by an iron plate confined to the beams by bolts. The scarf for this purpose may be formed simply by halving the beams near their ends; but a more usual and better form (Fig. 94) is to make

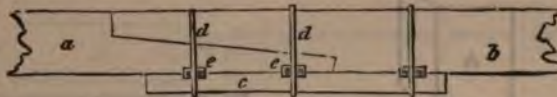

Fig. 94—Represents a scarf joint for a cross strain secured at bottom by a piece of timber *c* confined to the beams by iron hoops *d, d* and keys *e, e*.

the portion of the joint at the top surface of the beams perpendicular to their axes, and about one third of their depth; the bottom portion being oblique to the axis, as well as the portion joining these two.

When the beams are subjected to a cross strain and to one of extension in the direction of their axes, the form of the scarf must be suitably arranged to resist each of these strains. The one shown in Fig. 95 is a suitable and usual form for



Fig. 95—Represents a scarf joint arranged to resist a cross strain and one of extension. The bottom of the joint is secured by an iron plate confined by bolts. The folding wedge key inserted at *c* serves to bring all the surfaces of the joints to their bearings.

these objects. A folding wedge key of hard wood is inserted into a space left between the parts of the joint which catch when the beams are drawn apart. The key serves to bring the surfaces of the joints to their bearings, and to form an abutting surface to resist the strain of extension. In this

form of scarf the surface of the joint which abuts against the key will be compressed; the portions of the beams just above and below the key will be subjected to extension. These parts should present the same amount of resistance, or have an equality of cross section. The length of the scarf should be regulated by the resistance with which the timber employed resists detrusion compared with its resistance to compression and extension.

545. When the axes of beams form an angle between them, they may be connected at their ends either by halving them on each other, or by cutting a mortise in the centre of one beam at the end, and shaping the end of the other to fit into it. See Fig. 97.

546. Joints for connecting the end of one beam with the face of another. The joints used for this purpose are termed *mortise and tenon joints*. Their form will depend upon the angle between the axes of the beams.

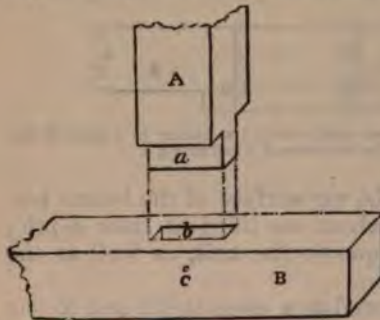

Fig. 96—Represents a mortise and tenon joint when the axes of the beams are perpendicular to each other.  
*a*, tenon on the beam A.  
*b*, mortise in the beam B.  
*c*, pin to hold the parts together.

When the axes are perpendicular to each other, the mortise (Fig. 96) is cut into the face of the beam, and the end of the other beam is shaped into a tenon to fit the mortise.

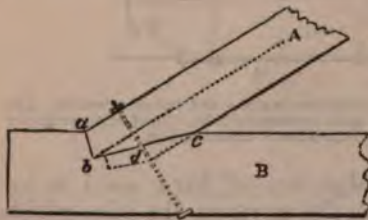

Fig. 97—Represents a mortise and tenon joint when the axes of the beams are oblique to each other. A notch whose surfaces *ab* and *bc* are at right angles is cut into the beam B, and a shallow mortise *d* is cut below the surface *bc*. The end of the beam A is arranged to fit the notch and mortise in B. The joint is secured by a screw bolt.

When the axes of the beams are oblique to each other, a triangular notch (Fig. 97) is usually cut into the face of

one beam, the sides of the notch being perpendicular to each other, and a shallow mortise is cut into the lower surface of the notch; the end of the other beam is suitably shaped to fit the notch and mortise.

The direction of the strain and the effect it may produce upon the joint must in all cases regulate its form. In some cases the circular joint may be more suitable than those forms which are plane surfaces; in others a double tenon may be better than the simple joint.

**547. Tie Joints.** These joints are used to connect beams which cross, or lie on each other. The simplest and strongest form of tie joint consists in cutting a notch in one or both of the beams to connect them securely. But when the beams do not cross, but the end of one rests upon the other, a notch of a trapezoidal form (Fig. 98) may be cut in the lower beam

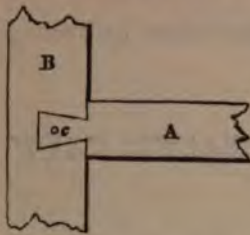

Fig. 98—Represents an ordinary dove-tail joint secured by a pin at c.

to receive the end of the upper, which is suitably shaped to fit the notch. This, from its shape, is termed a *dove-tail joint*. It is of frequent use in joinery, but is not suitable for heavy frames where the joints are subjected to considerable strains, as it soon becomes loose from the shrinking of the timber.

**548. Open built Beams.** In framing open built beams, the principal point to be kept in view is to form such a connection between the upper and lower solid beams, that they shall be strained uniformly by the action of a strain at any point between the bearings. This may be effected in various ways, (Fig. 99.) The upper and lower beams may consist



Fig. 99—Represents an open built beam; A and B are the top and bottom rails or strings; a, a, cross pieces, either single or in pairs; b, diagonal braces in pairs; c, single diagonal braces.

either of single beams or of solid built beams; these are connected at regular intervals by pieces at right angles to them, between which diagonal pieces are placed. By this arrange-

ment the relative position of all the parts of the frame will be preserved, and the strain at any point will be brought to bear upon the intermediate points.

549. **Framing for intermediate Supports.** Beams of ordinary dimensions may be used for wide bearings when intermediate supports can be procured between the extreme points.

The simplest and most obvious method of effecting this is to place upright beams, termed *props*, or *shores*, at suitable intervals under the supported beam.

When the props would interfere with some other arrangement, and points of support can be procured at the extremities below those on which the beam rests, inclined struts (Fig. 100) may be used. The struts must have a suitable step at the foot, and be connected at top with the beam by a suitable joint.

In some cases the bearing may be diminished by placing



Fig. 100—Represents a horizontal beam *C* supported near the middle by inclined struts *A, A*.

on the points of support short pieces, termed *corbels* (Fig. 101), and supporting these near their ends by struts.

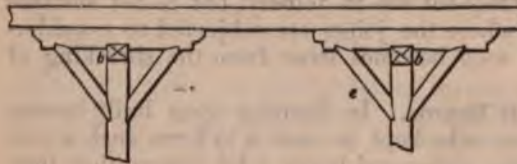

Fig. 101—Represents a horizontal beam *c* supported by vertical posts *a, a*, with corbel pieces *d, d* and inclined struts *e, e* to diminish the bearing.

In other cases a portion of the beam, at the middle, may be strengthened by placing under it a short beam, called a

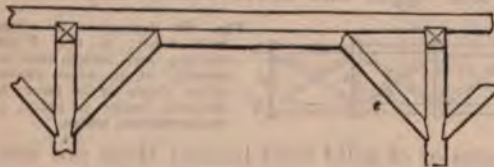

Fig. 102—Represents a horizontal beam *c*, strengthened by a straining beam *f* and inclined struts *e, e*.

*straining beam* (Fig. 102), against the ends of which the struts abut.

Whenever the bearing may require it the two preceding arrangements (Fig. 103) may be used in connection.



Fig. 103—Represents a combination of Figs. 101 and 102.

In all combinations with struts, a lateral thrust will be thrown on the point of support where the foot of the strut rests. This strain must be provided for in proportioning the supports.

550. When intermediate supports can be procured only above the beam, an arrangement must be made which shall answer the purpose of sustaining the beam at its intermediate points by suspension. The combination will depend upon the number of intermediate points required.

When the beam requires to be supported only at the middle, it may be done as shown in Fig. 104. If the suspending piece be of iron, it must be arranged at one end with a screw and nut. When the support is of timber, a single beam, called a *king post*, (Fig. 104,) may be used, against the head

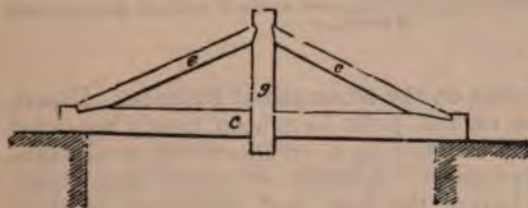

Fig. 104—Represents a horizontal beam *c* supported in its middle by a king post *g* suspended from the struts *e, e*.

of which the two inclined pieces may abut; the foot of the post is connected with the beam by a bolt, an iron stirrup, or a suitable joint. Instead of the ordinary king post, two beams may be used; these are placed opposite to each other and bolted together, embracing between them the supported beam and the heads of the inclined beams which fit into shallow notches cut into the supporting beams. Pieces arranged



in this manner for suspending portions of a frame receive the name of *suspension pieces*, or *bridle pieces*.

When two intermediate points of support are required, they may be obtained as shown in Fig. 105. The suspension

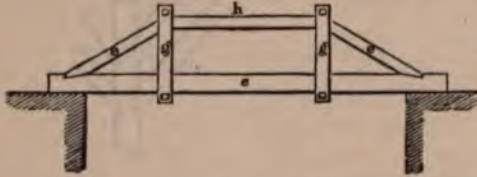

Fig. 105—Represents a beam *c* supported at two points by posts *g, g* suspended from the struts *e, e* and straining beam *h*.

pieces in this case may be either posts, termed *queen posts*, arranged like a king post, iron rods, or bridle pieces. This combination may be used for very wide bearings, (Fig. 106,) by suitably increasing the number of inclined pieces and straining beam.

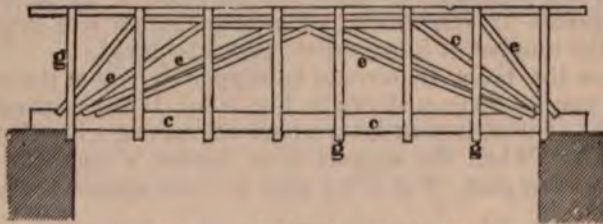

Fig. 106—Represents a beam *c* suspended from a combination of struts and straining beams by posts *g, g*.

**551. Experiments on the Strength of Frames.** Experimental researches on this point have been mostly restricted to those made with models on a comparatively small scale, owing to the expense and difficulty attendant upon experiments on frames having the form and dimensions of those employed in ordinary structures.

Among the most remarkable experiments on a large scale, are those made by order of the French government at Lorient, under the direction of M. Riebell, the superintending engineer of the port, and published in the *Annales Maritimes et Coloniales*, Feb. and Nov., 1837.

The experiments were made by first setting up the frame to be tried, and, after it had settled under the action of its

own weight, suspending from the back of it, by ropes placed at equal intervals apart, equal weights to represent a load uniformly distributed over the back of the frame.

The results contained in the following table are from experiments on a truss (Fig. 107) for the roof of a ship shed. The truss consisted of two rafters and a tie beam, with sus-

Fig. 107.



pension pieces in pairs, and diagonal iron bolts, which were added because it was necessary to scarf the tie beam. The span of the truss was  $65\frac{1}{2}$  feet; the rafters had a slope of 1 perpendicular to 4 base. The thickness of the beams, measured horizontally, was about  $2\frac{1}{2}$  inches, their depth about 18 inches. The amount of the settling at each rope was ascertained by fixed graduated vertical rods, the measures being taken below a horizontal line marked 0.

WEIGHTS BORNE BY THE TRUSS.	Amount of settling on the right of the ridge below the horizontal 0, in inches.				
	At 18 inches from the ridge.	At 4 ft. 6 in. from the ridge.	At 8 ft. from the ridge.	At 10 ft. from the ridge.	At 15 ft. from the ridge.
Weight uniformly distributed, 1654 lbs. ....	0.15	0.15	0.15	0.15	0.15
Do. do. 8680 lbs. ....	1.6	1.7	1.9	1.8	1.1
Do. do. 1654 lbs. and 1368 lbs., suspended from the centre of the frame. ....	0.4	0.5	0.4	0.3	0.2
8680 lbs., uniformly distributed, and 1368 lbs. from the centre. ....	2.0	2.1	2.3	2.1	1.2

The following table gives the results of experiments made on frames of the usual forms of straight and curved timber for roof trusses. The curved pieces were made of two thicknesses, each  $3\frac{1}{2}$  inches. The numbers in the fifth column give the ratios between the weight of the frame and that of the weight borne by which the elasticity was not impaired.

DESCRIPTION OF THE FRAMES.	Span, or bearing.	Rise, or versed sine.	Depth of beams.	Horizontal breadth of beams.	Elastic between weight in lbs. of frame, and that of the load borne.	Weight borne without impairing elasticity of the wood.	Weight by which the elasticity was visibly changed.
Frame formed of two rafters and a tie beam..	25 ft.	8 ft.	8.5 in.	3.1 in.	14.30	2305	3016
Do. do. do. and suspension pieces in pairs, (Fig. 108)	.....	.....	.....	.....	8.88	2770	5520
Frame of a segment arch confined by a tie beam, (Fig. 109).....	54 ft.	11 ft.	12 in.	7 in.	3.85	6530	12240
Do. do. do. with suspension pieces in pairs, (Fig. 110)...	.....	.....	.....	.....	2.82	9500	18077
Frame of a segment arch with rafters confined at their foot by a tie piece, (Fig. 111)...	.....	.....	.....	.....	3.91	6111	21896
Frame of a full centre arch confined by a tie beam .....	50 ft.	25 ft.	.....	.....	1.00	4336	5161
Do. do. do. with suspension pieces in pairs.....	.....	.....	.....	.....	0.91	7339	8153

Fig. 108.

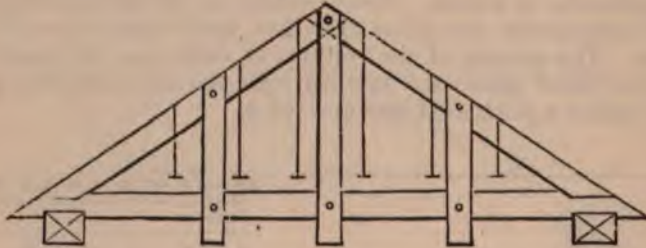

Fig. 109.



Fig. 110.

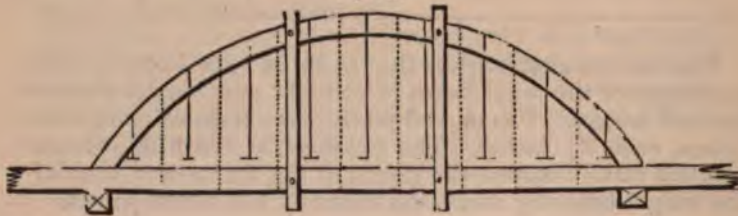

Fig. 111.

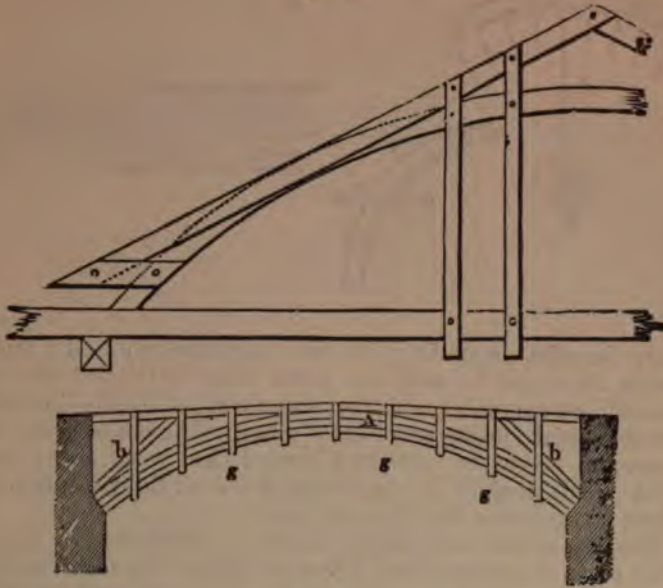

Fig. 112—Represents a wooden arch A formed of a solid built beam of three courses which support the beams c, c by the posts g, g which are formed of pieces in pairs. b, b, inclined struts to strengthen the arch by relieving it of a part of the load on the beams c, c.

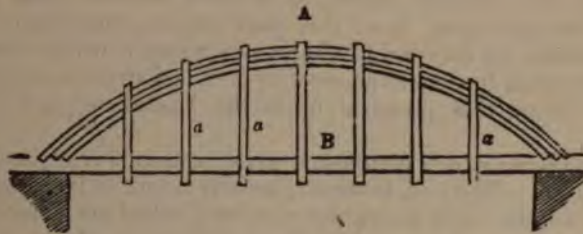

Fig. 113—Represents a wooden arch of a solid built beam A which supports the horizontal beam B by means of the posts a, a. The arch is let into the beam B, which acts as a tie to confine its extremities.

552. Wooden arches may also be formed by fastening together several courses of boards, giving the frame a polygonal form, (Fig. 114,) corresponding to the desired curvature, and then shaping the outer and inner edges of the arch to the proper curve. Each course is formed of boards cut into

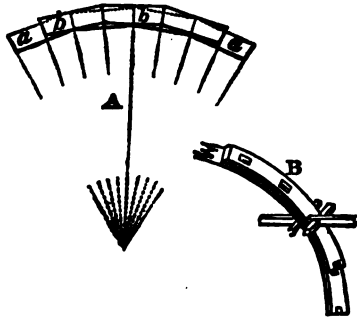

Fig. 114—Represents an elevation A of a wooden arch formed of short pieces a, b which abut end to end and break joints. B represents a perspective view of this combination, showing the manner in which the parts are keyed together.

sharp lengths, depending on the curvature required; these pieces abut end to end, the joints being in the direction of the radii of curvature, and the pieces composing the different courses break joints with each other. The courses may be connected either by jibs and keys of hard wood, or by iron bolts. This method is very suitable for all light framework where the pressure borne is not great.

Wooden arches are chiefly used for bridges and roofs. They serve as intermediate points of support for the framing on which the roadway rests in the one case, and the roof covering in the other. In bridges the roadway may lie either above the arch, or below it; in either case vertical posts, iron rods, or bridles connect the horizontal beams with the arch.

553. The greatest strain in wooden arches takes place near the springing line; this part should, therefore, when practicable, be relieved of the pressure that it would directly receive from the beams above it by inclined struts, so arranged as to throw this pressure upon the lateral supports of the arch.

The pieces which compose a wooden arch may be bent into any curve. The one, however, usually adopted is an arc of a circle, as the most simple for the mechanical construction of the framing, and presenting all desirable strength.

## CHAPTER V.

### BRIDGES.

- I. CLASSIFICATION. II. STONE BRIDGES. III. WOODEN BRIDGES. IV. CAST-IRON BRIDGES. V. WROUGHT-IRON TRUSS BRIDGES. VI. TUBULAR BRIDGES. VII. SUSPENSION BRIDGES. VIII. SWING BRIDGES. IX. AQUEDUCT BRIDGES.

#### I.

##### CLASSIFICATION.

554. A *bridge* is a structure for supporting a roadway over a body or stream of water, or over a depression in the earth.

If the structure is over a depression in which there is usually no water, it is called a *viaduct*.

If the structure supports a water-way, it is called an *aqueduct*, and if the aqueduct is over a river, it is sometimes called an *aqueduct-bridge*.

Bridges may be classed according to their mechanical features; in which case we have—

1. Arches.
2. Trussed bridges.
3. Tubular bridges.
4. Suspension bridges.

They may also be classed according to the materials which compose them; as Stone, Wood, and Iron.

The former is more convenient for the purposes of analysis, but the latter will be used in this work.

#### II.

##### STONE BRIDGES.

555. A stone bridge consists of a roadway which rests upon one or more arches, usually of a cylindrical form, the abutments and piers of the arches being of sufficient height and strength to secure them and the roadway from the effects of an extraordinary rise in the water-course.

556. The general location of a bridge will depend upon the approaches, and the particular locality may be modified by the character of the banks, the soil or subsoil, and the bends in the stream. High embankments and deep excavations will naturally be avoided, if possible. The faces of the piers and abutments should be nearly or quite parallel to the thread of the stream.

557. **Survey.** With whatever considerations the locality may have been selected, a careful survey must be made not only of it, but also of the water-course and its environs for some distance above and below the point which the bridge will occupy, to enable the engineer to judge of the probable effects which the bridge, when erected, may have upon the natural regimen of the water-course.

The object of the survey will be to ascertain thoroughly the natural features of the surface, the nature of the subsoil of the bed and banks of the water-course, and the character of the water-course at its different phases of high and low water, and of freshets. This information will be embodied in a topographical map; in cross and longitudinal sections of the water-course and the substrata of its bed and banks, as ascertained by soundings and borings; and in a descriptive memoir which, besides the usual state of the water-course, should exhibit an account of its changes, occasioned either by permanent or by accidental causes, as from the effects of extraordinary freshets, or from the construction of bridges, dams, and other artificial changes either in the bed or banks.

558. **Water-way.** When the natural water-way of a river is obstructed by any artificial means, the contraction, if considerable, will cause the water, above the point where the obstruction is placed, to rise higher than the level of that below it, and produce a fall, with an increased velocity due to it, in the current between the two levels. These causes, during heavy freshets, may be productive of serious injury to agriculture, from the overflowing of the banks of the water-course;—may endanger if not entirely suspend navigation, during the seasons of freshets;—and expose any structure which, like a bridge, forms the obstruction, to ruin, from the increased action of the current upon the soil around its foundations. If, on the contrary, the natural water-way is enlarged at the point where the structure is placed, with the view of preventing these consequences, the velocity of the current, during the ordinary stages of the water, will be decreased, and this will occasion deposits to be formed at the point, which, by gradually filling up the bed, might, on a

sudden rise of the water, prove a more serious obstruction than the structure itself; particularly if the main body of the water should happen to be diverted by the deposit from its ordinary channels, and form new ones of greater depth around the foundations of the structure.

The water-way left by the structure should, for the reasons above, be so regulated that no considerable change shall be occasioned in the velocity of the current through it during the most unfavorable stages of the water.

559. For the purpose of deciding upon the most suitable velocity for the current through the contracted water-way formed by the structure, the velocity of the current and its effects upon the soil of the banks and bed of the natural water-way should be carefully noted at those seasons when the water is highest; selecting, in preference, for these observations, those points above and below the one which the bridge is to occupy, where the natural water-way is most contracted.

560. The velocity of the current at any point may be ascertained by the simple process of allowing a light ball, or *float* of some material, like white wax, or camphor, whose specific gravity is somewhat less than that of water, to be carried along by the current of the middle thread of the water-course, and noting the time of its passage between two fixed stations.

561. From the velocity at the surface, ascertained in this way, the average, or *mean velocity* of the water, which flows through the cross-section of any water-way between the stations where the observations are taken, is nearly four-fifths of the velocity at the surface.

Having the mean velocity of the natural water-way, that of the artificial water way will be obtained from the following expression,

$$v = m \frac{S}{s} V,$$

in which  $s$  and  $v$  represent, respectively, the area and mean velocity of the artificial water-way;  $S$  and  $V$ , the same data of the natural water-way; and  $m$  a constant quantity, which, as determined from various experiments, may be represented by the mixed number 1.097.

With regard to the effect of the increased velocity on the bed, there are no experiments which directly apply to the cases usually met with. The following table is drawn up from experiments made in a confined channel, the bottom and sides of the channel being formed of rough boards:—



Stages of accumulation termed	Velocity of river in feet per second.	Nature of the bottom which just bears such velocities.	Specific gravity of the material.
Ordinary floods....	3.2	Angular stones, the size of a hen's egg..	2.35
	2.17	Rounded pebbles one inch in diameter..	2.614
	1.07	Gravel of the size of garden beans.....	2.545
Uniform tenors ...	0.62	Gravel of the size of peas.....	2.545
	0.71	Coarse yellow sand.....	2.36
Gliding.....	0.351	Sand, the grains the size of aniseeds... ..	2.545
Dull.....	0.26	Brown potters' clay.....	2.64

**562. Bays.** As a general rule, there should be an odd number of bays, whenever the width of the water-way is too great to be spanned by a single arch. Local circumstances may require a departure from this rule; but when departed from, it will be at the cost of architectural effect; since no secondary feature can occupy the central point in any architectural composition without impairing the beauty of the structure to the eye; and as the arches are the main features of a stone bridge, the central point ought to be occupied by one of them.

The width of the bays will depend mainly upon the character of the current, the nature of the soil upon which the foundations rest, and the kind of material that can be obtained for the masonry.

For streams with a gentle current, which are not subject to heavy freshets, narrow bays, or those of a medium size may be adopted, because, even a considerable diminution of the natural water-way will not greatly affect the velocity under the bridge, and the foundations therefore will not be liable to be undermined. The difficulty, moreover, of laying the foundations in streams of this character is generally inconsiderable. For streams with a rapid current, and which are, moreover, subject to great freshets, wide bays will be most suitable, in order, by procuring a wide water-way, to diminish the danger to the points of support, in placing as few in the stream as practicable.

**563. Classification of Arches.** Arches are classed, according to their concave surface, as: *cylindrical, conical, conoidal, warped, annular, groined, cloistered, and domes.*

A *right arch* is one in which the axis is perpendicular to the face; and an *oblique arch* is one in which the axis is not perpendicular to the face.

A *rampant arch* is one in which the axis is not in a horizontal plane.

**564. Surfaces of the Arch.** The *sffit* is the inner concave surface.

The *back* is the external surface.

The *face* of the arch is the end surface.

565. **Lines of the Arch.** The *springing lines* are the intersections of the soffit with the abutment; as  $a', c'$ , Fig. 121. In Fig. 115, B is the projection of a springing line

The *span* is the chord of the curve of right section, as DB, Fig. 115.

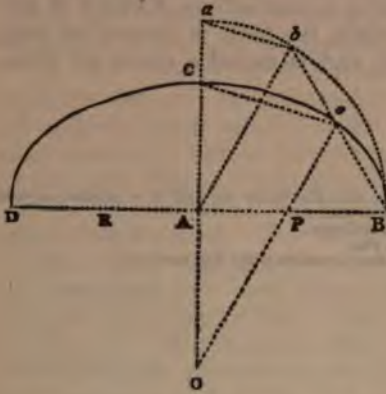

Fig. 115—Represents an oval curve of three centres, the arcs of which are each  $60^\circ$ .  
DB, span of the curve,  
AC, rise,  
P, O, and R, centres of the arcs of  $60^\circ$ .  
DCB is the intrados.

The *axis* of the arch is the line passing through the centres of the span.

The *rise* is the versed sine of the curve of right section, as AC, Fig. 115.

The *intrados* is the intersection of the soffit with the face of the arch, as DCB.

The *extrados* is the intersection of the back of the arch with the face.

The intrados may be defined as the inner curve of a vertical right section, and the extrados as the outer one.

The *crown* is the highest line of the soffit.

The *coursing joints* are those lines which run lengthwise of the arch, and separate the several courses of the stones.

The *heading* or *ring joints* are those lines which separate the stones, and are nearly or quite parallel to the face of the arch.

566. **Volumes of the Arch.** The blocks of stone which form the body of the arch are called *vousoirs*.

The *keystone* is the highest stone of the arch.

The *impost* stones are the highest stones of the abutment, and upon which the arch directly rests.

567. **Cylindrical Arch.** This is the most usual and the simplest form of arch. The soffit consists of a portion of a cylindrical surface. When the section of the cylinder perpendicular to the axis of the arch, termed a *right section*, cuts from the surface a semicircle, the arch is termed a *full centre arch*; when the section is an arc less than a semicircle, it is termed a *segmental arch*; when the section gives a semi-ellipse, it is termed an *elliptical arch*; when the section gives a curve resembling a semi-ellipse, formed of arcs of circles tangent to each other, the arch is termed an *oval*, (Fig. 115, or *basket handle*), and is called a curve of *three*,

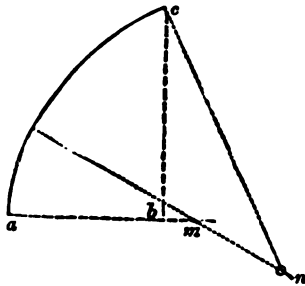

Fig. 116—Represents the half of a pointed curve of four centres,  
 $ab$ , half span,  
 $bc$ , rise,  
 $m$  and  $n$ , centres of the half curve  $ac$ .

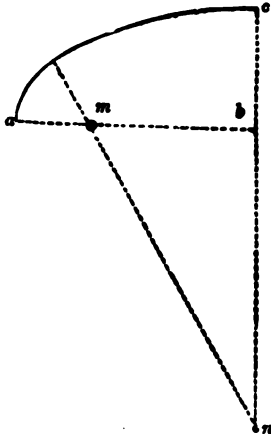

Fig. 117—Represents the half of an obtuse or surbased curve of four centres,  
 $ab$ , half span,  
 $bc$ , rise,  
 $m$  and  $n$ , centres of the half curve  $ac$ .

*five, seven, etc.*, centres. In order to make the curve horizontal at the crown and symmetrical in reference to a vertical line through the centre, there must be an odd number of arcs. When the intrados is composed of two arcs meeting at the highest point of the curve, it is called a *pointed*, (Fig. 116,) or an *obtuse or surbased arch*, (Fig. 117.)

**568. Oblique Arches.** If the obliquity of the arch is small, it may be constructed like the right arch, but when the obliquity is considerable, or in other words when the angle between the axis and face is considerably less or greater than 90 degrees, the pressure upon the voussoirs near the end of the springing lines would be very oblique to the beds, and at the acute angles would tend to force the voussoirs out of place if the coursing joints are made parallel to the axis. To obviate this defect the coursing joints are inclined to the cylindrical elements, as will now be explained.

An ideal mode of determining the coursing joints is to conceive the arch to be intersected by an indefinite number of vertical planes parallel to the face, thus making an indefinite number of curves like the end ones. Then begin at any point, as *d*, Fig. 118, and pass a line along the soffit so as to cut all the former curves at right angles, and we have an ideal coursing joint. The line *d c*, Fig. 118, represents such a line. Other similar curves are also shown. The equation of these when developed is logarithmic. They are all asymptotes to the springing line. The plan of these curves is shown in Fig. 119. A suitable number of vertical intersections may be selected for determining the ring-joints, portions of which only are used, as *b a*, Fig. 118, and *b' a'*, Fig. 119.

Fig. 118.

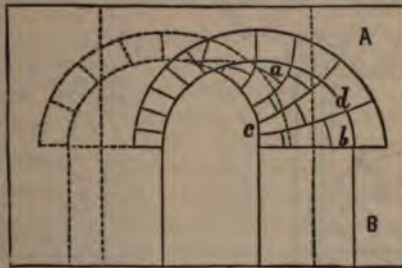

Fig. 118—Elevation of an oblique arch, in which the coursing joints *d c*, etc., are normal to the ring-joints, *b a*, etc. B is the abutment. A the filling over the back.

Fig. 119—Plan of the oblique arch shown in Fig. 118, showing the plan of the coursing joint and heading joints.



Fig. 119.

This mode of determining the coursing joints is very objectionable in practice, because the voussoirs must constantly vary in width as we pass from one end to the other; and as the bed-surfaces are warped, it makes it exceedingly difficult to make the voussoirs of proper shape.

The method of making the coursing joints nearly or quite parallel to each other, sometimes called the English method, is more simple, and gives as good results as the preceding method.

Fig. 120.

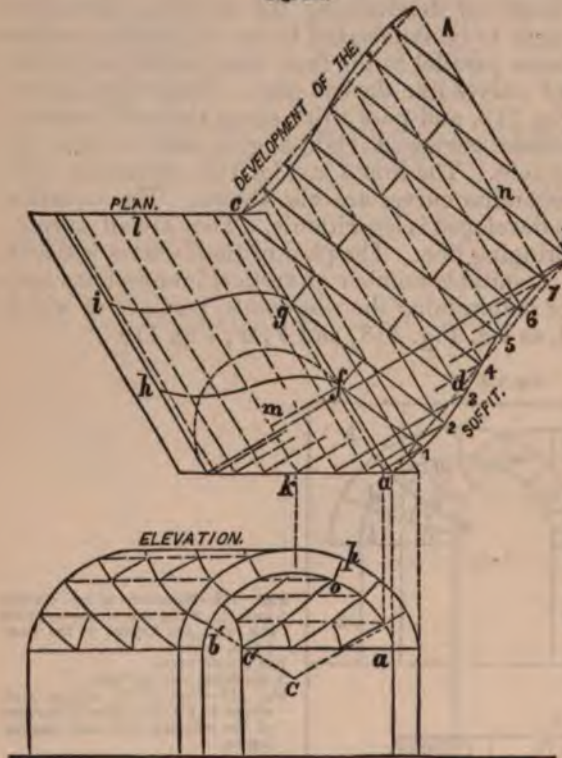

Fig. 120 is the plan of an oblique arch.

$l$  is the axis,  $a c$  the springing line,  $a k$  the face;  $a b$  and  $c A$  the development of the intrados of oblique section. The right section,  $m f$ , is the arc of a circle;  $A f$  and  $i g$  are horizontal projections of heading joints;  $f n$  is the development of the joint  $A f$ ,  $g 2$ ,  $c 3$ , etc., are the developments of coursing joints.

Fig. 121 is the elevation of an oblique arch, of which Fig. 120 is the plan.

$a c' o$  is the soffit.

$a c'$  is the springing line.

$c' o$ , spiral coursing joint.

$C$  is a point directly below the axis, from which all the joints, as  $p o$ , in the face radiate.

Fig. 121.

Fig. 121 is the elevation of such an oblique arch, and Fig. 120 is the plan. The system here shown is sometimes called "Buck's System." In order to construct this system graphically, we conceive that the soffit is developed, or rolled out about the springing line  $a c$ . Let  $m f$  be a right

section (which is here supposed to be circular). Conceive that it is revolved down to coincide with the horizontal plane, and that the circumference is divided into a convenient number of equal parts, and through the points of division conceive that cylindrical elements are drawn, as shown in the plan. In the development the circumference of the semicircle will become the line  $fb$ , and the cylindrical elements will be, as shown, parallel to the springing line  $ac$ . From the points where the horizontal projections of the cylindrical elements intersect the face  $ak$ , draw lines parallel to  $fb$ , and note their intersections with the developed position of the cylindrical elements, and the curve  $adb$  through these points will be the development of the intrados of oblique section. In a similar way find  $cA$ .

Join  $ab$  with a straight line, and divide it into as many equal parts as there are to be voussoirs in the face. In the figure there are eight such parts. When there is an even number there will be a joint at the crown, but when an odd number there will be the appearance of a keystone at the crown. From  $c$  at the end of the springing-line  $ac$  draw a perpendicular  $cd$  to the line  $ab$ , and if it passes through one of the divisions previously determined on  $ab$ , we proceed with the construction; but if it does not, we make such a change in the data as will make it perpendicular. This may be done in several ways. We may erect a perpendicular to  $ab$  from the joint which is nearest the foot of the perpendicular previously drawn, and note where it intersects the springing-line, and change the length of the arch so that it will pass through that point. Or we may change the obliquity of the arch, or change the number of divisions of the line  $ab$ . If the foot of the perpendicular should fall near a division, the line may be changed so as to pass through the point and leave it slightly out of a perpendicular. We might also disregard the condition that the perpendicular  $dc$  should pass through the end of the springing-line  $ac$ ; but this is objectionable, because the opposite sides of the arch would then not be alike.

Having fixed the position of  $cd$ , we proceed to draw lines through the several points of division of  $ab$ , parallel to  $cd$ . It should be observed that points through which these parallel lines are drawn are on the straight line  $adb$ , and not on the curved line  $a1, 2$ , etc. The parallel lines thus drawn are the *coursing joints*. The development of the *ring joints*  $fn$ , etc., are perpendicular to the developed coursing joints, and hence will be normal to each other in their true position in the

arch; and hence it is evident that the intrados in oblique section  $ab$  will not be perpendicular to the coursing joints. And since the projection of the face is a straight line,  $ak$ , it is evident that the horizontal projection of a ring joint will be a curved line  $fh$ , the position of which may be determined by reversing the process by which  $a12b$  was found. The horizontal projection of the coursing joints will also be curved lines.

This construction evidently makes the divisions  $a1-12-23$ , etc., on the curved line  $adb$ , unequal. The space  $a1$  on the development is laid off on the arc in the elevation from  $a$ . The space  $1-2$  is next laid off, and so on. By developing the extrados and determining the points of division on the back of the arch, we may construct the radial lines in the face of the arch. These lines are slightly curved in the arch, but it is found, by constructing the arch on a large scale, that the chords of the arcs  $op$ , etc., all pass through a common point  $C$ . The coursing joints and ring joints in the elevation are easily determined from the plan.

The bed-surfaces of the voussoirs may be generated by conceiving a radial line to pass through one corner of them (which will be normal to the soffit) and moved along on a coursing joint, keeping it constantly normal to the soffit. This line will generate a true helicoidal surface. The end surfaces of the voussoirs are generated in a similar way by moving a radial line along a ring joint, and hence these surfaces are also helicoidal. The lengths of the end voussoirs, measured on the back of the arch next to the oblique angles, will be shorter than those next to the acute angles, while all those in the body of the arch will be like each other.

Mr. Hart, an English author, proposed a method which differed from the one above explained in the following particulars: The spaces in the curved line  $adb$  were made equal to each other; the coursing joints were straight, and passed through the points of division at the opposite ends of the arch in the developed intrados; hence, the coursing joints in this system are not parallel to each other. Another distinction is, the ring joints and end-faces of all the voussoirs are parallel to the end of the arch, and hence the end-faces are plane. This might simplify the construction, but it does not use the material from which the voussoirs are cut as economically as the preceding system. In this system the bed-surfaces are helicoidal, as in the preceding system. The preceding system seems to be thoroughly scientific and quite as easily executed as the latter, or of any other conceivable system in which the

joints are spiral. In practice, *templets* and *bevels* are made, in order to guide the workmen in making the angles and surfaces of the voussoirs.

**569. Arched Bridges.** Cylindrical arches with any of the usual forms of curve of intrados may be used for bridges. The selection will be restricted by the width of the bay, the highest water-level during freshets, the approaches to the bridge, and the architectural effect which may be produced by the structure, as it is more or less exposed to view at the intermediate stages between high and low water.

Oval and segment arches are mostly preferred to the full centre arch, particularly for medium and wide bays, for the reasons that, for the same level of roadway, they afford a more ample water-way under them, and their heads and spandrels offer a smaller surface to the pressure of the water during freshets than the full centre arch under like circumstances.

The level of the springing lines will depend upon the rise of the arches, and the height of their crowns above the water-level of the highest freshets. The crown of the arches should not, as a general rule, be less than three feet above the highest known water-level, in order that a passage-way may be left for floating bodies descending during freshets. Between this, the lowest position of the crown, and any other, the rise should be so chosen that the approaches, on the one hand, may not be unnecessarily raised, nor, on the other, the springing lines be placed so low as to mar the architectural effect of the structure during the ordinary stages of the water.

When the arches are of the same size, the axis of the roadway and the principal architectural lines which run lengthwise along the heads of the bridge, as the top of the parapet, the cornice, etc., etc., will be horizontal, and the bridge, to use a common expression, be on a *dead level* throughout. This has for some time been a favorite feature in bridge architecture, few of the more recent and celebrated bridges being without it, as it is thought to give a character of lightness and boldness to the structure.

**570. Centres.** Before an arch is constructed a strong support or framework is erected to support the arch until the work is completed. This support is called *the centering of the arch*. It must be made strong, and so as to settle as little as possible while the masonry is being erected; and in arches of long span it must be so erected and supported that it may be removed without causing local or cross strains in the arch. To accomplish this, the centering should be removed from the entire soffit at the same time. It is espe-



cially detrimental to relieve one side whilst the other side is firmly supported.

571. **Means used for striking Centres.** When the arch is completed the centres are detached from it, or struck. To effect this in large centres an arrangement of wedge blocks is used, termed the *striking-plates*, by means of which the centre may be gradually lowered and separated from the soffit of the arch. This arrangement consists (Fig. 125) in forming steps upon the upper surface of the beam which forms the framed support to receive a wedge-shaped block, on which another beam, having its under surface also arranged with steps, rests. The struts of the rib either abut against the upper surface of the top beam, or else are inserted into cast-iron sockets, termed *shoe-plates*, fastened to this surface. The centre is struck by driving back the wedge block.

572. When the struts rest upon intermediate supports between the abutments, double or *folding* wedges may be placed under the struts, or else upon the back pieces of the ribs under each bolster. The latter arrangement presents the advantage of allowing any part of the centre to be eased from the soffit, instead of detaching the whole at once as in the other methods of striking wedges. This method was employed for the centres of Grosvenor Bridge (Fig. 124), over the river Dee at Chester, and was perfectly successful both in allowing a gradual settling of the arch at various points, and in the operation of striking.

573. A novel application of sand to the striking of centres has lately been made with success. Vessels containing the sand are placed on the supports for the centres, and are so arranged near the bottom that the sand can be allowed to run out slowly when the time comes for striking. The centres are placed on these vessels and keyed up in the usual way. To lower them, the sand is allowed to run out and let the centres gradually down. This method has the advantage of steadiness of lowering each rib of the centre, and of not allowing one to come down more rapidly than the others. After the sand has all run out, the centres can be taken down in the ordinary manner.

574. For small light arches (Fig. 122) the ribs may be formed of two or more thicknesses of short boards, firmly nailed together; the boards in each course abutting end to end by a joint in the direction of the radius of curvature of the arch, and breaking joints with those of the other course. The ribs are shaped to the form of the intrados of the arch,

to receive the bolsters, which are of battens cut to suitable lengths and nailed to the ribs.



Fig. 122—Represents the rib of a centre for light arches.  
*a, a*, rib formed of planks.  
*b, b*, bolster pieces which receive the masonry.

575. For heavy arches with wide spans, when firm intermediate points of support can be procured between the abutments, the back pieces (Fig. 123) may be supported by shores



Fig. 123—Represents the rib of a centre with intermediate points of support.  
*a*, back pieces of the rib which receive the bolsters *f*.  
*b, b*, struts which support the back pieces.  
*d, d*, braces.  
*c*, solid beam resting on the intermediate supports *d, d*, which receive the ends of the struts *b, b*.

placed under the blocks in the direction of the radii of curvature of the arch, or of inclined struts (Fig. 124) resting on the points of support. The shores, or struts, are prevented from bending by braces suitably placed for the purpose.

If intermediate points of support cannot be obtained, a broad framed support must be made at each abutment to receive the extremities of the struts that sustain the back pieces. The framed support (Fig. 125) consists of a heavy beam laid either horizontally or inclined, and is placed at that joint of the arch (the one which makes an angle of about  $30^\circ$  with the horizon) where the voussoirs, if unsupported beneath, would slide on their beds. This beam is borne by shores, which find firm points of support on the foundations of the abutment.

The back pieces of the centre (Fig. 125) may be supported by inclined struts, which rest immediately upon the framed support, one of the two struts under each block resting upon one of the framed supports, the other on the one on the oppo-



Fig. 124—Represents a part of the rib of Grosvenor Bridge over the Dee at Chester. Span 300 feet.

A, A, Intermediate points of support.

a, a, a, struts resting upon cast-iron sockets on the supports A.

b, b, two courses of plank each  $4\frac{1}{4}$  inches thick bent over the struts a, a, to the form of the arch, the courses breaking joints.

c, c, folding wedges laid upon the back pieces b of each rib to receive the bolsters on which the voussoirs are laid.

site side, the two struts being so placed as to make equal angles with the radius of curvature of the arch drawn through the middle point of the block. Bridle pieces, placed in the direction of the radius of curvature, embrace the blocks and struts in the usual manner, and prevent the latter from sagging. This combination presents a figure of invariable form, as the strain at any one point is received by the struts and transmitted directly to the fixed points of support. It has the disadvantage of requiring beams of great length when the span of the arch is considerable, and of presenting frequent crossing of the struts where notches will be requisite, and the strength of the beams thereby diminished.

The centre of Waterloo Bridge, over the Thames (Fig. 125), was framed on this principle. To avoid the inconveniences resulting from the crossing of the struts, and of building beams of sufficient length where the struts could not be procured from a single beam, the device was adopted of receiving the ends of several struts at the points of crossing into a large cast-iron socket suspended by a bridle piece.

576. When the preceding combination cannot be employed, a strong truss (Fig. 126), consisting of two inclined struts, resting upon the framed supports, and abutting at top against a straining beam, may be formed to receive the ends of some

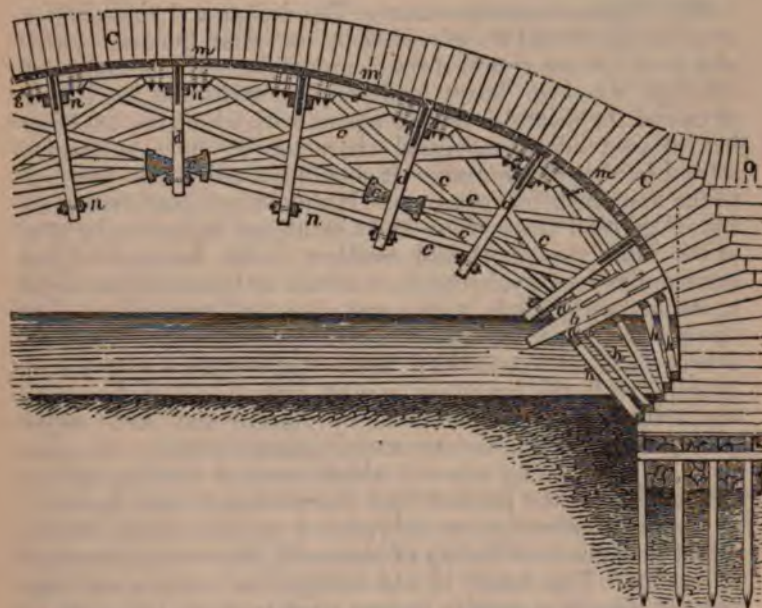

Fig. 125—Represents a part of a rib of Waterloo Bridge over the Thames.

*a, a, b*, three heavy beams, forming the *striking plates*, which with the shores *h, h*, form the framed support for the struts of the centre.  
*c, c*, struts abutting against the blocks *g, g* placed under the joints of the back pieces *f, f*.  
*d, d*, bridle or radial pieces in pairs which are confined at top and bottom between the horizontal ties *n, n* of the ribs, also in pairs.  
*s, s*, cast-iron sockets.  
*m, m*, bolsters of the centre resting on the back pieces *f*.



Fig. 126—Represents a frame for a rib in which the two inclined struts *b, b* and the straining beams *c, c* form intermediate supports for some of the struts that support the back pieces *a, a*. *e, e* and *d* are the framed extreme supports

of the struts which support the back pieces. This combination, and all of a like character, require that the arch should not be constructed more rapidly on one side of the centre than on the other, as any inequality of strain on the two halves of the centre would have a tendency to change the shape of the frame, thrusting it in the direction of the greater strain.

**577. Style of Architecture.** The design and construction of a bridge should be governed by the same general principles as any other architectural composition. As the object of a bridge is to bear heavy loads, and to withstand the effects of one of the most destructive agents with which the engineer has to contend, the general character of its architecture should be that of strength. It should not only be secure, but to the apprehension appear so. It should be equally removed from Egyptian massiveness and Corinthian lightness; while, at the same time, it should conform to the features of the surrounding locality, being more ornate and carefully wrought in its minor details in a city, and near buildings of a sumptuous style, than in more obscure quarters; and assuming every shade of conformity, from that which would be in keeping with the humblest hamlet and tamest landscape to the boldest features presented by Nature and Art. Simplicity and strength are its natural characteristics; all ornament of detail being rejected which is not of obvious utility, and suitable to the point of view from which it must be seen; as well as all attempts at boldness of general design which might give rise to a feeling of insecurity, however unfounded in reality. The heads of the bridge, the cornice, and the parapet should generally present an unbroken outline; this, however, may be departed from in bridges where it is desirable to place recesses for seats, so as not to interfere with the footpaths; in which case a plain buttress may be built above each starting to support the recess and its seats, the utility of which will be obvious, while it will give an appearance of additional strength when the height of the parapet above the startings is at all considerable.

**578. Construction.** The methods of laying the foundations of structures of stone, &c., described under the article of Masonry, are alike applicable to all structures which come under this denomination.

**579.** Various expedients have been tried to secure the bed of the natural water-way around and between the piers; among the most simple and efficacious of which is that of covering the surface to be protected by a bed of stone broken into fragments of sufficient bulk to resist the velocity of the current in the bays, if the soil is of an ordinary clayey mud; but, if it be of loose sand or gravel, the surface should be first covered by a bed of tenacious clay before the stone be thrown in. The voids between the blocks of stone, in time, become filled with a deposit of mud, which, acting as a cement, gives to the mass a character of great durability.

580. The foundation courses of the piers should be formed of heavy blocks of cut stone bonded in the most careful manner, and carried up in offsets. The faces of the piers should be of cut stone well bonded. They may be built either vertically, or with a slight batter. Their thickness at the impost should be greater than what would be deemed sufficient under ordinary circumstances; as they are exposed to the destructive action of the current, and of shocks from heavy floating bodies; and from the loss of weight of the parts immersed, owing to the buoyant effort of the water, their resistance is decreased. The most successful bridge architects have adopted the practice of making the thickness of the piers at the impost between one sixth and one eighth of the span of the arch. The thickness of the piers of the bridge of Neuilly, near Paris, built by the celebrated Perronet, whose works form an epoch in modern bridge architecture, is only one ninth of the span, its arches also being remarkable for the boldness of their curve.

581. The usual practice is to give to all the piers the same proportional thickness. It has, however, been recommended by some engineers to give sufficient thickness to a few of the piers to resist the horizontal thrust of the arches on either side of them, and thus secure a part of the structure from ruin, should an accident happen to any of the other piers. These masses, to which the name *abutment piers* has been applied, would be objectionable from the diminution of the natural water-way that would be caused by their bulk, and from the additional cost for their construction, besides impairing the architectural effect of the structure. They present the advantage, in addition to their main object, of permitting the bridge to be constructed by sections, and thus procure an economy in the cost of the wooden centres for the arches.

582. The projection of the starlings beyond the heads of the bridge, their form, and the height given to them above the springing lines, will depend upon local circumstances. As the main objects of the starlings are to form a *fender* or *guard* to secure the masonry of the spandrels, &c., from being damaged by floating bodies, and to serve as a cut-water to turn the current aside, and prevent the formation of whirls, and their action on the bed around the foundations, the form given to them should subserve both these purposes. Of the different forms of horizontal section which have been given to starlings (Figs. 127, 128, 129, 130), the semi-ellipse, from experiments carefully made, with these ends in view, appears best to satisfy both objects.

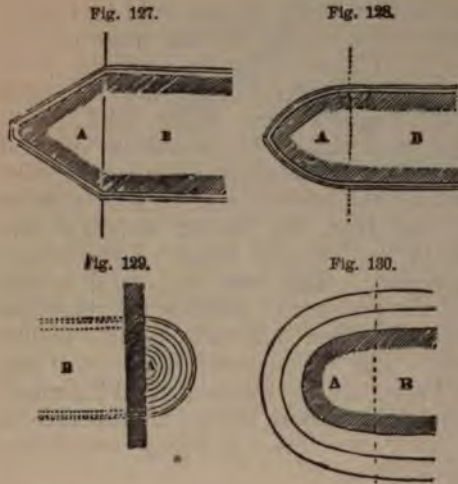

Figs. 127, 128, and 129—Represent horizontal sections of starlings A of the more usual forms, and part of the pier B above the foundation courses. Fig. 130 represents the plan of the hood of a starling laid in courses, the general shape being that of the quarter of a sphere.

The up and down stream starlings, in tidal rivers not subject to freshets and ice, usually receive the same projections, which, when their plan is a semi-ellipse, must be somewhat greater than the semi-width of the pier. Their general vertical outline is columnar, being either straight or swelled (Figs. 131, 132, 133, 134). They should be built as high as the ordi-

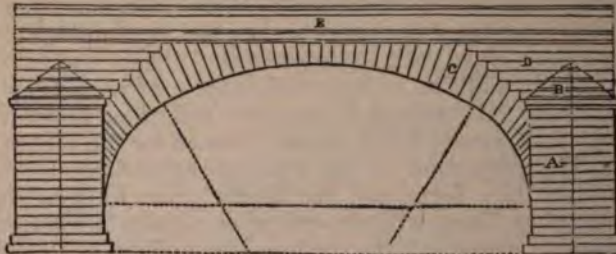

Fig. 131—Represents in elevation starlings A, their hoods B, the voussoirs C, the spandrels D, and the combination of their courses and joints with each other in an oval arch of three centres. E, parapet; F, cornice.

nary highest water-level. They are finished at top with a coping stone to preserve the masonry from the action of rain, &c.: this stone, termed the *hood*, may receive a conical, a spheroidal, or any other shape which will subserve the object in view, and produce a pleasing architectural effect, in keeping with the locality.



Fig. 132—Represents in elevation the combinations of the same elements as in Fig. 131 for a flat segmental arch.

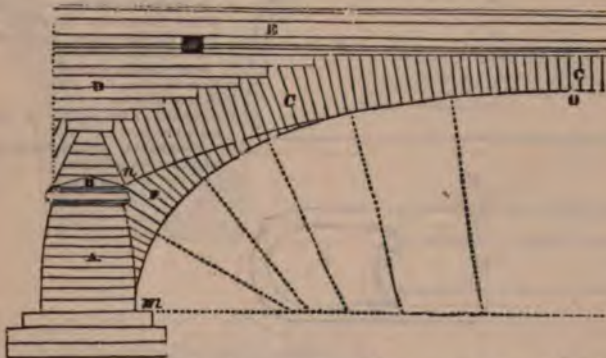

Fig. 133—Represents in elevation the combinations of the same elements as in Fig. 132, from the bridge of Neuilly, and oval of eleven centres.  
*om*, curve of intrados.  
*on*, arc of circle traced on the head of the bridge.



Fig. 134—Represents a cross section and elevation through the crown of Fig. 132, showing the arrangement also of the roadway, footpaths, parapet, and cornice.



In streams subject to freshets and ice, the up-stream starlings should receive a greater projection than those down stream, and, moreover, be built in the form of an inclined plane (Fig. 135) to facilitate the breaking of the ice, and its passage through the arches.

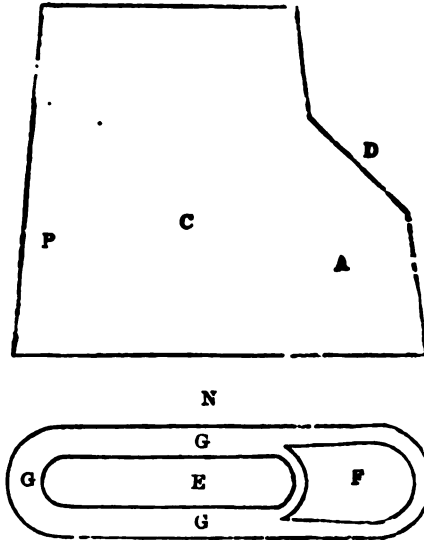

Fig. 135—Represents a side elevation and plan N of a pier of the Potomac aqueduct, arranged with an ice-breaker starling.

- A, up-stream starling, with the inclined ice-breaker D, which rises from the low-water level above that of the highest freshets.
- B, down-stream starling.
- C, face of pier.
- E, top of pier.
- F, horizontal projection of top of ice breaker.
- GG, horizontal projection of faces of pier and starlings.

583. Where the banks of a water-course spanned by a bridge are so steep and difficult of access that the roadway must be raised to the same level with their crests, security for the foundation, and economy in the construction demand that *hollow or open piers* be used instead of a solid mass of masonry. A construction of this kind requires great precaution. The facing courses of the piers must be of heavy blocks dressed with extreme accuracy. The starlings must be built solid. The faces must be connected by one or more cross tie-walls of heavy, well-bonded blocks; the tie-walls being connected from distance to distance vertically by strong tie-blocks; or, if the width of the pier be considerable, by a tie-wall along its centre line.

584. The foundations, the dimensions, and the form of the abutments of a bridge will be regulated upon the same principles as the like parts of other arched structures; a judicious conformity to the character of strength demanded by the

structure, and to the requirements of the locality, being observed. The walls which at the extremities of the bridge form the continuation of the heads, and sustain the embankments of the approaches,—and which, from their widening out from the general line of the heads, so as to form a gradual contraction of the avenue by which the bridge is approached, are termed the *wing-walls*,—serve as firm buttresses to the abutments. In some cases the back of the abutment is terminated by a cylindrical arch (Fig. 136) placed on end, or having its right-line elements vertical, which connects the



Fig. 136—Represents a horizontal section of an abutment A, with curved wing-walls B, B, connected with a central buttress C, and a cross tie-wall D.



Fig. 137—Represents a horizontal section of an abutment A, with straight wing-walls B, B, terminated by return-walls C, C, D, central buttress.

two wing-walls. In others (Fig. 137) a rectangular-shaped buttress is built back from the centre line of the abutment, and is connected with the wing-walls either by horizontal arches, or by a vertical cross tie-wall.

585. The wing-walls may be either plane surface walls (Fig. 138) arranged to make a given angle with the heads of the bridge, or they may be curved surface-walls presenting their concavity (Fig. 145) or their convexity to the exterior; or of any other shape, whether presenting a continuous or a broken surface, that the locality may demand.

588. The arches of bridges demand great care in propor-

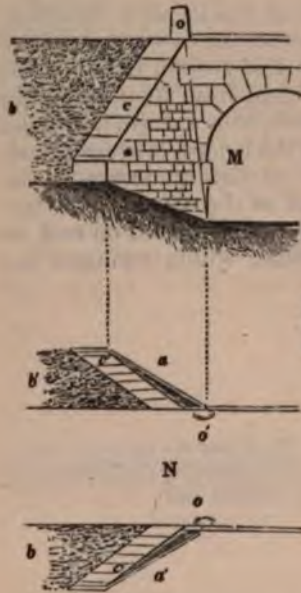

Fig. 138—Represents an elevation M and plan N of a portion of a single arch bridge with straight wing-walls sustaining an embankment across the valley of the water-course.

*a, a'*, face of wing-wall.  
*b, b'*, side slope of embankment.  
*c, c'*, top of wing-wall.  
*o, o'*, fender or guard stones.

tioning the dimensions of the voussoirs, and procuring accuracy in their forms, as the strength of the structure, and the permanence of its figure, will depend chiefly upon the attention bestowed on these points. Peculiar care should be given in arranging the masonry above the piers which lies between the two adjacent arches. In some of the more recent bridges, (Fig. 139,) this part is built up solid but a short distance above the imposts, generally not higher than a fourth of the rise, and is finished with a reversed arch to give greater security against the effects of the pressure thrown upon it.

The backs of the arches should be covered with a watertight capping of beton, and a coating of asphaltum.

587. The entire spandrel courses of the heads are usually not laid until the arches have been uncentred, and have settled, in order that the joints of these courses may not be subject to any other cause of displacement than what may arise from the effects of variations of temperature upon the arches. The thickness of the head-walls will depend upon the method adopted for supporting the roadway. If this be by a filling of earth between the head-walls, then their thickness must be calculated not only to resist the pressure of the earth which they sustain, but allowance must also be made for the

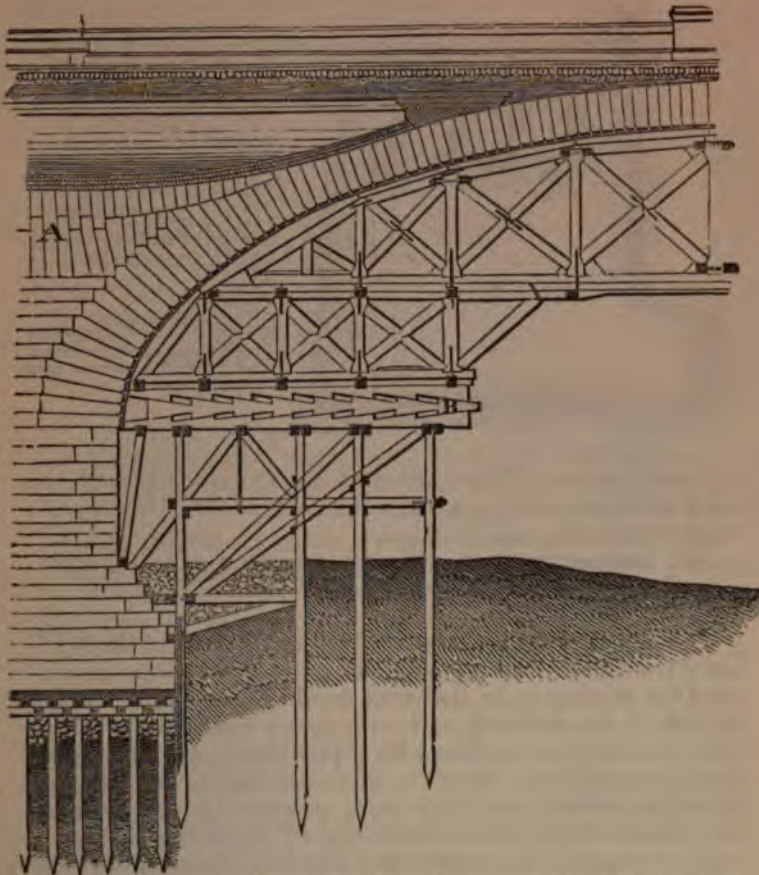

Fig. 139—Represents a longitudinal section of a portion of a pier and foundations, and of an arch and its centre of the new London bridge over the Thames.

- A, finish of solid spandrel with reversed arch.  
 B, wedge of striking plates.  
 C, recess over the starlings for seats.

effects of the shocks of floating bodies in weakening the bond, and separating the blocks from their mortar-bed. The more approved methods of supporting the roadway, except for very flat segment arches, are to lay the road materials either upon broad flagging stones (Figs. 139, 140,) which rest upon thin brick walls built parallel to the head-walls, and supported by the piers and arches; or by small arches, (Fig 141) for which these walls serve as piers; or by a system of small groined arches supported by pillars resting upon the piers

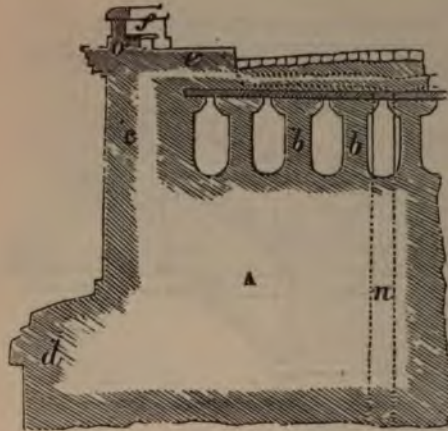

Fig. 140—Represents a profile of Fig. 139 through the centre of the pier, showing the arrangement of the roadway and its drainage, &c.

- A, section of masonry of pier and spandrel.
- b, b, sections of walls parallel to head-wall, which support the flagging stone on which the roadway is laid.
- c, section of head-wall and buttress above the starting d.
- e, footpath.
- f, recess for seats over the buttress.
- g, cornice and parapet.
- n, vertical conduit in the pier communicating with two others under the roadway from the side channels.

and main arches. When either of these methods is used, the head-walls may receive a mean thickness of one fifth of their height above the solid spandrel.

588. **Superstructure.** The superstructure of a bridge consists of a cornice, the roadway and footpaths, &c., and a parapet.

The object of the cornice is to shelter the face of the head-walls from rain. To subserve this purpose, its projection beyond the surface to be sheltered should be the greater as the altitude of the sheltered part is the more considerable. This rule will require a cornice with supporting blocks, (Fig. 142,) termed *modillions*, below it, whenever the projecting part would be actually, or might seem, insecure from its weight. The height of the cornice, including its supports, should generally be equal to its projections; this will often require more or less of detail in the profile of the cornice, in order that it may not appear heavy. The top surface of the cornice should be a little above that of the footpath, or roadway, and be slightly sloped outward; the bottom should be arranged with a suitable *larmier*, or *drip*, to prevent the water from finding a passage along its under surface to the face of the wall.

589. The parapet surmounts the cornice, and should be high enough to secure vehicles and foot-passengers from accidents, without however intercepting the view from the bridge. The parapet is usually a plain low wall of cut stone, surmounted by a coping slightly rounded on its top surface. In bridges which have a character of lightness, like those with flat segment arches, the parapet may consist of alternate panels of

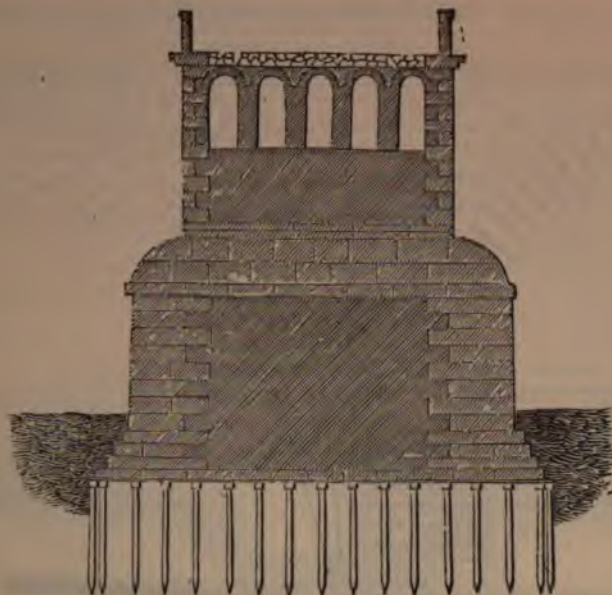

Fig. 141—Represents a section through the axis of a pier of bridge built of stone with brick filling, showing the arrangement for supporting the roadway on small arches.



Fig. 142—Represents a section through the crown of an arch, showing the cornice *a*, modillion *b*, parapet *c*, and footpath *d*.  
A, key-stones.  
B, side elevation of soffit.

plain wall and balustrades, provided this arrangement be otherwise in keeping with the locality. The exterior face of the parapet should not project beyond that of the heads. The blocks of which it is formed, and particularly those of the coping, should be firmly secured with copper or iron cramps.

590. Strong and durable stone, dressed with the chisel, or hammer, should alone be used for the masonry of bridges where the span of the arch exceeds fifty feet. The interior of

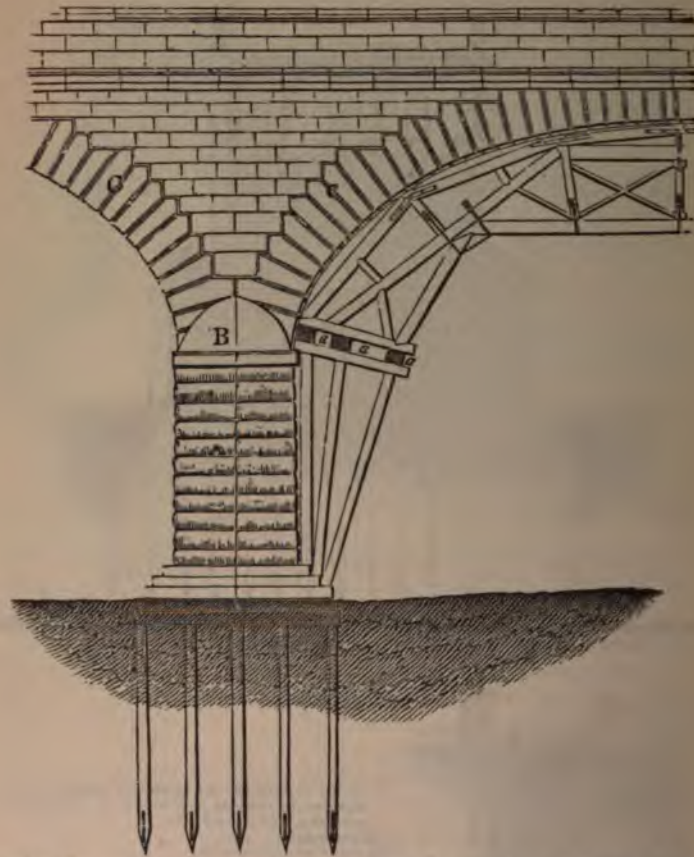

Fig. 143—Represents an elevation of a pier, a portion of two arches, and the centre of the bridge of which Fig. 141 is the section.

A, face of starling.  
 B, hood.  
 C, voussoirs with chamfered joints.

the piers, and the backing of the abutments and head-walls, may, for economy, be of good rubble, provided great attention be bestowed upon the bond and workmanship. For medium and small spans a mixed masonry of dressed stone and rubble, or brick, may be used; and, in some cases, brick alone. In all these cases (Figs. 141, 143) the starlings,—the foundation courses,—the impost stone,—the ring courses, at least of the heads,—and the key-stone, should be of good dressed stone. The remainder may be of coursed rubble, or of the best brick,

for the facing, with good rubble or brick for the fillings and backings. In a mixed masonry of this character the courses of dressed stone may project slightly beyond the surfaces of the rest of the structure. The architectural effect of this arrangement is in some degree pleasing, particularly when the joints are chamfered; and the method is obviously useful in structures of this kind, as protection is afforded by it to the surfaces which, from the nature of the material, or the character of the work, offer the least resistance to the destructive action of floating bodies. Hydraulic mortar should alone be used in every part of the masonry of bridges.

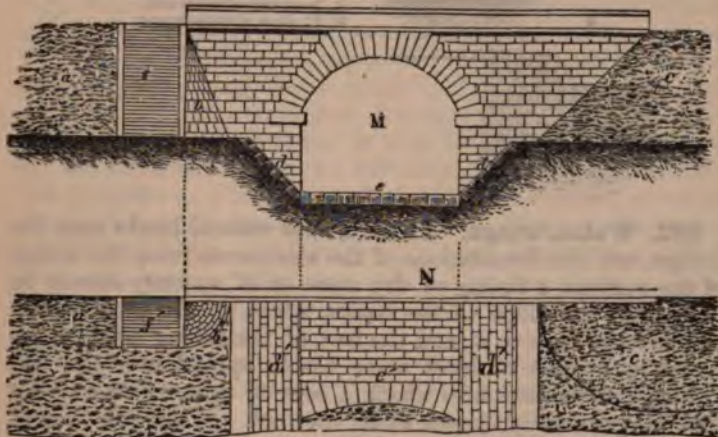

Fig. 144—Elevation M and plan N, showing the manner of arranging the embankments of the approaches, when the head-walls of the bridge are simply prolonged.

- a, a'*, side slope of embankment,  
*b, b'*, dry stone facing of the embankment where its end is rounded off, forming a quarter of a cone finish.  
*f, f'*, flight of steps for foot-passengers to ascend the embankment.  
*c, c'*, embankment arranged as above, but simply sodded.  
*d, d'*, facing of dry stone for the side slopes of the banks.  
*e, e'*, facing of the bottom of the stream.

**591. Approaches.** The approaches should be so made as to procure an easy and safe access to the bridge, and not obstruct unnecessarily other channels of communication.

When several avenues meet at a bridge, or where the width of the roadway of a direct avenue is greater than that of the bridge, the approaches are made by gradually widening the outlet from the bridge, until it attains the requisite width, by means of wing-walls of any of the usual forms that may



suit the locality. The form of wing-wall (Fig. 145) presenting a concave surface outward is usually preferred when suited to the locality, both for its architectural effect and its strength. When made of dressed stone it is of more difficult construction and more expensive than the plane surface wall.

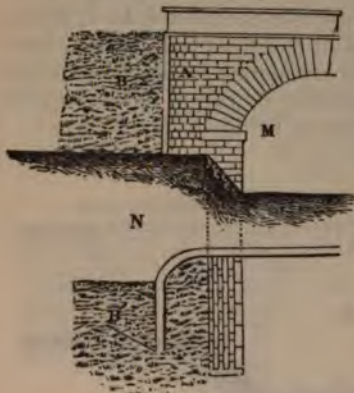

Fig. 145—Represents an elevation M and plan N of a curved face wing-wall.  
A, front view of wing-wall.  
B, B', slope of embankment.

**592. Water-wings.** To secure the natural banks near the bridge, and the foundations of the abutments from the action of the current, a facing of dry stone or of masonry should be laid upon the slope of the banks, which should be properly prepared to receive it, and the foot of the facing must be secured by a mass of loose stone blocks spread over the bed around it, in addition to which a line of square-jointed piles may be previously driven along the foot. When the face of the abutment projects beyond the natural banks, an embankment faced with stone should be formed, connecting the face with points on the natural banks above and below the bridge. By this arrangement, termed the *water-wings*, the natural water-way will be gradually contracted to conform to that left by the bridge.

**593. Enlargement of Water-way.** In the full centre and oval arches, when the springing lines are placed low, the spandrels present a considerable surface and obstruction to the current during the higher stages of the water. This not only endangers the safety of the bridge, by the accumulation of drift-wood and ice which it occasions, but, during these epochs, gives a heavy appearance to the structure. To remedy these defects the solid angle, formed by the heads and the soffit of the arch, may be truncated, the base of the cuneiform-shaped mass taken away being near the springing lines

of the arch, and its apex near the crown. The form of the detached mass may be variously arranged. In the bridge of Neuilly, which is one of the first where this expedient was resorted to, the surface, marked F, (Figs. 133, 134) left by detaching the mass in question, is warped, and lies between two plane curves, the one an arc of a circle  $no$ , traced on the head of the bridge, the other an oval,  $mop$ , traced on the soffit of the arch. This affords a funnel-shaped water-way to each arch, and, during high water, gives a light appearance to the structure, as the voussoirs of the head ring-course have then the appearance of belonging to a flat segmental arch.

**594. General Remarks.** The architecture of stone bridges has, within a somewhat recent period, been carried to a very high degree of perfection, both in design and in mechanical execution. France, in this respect, has given an example to the world, and has found worthy rivals in the rest of Europe, and particularly in Great Britain. Her territory is dotted over with innumerable fine monuments of this character, which attest her solicitude as well for the public welfare as for the advancement of the industrial and liberal arts. For her progress in this branch of architecture, France is mainly indebted to her School and her Corps of *Ponts et Chaussées*; institutions which, from the time of her celebrated engineer Perronet, have supplied her with a long line of names, alike eminent in the sciences and arts which pertain to the profession of the engineer.

England, although on some points of mechanical skill pertaining to the engineer's art the superior of France, holds the second rank to her in the *science* of her engineers. Without establishments for professional training corresponding to those of France, the English engineers, as a body, have, until within a few years, labored under the disadvantage of having none of those institutions which, by creating a common bond of union, serve not only to diffuse science throughout the whole body, but to raise merit to its proper level, and frown down alike, through an enlightened *esprit de corps*, the assumptions of ignorant pretension, and the malevolence of petty jealousies.

Among the works of this class, in this country, may be cited the railroad bridge, called the *Thomas Viaduct*, over the Patapsco, on the line of the Baltimore and Washington railroad, designed and built by Mr. B. H. Latrobe, the engineer of the road. This is one of the few existing bridge structures with a curved axis. The engineer has very happily met the double difficulty before him, of being obliged

to adopt a curved axis, and of the want of workmen sufficiently conversant with the application of working drawings of a rather complicated character, by placing full centre cylindrical arches upon piers with a trapezoidal horizontal section. This structure, with the exception of some minor details in rather questionable taste, as the slight iron parapet railing, for example, presents an imposing aspect, and does great credit to the intelligence and skill of the engineer at the time of its construction, but recently launched in a new career. The fine single arch, known as the *Carrolton Viaduct*, on the Baltimore and Ohio railroad, is also highly creditable to the science and skill of the engineer and mechanics under whom it was raised. One of the largest bridges in the United States, designed and partly executed in stone, is the *Potomac Aqueduct* at Georgetown, where the Chesapeake and Ohio canal intersects the Potomac river. This work, to which a wooden superstructure has been made, was built under the superintendence of Captain Turnbull of the U. S. Topographical Engineers.

595. The following table contains a summary of the principal details of some of the more noted stone bridges of Europe:

NAME OF BRIDGE.	River.	Form of Arch.	Number of arches.	Span of widest span.	Rise.	Depth of key-stone.	Width between the heads.	Date.	Name of Engineer.
Vieille-Brionde	Allier.	Segment.	1	178	69	5.3	..	1454	Grenier & Estone
Rialto .....	.....	"	1	98.6	23	..	..	1578	Michel Angelo,
Claix .....	Drac.	"	1	150	54	3.1	..	1611	.....
Neuilly .....	Seine.	Elliptical.	5	127.9	31.9	5.3	47.9	1774	Perronet.
Lavaur .....	Agout.	"	1	160.5	65	10.9	..	1775	Saget.
Saint-Maxence	Oise.	Segment.	3	75.7	6	5	41.5	1784	Perronet.
Gignac .....	Erault.	Elliptical.	1	160	44	6.5	..	1793	Garipuy.
Jena .....	Seine.	Segment.	5	91.8	10.8	4.6	43.7	1811	Lamadé.
Rouen .....	Seine.	"	5	101.7	13.7	4.6	49.2	1813	Lamadé.
Waterloo .....	Thames.	Elliptical.	9	120	35	4.9	45	1816	Rennie.
Gloucester .....	Severn.	"	1	150	54	4.5	35	1827	Telford.
London .....	Thames.	"	5	152	37.8	5	56	1831	Rennie.
Turin .....	Dora Riparia.	Segment.	1	147.6	18	4.9	40	1833	Mosca.
Grosvenor .....	Dee.	"	1	200	42	4	..	1833	Hartley.

596. Among the recent French bridges, presenting some interesting features in their construction, may be cited that of *Souillac* over the Dordogne. The river at this place having a torrent-like character, and the bed being of lime-stone rock with a very uneven surface, and occasional deep fissures filled with sand and gravel, the obstacle to using either the caisson, or the ordinary coffer-dam for the foundations, was very great. The engineer, M. Vicat, so well known by his

researches upon mortar, etc., devised, to obviate these difficulties, the plan of enclosing the area of each pier by a coffer-work accurately fitted to the surface of the bed, and of filling this with beton to form a bed for the foundation courses. This he effected, by first forming a framework of heavy timber, so arranged that thick sheeting-piles could be driven close to the bottom, between its horizontal pieces, and form a well-jointed vessel to contain the semi-fluid material for the bed. After this coffer-work was placed, the loose sand and gravel was scooped from the bottom, the asperities of the surface levelled, and the fissures were voided, and refilled with fragments of a soft stone, which it was found could be more compactly settled, by ramming, in the fissures, than a looser and rounder material like gravel. On this prepared surface, the bed of beton, which was from 12 to 15 feet in thickness, was gradually raised, by successive layers, to within a few feet of the low-water level, and the stone superstructure then laid upon it, by using an ordinary coffer-dam that rested on the framework around the bed. In this bridge, as in that of Bordeaux, a provisional trial-weight, greater than the permanent load, was laid upon the bed, before commencing the superstructure.

To give greater security to foundations, they may be surrounded with a mass of loose stone blocks thrown in and allowed to find their own bed. Where piles are used and project some height above the bottom, besides the loose stone, a grating of heavy timber, placed between and enclosing the piling, may be used to give it greater stiffness and prevent outward spreading. In streams of a torrent character, where the bed is liable to be worn away, or shifted, an artificial covering, or apron of stone laid in mortar, has, in some cases, been used, both under the arches and above and below the bridge, as far as the bed seemed to require this protection. At the bridge of Bordeaux loose stone was spread over the river-bed between the piers, and it has been found to answer perfectly the object of the engineer, the blocks having, in a few years, become united into a firm mass by the clayey sediment of the river deposited in their interstices. At the elegant cast-iron bridge, built over the *Lary*, near Plymouth, resort was had to a similar plan for securing the bed, which is of shifting sand. The engineer, Mr. Rendel, here laid, in the first place, a bed of compact clay upon the sand bed between the piers, and imbedded in it loose stone. This method, which for its economy is worthy of note, has fully answered the expectations of the engineer.

## III.

## WOODEN BRIDGES.

597. **Abutments.** The abutments and piers of wooden bridges may be either of stone or of timber. Stone supports are preferable to those of timber, both on account of the superior durability of stone, and of its offering more security than frames of timber against the accidents to which the piers of bridges are liable from freshets, ice, &c.

598. Wooden abutments may be formed by constructing what is termed a *crib-work*, which consists of large pieces of square timber laid horizontally upon each other, to form the upright or sloping faces of the abutment. These pieces are halved into each other at the angles, and are otherwise firmly connected together by diagonal ties and iron bolts. The space enclosed by the crib-work, which is usually built up in the manner just described, only on three sides, is filled with earth carefully rammed, or with dry stone, as circumstances may seem to require.

A wooden abutment of a more economical construction may be made, by partly imbedding large beams of timber placed in a vertical or an inclined position, at intervals of a few feet from each other, and forming a facing of thick plank to sustain the earth behind the abutment. Wooden piers may also be made according to either of the methods here laid down, and be filled with loose stone, to give them sufficient stability to resist the forces to which they may be exposed; but the method is clumsy, and inferior, under every point of view, to stone piers, or to the methods which are about to be explained.

599. The simplest arrangement of a wooden pier consists (Fig. 146) in driving heavy square or round piles in a single row, placing them from two to four feet apart. These upright pieces are sawed off level, and connected at top by a horizontal beam, termed a *cap*, which is either mortised to receive a tenon made in each upright, or else is fastened to the uprights by bolts or pins. Other pieces, which are notched and bolted in pairs on the sides of the uprights, are placed in an inclined or diagonal position, to brace the whole system firmly. The several uprights of the pier are placed in the direction of the thread of the current. If thought necessary, two horizontal beams, arranged like the diagonal pieces, may be added to the system just below the lowest water-level. In a pier of this kind, the place of the starlings is supplied by two in-

clined beams on the same line with the uprights, which are termed *fender-beams*.

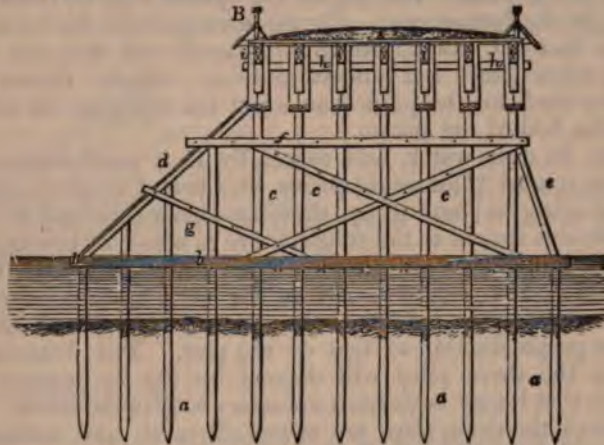

Fig. 146—Elevation of a wooden pier.  
*a, a*, piles of substructure.  
*b, b*, capping of piles arranged to receive the ends of the uprights *c, c*, which support the string-pieces *f, f*.  
*d*, upper fender beam.  
*e*, lower fender beam.  
*f, f*, horizontal ties bolted in pairs on the uprights.  
*g, g*, diagonal braces bolted in pairs on the uprights.  
*h, h*, capping of the uprights placed under the string pieces.  
*A*, roadway.  
*B*, parapet.

600. A strong objection to the system just described, arises from the difficulty of replacing the uprights when in a state of decay. To remedy this defect, it has been proposed to

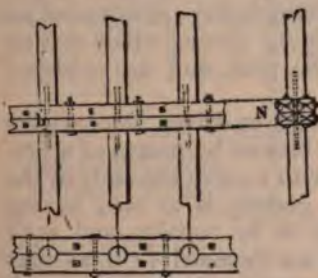

Fig. 147—Plan O, elevation M, and cross section N, showing the arrangement of the capping of the foundation piles with the uprights.  
*a*, piles.  
*b*, capping of four beams bolted together.  
*c*, uprights.

drive large piles in the positions to be occupied by the uprights (Fig. 147), to connect these piles below the low-water level by four horizontal beams, firmly fastened to the heads of the piles, which are sawed off at a proper height to receive the

horizontal beams. The two top beams have large square mortises to receive the ends of the uprights, which rest on those of the piles. The rest of the system may be constructed as in the former case. By this arrangement the uprights, when decayed, can be readily replaced, and they rest on a solid substructure not subject to decay; shorter timber also can be used for the piers than when the uprights are driven into the bed of the stream.

601. In deep water, and especially in a rapid current, a single row of piles might prove insufficient to give stability to the uprights; and it has therefore been proposed to give a sufficient spread to the substructure to admit of bracing the uprights by struts on the two sides. To effect this, three piles (Fig. 148) should be driven for each upright; one just under its position, and the other two on each side of this, on a line perpendicular to that of the pier. The distance between the three piles will depend on the inclination and length that it may be deemed necessary to give the struts. The heads of the three piles are sawed off level, and connected by two horizontal clamping pieces below the lowest water.

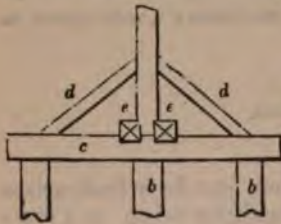

Fig. 148—Elevation of the arrangement of a wide foundation for a wooden pier.

a, upright.  
b, b, piles of the foundation.  
c, c, capping of the piles.  
d, d, struts to strengthen the uprights.  
e, e, clamping pieces bolted in pairs on the uprights.

A square mortise is left in these two pieces, over the middle pile, to receive the uprights. The uprights are fastened together at the bottom by two clamping pieces, which rest on those that clamp the heads of the piles, and are rendered firmer by the two struts.

602. In localities where piles cannot be driven, the uprights of the piers may be secured to the bottom by means of a grating, arranged in a suitable manner to receive the ends of the uprights. The bed, on which the grating is to rest, having been suitably prepared, it is floated to its position, and sunk either before or after the uprights are fastened to it, as may be found most convenient. The grating is retained in its place by loose stone. As a farther security for the piers, the uprights may be covered by a sheathing of boards, and the spaces between the sheathing be filled in with gravel.

603. As wooden piers are not of a suitable form to resist

heavy shocks, ice-breakers should be placed in the stream, opposite to each pier, and at some distance from it. In streams with a gentle current, a simple inclined beam (Fig. 149) covered with thick sheet-iron, and supported by uprights



Fig. 149—Elevation M and plan N of a simple ice-breaker.  
 a, a, foundation piles.  
 b, b, capping of piles.  
 c, c, uprights.  
 d, inclined fender-beam shod with iron.

and diagonal pieces, will be all that is necessary for an ice-breaker. But in rapid currents a crib-work, having the form of a triangular pyramid (Fig. 150), the up-stream edge of

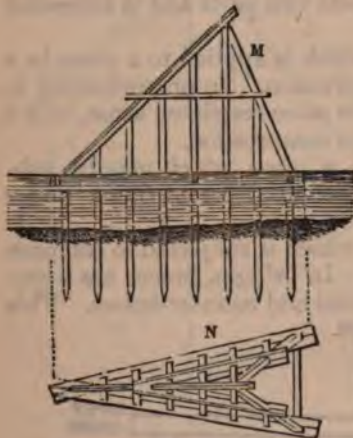

Fig. 150—Elevation M and plan N of the frame of an ice-breaker to be filled in with broken stone.

which is covered with iron, will be required, to offer sufficient resistance to shocks. The crib-work may be filled in, if it be deemed advisable, with blocks of stone.

604. In determining the length of the span the engineer must take into consideration the fact that wooden bridges require more frequent repairs than those of stone, arising



from the decay of the material, and from the effects of shrinking and vibrations upon the joints of the frames, and that the difficulty of replacing decayed parts, and readjusting the framework, increases rapidly with the span.

605. Bridge-frames may be divided into two general classes. To the one belong all those combinations, whether of straight or of curved timber, that exert a lateral pressure upon the abutments and piers, and in which the superstructure is generally above the bridge-frame. To the other, those combinations which exert no lateral pressure upon the points of support, and in which the roadway, &c., may be said to be suspended from the bridge-frame.

606. Definitions of some of the terms employed in bridge nomenclature.

A *Chord* is the upper or lower member in a *truss*. It extends from end to end of the structure. There are usually two chords, an upper and a lower chord. These may be parallel, as in Figs. 157 and 167, or the upper one may be curved (arched) and the lower one horizontal, or both may be curved. These pieces by some English writers are called *booms*, and by others *stringers*. The lower chord is often called a *tie*. The upper chord is sometimes called a *straining beam*.

A *Tie* is a piece which connects two parts and is subjected to tension.

A *Strut* is a general term which is applied to a piece in a truss which is subjected to compression. In proportioning it, it is treated as a *pillar*. In its more restricted sense, it is a *short* piece which is subjected to compression.

A *Tie-Strut*, or *Strut-Tie*, is a piece which may be subjected to tension and compression at different times, under different conditions of loading.

A *Brace* is an inclined piece which is subjected to compression. It is an inclined *strut*. In bridges, braces are sometimes distinguished as *main-braces* and *counter-braces*. This

Fig. 151.

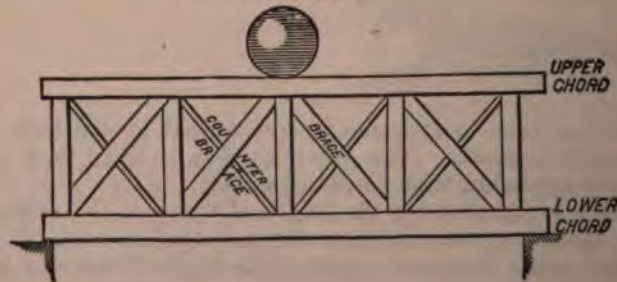

distinction is quite unnecessary in an analytical point of view, as will be seen hereafter, but it is so common in practice that it will not do to ignore it.

A *Main-Brace* is a brace which inclines from the end of a truss towards the centre, as in Fig. 151.

A *Counter-Brace* is one which inclines from the centre and towards the ends. In the same panel the counter-brace inclines the opposite way from the main-brace. See Fig. 151.

A *Tie-Brace* performs the office of both main and counter-brace; it is the same as a *Tie-Strut*.

**607. Long's Truss.** This was one of the first trusses of this country in which a scientific arrangement of the parts was observed. It was composed entirely of wood, even iron bolts for splicing the main beams being avoided. It consists in forming both the upper and lower beams (Fig. 152) of three parallel beams, sufficient space being left between the

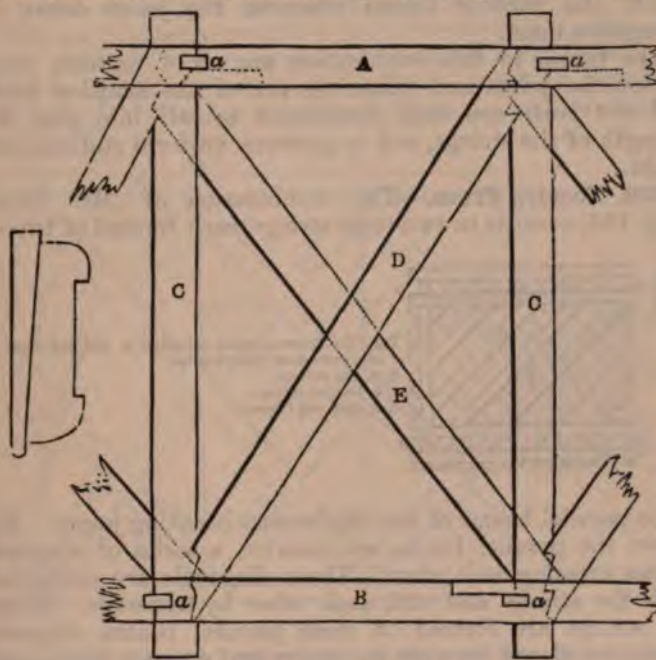

Fig. 152—Represents a panel of Long's truss.  
 A and B, top and bottom strings of three courses.  
 C, C, posts in pairs.  
 D, braces in pairs.  
 E, counter-brace single.  
 a, a, mortises where jibs and keys are inserted.  
 F, jib and key of hard wood.

one in the centre and the other two to insert the cross pieces, termed the *posts*; the posts consist of beams in pairs placed at suitable intervals along the strings, with which they are connected by wedge blocks, termed *jibs* and *keys*, which are inserted into rectangular holes made through the strings, and fitting a corresponding shallow notch cut into each post. A *brace* connects the top of one post with the foot of the one adjacent by a suitable joint. Another diagonal piece, termed the *counter-brace*, is placed crosswise between the two braces and their posts, with its ends abutting against the centre beam of the upper and lower strings. The counter-braces are connected with the posts and braces by wooden pins, termed *tree-nails*.

In wide bearings, the strings require to be made of several beams abutting end to end; in this case the beams should break joints, and short beams should be inserted between the centre and exterior beams wherever the joints occur, to strengthen them.

The beams in this combination are all of uniform cross section, the joints and fastenings are of the simplest kind, and the parts are well distributed to call into play the strength of the strings, and to produce uniform stiffness and strain.

**608. Town's Truss.**—The combination of Mr. Town (Fig. 153) consists in two main strings, each formed of two or

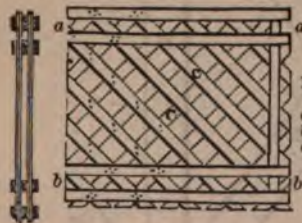

Fig 153.—Represents an elevation A, and end view, B, of a portion of Town's truss.  
*a, a,* top strings.  
*b, b,* bottom strings.  
*c, c,* diagonal braces.

three parallel beams of two thicknesses breaking joints. Between the parallel beams are inserted a series of diagonal beams crossing each other. These diagonals are connected with the strings and with each other by tree-nails. When the strings are formed of three parallel beams, diagonal pieces are placed between the centre and exterior beams, and two intermediate strings are placed between the two courses of diagonals.

This combination, commonly known as the *lattice truss*, is of very easy mechanical execution, the beams being of a uni-

form cross section and length. The strains upon it are borne by the tree-nails, and when used for structures subjected to variable strains and jars, it loses its stiffness and sags between the points of support. It is more commendable for its simplicity than scientific combination.

**609. Howe's Truss.**—This truss consists of (Fig. 154) an upper and lower string, each formed of several thicknesses of beams placed side by side and breaking joints. On the upper side of the lower string and the lower side of the upper, blocks of hard wood are inserted into shallow notches; the blocks are bevelled off on each side to form a suitable point of support, or *step* for the diagonal pieces. One series of the diagonal pieces are arranged in pairs, the others are single and placed between those in pairs. Two strong bolts of iron, which pass through the blocks, connect the upper and lower strings, and are arranged with a screw cut on one end and a nut to draw the parts closely together.

This combination presents a judicious arrangement of the parts. The blocks give abutting surfaces for the braces superior to those obtained by the ordinary forms of joint for this purpose. The bolts replace advantageously the timber

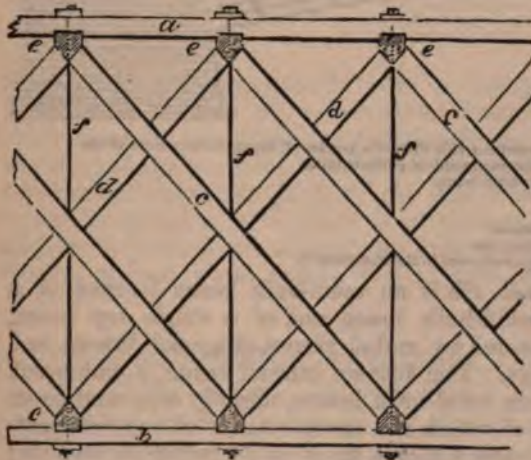

Fig. 154 — Represents an elevation of a portion of Howe's truss.  
 a, top string.  
 b, bottom string.  
 c, c, diagonal braces in pairs.  
 d, single braces.  
 e, e, steps of hard wood for braces.  
 f, f, iron rods with nuts and screws.

posts, and in case of the frame working loose and sagging, their arrangement for tightening up the parts is simple and efficacious.

**610. Schuylkill Bridge.**—This bridge, designed and built by L. Wernwag, has the widest span of any wooden

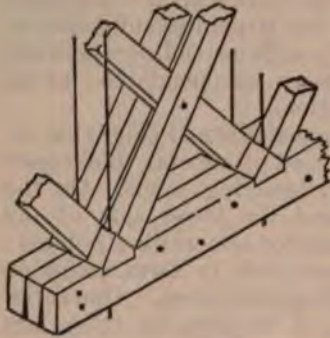

Fig. 86 is a perspective view of a part of one panel of the Howe truss, and shows quite clearly how the parts are arranged. For an analysis of these structures, see Wood's Treatise on Bridges and Roofs.

bridge in this country. The bridge-frame (Fig. 155) consisted

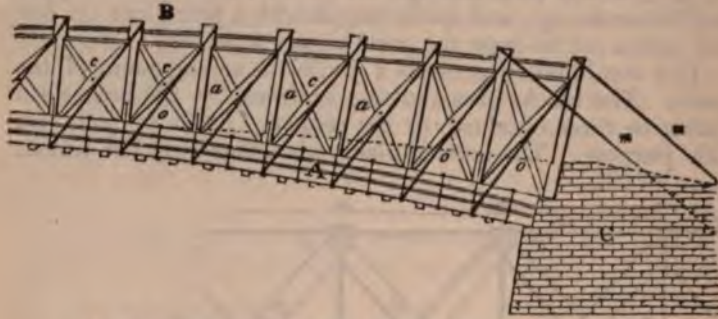

Fig. 155—Represents a side view of a portion of the open-curved rib of the bridge over the Schuylkill at Philadelphia.

A, lower curved built beam.  
B, top beam.  
a, a, posts.  
c, c, diagonal braces.  
o, o, iron diagonal ties.  
m, m, iron stays anchored in the abutment C.

of five ribs. Each rib is an open-built beam formed of a bottom curved solid-built beam and of a single top beam, which are connected by radial pieces, diagonal braces, and inclined iron stays. The bottom curved beam is composed of three concentric solid-built beams, slightly separated from each other, each of which has seven courses of curved scantling in it, each course 6 inches thick by 13 inches in breadth; the courses, as well as the concentric beams, being firmly united by iron bolts, &c. A roadway that rests upon the bottom curved ribs is left on each side of the centre rib, and a footpath between each of the two exterior ribs. The bridge was covered in by a roof and a sheathing on the sides.

611. **Burr's Truss.**—Burr's plan, which (Fig. 156) consists

in forming each rib of an open-built beam of straight timber, and connecting with it a curved solid-built beam formed of two or more thicknesses of scantling, between which the

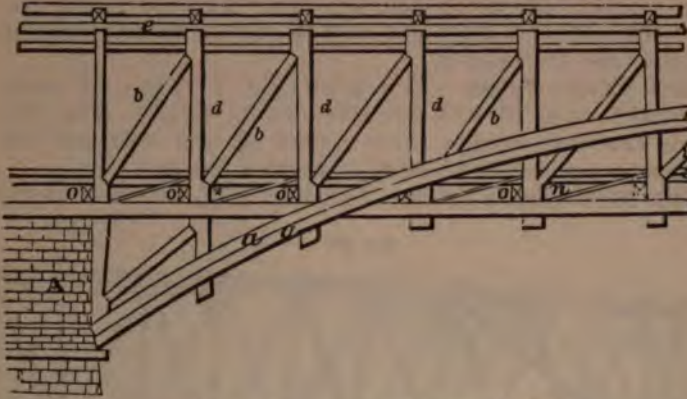

Fig. 156—Represents a side view of a portion of a rib of Barr's bridge.  
*a, a*, arch timbers.  
*d, d*, queen-posts.  
*b, b*, braces.  
*c, c*, chords.

*e, e*, plate of the side frame.  
*o, o*, floor girders on which the flooring joists and flooring boards rest.  
*n, n*, check braces.  
*t, t*, tie-beams of roof.  
*A*, portion of pier.

framework of the open-built beam is clamped. The open-built beam consists of a horizontal bottom beam of two thicknesses of scantling, termed the *chords*, between which are secured the uprights, termed the *queen posts*,—of a single top beam, termed the *plate of the side frame*, which rests upon the uprights, with which it is connected by a mortise and tenon joint,—and of diagonal braces and other smaller braces, termed *check braces*, placed between the uprights.

Fig. 157.



The curved-built beam, termed the *arch-timbers*, is bolted upon the timbers of the open-built beam. The bridge-frame

may consist of two or more ribs, which are connected and stiffened by cross ties and diagonal braces. The roadway-flooring is laid upon cross pieces, termed the *floor girders*, which may either rest upon the chords, or else be attached at any intermediate point between them and the top beam. The roadway and footpaths may be placed in any position between the several ribs.

**612. Pratt's Truss.** This truss (Fig. 157) has the same general form as Howe's, but differs in its details. The verticals here are wooden posts instead of iron rods, and the diagonals are iron ties instead of wooden braces.

**613. McCallum's Truss.** This truss (Fig. 158) is a modi-

Fig. 158.



fication of Howe's, the essential difference of which consists in a curved upper chord instead of a horizontal one. The long braces at the end—called *arch braces*,—are not essential to this system. This system is stiffer than similar ones having horizontal chords.

**614.** A simple but effective structure, shown in Fig. 159,

Fig. 159.

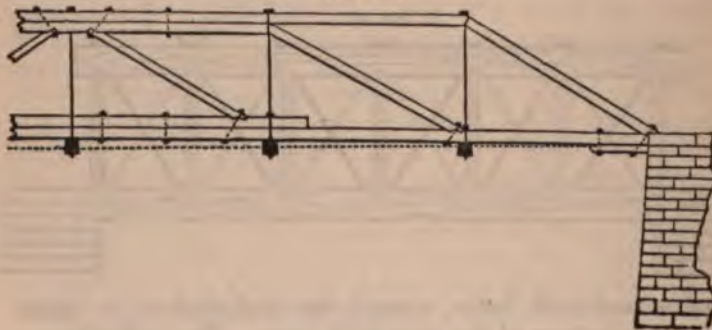

has been in use for some time on the N. Y. State canals for common road bridges, and for crossings on farms. There are no counter-braces, which, as may readily be shown, are unnecessary for short spans. (See Wood's *Treatise on Bridges and Roofs*, pp. 120 and 121.) The lower timber may be spliced, or in any other manner made continuous throughout. Another timber, which is placed on this, extends over two or four of the central bays. The verticals, which are iron rods, are made divergent, as shown in Fig. 159a.

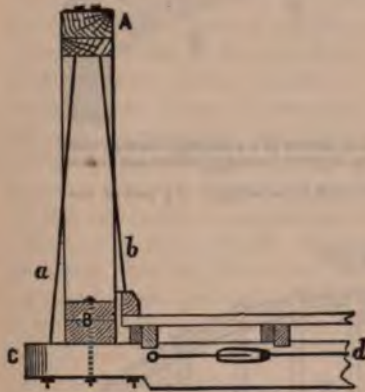

159 a. Cross section of a New York State canal bridge.  
A, upper chord.  
B, lower chord.  
a, b, suspending rods, which incline outward.  
C, a floor-girder.  
d, a diagonal rod.

615. **Wooden Arches.** A wooden arch may be formed by bending a single beam (Fig. 160) and confining its extremi-

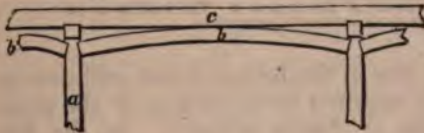

Fig. 160—Represents a horizontal beam c supported at its middle point by a bent beam b.

ties to prevent it from resuming its original shape. A beam in this state presents greater resistance to a cross strain than when straight, and may be used with advantage where great stiffness is required, provided the points of support are of sufficient strength to resist the lateral thrust of the beam. This method can be resorted to only in narrow bearings.

For wide arches a curved-built beam must be adopted; and for this purpose a solid (Figs. 161 and 162) or an open-built beam may be used, depending on the bearing to be spanned by the arch. In either case the curved beams are built in



the same manner as straight beams, the pieces of which they are formed being suitably bent to conform to the curvature of the arch, which may be done either by steaming the pieces, by mechanical power, or by the usual method of softening the woody fibres by keeping the pieces wet while subjected to the heat of a light blaze.

Fig. 161.



Fig. 161—Represents a wooden arch A, formed of a solid-built beam of three courses, which support the beams c, c by the posts g, g, which are formed of pieces in pairs. b, b, inclined struts to strengthen the arch by relieving it of a part of the load on the beams c, c.

Fig. 162.

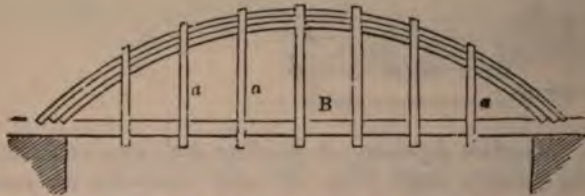

Fig. 162—Represents a wooden arch of a solid-built beam A, which supports the horizontal beam B by means of the posts a, a. The arch is let into the beam B, which acts as a tie to confine its extremities.

616. The number of ribs in the bridge-frame will depend on the general strength required by the object of the structure, and upon the class of frame adopted. In the first class, in which the roadway is usually above the frames, any requisite number of ribs may be used, and they may be placed at equal intervals apart, or else be so placed as to give the best support to the loads which pass over the bridge. In the second class, as the frame usually lies entirely, or projects partly above the roadway, &c., if more than two ribs are required, they are so arranged that one or two, as circumstances may demand, form each head of the bridge, and one or two more are placed midway between the heads, so as to leave a sufficient width of roadway between the centre and adjacent ribs. The footpaths are usually, in this case, either placed

between the two centre ribs, or, when there are two exterior ribs, between them.

617. In frames which exert a lateral pressure against the abutments and piers, the lowest points of the framework should be so placed as to be above the ordinary high-water level; and plates of some metal should be inserted at those points, both of the frame and of the supports, where the effect of the pressure might cause injury to the woody fibre.

618. The roadway usually consists of a simple flooring formed of cross joists, termed the *roadway-bearers*, or *floor-girders*, and flooring-boards, upon which a road-covering either of wood or stone is laid. A more common and better arrangement of the roadway, now in use, consists in laying longitudinal joists of smaller scantling upon the roadway-bearers, to support the flooring-boards. This method preserves more effectually than the other the roadway-bearers from moisture. Besides, in bridges which, from the position of the roadway, do not admit of vertical diagonal braces to stiffen the framework, the only means, in most cases, of effecting this object is in placing horizontal diagonal braces between each pair of roadway-bearers. For like reasons, stone road-coverings for wooden bridges are generally rejected, and one of plank used, which, for a horse-track, should be of two thicknesses, so that, in case of repairs, arising from the wear and tear of travel, the boards resting upon the flooring-joists may not require to be removed. The footpaths consist simply of a slight flooring of sufficient width, which is usually detached from and raised a few inches above the roadway surface.

619. When the bridge-frame is beneath the roadway, a distinct parapet will be requisite for the safety of passengers. This may be formed either of wood, of iron, or of the two combined. It is most generally made of timber, and consists of a hand and foot rail connected by upright posts and stiffened by diagonal braces. A wooden parapet, besides the security it gives to passengers, may be made to add both to the strength and stiffness of the bridge, by constructing it of timber of a suitable size, and connecting it firmly with the exterior ribs.

620. In bridge-frames in which the ribs are above the roadway, a timber sheathing of thin boards will be requisite on the sides, and a roof above, to protect the structure from the weather. The tie-beams of the roof-trusses may serve also as ties for the ribs at top, and may receive horizontal diagonal braces to stiffen the structure, like those of the roadway-

bearers. The rafters, in the case in which there is no central rib, and the bearing, or distance between the exterior ribs, is so great that the roadway-bearers require to be supported in the middle, may serve as points of support for suspension pieces of wood, or of iron, to which the middle point of the roadway-bearers may be attached.

621. The frame and other main timbers of a wooden bridge will not require to be coated with paint, or any like composition, to preserve them from decay when they are roofed and boarded in to keep them dry. When this is not the case, the ordinary preservatives against atmospheric action may be used for them. The under surface and joints of the planks of the roadway may be coated with bituminous mastic when used for a horse-track; in railroad bridges a metallic covering may be suitably used when the bridge is not traversed by horses.

622. Wooden bridges can produce but little other architectural effect than that which naturally springs up in the mind of an educated spectator in regarding any judiciously-contrived structure. When the roadway and parapet are above the bridge-frame, a very simple cornice may be formed by a proper combination of the roadway-timbers and flooring, which, with the parapet, will present not only a pleasing appearance to the eye, but will be of obvious utility in covering the parts beneath from the weather. In covered bridges, the most that can be done will be to paint them with a uniform coat of some subdued tint. At best, from their want of height as compared with their length, covered wooden bridges must, for the most part, be only unsightly, and also apparently insecure structures when looked at from such a point of view as to embrace all the parts in the field of vision; and any attempt, therefore, to disguise their true character, and to give them by painting the appearance of houses, or of stone arches, while it must fail to deceive even the most ignorant, will only betray the bad taste of the architect to the more enlightened judge.

The art of erecting wooden bridges has been carried to great perfection in almost every part of the world where timber has, at any period, been the principal building material at the disposal of the architect; but iron at the present day is fast taking the place of wood in the more important bridges.

623. The following Table contains the principal dimensions of some of the most celebrated American and European wooden bridges:

NAME, ETC., OF BRIDGE.	Number of bays.	Width of widest bay.	Rise or depth of rib.
Wettengen bridge.....	1	390 ft.	—
Bridge of Schaffhausen.....	2	193 "	—
Bridge of Kandel.....	1	166 "	—
Bridge of Bamberg.....	1	208 "	16.9 ft.
Bridge of Freysingen.....	2	153 "	11.6 "
Essex bridge.....	1	250 "	—
Upper Schuylkill bridge.....	1	340 "	20 "
Market-street bridge.....	3	195 "	12 "
Trenton bridge.....	5	200 "	27 "
Columbia bridge.....	29	200 "	—
Richmond bridge.....	19	153 "	15.4 "
Springfield bridge.....	7	180 "	18 "
Susquehanna bridge.....	10	250 "	—

## IV.

## CAST-IRON BRIDGES.

624. Bridges of cast iron admit of even greater boldness of design than those of timber, owing to the superiority, both in strength and durability, of the former over the latter material; and they may therefore be resorted to under circumstances very nearly the same in which a wooden structure would be suitable.

625. The abutments and piers of cast-iron bridges should be built of stone, as the corrosive action of salt water, or even of fresh water when impure, would in time render iron supports of this character insecure; and timber, when exposed to the same destructive agents, is still less durable than cast iron.

626. The curved ribs of cast-iron bridge-frames have undergone various modifications and improvements. In the earlier bridges, they were formed of several concentric arcs, or curved beams, placed at some distance asunder, and united by radial pieces; the spandrels being filled either by contiguous rings, or by vertical pieces of cast iron upon which the roadway bearers were laid.

In the next stage of progress towards improvement, the curved ribs were made less deep, and were each formed of several segments, or panels cast separately in one piece, each panel consisting of three concentric arcs connected by radial pieces, and having flanches, with other suitable arrangements, for connecting them firmly by wrought-iron keys, screw-bolts, &c.; the entire rib thus presenting the appearance of three concentric arcs connected by radial pieces. The spandrels were filled either with panels formed like those of the curved

ribs, with iron rings, or with a lozenge-shaped reticulated combination. The ribs were connected by cast-iron plates and wrought-iron diagonal ties.

In the more recent structures, the ribs have been composed of voussoir-shaped panels, each formed of a solid thin plate with flanches around the edges; or else of a curved tubular rib, formed like those of Polonceau, or of Delafield, described further on. The spandrel-filling is either a reticulated combination, or one of contiguous iron rings. The ribs are usually united by cast-iron tie-plates, and braced by diagonal ties of cast and wrought iron.

609. The roadway-bearers and flooring may be formed either of timber, or of cast iron. In the more recent structures in England, they have been made of the latter material; the roadway-bearers being cast of a suitable form for strength, and for their connection with the ribs; and the flooring-plates being of cast-iron.

The roadway and footpaths, formed in the usual manner, rest upon the flooring-plates.

The parapet consists, in most cases, of a light combination of cast or wrought iron, in keeping with the general style of the structure.

627. The English engineers have taken the lead in this branch of architecture, and, in their more recent structures, have carried it to a high degree of mechanical perfection and architectural elegance. Among the more celebrated cast-iron bridges in England, that of *Coalbrookdale* belongs to the first epoch above mentioned; those of *Staines* and *Sunderland* to the second; and to the third, the bridge of *Southwark* at London; that of *Tewkesbury* over the Severn; that over the *Lary* near Plymouth, and a number of others in various parts of the United Kingdom.

The French engineers have not only followed the lead set them by the English, but have taken a new step, in the tubular-shaped ribs of M. Polonceau. The *Pont des Arts* at Paris, a very light bridge for foot-passengers only, and which is a combination of cast and wrought iron, belongs to their earliest essays in this line; the *Pont d'Austerlitz*, also at Paris, which is a combination similar to those of *Staines* and *Sunderland*, belongs to their second epoch; and the *Pont du Carrousel*, in the same city, built upon Polonceau's system, with several others on the same plan, belong to the last.

In the United States a commencement can hardly be said to have been made in this branch of bridge architecture;

the bridge of eighty feet span, with tubular ribs, constructed by Major Delafield at Brownsville, stands almost alone, and is a step contemporary with that of Polonceau in France.

The following Table contains a summary description of some of the most noted European cast-iron bridges :

NAME OF BRIDGE.	River.	No. of arches.	Span in feet.	Rise in feet.	No. of ribs.	Date.	Engineer.
Coalbrookdale.....	Severn.....	1	100.5	40	5	1779	—
Wearmouth.....	Wear.....	1	240	30	6	1796	Burdon.
Staines.....	.....	1	181	16.5	—	1802	—
Austerlitz.....	Seine.....	5	106.6	10.6	7	1805	Lamandé.
Vauxhall.....	Thames.....	9	78	—	9	1816	Walker.
Southwark.....	Thames.....	3	240	24	8	1818	Rennie.
Tewkesbury.....	Severn.....	1	170	17	6	—	Telford.
Lary.....	Lary.....	5	100	14.5	5	1827	Rendel.
Carrusel.....	Seine.....	3	150	16	5	1838	Polonceau.

**628. Iron Arches.** Cast-iron arches may be used for the same objects as those of timber. The frames for these purposes consist of several parallel ribs of uniform dimensions, which are cast into an arch form, the ribs being connected by horizontal ties, and stiffened by diagonal braces. The weight of the superstructure is transmitted to the curved ribs in a variety of ways; most usually by an open cast-iron beam, the lower part of which is so shaped as to rest upon the curved rib, and the upper part suitably formed for the object in view. These beams are also connected by ties, and stiffened by diagonal braces.

Each rib, except for narrow spans, is composed of several pieces, or segments, between each pair of which there is a

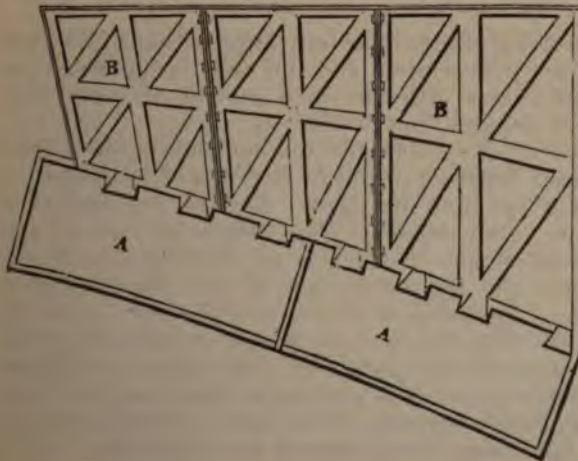

Fig. 163—Represents a portion of a cast-iron plate arch with an open cast-iron beam.  
A, A, segments of the arch.  
B, B, panels of the open beam connected at the joints *a b*.

joint in the direction of the radius of curvature. The form and dimensions of the segments are uniform. The segments are usually either solid (Fig. 163) or open plates of uniform thickness, having a flanch of uniform breadth and depth at each end, and on the entrados and intrados. The flanch serves both to give strength to the segment and to form the connection between the segments and the parts which rest upon the rib.

The ribs are connected by tie-plates, which are inserted between the joints of the segments, and are fastened to the segments by iron screw bolts, which pass through the end flanches of the segments and the tie-plate between them. The tie-plates may be either open or solid; the former being usually preferred on account of their superior lightness and cheapness.

The framework of the ribs is stiffened by diagonal pieces, which are connected either with the ribs or the tie-plates. The diagonal braces are cast in one piece, the arms being ribbed, or *feathered*, and tapering from the centre towards the ends in a suitable manner to give lightness combined with strength.

The open beams (Fig. 163), which rest upon the curved ribs, are cast in a suitable number of panels; the joint between each pair being either in the direction of the radii of the arch, or else vertical. These pieces are also cast with flanches, by which they are connected together, and with the other parts of the frame. The beams, like the ribs, are tied together and stiffened by ties and diagonal braces.

Beams of suitable forms for the purposes of the structure are placed either lengthwise or crosswise upon the open beams.

629. Curved ribs of a tubular form have, within a few years back, been tried with success, and bid fair to supersede the ordinary plate rib, as with the same amount of metal they combine more strength than the flat rib.

The application of tubular ribs was first made in the United States by Major Delafield of the U. S. Corps of Engineers, in an arch for a bridge of 80 feet span. Each rib was formed of nine segments; each segment (Fig. 164) being cast in one piece, the cross section of which is an elliptical ring of uniform thickness, the transverse axis of the ellipse being in the direction of the radius of curvature of the rib. A broad elliptical flanch with ribs, or stays, is cast on each end of the segment, to connect the parts with each other; and three *chairs*, or *saddle-pieces*, with grooves in them, are cast upon the entrados of each segment, and at equal intervals apart, to receive the open beam which rests on the curved rib.

The ribs are connected by an open tie plate (Fig. 164). Raised elliptical projections are cast on each face of the tie plate, where it is connected with the segments, which are adjusted accurately to the interior surface of each pair of segments, between which the tie plate is embraced. The segments and plate are fastened by screw bolts passed through the end flanches of the segments.

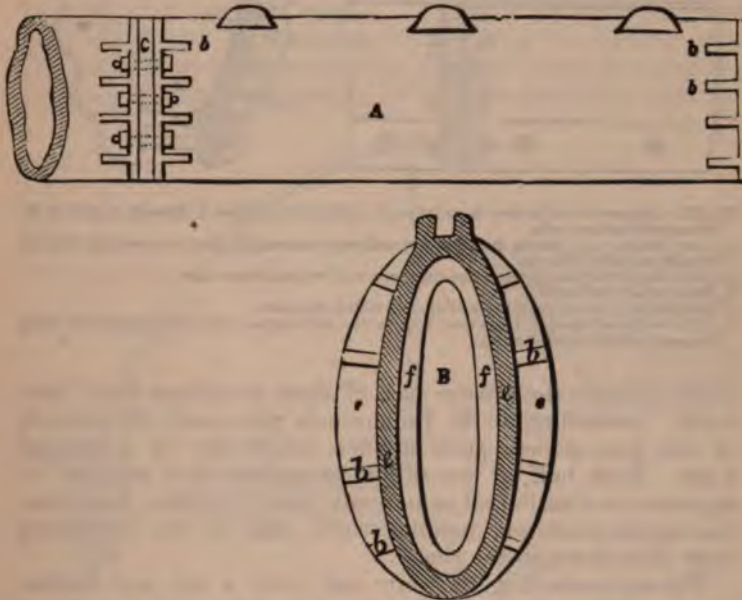

Fig. 164—Represents a side view A, and a cross section and end view B, through a saddle-piece of the tubular arch of Major Delafield.

*a, a* (Fig. A), a side view, and (Fig. B) an end view of the elliptical flanches of the end of each segment.

*b, b*, shoulders, or ribs to strengthen the flanches against lateral strains.

*c*, tie-plate, between the ribs.

*f*, (Fig. B) side view of the rim of the tie-plate fitted to the interior of the tube.

*d, d*, (Figs. A and B) saddle-pieces to receive the open beams of a form similar to Fig. 163, which rest on the tubular ribs.

*z*, cross section of the rib through the saddle-piece.

The tie plates form the only connection between the curved ribs; the broad-ribbed flanches of the segments, and the raised rims of the tie plates inserted into the ends of the tubes, giving all the advantages and stiffness of diagonal pieces.

630. Tubular ribs with an elliptical cross section have been used in France for many of their bridges. They were first introduced but a few years back by M. Polonceau, after



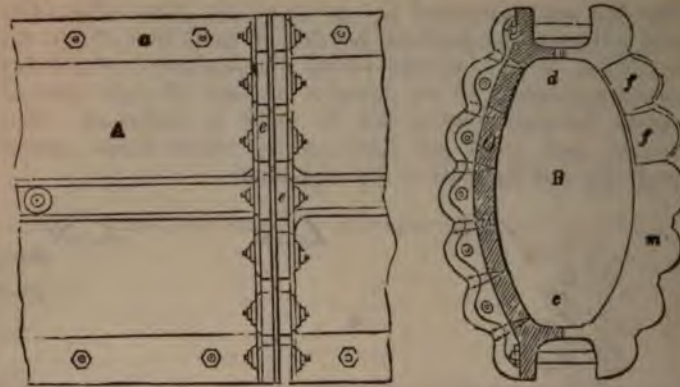

Fig. 165.—Represents a side view A, and a cross section and end view B, through a joint of M. Polonceau's tubular arch.  
*a*, *a*, top flanch, *b*, *b*, bottom flanch of the semi-segments united along the vertical joint *c* through the axis of the rib.  
*g* *A*, side view of the joint between the flanches *e*, *e* of two semi-segments.  
*m*, inner side of the flanches.  
*c*, cross section of a semi-segment and top and bottom flanches.  
*f*, *f*, thin wedges of wrought iron placed between the end flanches of the semi-segments to bring the parts to their proper bearing.

whose designs the greater part of these structures have been built. According to M. Polonceau's plan, each rib consists of two symmetrical parts divided lengthwise by a vertical joint. Each half of the rib is composed of a number of segments so distributed as to break joints, in order that when the segments are put together there shall be no continuous cross joint through the ribs.

The segments (Fig. 165) are cast with a top and bottom flanch, and one also at each end. The halves of the rib are connected by bolts through the upper and lower flanches, and the segments by bolts through the end flanches.

For the purposes of adjusting the segments and bringing the rib to a suitable degree of tension, flat pieces of wrought iron of a wedge shape are driven into the joints between the segments, and are confined in the joints by the bolts which fasten the segments and which also pass through these wedges.

To connect the ribs with each other, iron tubular pieces are placed between them, the ends of the tubes being suitably adjusted to the sides of the ribs. Wrought-iron rods which serve as ties pass through the tubes and ribs, being arranged with screws and nuts to draw the ribs firmly against the tubular pieces. Diagonal pieces of a suitable form are

placed between the ribs to give them the requisite degree of stiffness.

In the bridges constructed by M. Polonceau according to this plan, he supports the longitudinal beams of the roadway by cast-iron rings which are fastened to the ribs and to each other, and bear a chair of suitable form to receive the beams.

631. Open cast-iron beams are seldom used except in combination with cast-iron arches. Those of wrought iron are frequently used in structures. They may be formed of a top and bottom rail connected by diagonal pieces, forming the ordinary lattice arrangement, or a piece bent into a curved

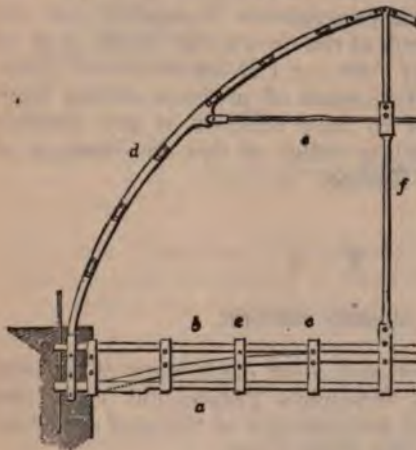

Fig. 166—Represents an open beam of wrought iron consisting of a top and bottom rail *a* and *b*, with an intermediate curved piece, the whole secured by the pieces *c*, *c*, in pairs bolted to them. *d*, *e*, and *f* represent the parts of a truss of a curved light roof, connected with the open beam; and also the manner in which the whole are secured to the wall.

form may be placed between the rails, or any other suitable combination (Fig. 166) may be used which combines lightness with strength and stiffness.

632. **Effects of Temperature on Stone and Cast-iron Bridges.** The action of variations of temperature upon masses of masonry, particularly in the coping, has already been noticed. The effect of the same action upon the equilibrium of arches was first observed by M. Vicat in the stone bridge built by him at Souillac, in the joints of which periodical changes were found to take place, not only from the ranges of temperature between the seasons, but even daily. Similar phenomena were also very accurately noted by Mr. George Rennie in a stone bridge at Staines.

From these recorded observations the fact is conclusively established, that the joints of stone bridges, both in the arches

and spandrels, are periodically affected by this action, which must consequently at times throw an increased amount of pressure upon the abutments, but without, under ordinary circumstances, any danger to the permanent stability of the structure.

When iron was first proposed to be employed for bridges, objections were brought against it on the ground of the effect of changes of temperature upon this metal. The failure in the abutments of the iron bridge at Staines was imputed to this cause, and like objections were seriously urged against other structures about to be erected in England. To put this matter at rest, observations were very carefully made by Sir John Rennie upon the arches of Southwark bridge, built by his father. From these experiments it appears that the mean rise of the centre arch at the crown was about  $\frac{1}{10}$ th of an inch for each degree of Fahr., or 1.25 inches for 50° Fahr. The change of form and increase of pressure arising from this cause do not appear to have affected in any sensible degree the permanent stability either of this structure, or of any of a like character in Europe.

## V.

## IRON TRUSSED BRIDGES.

633. AMONG the earliest and most meritorious of the iron bridges of this country is Whipple's Trapezoidal Truss (see Fig. 167). So far as the arrangement of ties and struts are concerned it is similar to the Pratt Truss.



Fig. 167.—The upper chord is of cast-iron and made in sections, the length of each piece being equal to the length of a bay. The lower chord is composed of a succession of links (see Fig. 168), which receive cast-iron blocks at their ends. The cast-iron blocks form steps for securing the lower ends of the vertical posts. The posts have openings near the middle of their length, through which the main and counter-ties pass. The posts are trussed at the middle, as shown in the figure.

In this truss the end members are inclined, so that the general form of the outline is that of a trapezoid. All un-

necessary members are omitted, and hence, comparatively few counter-ties are used. In the Fig. only two are shown—one each side of the centre. The number of counter-ties depends upon the relation of the moving load to that of the weight of the bridge (see articles 107 and 108 of Wood's *Treatise on Bridges and Roofs*).

The lower chord is sometimes made of links of iron (Fig. 168), which pass over cast-iron blocks under the vertical



Fig 168.—One of the links of the lower chord.

posts (Fig. 169). The lower chord may be, and at the pres-



Fig 169.—A joint in the lower chord of a Whipple Truss.

ent day often is, made of eye-bars (Fig. 170). The proper

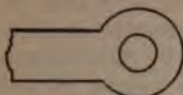

Fig. 170.—One end of an eye-bar used in tension members of bridges and roofs.

form and dimensions of the eyes and the proper size of the pins has been the subject of considerable experiment.

At first it was supposed that the total section on both sides of the eye should equal half the section of the pin, but experiments quickly showed that when made in this proportion the eyes would tear out before the shearing strength of the pin was reached. According to some experiments made by Sir Charles Fox, he concluded that it was best to make the bearing surface between the pin and concave surface of the eye about equal to the least section of the link; or, in other words, the diameter of the pin should equal about two-thirds of the diameter of the link.

This rule, however, is not rigidly adhered to by our most eminent bridge builders. Each has a rule of his own. Some make the eye thicker than the link; others make them somewhat pear-shaped by adding material back of the eye (Fig 171); while still others make them of the form shown in Fig 172.



Fig 171.—Form of eye-bar.

But in all cases the total section of the material through the eye is made to exceed that through the bar, and the section of the pin also exceeds that of the bar.

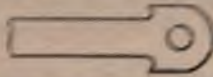

Fig. 113—Another form of eye-bar.

**624. Modifications of Whipple's Truss.** Different bridge builders have modified the details of Whipple's Truss, so as to suit their convenience or fancy, or to make them conform with modern practice. It is useless to attempt to give all these modifications. They have, however, given rise to certain names of bridges, such as the Murphy-Whipple bridge, Linville bridge, Jones's bridge, etc., etc.

**625. Linville Bridge.** This bridge, the details of which (Figs. 173 and 174) have been very thoroughly and carefully worked out, has a wide reputation.

The improvements consist in employing tubular forms of wrought iron for members used to resist compressive strains, and weldless eye-bars to resist tensile strains, by this means economizing material and reducing the dead weight of the structures. In the accompanying details of the chords, struts, and ties, and the floor system and lateral connections, some of the leading principles of the Linville truss are illustrated.

The upper chords A, are composed of channel (C) bars and I beams, to which are riveted top plates, and sometimes bottom plates, forming a tubular compressive member of great strength. When the lower plate is used, elliptical holes are cut out in order to admit of painting the interior. The chords are generally made in sections, one panel in length. The connection between the suspension ties and upper chords are effected by means of angle blocks, through which pass the suspension ties, with enlarged screw threads and nuts for adjustment, or by means of pins passing through the chords, and through loops or eyes on the suspension ties.

The struts B are circular or polygonal tubes (Fig. 174a), composed of two or more rolled bars united by rivets through flanges, or by transverse tie-bolts passing through the struts between the flanges. The struts are generally swelled and opened to allow the interior to be repainted in order to prevent their rapid destruction by oxydation.

The lower chords are made by upsetting the enlarged eye ends, by compressing them when highly heated into moulds or dies. They are afterwards forged and rewelded under a hammer.

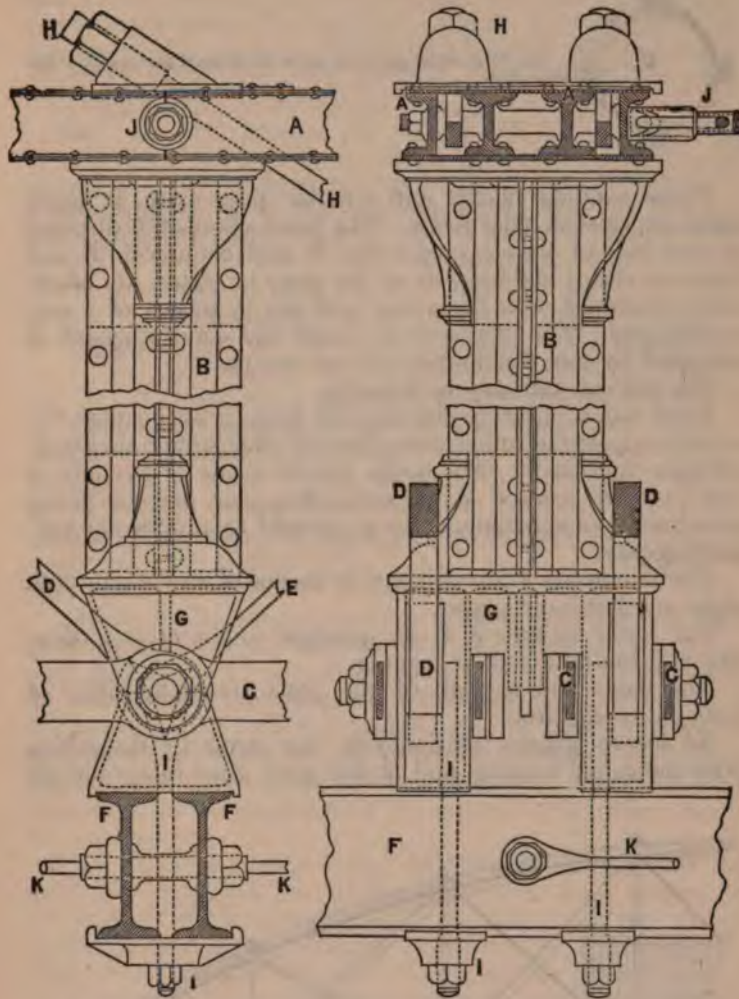

Figs. 173, 174—Details of Linville's truss. Fig. 173 is a cross section, and Fig. 174 a right section of a portion of the truss.

- A A, upper chord, composed of channel bars (I) and I sections. B, the post. (See Fig. 174 A.)
- C C, the lower chord. D D, the lower end of a main tie; and H H, the upper end of
- E E, a counter-tie.
- F F, main tie.
- G G, bases of the posts or struts.
- I I, suspenders for supporting cross-ties.
- J, cross horizontal diagonal tie.
- K, horizontal diagona. tie.



Fig. 174 A—Cross section of one of the forms of post used in a Lärville truss.

These weldless chords and tubular posts have, in many cases, superseded older forms. The lower chords *CC* disposed at each side of the suspension ties *D*, and counter-tie *E*, and between ribs in the bases *G* of the posts or struts, are effectually combined with the struts and ties by means of a connecting-pin. The tendency to bend the connecting-pin is obviated by this distribution of the strains.

The pin can fail only by shearing.

From the connecting-pins depend loops or suspenders, *II*, which support the rolled cross-girders *F*, that sustain the track-stringers and track. The upper lateral struts of wrought or cast iron are secured at the connecting-pins, the ties being attached to an eye-plate, or in a jaw-nut secured to the connecting-pins.

The lateral ties *J* are adjusted by means of sleeve-nuts with right and left hand-screws.

The lower laterals *KK* are attached to the cross girders, and adjusted in a similar manner.

The bases and capitals of the posts are made either of wrought or cast iron.

To secure greater efficiency in the struts by dispensing with the round bearing, and at the same time retain the pin



Fig. 175—An Arched Truss after the general plan of Whipple's. The lower chords or tie rods pass through the ends of the arch, and are secured by nuts on the ends of the rods.

connection between the chords and ties, the lower chords are brought compactly together between and outside of the suspension-ties and suspenders, and a bearing provided on the upper edges of the chords for the lower ends of the posts. The upper ends also have a flat bearing.

636. **Arched Truss.** Fig. 175 shows the general form of a Whipple Arched Truss. The upper chord is composed of hollow tubes, made in sections of about a panel length.

637. **Bollman's Truss.** The general outline of Bollman's Truss is shown in Fig. 176.

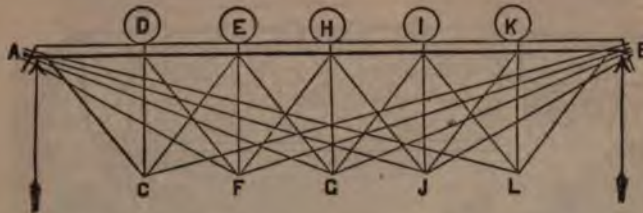

Fig 176—Bollman's Truss. A D, D E, etc., are sections of the upper chord—cast iron and usually hollow. D C, E F, etc., are hollow cast-iron posts. A C, C B; A F, F B, etc., are tension rods; D F, C E, etc., are panel rods.

One of the leading features of this bridge is, the load at each post or joint is carried *directly* to the supports at the ends by means of a pair of tension (or suspension) rods. Thus a load at E is supported by the post E F, and is thence supported by the rods A F and F B. The panel rods D F, E C, E G, etc., serve to keep the upper chord in place, and in case of an undue strain upon, or failure of, one of the long suspension-rods, may transmit the strains to the other members of the truss.

The suspension rods being of unequal length will be unequally elongated or contracted by the same strain, or by changes in the temperature. In order to prevent severe cross strains upon the posts due to these causes, the suspension rods are connected to the lower ends of the posts by means of a link which is a few inches in length, and which permits of a small lateral movement at the ends of the rods without any corresponding movement of the posts. The suspension-rods are made of flat iron, and pass through the ends of the upper chord where they are secured by means of pins which pass through the ends of the chords.

If the roadway passes above the upper chord, it is called a deck bridge, and the lower chord may be dispensed with.



But if it passes on the level of the lower chord (Fig. 176a.) the lower chord may be simply suspended upon the posts; and not be depended upon for resisting tension. The lower chord in this case may also be entirely dispensed with; for cross-ties, or joists, may be secured to the posts and longitudinal joints be placed upon them. If the lower chord is used and is made continuous so as to resist tension, it vir-



Fig. 176a.

tually changes it into a Whipple truss in which the long suspension-rods are unnecessary members. Still, in this case, the truss—especially the panel rods, are not so proportioned as to make it safe to omit the long suspension-rods.

638. **Fink Truss.** The outline or skeleton of a Fink truss is shown in Fig. 177.

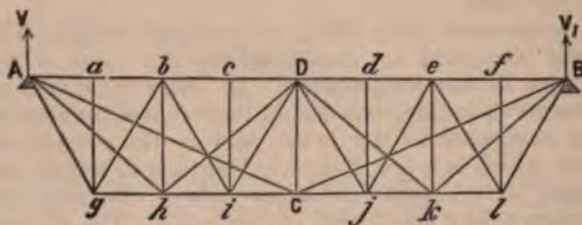

Fig. 177—Fink Truss. A B the upper chord,  $g l$  the lower chord,  $\alpha \rho, b h$ , etc., are posts. A C, C B long suspension-rods. A h, h D, etc., secondary suspension-rods.

This truss consists of a primary system of king posts, A C B, Fig. 177; two secondary systems, A h D and D k B; four tertiary systems, A g b, b i D, D j e, and e l B, and so on.

The posts, suspension-rods and chords may be similar in detail to the systems previously described.

The noted Louisville bridge, across the Ohio River at Louisville, is made upon this plan.

DIMENSIONS OF THE LOUISVILLE BRIDGE.

It is 5,294 feet long, divided into the following spans from centre to centre of piers:

Kentucky abutment.....	32.5 feet.
2 spans of 50 feet.....	100.0 "
1 pivot-draw over canal.....	264.0 "
4 spans of 149.6.....	598.4 "
2 spans of 180.0.....	360.0 "
2 spans of 210.0.....	420.0 "
2 spans of 227.0.....	454.0 "
1 span of 370.0.....	370.0 "
6 spans of 245.5.....	1,473.0 "
1 span of 400.....	400.0 "
3 spans of 180.....	540.0 "
1 span of 149.6.....	149.6 "
1 span of 100.....	100.0 "
Indiana abutment.....	32.5 "

Total length..... 5,294.0 "

**639. Post's Truss.** The main peculiarity of this truss is in its form. The upper ends of the posts are carried towards the centre of the bridge, an amount equal to half a bay, and as all the bays are equal the posts in each half of the truss are all parallel to each other (Fig. 178).

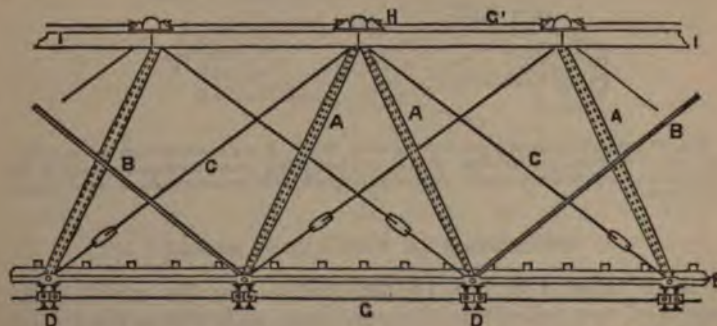

Fig. 178.—Side view of panels of a Post Truss. A A are struts. B B, main ties. C C, counter ties. E E, bottom chords. I I, top chords. D, ends of floor-beams. G, lower horizontal diagonal ties. G', upper horizontal diagonal ties.

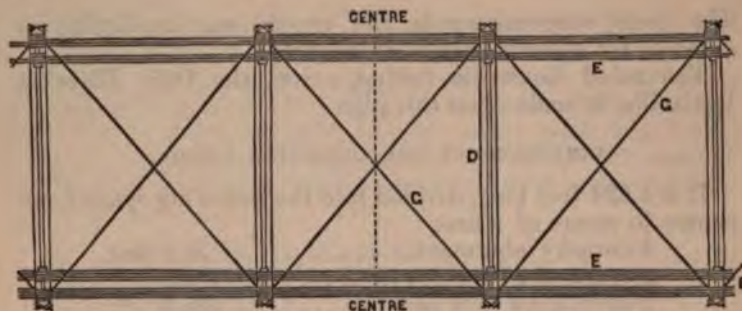

Fig. 179—Plan of the roadway. G G are brace-rods. E E, bottom chord. D are floor-beams.

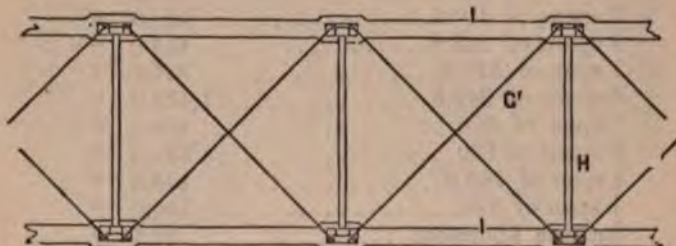

Fig. 180—Plan of the top of the bridge. I, top chord. H, cross-tie or strut. C', upper horizontal tie.

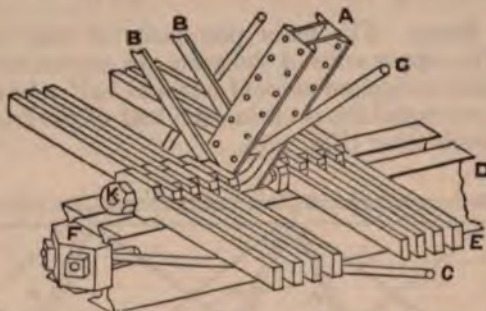

Fig. 181—Shows details at a joint of the lower chord. F is a cast-iron block for receiving the ends of the horizontal tie-rods. K is an iron bolt which passes through the ends of the links which form the lower chord. The other letters refer to the same parts as in the preceding figures.

#### DESCRIPTION OF POST'S IRON BRIDGE.

A A (Figs. 178, 179, 180 and 181)—Are the *struts*, composed of two rolled-iron channel bars, with plates riveted on their flanges, forming a hollow column having a rectangular cross-section. The struts are swelled in the centre by spring-

ing the channel-bars and having the plates sheared to the required shape.

The bearings of the struts upon the pins (K) are of either cast or wrought iron, and are enclosed between the side-plates, and abut against the channel-bars, and are riveted to both. The pin holes are bored through shoes and plates.

B B—Are the *main ties*, or main suspension braces, and are made of flat bar-iron with die-forged heads at the ends, bored out to fit the pins.

C C—Are the *counter ties*, made of round iron, with forged eyes at the ends to receive the pins, and having turn-buckles at a convenient distance from the bottom end, for purposes of adjustment.

D D—Are the floor-beams, suspended in pairs from the chord pins at each panel point, by means of eye-bolts or by stirrups passing over the chord pins and under a bolt through the webs of the beams.

E E—Are the bottom chord bars or links, made of flat bar-iron, with die-forged heads, and bored holes for the chord pins. The sizes of the bars in the respective panels are determined by the strains, the first and second panels having two bars, the third and fourth having four bars each, the fifth and sixth having six bars each, etc., to the centre of the span.

F—Is a bottom lateral brace angle block of cast iron, fastened to the ends of the floor-beams, which form the bottom lateral strut.

G G—Are the lateral brace-rods, of round iron, having screws and nuts at their ends, for adjustment.

H H—Are top lateral struts, made of rolled-iron I beams, or channel bars in pairs. These struts have a cast-iron shoe at their ends, and are bolted to the top plate of the top chord, by bolts passing through shoes, top plate of chord, and through the joint box in the top chord. The top lateral brace rods pass through the cast-iron shoes, with nuts on the outside.

I I—Are the top chords. When made of wrought iron they are composed of channel bars with covering plate riveted to the flanges on the top, and bars riveted at intervals across the bottom flanges, either diagonally or straight across to keep the channel bars in line. Additional sectional area is obtained by riveting plates on the inside of the channel bars.

The top chords are made in panel lengths, with their ends squared by machinery to insure true bearings—and when of cast iron have a rectangular cross-section, with the inside cored out to obtain the necessary sectional area to provide for the compression strain.

The connection of the struts and main and counter braces is made by means of a pin passing through a cast-iron box which encloses the mall, the length of the pin being just equal to the width of the box. The top-chord sections have a recess which fits over the box, and when the connection is made in the box the pieces of top chord are laid on, and cover the whole. The joint is then secured by the bolts which pass through the top lateral strut, top chord and joint box.

**DESCRIPTION OF POST'S "COMBINATION" OR "COMPOSITE" BRIDGE.**

This bridge is composed partly of wood and partly of iron, as shown in Figs. 181*a*, 181*b*, and 181*c*.

A, A—Top chord, packed and framed as shown in Figs. 181*a* and 181*b*.

B B—Struts, framed with square end at the top entering and abutting against joint box E (Fig. 181*b*) and fitted at bottom ends into strut shoe K (Fig. 181*c*).

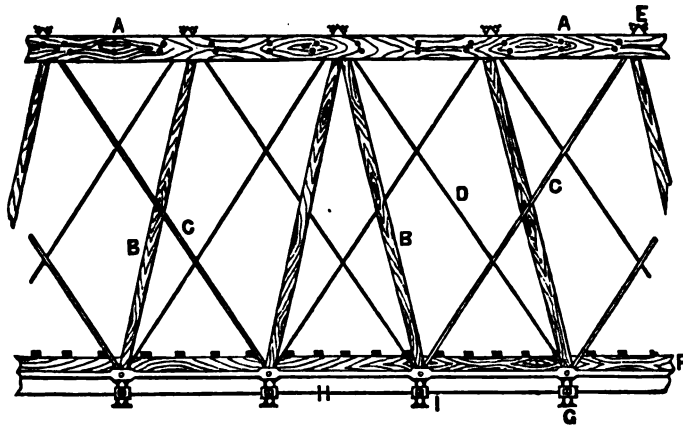

Fig. 181*a*.

C C—Main suspension ties, of square, round or flat iron, with eye at lower end and screw at upper end, passing through joint box E, secured by nuts.

D D—Counter braces, of square or round iron, made similar to main ties.

E E—Cast-iron joint boxes enclosed in top chord, and receiving the struts, main ties and counters.

This box has a flange around the bottom to support the weight of the top chord, which lies upon and is bolted to it.

F F—Bottom chord links of flat iron, with heads at each end, bored to receive the pins (Fig. 181*c*).



Fig. 181*b*.

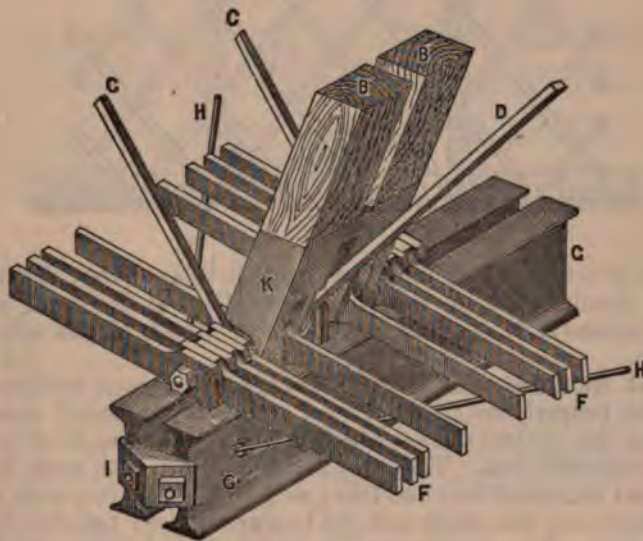

Fig. 181*c*.

G G—Rolled iron floor-beams, suspended to chord pins.

H H—Bottom lateral ties, round iron rods with screws.

I I—Bottom lateral angle block, cast iron.

K—Cast-iron strut shoes, having sockets to receive struts

and drilled holes for chord pins passing through flanges or ribs below the sockets.

**640. Alleghany River Bridge at Pittsburgh, Pa.** This is a lattice iron bridge (Fig. 182), and is similar to several

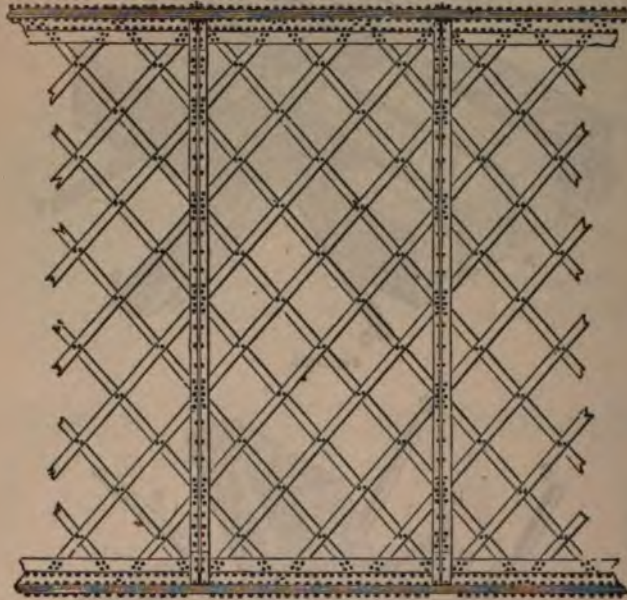

Fig. 182.

other structures which have been made in this country. There is a similar one on the New York Central Railroad, at Schenectady, N. Y., and another near Rome, of the same State.

**641. St. Louis and Illinois Bridge.** This noted structure might properly be called a steel arch. It consists of three spans, the central one of which is 515 feet, and each of the end ones 497 feet. There are eight arches in each span, arranged in sets of two and two; and in each set one arch is directly over the other, and the two are trussed together by link-bars. The arches are composed of steel tubes, which are made of steel staves, as will now be explained.

All the steel in this structure is of the very best quality. The standard fixed for it by the Chief Engineer, Capt. Eads, was so high as to make it almost impossible for our best steel manufacturers to produce it. The coefficient of elasticity was

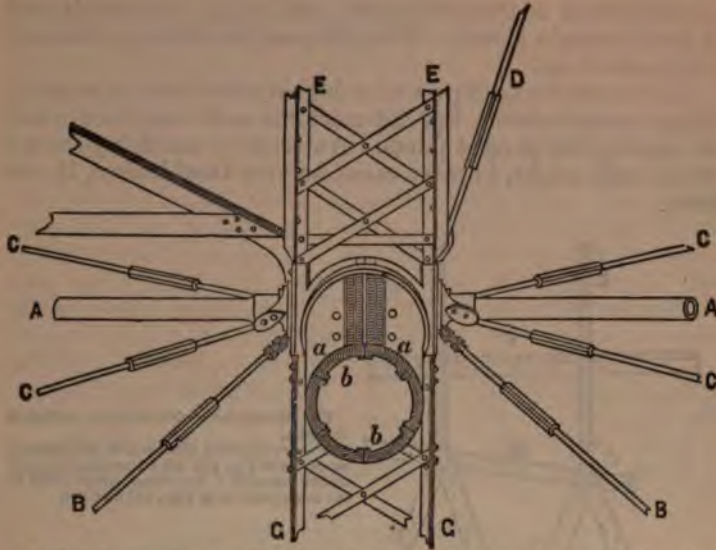

Fig. 183—Section of a tube, St. Louis and Illinois Bridge. *a a* is a steel casing about three-eighths of an inch thick, which is lapped over, and riveted like the plates of a steam-boiler. *b, b* are steel staves which are forced into the casing.  
*A A*, Figs. 183 and 184, are cross-rods for connecting the arches together laterally.  
*B B B* are diagonal rods in a vertical, for connecting the upper arch in one set to the lower arch in the adjacent set.  
*C C C* are diagonal rods in the plane of the tubes, for connecting the joint of one set with the joint which is in advance of or back of the corresponding joint in the adjacent set.  
*D* is a vertical diagonal rod for trussing the roadway.  
*E E* are trussed vertical posts, the lower ends of which are secured to the arch, and the upper ends support the roadway.

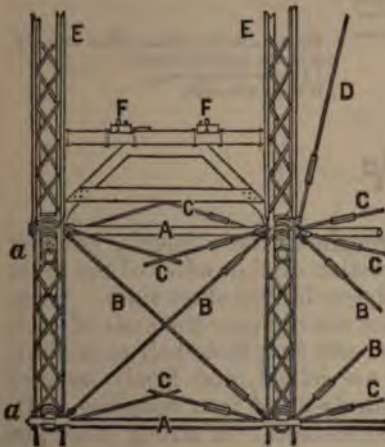

Fig. 184—Is a cross-section of two arches of the bridge. Two sets of tubes which form the arch are shown, also the posts and rods which have been described above.  
*F F* is the track for a railroad; the carriage road passing above this.



to be between 26,000,000 pounds and 30,000,000 pounds, and it was to sustain a strain of 60,000 pounds, without producing a permanent set.

All the workmanship is of a higher order than is usual in bridge construction. Special machines and tools were made for making the several joints. An error of one thirty-second of an inch might, in most cases, be very troublesome, if not fatal.

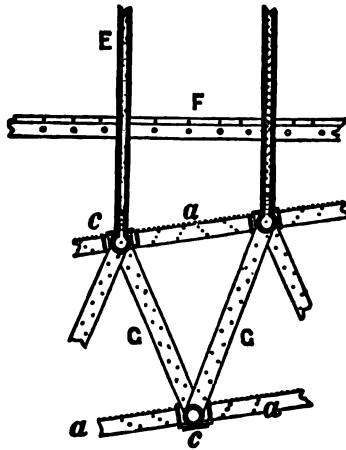

Fig. 185—Shows a side view of a portion of the arch.  
G G are diagonal posts which are trussed, as shown in Fig. 183, for connecting the two arches together. The other letters refer to the same parts as in Figs. 183 and 184.

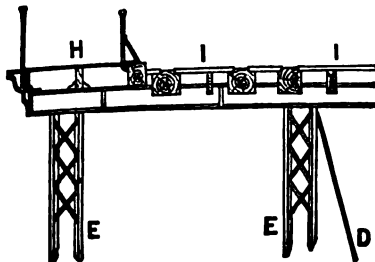

Fig. 186—Shows a cross-section of a portion of the upper roadway.  
I I is the carriage-way.  
H is the side-walk.

The tubes are straight throughout their length, but the ends are planed off in the direction of the radius of the arch, so that the arch is really a polygon having short sides. Several rectangular annular grooves are cut near the ends of each tube; and after the tubes are put in place, their ends abutting against each other, they are joined, and firmly secured by means of a heavy and nicely-fitted iron coupling. In this way the arch is made continuous. A strong steel pin

passes through the coupling and the ends of the tubes, one half of the pin being in each tube. One length of tube is put up at a time, and is connected to all the others, which are properly placed by cross-rods, A A, Figs. 183 and 184, and also diagonal rods C C and B B. The diagonals G G are also secured. These are secured to the pins *c c*, Fig. 185. The vertical posts E E, which support the railroad, are trussed by means of diagonal bars, as shown in Fig. 184. Each skew-back of the arch is secured to the abutments by means of two six-inch steel rods or bolts, which pass through the wrought-iron skew-backs, and several feet into the masonry. This bridge, when completed, will be one of the most remarkable structures of its kind in the world, and can hardly fail to establish many important principles in iron structures.

**642. Kulenberg Bridge.** The span of this bridge is about the same as that of the St. Louis and Illinois bridge, as will be seen from the following dimensions. The lower chord of this bridge (Fig. 187) is horizontal, and the upper chord is

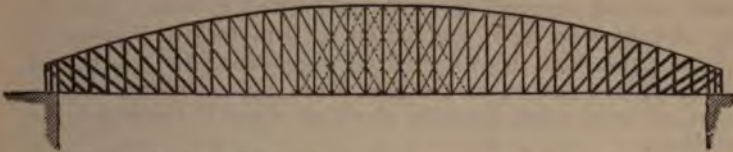

Fig. 187.—Kulenberg Bridge. Span between the abutments, 152 meters. Total length, including the parts on the abutments, 156.8 meters (about 515 feet). Length of each bay, 4 meters. Depth of the truss at the centre, 29 meters.

the arc of a circle, the radius of which is 809 feet. It is of the general plan of the Pratt or Whipple systems, only that the upper chord is curved.

## VI.

### TUBULAR BRIDGES.

**643. Tubular Frames of Wrought-iron.** Except for the obvious application to steam boilers, sheet iron had not been considered as suitable for structures demanding great strength, from its apparent deficiency in rigidity; and although the principle of gaining strength by a proper distribution of the material, and of giving any desirable rigidity by combinations adapted to the object in view, were at every moment acted upon, from the ever-increasing demands of the art, engineers seem not to have looked upon sheet iron as suited to such

purposes, until an extraordinary case occurred which seemed about to baffle all the means hitherto employed. The occasion arose when it became a question to throw a bridge of rigid material, for a railroad, across the Menai Straits; suspension systems, from their flexibility, and some actual failures, being, in the opinion of the ablest European engineers, unsuitable for this kind of communication.

Robert Stephenson, who for some years held the highest rank among English engineers, appears, from undisputed testimony, to have been the first to entertain the novel and bold idea of spanning the Straits by a tube of sheet iron, supported on piers, of sufficient dimensions for the passage within it of the usual trains of railroads. The preliminary experiments for testing the practicability of this conception, and the working out of the details of its execution, were left chiefly in the hands of Mr. William Fairbairn, to whom the profession owes many valuable papers and facts on professional topics. This gentleman, who, to a thorough acquaintance with the mode of conducting such experiments, united great zeal and judgment, carried through the task committed to him; proceeding step by step, until conviction so firm took the place of apprehension, that he rejected all suggestions for the use of any auxiliary means, and urged, from his crowning experiment, reliance upon the tube alone as equal to the end to be attained.

Numerous experiments were made by him upon tubes of circular, elliptical, and rectangular cross-section. The object chiefly kept in view in these experiments was to determine the form of cross-section which, when the tube was submitted to a cross strain, would present an equality of resistance in the parts brought into compression and extension. It was shown, at an early stage of the operations, that the circular and elliptical forms were too weak in the parts submitted to compression, but that the elliptical was the stronger of the two; and that, whatever form might be adopted, extraordinary means would be requisite to prevent the parts submitted to compression from yielding, by "puckering" and doubling. To meet this last difficulty, the fortunate expedient was hit upon of making the part of the main tube, upon which the strain of compression was brought, of a series of smaller tubes, or cells of a curved or a rectangular cross-section. The latter form of section was adopted definitively for the main tube, as having yielded the most satisfactory results as to resistance; and also for the smaller tubes, or cells, as most easy of construction and repair.

As a detail of each of these experiments would occupy more space than can be given in this work, that alone of the tube which gave results that led to the forms and dimensions adopted for the tubular bridges subsequently constructed, will be given in this place.

**644. Model Tube.** The total length of the tube was 78 feet. The distance, or bearing between the points of support on which it was placed to test its strength, was 75 ft. Total depth of the tube at the middle, 4 ft.  $6\frac{1}{4}$  in. Depth at each extremity, 4 ft. Breadth, 2 ft. 8 in.

The top of the tube was composed of a top and bottom plate, formed of pieces of sheet iron, abutting end to end, and connected by narrow strips riveted to them over the joints. These plates were 2 ft.  $11\frac{1}{2}$  in. wide. They were  $6\frac{1}{2}$  in. apart, and connected by two vertical side plates and five interior division plates, with which they were strongly joined by angle irons, riveted to the division plates, and to the top and bottom plates where they joined. Each cell, between two division plates and the top and bottom plates, was nearly 6 in. wide. The sides of the tube were made of plates of sheet iron similarly connected; their depth was 3 ft.  $6\frac{1}{4}$  in. A strip of angle iron, bent to a curved shape, and running from the bottom of each end of the tube to the top just below the cellular part, was riveted to each side to give it stiffness. Besides this, precautions were finally taken to stiffen the tube by diagonal braces within it. The bottom of the tube was formed of sheets, abutting end to end, and secured to each other like the top plates; a continuous joint, running the entire length of the tube along the centre line of the bottom, was secured by a continuous strip of iron on the under side, riveted to the plates on each side of the joint. The entire width of the bottom was 2 ft. 11 in.

The sheet iron composing the top cellular portion was 0.147 in. thick; that of the sides 0.099 in. thick. The bottom of the tube at the final experiments, to a distance of 20 ft. on each side of the centre, was composed of two thicknesses of sheet iron, each 0.25 in. thick, the joints being secured by strips above and below them, riveted to the sheets; the remainder, to the end of the tube, was formed of sheets 0.156 in. thick.

The total area of sheets composing the top cellular portion was 24.024 in., that of the bottom plates at the centre portion, 22.450 in.

The general dimensions of the tube were one sixth those of the proposed structure. Its weight at the final experiment, 13,020 lbs.

The experiments, as already stated, were conducted with a view to obtain an equality between the resistances of the parts strained by compression and those extended; with this object, at the end of each experiment, the parts torn asunder at the bottom were replaced by additional pieces of increased strength.

The following table exhibits the results of the final experiments:—

No. of Experiments.	Weight in lbs.	Deflection in inches.
1.....	20,006.....	0.55
2.....	35,776.....	0.78
3.....	48,878.....	1.12
4.....	62,274.....	1.48
5.....	77,534.....	1.78
6.....	92,299.....	2.12
7.....	103,350.....	2.38
8.....	114,660.....	2.70
9.....	132,209.....	3.05
10.....	138,060.....	3.23
11.....	143,742.....	3.40
12.....	148,443.....	3.58
13.....	153,027.....	3.70
14.....	157,728.....	3.78
15.....	161,886.....	3.88
16.....	164,741.....	3.98
17.....	167,614.....	4.10
18.....	171,144.....	4.23
19.....	173,912.....	4.33
20.....	177,088.....	4.47
21.....	180,017.....	4.55
22.....	183,779.....	4.62
23.....	186,477.....	4.72
24.....	189,170.....	4.81
25.....	192,892.....	

The tube broke with the weight in the 25th experiment; the cellular top yielding by puckering at about 2 feet from the point where the weight was applied. The bottom and sides remained uninjured.

The ultimate deflection was 4.89 in.

**645. Britannia Tubular Bridge.** Nothing further than a succinct description of this marvel of engineering will be attempted here, and only with a view of showing the arrangement of the parts for the attainment of the proposed end

It differs in its general structure from the model tube, chiefly in having the bottom formed like the top, of rectangular cells, and in the means taken for giving stiffness to the sides.

The total distance spanned by the bridge is 1,489 ft. This is divided into four bays, the two in the centre being each 460 ft., and the one at each end 230 ft. each.

The tube is 1,524 ft. long. Its bearing on the centre pier is 45 ft.; that on the two intermediate 32 ft.; and that on each abutment 17 ft. 6 in. The height of the tube at the centre pier is 30 ft.; at the intermediate piers 27 ft.; and at the ends 23 ft. This gives to the top of the tube the shape of a parabolic curve.

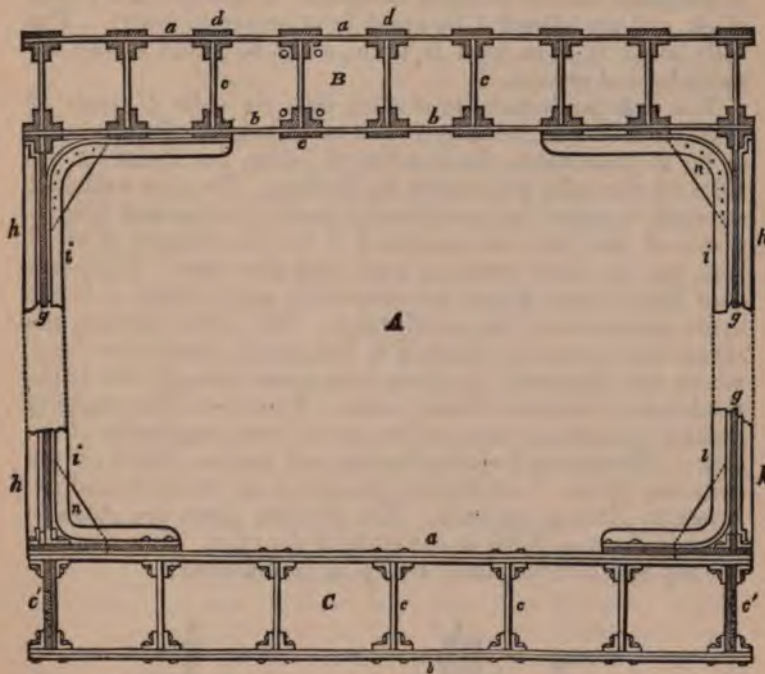

Fig. 188—Represents a vertical cross-section of the Britannia Bridge.

- A, interior of bridge.
- B, cells of top cellular beam.
- C, cells of bottom cellular beam.
- a, top plates of top and bottom beams.
- b, bottom plates of top and bottom beams.
- c, division plates of top and bottom beams.
- d and e, strips riveted over the joints of top and bottom plates.
- g, angle irons riveted to a, b, and c.
- h, plates of sides of the tube A.
- i, exterior T irons riveted over vertical joints of g.
- l, interior T irons riveted over vertical joints of g, and extending beyond the second cell of the top beam, and beyond the first of the bottom beam.
- n, triangular pieces on each side of l, and riveted to them.

The cellular top (Fig. 188) is divided into eight cells *B*, by division plates *c*, connected with the top *a*, and bottom *b*, by angle irons *o*, riveted to the plates connected. The different sheets composing the plates *a* and *b* abut end to end lengthwise the tube; and the joints are secured by the strips *d* and *e*, riveted to the sheets by rivets that pass through the interior angle irons.

The sheets of which this portion is composed are each 6 ft. long, and 1 ft. 9 in. wide; those at the centre of the tube are  $\frac{1}{8}$ ths of an inch thick: they decrease in thickness towards the piers, where they are  $\frac{1}{16}$ ths of an inch thick. The division plates are of the same thickness at the centre, and decrease in the same manner towards the piers. The rivets are 1 inch thick, and are placed 3 in. apart from centre to centre. The cells are 1 ft. 9 in. by 1 ft. 9 in., so as to admit a man for painting and repairs.

The cellular bottom is divided into six cells *C*, each of which is 2 ft. 4 in. wide by 1 ft. 9 in. in height. To diminish, as far as practicable, the number of joints, the sheets for the sides of the cells were made 12 ft. long. To give sufficient strength to resist the great tensile strain, the top and bottom plates of this part are composed of two thicknesses of sheet iron, the one layer breaking joint with the other. The joints over the division plates are secured by angle irons *o*, in the same manner as in the cellular top. The joints between the sheets are secured by sheets 2 ft. 8 in. long placed over them, which are fastened by rivets that pass through the triple thickness of sheets at these points. The rivets, for attaining greater strength at these points, are in lines lengthwise of the cell. The sheets forming the top and bottom plates of the cells are  $\frac{1}{8}$ ths of an inch at the centre of the tube, and decrease to  $\frac{1}{16}$ ths at the ends. The division plates are  $\frac{1}{8}$ ths in the middle, and  $\frac{1}{16}$ ths at the ends of the tube. The rivets of the top and bottom plates are  $1\frac{1}{2}$  in. in diameter.

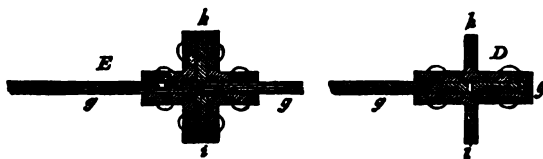

Fig. 169—Represents a horizontal cross-section of the T irons and side plates.  
*D*, cross-section near centre of bridge.  
*E*, cross-section near the piers.  
*g*, plates of the sides.  
*A*, exterior T irons.  
*a*, interior T irons.

The sides of the tube (Fig. 188) between the cellular top and bottom are formed of sheets *g*, 2 ft. wide; the lengths of which are so arranged that there are alternately three and four plates in each panel, the sheets of each panel abutting end to end, and forming a continuous vertical joint between the adjacent panels. These vertical joints are secured by strips of iron, *h* and *i*, of the  $\tau$  cross-section, placed over each side of the joint, and clamping the sheets of the adjacent panels between them. The  $\tau$  irons within and without are firmly riveted together with 1-inch rivets, placed at 3 in. between their centres. Over the joints, between the ends of the sheets in each panel, pieces of sheet iron are placed on each side, and connected by rivets. The sheets of the panels at the centre of the tube are  $\frac{3}{8}$ ths of an inch thick; they increase to  $\frac{1}{2}$ ths to within about 10 ft. of the piers, where their thickness is again increased: and the  $\tau$  irons are here also increased in thickness, being composed of a strip of thick sheet iron, clamped between strips of angle iron which extend from the top to the bottom of the joints. The object of this increase of thickness, in the panels and  $\tau$  irons at the piers, is to give sufficient rigidity and strength to resist the crushing strain at these points.

The  $\tau$  irons on the interior are bent at top and bottom, and extended as far as the third cell from the sides at top, and to the second at bottom. The projecting rib of each in the angles is clamped between two pieces, *n*, of sheet iron, to which it is secured by rivets, to give greater stiffness at the angles of the tube.

The arrangement of the ordinary  $\tau$  irons and sheets of the panels is shown in cross-section by *D*, Fig. 189; and that of the like parts near the piers by *E*, same Fig.

For the purpose of giving greater stiffness to the bottom, and to secure fastenings for the wooden cross sleepers that support the longitudinal beams on which the rails lie, cross plates of sheet iron, half an inch thick, and 10 in. in depth, are laid on the bottom of the tube, from side to side, at every fourth rib of the  $\tau$  iron, or 6 ft. apart. These cross plates are secured to the bottom by angle iron, and are riveted also to the  $\tau$  iron.

The tube is firmly fixed to the central pier, but at the intermediate piers and the abutments it rests upon saddles supported on rollers and balls, to allow of the play from contraction and expansion by changes of temperature.

The following tabular statements give the details of the dimensions, weights, etc., of the Britannia Bridge.



	Feet.	Plates	Angle iron	T iron.	Rivet iron.	Cast-iron.	Total
		tons.	tons.	tons.	tons.	tons.	tons.
Total length of each tube .....	1534						
" " of tubes for each line.....	3048						
Greatest span of bay.....	460						
Height of tubes at the middle .....	30						
" " intermediate piers .....	27						
" " ends.....	23						
Extreme width of tubes.....	14½						
Number of rivets in one tube.....	862,000						
Computed weight of tube 274 ft. long.....		450	109	70	60		688
" " 3 tubes 274 ft. long.....		1350	327	210	180		2067
" " 1 tube 473 ft. long.....		965	188	139	108		1400
" " 3 tubes 473 ft. long.....		2895	564	417	324		4200
" " 1 tube over pier 83 ft. long.....		64	26	10	7		107
" " 3 tubes over pier 83 ft. long.....		64	26	10	7		107
Frames and beams.....						2000	2000
Total weight.....		5788	1240	866	686	2000	10,579

**646. Formula for reducing the Breaking Weight of Wrought Iron Tubes.**

- Representing by A, the total area in inches of the cross-section of the metal.
- " " d, the total depth in inches of the tube.
- " " l, the length in inches between the points of support.
- " " C, a constant to be determined by experiment.
- " " W, the breaking weight in tons.

Then the relations between these elements, in tubes of cylindrical, elliptical and rectangular cross-section, will be expressed by

$$W = C \frac{A d}{l}$$

The mean value for C for cylindrical tubes, deduced from several experiments, was found to be 13.03; that for elliptical tubes, 15.3; and that for rectangular tubes, 21.5.

**647. Victoria Bridge.** This bridge is located near Montreal. It is a tubular bridge, a cross-section of which is shown in Fig. 190. It is the largest bridge of its kind in existence. It consists of twenty-four *openings* of 242 feet each, and a central span of 330 feet, and the total length of the tube, including the width of the abutments, is 6,538. The embankment forming the approach at the Montreal end is 1,200 feet long, and at the south end it is 800 feet, making a total length, including the approaches, of nearly 8,000 feet.

The centre span is level, but each side of the centre the bridge falls on a grade of 40 feet per mile.

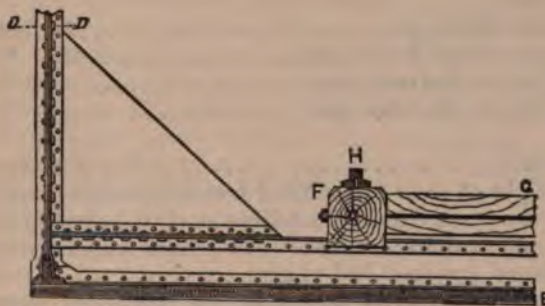

Fig. 190—Victoria Bridge.  
 Web plates and top plates at centre of tube.  
 A, the bar 6" x 9".75  
 B, web plate.  
 C C, cover plates.  
 D, top plates.  
 E, bottom plates.  
 F, heavy wooden beams on which rail H rests.  
 G, cross timber to connect beams F.

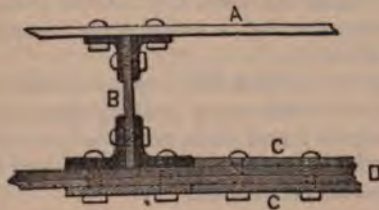

Fig. 190 A—Is an enlarged view of a part of one of the upper cells. The letters apply to the same parts as in the preceding Figure.  
 A is the top plate.  
 D shows two continuous plates, and C C, two joint plates.

Each tube covers two openings, being fixed in the centre, and free to expand or contract on the adjacent piers. They are 16 feet wide and 19 feet deep at their ends, and gradually

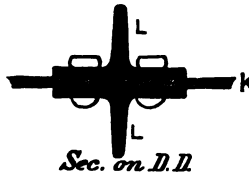

Fig. 190 B—Is a section on the line D D of Fig. 190.  
K is a vertical side plate.  
L L are angle irons which are riveted to the side plates.

Sec. on D. D.



Fig. 190 C—Section of the bottom plates B of Fig. 190. There are three continuous plates and four joint plates.

increase in depth to the middle, where they are 16 feet wide by 21 feet 8 inches deep. The total length of each of these double tubes is,

On the centre pier.....	16 feet.
Two openings in the clear.....	484 "
Resting on the east pier.....	8 "
Resting on the west pier.....	8 "

Total..... 516 feet.

The weight of each tube of 516 feet is about 644 tons. At each end are seven expansion rollers, each 6 inches in diameter, upon which the tubes rest. The rollers which are turned rest on planed cast-iron bed plates.

The centre pier is 24 feet wide, the remaining ones each 16 feet wide at the top.

The work of laying the foundation was begun in 1854, and the centre tube was put in place in March, 1859.

The scaffolding for the centre tube rested on the ice in the river, which began to move the day after the tube was put in place. From a record which had been kept of the breaking up of the ice, it was presumed that it would remain sound several days longer than it did.

The foundations were made on the solid rock by means of coffer-dams. Two kinds were used, one a floating dam, and the other a permanent crib-work; and each possessed certain advantages over the other which was peculiar to itself and to the objects which were to be accomplished.

## VII.

### SUSPENSION BRIDGES.

648. The use of flexible materials, as cordage and the like, to form a roadway over chasms and narrow water-courses, dates from a very early period; and structures of this character were probably among the first rude attempts of ingenuity, before the arts of the carpenter and mason were sufficiently advanced to be made subservient to the same ends. The idea of a suspended roadway, in its simplest form, is one that would naturally present itself to the mind, and its consequent construction would demand only obvious means and but little mechanical contrivance; but the step from this stage to the one in which such structures are now found, supposes a very advanced state both of science and of its application to the industrial arts, and we accordingly find that bridge architecture, under every other guise, was brought to a high degree of perfection before the suspension bridge, as this structure is now understood, was attempted.

With the exception of some isolated cases which, but in the material employed, differed little from the first rude structures, no recorded attempt had been made to reduce to systematic rules the means of suspending a roadway now in use, until about the year 1801, when a patent was taken out in this country for the purpose, by Mr. Finlay, in which the manner of hanging the chain supports, and suspending the roadway from it, are specifically laid down, differing, in no very material point, from the practice of the present day in this branch of bridge architecture. Since then, a number of structures of this character have been erected both in the United States and in Europe, and, in some instances, valleys and water-courses have been spanned by them under circumstances which would have baffled the engineer's art in the employment of any other means.

A suspension bridge consists of the supports, termed *piers*, from which the suspension chains are hung; of the anchoring masses, termed the *abutments*, to which the ends of the suspension chains are attached; of the suspension chains, termed the *main chains*, from which the roadway is suspended; of the vertical rods, or chains, termed the *suspending-chains*, etc., which connect the roadway with the main chains; and of the roadway.

649. **Bays.** The natural water-way may be divided into

any number of equal-sized bays, depending on local circumstances, and the comparative cost of high or low piers, and that of the main chains, and the suspending-rods.

A bridge with a single bay of considerable width presents a bolder and more monumental character, and its stability, all other things being equal, is greater, the amplitude from undulations caused by a movable load being less than one of several bays.

650. A chain or rope, when fastened at each extremity to fixed points of support, will, from the action of gravity, assume the form of a catenary in a state of equilibrium, whether the two extremities be on the same or different levels. The relative height of the fixed supports may therefore be made to conform to the locality.

651. The ratio of the versed sine of the arc to its chord, or span, will also depend, for the most part, on local circumstances and the object of the suspended structure. The wider the span, or chord, for the same versed sine, the greater will be the tension along the curve, and the more strength will therefore be required in all the parts of the cable. The reverse will obtain for an increase of versed sine for the same span; but there will be an increase in the length of the curve.

652. The chains may either be attached at the extremities of the curve to the fixed supports, or piers; or they may rest upon them (Figs. 191, 192), being fixed into anchoring masses

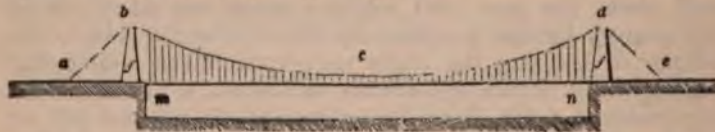

Fig. 191—Represents a chain arch  $a b c d e$ , resting upon two piers  $f f$ , and anchored at the points  $a$  and  $e$ , from which a horizontal beam  $m n$  is suspended by vertical chains, or rods.



Fig. 192—Represents the manner in which the system may be arranged when a single pier is placed between the extreme points of the bearing.

or abutments, at some distance beyond the piers. Local circumstances will determine which of the two methods will be the more suitable. The latter is generally adopted, particularly if the piers require to be high, since the strain upon them from the tension might, from the leverage, cause rup-

ture in the pier near the bottom, and because, moreover, it remedies in some degree the inconveniences arising from variations of tension caused either by a movable load or changes of temperature. Piers of wood, or of cast iron, movable around a joint at their base, have been used instead of fixed piers, with the object of remedying the same inconveniences.

653. When the chains pass over the piers and are anchored at some distance beyond them, they may rest either upon saddle-pieces of cast iron, or upon pulleys placed on the piers.

654. The position of the anchoring points will depend upon local circumstances. The two branches of the chain may either make equal angles with the axis of the pier, thus assuming the same curvature on each side of it, or else the extremity of the chain may be anchored at a point nearer to the base of the pier. In the former case the resultant of the tensions and weights will be vertical and in the direction of the axis of the pier, in the latter it will be oblique to the axis, and should pass so far within the base that the material will be secure from crushing. When the cable is secured to a saddle, and the saddle is free to move horizontally on the top of the pier, the resultant forces would still be vertical if there were no frictional resistance to the movement of the saddle. In all cases, whether the inclinations of the cable on the opposite sides of the pier are equal or not, the frictional resistance under the saddle when it is moving will cause a horizontal force tending to overturn the pier.

655. The anchoring points are usually masses of masonry of a suitable form to resist the strain to which they are subjected. They may be placed either above or below the surface of the ground, as the locality may demand. The kind of resistance offered by them to the tension on the chain will depend upon the position of the chain. If the two branches of the chain make equal angles with the axis of the pier, the resistance offered by the abutments will depend mainly upon the strength of the material of which they are formed. If the branches of the chain make unequal angles with the axis of the pier, the branch fixed to the anchoring mass is usually deflected in a vertical direction, and so secured that the weight of the abutment may act in resisting the tension on the chain. In this plan fixed pulleys placed on very firm supports will be required at the point of deflection of the chain to resist the pressure arising from the tension at these points.

Whenever it is practicable the abutment and pier should be

suitably connected to increase the resistance offered by the former.

The connection between the chains and abutments should be so arranged that the parts can be readily examined. The chains at these points are sometimes imbedded in a paste of fat lime to preserve them from oxidation.

656. The chains may be placed either above or below the structure to be supported. The former gives a system of more stability than the latter, owing to the position of the centre of gravity, but it usually requires high piers, and the chain cannot generally be so well arranged as in the latter to subserve the required purposes. The curves may consist of one or more chains. Several are usually preferred to a single one, as for the same amount of metal they offer more resistance, can be more accurately manufactured, are less liable to accidents, and can be more easily put up and replaced than a single chain. The chains of the curve may be placed either side by side, or above each other, according to circumstances.

657. The cables may be formed of chains, of wire cables, or of bands of hoop iron. Each of these methods has found its respective advocates among engineers. Those who prefer wire cables to chains urge that the latter are more liable to accidents than the former, that their strength is less uniform and less in proportion to their weight than that of wire cables, that iron bars are more liable to contain concealed defects than wire, that the proofs to which chains are subjected may increase without, in all cases, exposing these defects, and that the construction and putting up of chains is more expensive and difficult than for wire cables. The opponents of wire cables state that they are open to the same objections as those urged against chains, that they offer a greater amount of surface to oxidation than the same volume of bar iron would, and that no precaution can prevent the moisture from penetrating into a wire cable and causing rapid oxidation.

That in this, as in all like discussions, an exaggerated degree of importance should have been attached to the objections urged on each side was but natural. Experience, however, derived from existing works, has shown that each method may be applied with safety to structures of the boldest character, and that wherever failures have been met with in either method, they were attributable to those faults of workmanship, or to defects in the material used, which can hardly be anticipated and avoided in any novel application of a like character. Time alone can definitively decide

upon the comparative merits of the two methods, and how far either of them may be used with advantage in the place of structures of more rigid materials.

658. The chains of the cables may be formed of round, square, or flat bars. Chains of flat bars have been most generally used. These are formed in long links which are connected by short plates and bolts. Each link consists of several bars of the same length, each of which is perforated with a hole at each end to receive the connecting bolts. The bars of each link are placed side by side, and the links are connected by the plates which form a short link, and the bolts.

The links of the portions of the chain which rest upon the piers may either be bent, or else be made shorter than the others to accommodate the chain to the curved form of the surface on which it rests.

659. The vertical suspension bars may be either of round or square bars. They are usually made with one or more articulations, to admit of their yielding with less strain to the bar to any motion of vibration or of oscillation. They may be suspended from the connecting bolts of the links, but the preferable method is to attach them to a suitable saddle-piece which is fitted to the top of the chain and thus distributes the strain upon the bar more uniformly over the bolts and links. The lower end of the bar is suitably arranged to connect it with the part suspended from it.

660. The wire cables are composed of wires laid side by side, which are brought to a cylindrical shape and confined by a spiral wrapping of wire. To form the cable several equal-sized ropes, or yarns, are first made. This may be done by cutting all the wires of the length required for the yarn, or by uniting end to end the requisite number of wires for the yarn, and then winding them around two pieces of wrought or of cast iron, of a horse-shoe shape, with a suitable gorge to receive the wires, which are placed as far asunder as the required length of the yarn. The yarn is firmly attached at its two ends to the iron pieces, or *cruppers*, and the wires are temporarily confined at intermediate points by a spiral lashing of wire. Whichever of the two methods be adopted, great care must be taken to give to every wire of the yarn the same degree of tension by a suitable mechanism. The cable is completed after the yarns are placed upon the piers and secured to the anchoring ropes or chains; for this purpose the temporary lashings of the yarns are undone, and all the yarns are united and brought to a cylindrical shape and secured throughout the extent of the cable, to within a



short distance of each pier, by a continuous spiral lashing of wire.

The part of the cable which rests upon the pier is not bound with wire, but is spread over the saddle-piece with a uniform thickness.

661. The suspension ropes are formed in the same way as the cables; they are usually arranged with a loop at each end, formed around an iron crupper, to connect them with the cables, to which they are attached, and to the parts of the structure suspended from them by suitable saddle-pieces.

662. To secure the cables from oxidation the iron wires are coated with varnish before they are made into yarns, and after the cables are completed they are either coated with the usual paints for securing iron from the effects of moisture, or else covered with some impermeable material.

663. **Piers.** These are commonly masses of masonry in the shape of pillars, or columns, that rest on a common foundation, and are usually connected at the top. The form given to the pier, when of stone, will depend in some respects on the locality. Generally it is that of the architectural monument known as the *Triumphal Arch*; an arched opening being formed in the centre of the mass for the roadway, and sometimes two others of smaller dimensions, on each side of the main one, for approaches to the footpaths of the bridge.

Piers of a columnar, or of an obelisk form, have in some instances been tried. They have generally been found to be wanting in stiffness, being subject to vibrations from the action of the chains upon them, which in turn, from the reciprocal action upon the chains, tends very much to increase the amplitude of the vibrations of the latter. These effects have been observed to be the more sensible as the columnar piers are the higher and more slender.

Cast-iron piers, in the form of columns connected at top by an entablature, have been tried with success, as also have been columnar piers of the same material so arranged, with a joint at their base, that they can receive a pendulous motion at top to accommodate any increase of tension upon either branch of the chain resting on them.

The dimensions of piers will depend upon their height and the strain upon them. When built of stone, the masonry should be very carefully constructed of large blocks well bonded, and tied by metal cramps. The height of the piers will depend mostly on the locality. When of the usual forms, they should at least be high enough to admit the passage of vehicles under the arched way of the road.

**664. Abutments.** The forms and dimensions of the abutments will depend upon the manner in which they may be connected with the chains. When the locality will admit of the chains being anchored without deflecting them vertically, the abutments may be formed of any heavy mass of rough masonry, which, from its weight, and the manner in which it is imbedded, have sufficient strength to resist the tension in the direction of the chain. If it is found necessary to deflect the chains vertically to secure a good anchoring point, it will also generally be necessary to build a mass of masonry of an arched form at the point where the deflection takes place, which, to present sufficient strength to resist the pressure caused by the resultant of the tension on the two branches of the chain, should be made of heavy blocks of cut stone well bonded. If the abutments are not too far from the foundations of the piers, it will be well to connect the two, in order to give additional resistance to the anchoring points.

**665. Main Chains, etc.** The suspending curves, or arches, may be made of chains formed of *flat or round iron*, or may consist of *wire cables* constructed in the usual manner.

The main chains of the earlier suspension bridges were formed of long links of round iron made in the usual way; but, independently of the greater expense of these chains, they were found to be liable to defects of welding, and the links, when long, were apt to become misshapen under a great strain, and required to be stayed to preserve their form. Chains formed of long links of flat bars, usually connected by shorter ones, as coupling links, have on these accounts superseded those of the ordinary oval-shaped links.

The breadth of the chains has generally been made uniform, but in some bridges erected in England by Mr. Dredge, the chains are made to increase uniformly in breadth, by increasing the number of bars in a link, from the centre to the points of suspension. In addition to this change in the form of the main chains, Mr. Dredge places the suspending chains in a vertical plane parallel to the axis of the bridge, but obliquely to the horizon, inclining each way from the points of suspension towards the centre of the curve. This system has never come into general use. At the present day nearly all cables of suspension bridges are made of wire.

Some of the links of the main chains should be arranged with adjusting screws, or with keys, to bring the chains to the proper degree of curvature when set up.

The chains may either be attached to, or pass over a movable cast-iron saddle, seated on rollers on the top of the piers,

so that it will allow of sufficient horizontal displacement to permit the chains to accommodate themselves to the effects of a movable load on the roadway. The same ends may be attained by attaching the chains to a pendulum bar suspended from the top of the pier.

The chains are firmly connected with the abutments, by being attached to anchoring masses of cast iron, arranged in a suitable manner to receive and secure the ends of the chains, which are carefully imbedded in the masonry of the abutments. These points, when under ground, should be so placed that they can be visited and examined from time to time.

**666. Suspending-Chains.** The suspending-rods, or chains, should be attached to such points of the main chains and the roadway-bearers, as to distribute the load uniformly over the main chains, and to prevent their being broken or twisted off by the oscillations of the bridge from winds, or movable loads. They should be connected by suitably-arranged articulations, with a saddle piece bearing upon the back of the main chain, and at bottom with the stirrup that embraces the roadway-bearers.

The suspending-chains are usually hung vertically. In some recent bridges they have been inclined inward to give more stiffness to the system.

**667. Roadway.** Transversal roadway-bearers are attached to the suspending-chains, upon which a flooring of timber is laid for the roadway. The roadway-bearers, in some instances, have been made of wrought iron, but timber is now generally preferred for these pieces. Diagonal ties of wrought iron are placed horizontally between the roadway-bearers to brace the frame-work.

The parapet may be formed in the usual style either of wrought iron, or of timber, or of a combination of cast iron and timber. Timber alone, or in combination with cast iron, is now preferred for the parapets; as observation has shown that the stiffness given to the roadway by a strongly-trussed timber parapet limits the amplitude of the undulations caused by violent winds, and secures the structure from danger.

In some of the more recent suspension bridges, a trussed frame, similar to the parapet, has been continued below the level of the roadway, for the purpose of giving greater security to the structure against the action of high winds.

When the roadway is above the chains, any requisite number of single chains may be placed for its support. Frames formed of vertical beams of timber, or of columns of cast

iron united by diagonal braces, rest upon the chains, and support the roadway-bearers placed either transversely or longitudinally.

**668. Vibrations.** The undulatory or vibratory motions of suspension bridges, caused by the action of high winds, or movable loads, should be reduced to the smallest practicable amount, by a suitable arrangement of bracing for the roadway-timbers and parapet, and by chain-stays attached to the roadway and to the basements of the piers, or to fixed points on the banks whenever they can be obtained.

Calculation and experience show that the vibrations caused by a movable load decrease in amplitude as the span increases, and, for the same span, as the versed sine decreases. The heavier the roadway, also, all other things being the same, the smaller will be the amplitude of the vibrations caused by a movable load, and the less will be their effect in changing the form of the bridge.

The vibrations caused by a movable load seldom affect the bridge in a hurtful degree, owing to the elasticity of the system, unless they recur periodically, as in the passage of a body of soldiers with a cadenced march. Serious accidents have been occasioned in this way; also by the passage of cattle, and by the sudden rush of a crowd from one side of the bridge to the other. Injuries of this character can only be guarded against by a proper system of police regulations.

Chain-stays may either be attached to some point of the roadway and to fixed points beneath it, or else they may be in the form of a reversed curve below the roadway. The former is the more efficacious, but it causes the bridge to bend in a disagreeable manner at the point where the stay is attached, when the action of a movable load causes the main chains to rise. The more oblique the stays, the longer, more expensive, and less effective they become. Stays in the form of a reversed curve preserve better the shape of the roadway under the action of a movable load, but they are less effective in preventing vibrations than the simple stay. Neither of these methods is very serviceable, except in narrow spans. In wide spans, variations of temperature cause considerable changes in the length of the stays, which makes them act unequally upon the roadway; this is particularly the case with the reversed curve. Both kinds should be arranged with adjusting screws, to accommodate their length to the more extreme variations of temperature.

Engineers at present generally agree that the most efficacious means of limiting the amplitude, and the consequent

injurious effects of undulations, consists in a strong combination of the roadway-timbers and flooring, stiffened by a trussed parapet of timber above the roadway, and in some cases in extending the framework of the parapet below it. These combinations present, in appearance and reality, two or more open-built beams, as circumstances may demand, placed parallel to each other, and strongly connected and braced by the framework of the roadway, which are supported at intermediate points by the suspending-rods or chains. The method of placing the roadway-framing at the central line of the open-built beams, presents the advantage of introducing vertical diagonal braces, or ties, between the beams beneath the roadway-frame. The main objections to these combinations is the increased tension thrown upon the chains from the greater weight of the framework. This increase of tension, however, provided it be kept within proper limits, so far from being injurious, adds to the stability and security of the bridge, both from the effects of undulations and of vibrations from shocks.

As a farther security to the stability of the structure, the framework of the roadway should be firmly attached at the two extremities to the basements of the piers.

**669. Preservative Means.** To preserve the chains from oxidation on the surface, and from rain or dews which may lodge in the articulations, they should receive several coats of minium, or of some other preparation impervious to water, and this should be renewed from time to time, and the forms of all the parts should be the most suitable to allow the free escape of moisture.

Wires for cables can be preserved from oxidation, until they are made into ropes, by keeping them immersed in some alkaline solution. Before making them into ropes, they should be dipped several times in boiling linseed oil, prepared by previously boiling it with a small portion of litharge and lampblack. The cables should receive a thick coating of the same preparation before they are put up, and finally be painted with white-lead paint, both as a preservative means, and to show any incipient oxidation, as the rust will be detected by its discoloring the paint.

**670. Proofs of Suspension Bridges.** From the many grave accidents, accompanied by serious loss of life, which have taken place in suspension bridges, it is highly desirable that some trial-proof should be made before opening such bridges to the public, and that, moreover, strict police regulations should be adopted and enforced, with respect to them.

to guard against the recurrence of such disasters as have several times taken place in England, from the assemblage of a crowd upon the bridge. In France, and on the continent generally, where one of the important duties of the public police is to watch over the safety of life, under such circumstances, regulations of this character are rigidly enforced. The trial-proof enacted in France for suspension bridges, before they are thrown open for travel, is about 40 lbs. to each superficial foot of roadway in addition to the permanent weight of the bridge. This proof is at first reduced to one-half, in order not to injure the masonry of the points of support during the green condition of the mortar. It is made by distributing over the road surface any convenient weighty material, as bricks, pigs of iron, bags of earth, etc. Besides this after-trial, each element of the main chains should be subjected to a special proof to prevent the introduction of unsound parts into the system. This precaution will not be necessary for the wire of a cable, as the process of drawing alone is a good test. Some of the coils tested will be a guarantee for the whole.

From experiments made at Geneva, by Colonel Dufour, one of the earliest and most successful constructors of suspension bridges on the Continent, it appears that wrought bar iron can sustain, without danger of rupture, a shock arising from a weight of 44 lbs., raised to a height of 3.28 feet on each .0015dths of an inch of cross-section, when the bar is strained by a weight equal to one-third of its breaking weight; and he concludes that no apprehension need be entertained of injury to a bridge from shocks caused by the ordinary transit upon it, which has been subjected to the usual trial of a dead weight; and that the safety, in this respect, is the greater as the bridge is longer, since the elasticity of the system is the best preservative from accidents due to such causes. Mr. Whoeler, an engineer in Germany, concluded, after a long series of carefully conducted experiments, that good wrought iron would sustain any number of continuous shocks, provided that it was in no case strained more than 10,000 pounds per square inch of section.

**67L. Durability.** Time is the true test of the durability of the structures under consideration. So far as experience goes there seems to be no reason to assign less durability to suspension than to cast-iron or even stone bridges, if their repairs and the proper means of preserving them from decay are attended to. Doubts have been expressed as to the durability of wire cables, but these seem to have been set at rest

by the trials and examinations to which a bridge of this kind erected by Colonel Dufour, at Geneva, was subjected by him after twenty years' service. It was found that the undulations were greater than when the bridge was first erected, owing to the shrinking of the roadway-frame; but the main cables, and suspending-ropes, even at the loops in contact with the timber, proved to be as sound as when first put up, and free from oxidation; and the whole bridge stood another very severe proof without injury.

The following succinct descriptions of the principal elements of some of the most celebrated suspension bridges of chains, and wire cables, of remarkable span, are taken from various published accounts.

**672. Bridge over the Tweed near Berwick.** This is the first large suspension bridge erected in Great Britain. It was constructed upon the plans of *Capt. Brown*, who took out a patent for the principles of its construction.

Span..... 449 feet.

Versed sine..... 30 "

Number of main-chains 12, six being placed on each side of the roadway, in three ranges of two chains each, above each other.

The chains are composed of long links of round iron, 2 inches in diameter, and are 15 feet long. They are connected by coupling-links of round iron,  $1\frac{1}{4}$  inch diameter, and about 7 inches long, by means of coupling bolts.

The roadway is borne by suspending-rods of round iron, which are attached alternately to the three ranges of chains. The roadway-bearers are of timber, and are laid upon longitudinal bars of wrought iron, which are attached to the suspension-rods.

**673. Menai Bridge,** erected after the designs of *Mr. Telford*. Opened in 1826.

Span..... 579.8 feet.

Versed sine..... 43 "

Number of main-chains 16, arranged in sets of 4 each, vertically above each other.

Number of bars in each link, 5.

Length of links, 10 feet.

Breadth of each bar,  $3\frac{1}{2}$  inches; depth, 1 inch.

Coupling-links, 16 inches long, 8 inches broad, and 1 inch deep.

Coupling-bolts, 3 inches in diameter.

Total area of cross-section of the main-chain, 260 square inches

The main-chains are fastened to their abutments by anchoring-bolts 9 feet long and 6 inches in diameter, which are secured in cast-iron grooves. The abutments, which are underground, and reached by suitable tunnels, are the solid rock.

Upon the tops of the piers are cast-iron saddles, upon which the main-chains rest. The base of the saddle, which is fitted with grooves to receive them, rests upon iron rollers placed on a convex cylindrical bed of cast iron, shaped like the bottom of the base of the saddle, to admit of a slight displacement of the chains from movable loads or changes of temperature.

The roadway is divided into two carriage-ways, each 12 feet wide, and a footpath 4 feet wide between them. The roadway-framing consists of 444 wrought-iron roadway-bearers,  $3\frac{1}{2}$  inches deep and  $\frac{1}{4}$  inch thick, which are supported at the centre points of each of the carriage-ways by an inverted truss, consisting of two bent iron ties which support a vertical bar placed under the roadway-bars at the points just mentioned. The platform of the roadway is formed of two thicknesses of plank. The first, 3 inches thick, is laid on the roadway-bearers and fastened to them. This is covered by a coating of patent felt soaked in boiling tar. The second is two inches thick and spiked to the first.

The roadway is suspended by articulated rods attached to stirrups on the roadway-bearers and to the coupling-bolts of the main-chains.

The piers are 152 feet high above the high-water level. They have an arched opening leading to the roadway, and the masses on the sides of the arch are built hollow, with a cross-tie partition wall between the exterior main walls.

The parapet is of wrought-iron vertical and parallel bars connected by a network.

This bridge was seriously injured by a violent gale, which gave so great an oscillation to the main-chains that they were dashed against each other, and the rivet-heads of the bolts were broken off. To provide against similar accidents, a framework of cast-iron tubes, connected by diagonal pieces, was fastened at intervals between the main-chains, by cross-ties of wrought-iron rods, which passed through the tubes, and were firmly connected with the exterior chains. Subsequently to this addition, a number of strong timber roadway-bearers were fastened at intervals to those of iron, as the iron roadway-bearers were found to have been bent, and in some instances broken, by the undulatory motion of the bridge in heavy gales.



The total suspending weight of this bridge, including the main-chains, roadway, and all accessories, is stated at 648 tons  $15\frac{1}{2}$  cwt.

674. The Fribourg Bridge of wire thrown across the valley of the Sarine, opposite Fribourg, was erected in 1832, by *M. Chaley*, a French engineer.

Span.....	870.32 feet.
Versed sine.....	63.26 "

There are 4 main cables, 2 on each side of the road, of the same elevation, and about  $1\frac{1}{2}$  inch asunder. Each cable is composed of 1056 wires, each about 0.118 inch in diameter, which are firmly connected and brought to cylindrical shape by a spiral wire wrapping. The diameter of the cable varies from 5 to  $5\frac{1}{2}$  inches. The cables pass over 3 fixed pulleys on the top of the piers, upon which they are spread out without ligatures, and are each attached to two other cables of half their diameter, which are anchored at some distance from the piers, in vertical pits, passing over a fixed pulley where they enter the mouth of the pit.

The suspending-ropes are of wire a size smaller than that used for the cables. Their diameter is nearly one inch. They are formed with a loop at each end, fastened around a crupper-shaped piece of cast iron, that forms an eye to connect the rope with the hook of the stirrup affixed to the roadway-bearers, and to a saddle-piece of wrought iron, for each rope, that rests on the two main cables.

The roadway-bearers are of timber, being deeper in the centre than at the two ends, the top surface being curved to conform to a slight transverse curvature given to the surface of the carriage-way; they are placed about 5 feet between their centre lines, every fourth one projecting about 3 feet beyond the ends of the others, to receive an oblique wrought-iron stay to maintain the parapet in its vertical position. The carriage-way, which is about  $15\frac{1}{2}$  feet wide, is formed of two thicknesses of plank. The foot-paths, which are 6 feet wide, are raised above the surface of the carriage-way, and rest upon longitudinal beams of large dimensions, the inner one of which is firmly secured to the roadway-bearers by stirrups which embrace them, and the exterior one is fastened to the same pieces by long screw-bolts, which pass through the top rail of the parapet. The roadway has a slight curvature from the centre to the two extremities, along the axis, the centre point being from 18 inches to about 3 feet higher than the ends, according to the variations of temperature. The main

cables at the centre are brought down nearly in contact with the roadway-timbers.

The parapet is an open-built beam, consisting of a top rail, the bottom rail being the longitudinal exterior beam of the footpath, and of diagonal pieces which are mortised into the two rails; the whole being secured by the iron bolts that pass through the roadway-bearers and the top rail. This combination of the parapet with the inclination towards the axis of the roadway given to the suspending-ropes, gives great stiffness to the roadway and counteracts both lateral oscillations and longitudinal undulations.

The piers consist of two pillars of solid masonry, about 66 feet high above the level of the roadway, which are united, at about 33 feet above the same level, by a full centre arch, having a span of nearly 20 feet, and which forms the top of the gateway leading to the bridge.

**675. Hungerford and Lambeth Bridge**, erected over the Thames, upon the plans of Mr. Brunel.

This bridge, designed for foot-passengers only, has the widest span of any chain bridge erected up to this period.

Span.....	676½ feet.
Versed sine.....	50 "

The main chains are 4 in number, two being placed on each side of the bridge, one above the other. These chains are formed entirely of long links of flat bars; the links near the centre of the curve having alternately ten and eleven bars in each, and those near the piers alternately eleven and twelve bars. The bars are 24 feet long, 7 inches in depth, and 1 inch thick. They are connected by coupling-bolts, 4½ inches in diameter, which are secured at each end by cast-iron nuts, 8 inches in diameter, and 2½ inches thick. The extremity of each chain is connected with a cast-iron saddle-piece, by bolts which pass through the vertical ribs of the saddle-piece, of which there are 15. The bottom of the saddle rests on 50 friction-rollers, which are laid on a firm horizontal bed of cast-iron. The saddle can move 18 inches horizontally, either way from the centre, and thus compensate for any inequality of strain on the main chains, either from a load, or from variations of temperature.

The side main-chains are attached in like manner to the saddle, and anchored at the other extremity in an abutment of brickwork. The anchorage (Fig. 193) is arranged by passing the chains through a strong cast-iron plate, and securing the ends of the bars by keys. The anchoring-plate is retained in

its place by two strong cast-iron beams, against which the strain upon the plate is thrown.

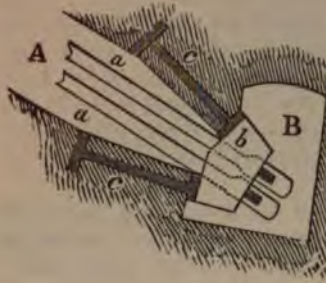

Fig. 193—Shows the manner in which the side main-chains are anchored.

A, inclined shaft for the chains leading to the arched chamber B of the anchorage.

a, a, two main-chains, passed through the cast-iron holding-plate b and fastened behind it by keys.

c, c, cross sections of the cast-iron girders which retain b.

The suspending-rods (Fig. 194) are connected with both the

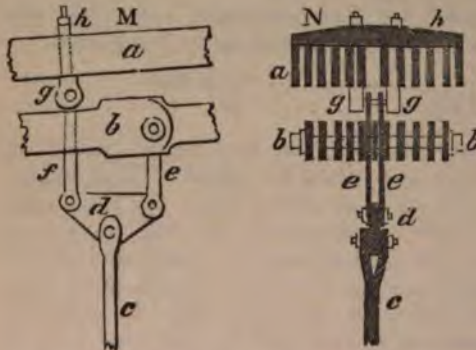

Fig. 194—Shows an elevation M and cross section N of the connection between the main-chains and suspending-rods.

a, a, upper main-chain.

b, b, joint of lower main chain.

c, suspending-rod with a forked head to receive the plate d, hung by stirrups e and f, respectively, to the coupling-bolt of the links and to the two bolts g, fastened to the saddle h on top of the upper main-chain.

upper and lower main-chains; to the upper by a saddle-piece and bolts, and to the coupling-bolt of the lower by an arrangement of articulations, which allows an easy play to the rods; at the bottom (Fig. 195) they are connected by a joint with a bolt that fastens firmly the roadway-timbers.

The roadway-timbers consist of a strong longitudinal bottom beam, upon which the roadway-bearers are notched; these last pieces are in pairs, the two being so far apart that the bolts connecting with the suspending-rods by a forked head can pass between them; the flooring-plank is laid upon the roadway-bearers; and a top longitudinal beam, which forms the bottom rail of the parapet, is secured to the bottom beam by the connecting bolt. Wrought-iron diagonal ties are placed horizon

tally below the flooring, to brace the whole of the timbers beneath.

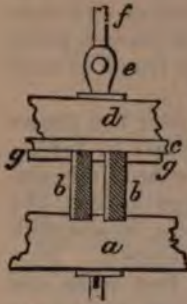

Fig. 195—Shows an elevation of the roadway-timbers.

*a*, bottom longitudinal beam.

*b, b*, roadway-bearers in pairs.

*c*, platform.

*d*, top longitudinal beam forming the bottom rail of the parapet.

*e*, bolt, with a forked head to receive the end of the suspending rod, which is keyed beneath and secures the beams, etc.

*g*, wrought-iron horizontal diagonal ties.

The roadway is 14 feet wide. It slopes from the centre point along the axis to the extremities, being 4 feet higher in the centre than at the two last points.

The piers are in the form of towers, resembling the Italian belfry. They are of brick, 80 feet high, and so constructed and combined with the top saddles, that they have to sustain no other strain than the vertical pressure from the main-chains.

The whole weight of the structure, with an additional load of 100 lbs. per square foot of the roadway, would throw about 1,000 tons on each pier. The tension on the chains from this load is calculated at about 1,480 tons; while the strain which they can bear without impairing their strength is about 5,000 tons.

**676. Monongahela Wire Bridge.** This bridge, erected at Pittsburgh, Penn., upon plans, and under the superintendence of the late Mr. Roebling, has 8 bays, varying between 188 and 190 feet in width. It is one of the more recent of these structures in the United States.

The roadway of each bay is supported by two wire cables, of  $4\frac{1}{2}$  inches in diameter, and by diagonal stays of wire rope, attached to the same point of suspension as the cables, and connecting with different points of the roadway-timbers. The ends of the cables of each bay are attached to pendulum-bars, by means of two oblique arms, which are united by joints to the pendulum-bars. These bars are suspended from the top of 4 cast-iron columns, inclining inwards at top, which are there firmly united to each other; and, at bottom, anchored to the top of a stone pier built up to the level of the roadway timbers. The side columns of each frame are connected throughout by an open lozenge-work of cast

iron. The front columns have a like connection, leaving a sufficient height of passage-way for foot-passengers.

The framework of 4 columns on each side is firmly connected at the top by cast-iron beams, in the form of an entablature. A carriage-way is left between the two frames, and a footpath between the two columns forming the fronts of each frame.

The points of suspension of the cables are over the centre line of the footpaths; and the cables are inclined so far inward that the centre point of the curve is attached just outside of the carriage-way. The suspending-ropes have a like inward inclination, the object in both cases being to add stiffness to the system, and diminish lateral oscillations.

The roadway consists of a carriage-way 22 feet wide, and two footpaths each 5 feet wide. The roadway-bearers are transversal beams in pairs, 35 feet long, 15 inches deep, and  $4\frac{1}{2}$  inches wide. They are attached to the suspending-ropes. The flooring consists of  $2\frac{1}{2}$ -inch plank, laid longitudinally over the entire roadway-surface; and of a second thickness of  $2\frac{1}{2}$ -inch oak plank laid transversely over the carriage-way.

The parapet, which is on the principle of Town's lattice, extends so far below the roadway-bearers that they rest and are notched on the lowest chord of the lattice. A second chord embraces them on top, and finally a third chord completes the lattice at the top. The object of adopting this form of parapet was to increase the resistance of the roadway to undulations.

**677. Niagara Railroad and Highway Suspension Bridge.** This remarkable structure, like the Aqueduct suspension bridge at Pittsburgh, was constructed by Roebling; and for boldness of plan, and skill in the execution of its details, is every way worthy of the professional ability of this distinguished engineer.

Designed to afford a passage-way over the Niagara river, both for railroad and common road traffic, it consists essentially of two platforms (Fig. 196), one above the other, and about fifteen feet apart; the upper serving as the railroad track, and the lower for ordinary vehicles; the two being connected by a lattice girder on each side; and the whole bridge-frame being suspended from four main wire cables, two of which are connected with the upper platform, and two with the lower, by suspension-rods and wire ropes attached to the roadway-bearers, or joists of the platforms.

Each platform consists of a series of roadway-bearers in pairs; the lower covered by two thicknesses of flooring-plank,

the upper by one thickness; the portion of the latter immediately under the railroad track having a thickness of four inches, and the remainder on each side but two inches.

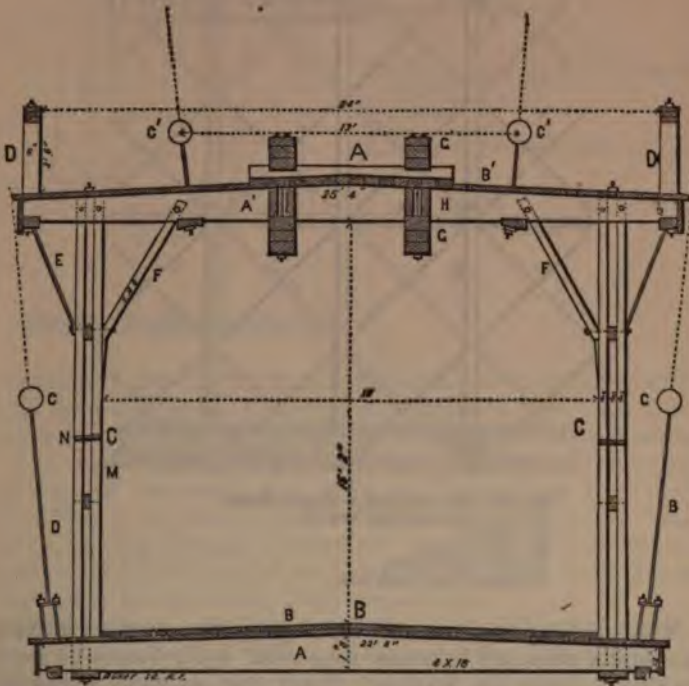

Fig. 196—Cross section of Niagara Bridge.

- |                                    |   |
|------------------------------------|---|
| A, railway track and beams.        | C, lower main cables.                           |
| B, lower platform for common road. | C', upper main cables.                          |
| C, Diagonal truss.                 | D, suspension ropes.                            |
| D, parapet.                        | E, wrought-iron braces.                         |
| A, lower roadway bearers.          | F, wooden braces.                               |
| A', upper roadway bearers.         | G, beams of longitudinal railway bearers.       |
| B, lower flooring.                 | H, longitudinal braces between roadway bearers. |
| B', upper flooring.                | N, horizontal rail between posts.               |

The lattice-girders consist of vertical posts in pairs, the ends of which are clamped between the roadway-bearers; and of diagonal wrought-iron rods with screws at each end, which pass through cast-iron plates fastened above the roadway-bearers of the upper platform, and below those of the lower, and are brought to a proper bearing by nuts on each end. A horizontal rail of timber is placed between the posts of the lattice at their middle points to prevent flexure.

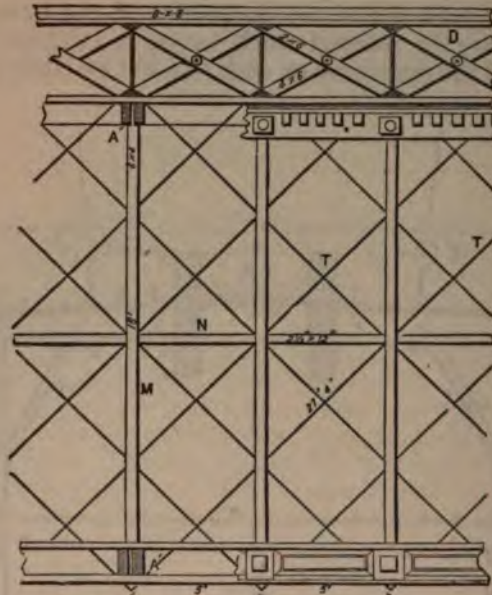

Fig. 197—Side elevation of Niagara Bridge.

A', A', ends of roadway bearers.  
 D, parapet.  
 M, posts in pairs.  
 N, rail between posts.  
 T, diagonal iron brace rods.

The roadway-bearers and flooring of the upper platform are solidly clamped between four solid built beams or girders; two above the flooring, which rest on cross supports; and two, corresponding to those above, below the roadway-bearers; the upper and lower corresponding beams, with longitudinal braces in pairs between the roadway-bearers and resting on the lower beams, being firmly connected by screw-bolts. The rails are laid upon the top beams.

A strong parapet, on the plan of Howe's truss, is placed on each side of the upper platform.

Wrought-iron and wooden braces connect the posts and the two platforms.

The piers (Fig. 198) consist of four obelisk-shaped pillars, which are sixty feet high; the base of each being a square of fifteen feet sides; and the top one of eight feet sides. The pedestal of each pillar is a square of about seventeen feet side at top, and having a batir of one foot vertically to one horizontally, or  $\frac{1}{12}$ , on each of its faces. The height of the

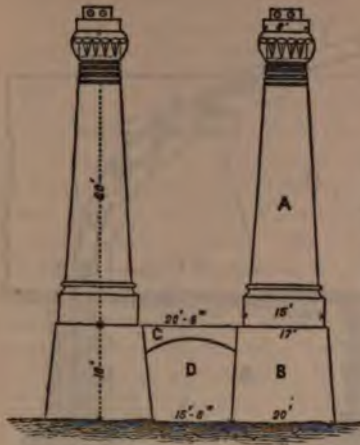

Fig. 198—End elevation of piers and connecting arch of bridge.  
 A, shaft of the pier.  
 B, pedestal.  
 C, connecting arch.  
 D, arched way for common road.

pedestals on the United States side of the river being twenty-eight feet, and on the Canadian side eighteen feet. An archway below the level of the railroad connects the two pedestals.

The main cables pass over saddles placed on rollers, on the tops of the piers, and they are fastened at their ends (Fig. 199) to chains formed of links of wrought-iron bars, which, passing through abutments of masonry, and down into shafts made into the solid rock below, are there each firmly attached to an anchoring-plate of cast iron.

Besides the usual suspending-rods of the bridge, a number of wire ropes, termed *over-floor stays*, connect the portions of the upper platform adjacent to the piers with the saddles at the top of the piers; and the lower platform is in like manner connected with the rocky banks of the river by a number of like stays. The object of both being to resist the action of high winds upon the platform, and to give the bridge more rigidity.

Each of the main cables is formed of seven smaller ones or *strands*. The whole bound together in the usual manner by a wire wrapping. Each strand contains 520 wires in its cross-section, sixty of which make an area of one square inch.

The main cables to which the roadway-bearers of the upper platform are attached are deflected laterally towards the axis of the bridge, and thus limit the range of lateral oscillations. This provision, the lattice structure of the sides and the parapet, the over and under floor stays, the deep longitudinal girders of the railway track, the slight camber or longi-



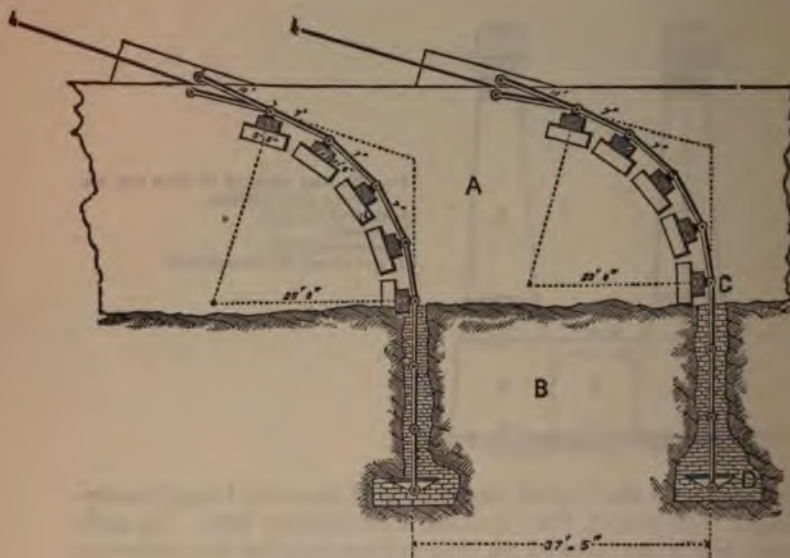

Fig. 199.—Side view of anchor-chain.  
 A, masonry of buttress.  
 B, natural rock bed.  
 C, shaft and masonry for chains.  
 D, anchoring-plate.

tudinal curvature from the ends of the bridge to the centre, and its own weight, give to the whole structure that degree of rigidity and stability which are its marked characteristics, as contrasted with suspension bridges usually.

Some of the principal dimensions of the means of suspension are given in the following statement:

Span of both cables between axis of piers,  $821\frac{1}{2}$  feet.

Versed sine of cables of lower platform, 64 feet.

Versed sine of cables of upper platform, 54 feet.

Diameter of each cable, 10 inches.

Area of cross-section of each cable, 60.4 square inches.

Area of cross-section of upper links of anchor-chains, 372 square inches.

Ultimate strength of anchor-chains, 11,904 tons.

Number of wires in the four cables, 14,560.

Average strength of one wire, 1,648 lbs.

Ultimate strength of the four cables, 12,000 tons.

Permanent weight borne by the cables, 1,000 tons.

Length of anchor-chains, 66 feet.

Length of upper cables, 1,261 feet.

Length of cables, 3,460 feet.

Wire rope suspenders, 1,088.

Over-floor stays, 400.

Under-floor stays, on main span, 36.

Height of railway track above mean high water, 139 feet.

**678. East River Bridge.** The East River Bridge is the longest span suspension bridge erected up to this date. It forms a suspended highway connecting the cities of New York and Brooklyn. The terminus in New York city is on Park Row opposite the City Hall; and in Brooklyn is on Sands street between Fulton and Washington streets. The total length of the bridge and approaches is 5,989 feet, made up as follows: main span, 1,595 feet 6 inches between centres of towers; two land spans of 930 feet each; the New York approach, 1,562 feet 6 inches, and the Brooklyn approach, 971 feet. Since the completion of the bridge the New York approach has been improved by an extension of the platform over Park Row and Centre street to the City Hall square. The bridge proper consists of one river span and two land spans. The approaches are carried by massive brick arches faced with granite, except at street crossings; at these, iron bridges or brick arches are used. The spaces under these arches have been utilized for store and storage purposes.

The general grade of the bridge is three feet and three inches per hundred feet, rising from the termini to the centre; slight variations from this grade exist.

The width of the bridge is 85 feet from out to out, and it is divided into five spaces by six lines of steel trusses, the outer two being ten feet in height and the other four about 18 feet.

The outer spaces are in the clear 18 feet 9 inches, are covered with plank, and used exclusively by vehicle traffic.

The next two spaces are 12 feet 3 inches in the clear, and are used exclusively for railroad purposes. A single track is laid in each, and upon these are run trains propelled by an endless wire rope which always moves in one direction. The power station is located in Brooklyn, and the trains are run at a speed of ten and one-quarter miles per hour, the time of transit across the bridge and approach being about six minutes.

The central or fifth division of the bridge forms a promenade for foot travel 15 feet 3 inches in width. It is elevated 12 feet above the roadways, affording at the centre of the river span an unobstructed view up and down the river and of both cities. The roadway passes through the

towers at an elevation of 119 feet 3 inches, and at the centre of the river span is 135 feet above mean high water, and offers but slight obstruction to navigation.

The bridge is supported by four steel wire cables, each 15 $\frac{1}{2}$  inches in diameter, composed of galvanized steel wire, principally of No. 6 gauge, having a strength of 160,000 pounds per square inch of section.

This grand structure was devised, and work upon it superintended till his death, by John A. Roebling. It was completed by his son, Washington A. Roebling.

The total weight of the superstructure is	6,620	tons.
Weight of cables	3,460	“
Weight of suspenders, rails, flooring, etc.	4,600	“
Total	14,680	“

The passenger traffic on the cars is frequently taxed to its utmost capacity, and several plans for increasing its capacity have been proposed. A bill was recently introduced into the New York State legislature for authorizing the structure of another suspension bridge a short distance above the present one.

## VIII.

### MOVABLE BRIDGES.

679. The term *movable bridge* is commonly applied to a platform supported by a framework of timber or of cast iron, by means of which a communication can be formed or interrupted at pleasure between any two points of a fixed bridge, or over any narrow water-way. These bridges are generally denominated *draw-bridges*, but this term is now, for the most part, confined to those movable bridges which can be raised or lowered by means of a horizontal axis, placed either at one extremity of the platform, or at some intermediate point between the two ends, and a counterpoise which is so connected with the platform in either case, that the bridge can be easily manœuvred by a small power acting through the intermedium of some suitable mechanism applied to the counterpoise. The term *turning or swinging bridge* is used when the bridge is arranged to turn horizontally around a vertical axis placed at a point between its two ends, so that the parts on each side of the axis balance each other; and the term *rolling bridge* is applied when the bridge

resting upon rollers, can be shoved forward or backward horizontally, to open or interrupt the passage.

To the above may be added another class of movable bridges used for the same purpose, which consist of a platform supported by a boat, or other buoyant body, which can be placed in or withdrawn from the water-way as circumstances may require.

**680. Draw-Bridges.** When the horizontal axis of this description of bridge is placed at the extremity of the platform, the bridge is manœuvred by attaching a chain to the other extremity, which is connected with a counterpoise and a suitable mechanism, by which the slight additional power required for raising the bridge can be applied.

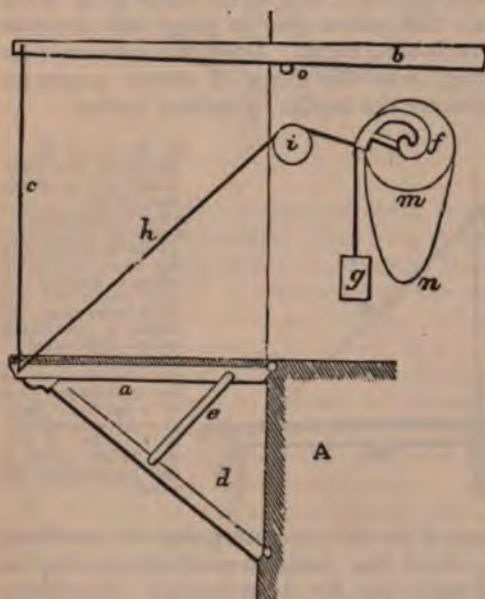

Fig. 200—Shows the manner of manœuvring a draw-bridge either by a framed lever, or by a counterpoise suspended from a spiral eccentric.

- A, abutment.  
*a*, section of the platform.  
*b*, framed lever.  
*c*, chain attached to the ends of the lever and the platform.  
*d*, strut movable around its lower end.  
*e*, bar with an articulation at each end that confines the strut to the platform.  
*f*, spiral eccentric connected with the counterpoise *g* by a chain passing over the gorge of the eccentric.  
*g*, chain for raising the bridge, one end of which is attached to the extremity of the platform, and the other to the axle of the eccentric.  
*h*, fixed pulley over which the chain *k* is passed.  
*i*, wheel fixed to the axle of the eccentric for the purpose of turning it by means of animal power applied to the endless chain *n*.

A number of ingenious contrivances have been put in practice for these purposes. They consist usually either of a counterpoise of invariable weight, connected with additional animal motive-power, which acts with constant intensity, but with a variable arm of lever; or of a counterpoise of variable weight, which is assisted by animal motive-power acting with an invariable arm of lever. In some cases the bridge is worked with a less complicated combination, by dispensing

with a counterpoise, and applying animal motive-power, of variable intensity, acting with a constant or a variable arm of lever.

Among the combinations of the first kind the most simple consists in placing a framed lever (Fig. 200) revolving on a horizontal axis above the platform. The anterior part of the frame is connected with the movable extremity of the platform by two chains. The posterior portion, which forms the counterpoise, has chains attached to it by which the lever can be worked by men.

When the locality does not admit of this arrangement, the chain attached to the movable end of the platform may be connected with a horizontal axle above the platform, to which is also attached a fixed eccentric of a spiral shape (Fig. 200), connected with a chain that passes over its gorge and sustains a counterpoise of invariable weight. Upon the same axle an ordinary wheel is hung, over the gorge of which passes an endless chain to manœuvre the bridge by animal power.

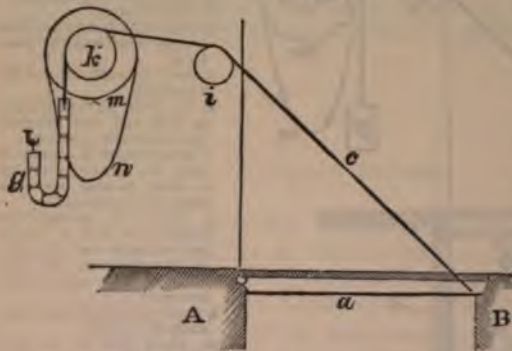

Fig. 201—Shows the arrangement of a draw-bridge with a variable counterpoise.

A and B, abutments.  
*g*, variable counterpoise formed of a chain with flat links, one end of which is attached to a fixed point, and the other to the chain *c* attached to the movable end of the platform.  
*4*, fixed pulley over which the chain *c* passes to the small wheel *k* fixed on a horizontal shaft, to which is also attached the wheel *m* and the endless chain *n* for manœuvring the bridge.

Of the combinations of variable counterpoises the mechanism of M. Poncelet, which has been successfully applied in many instances in France for the draw-bridges of military works, is one of the most simple in its arrangement and construction. The movable end of the platform (Fig. 201) is connected by a common chain, that passes over the gorge of a wheel hung upon a horizontal shaft above the platform, with another chain of variable breadth, formed of flat bar links, which forms the counterpoise. The chain counterpoise is attached at its other extremity to a fixed point in such a way, that when the platform ascends a portion of the weight of the chain is borne by this fixed point; and thus the weight of

the counterpoise decreases as the platform rises. The system is manoeuvred by an endless chain passed over the gorge of a wheel hung upon the horizontal shaft.

For light platforms a counterpoise may be dispensed with, and the bridge may be manoeuvred by connecting the chain attached to the movable end of the platform to a horizontal shaft, which is turned by the usual tooth-work combinations.

When the locality does not admit of manoeuvring the

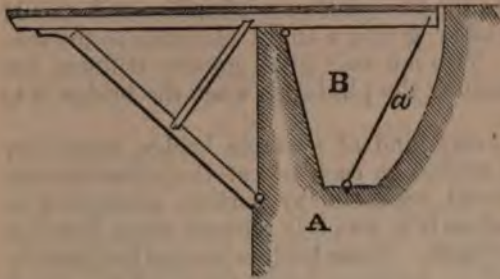

Fig. 202—Shows the arrangement of a draw-bridge where the counterpoise is formed by prolonging back the platform.

A, abutment.

B, well of a suitable form for manoeuvring the bridge.

a, chain-stay to keep the platform firm when the bridge is down.

bridge by a chain connected with some point above the framework, the platform (Fig. 202) is continued back, from two-thirds to three-fifths its length, from the face of the abutment, to form a counterpoise for the platform of the bridge. The horizontal axis of the bridge is placed near the face of the abutment, and a well of a suitable shape to receive the posterior portion of the platform that forms the counterpoise is formed behind the abutment.

The mechanism for working the bridge may consist of a chain and capstan below the platform-counterpoise, or of a suitable combination of tooth-work.

In bridges of a single platform, the movable extremity, when the bridge is lowered, rests on the opposite abutment, and no intermediate support will be required for the structure if the framework be of sufficient strength; but when a double bridge, consisting of two platforms, is used, the platforms (Fig. 200) should be supported near their movable ends, when the bridge is down, by struts movable around the joint by which they are connected with the face of the abutments. These struts are so connected with the bridge that they are detached from it and drawn up when it is raised, and fall back into their places, abutting against blocks near the movable end of the platform, when the bridge is down. By these arrangements the chains for working the bridge are relieved from a

portion of the strain when the bridge is down, and it is also rendered more firm.

When the counterpoise is formed by the rear part of the platform, additional security may be given to the bridge when down by attaching two chains beneath the platform, and securing them to anchoring-points at the bottom of the well. In some cases a heavy bar, fitted to staples beneath connected with the timbers of the platform, is used for the same purpose.

In double bridges the two platforms when lowered should abut against each other, giving a slight elevation to the centre of the bridge. This not only gives greater stiffness, but is favorable to detaching the platforms when the bridge is to be raised.

For draw, and every kind of movable bridge, temporary barriers should be erected on each side at the entrance upon the bridge, to prevent accidents by persons attempting to cross the bridge before it is properly secured when lowered.

**681. Turning-bridges.** These bridges revolve horizontally upon a vertical shaft or gudgeon below the platform, which is usually thrown far enough back from the face of the abutment to place the side of the bridge, when brought round, just within this face. The weights of the parts of the bridge around the shaft should balance each other.

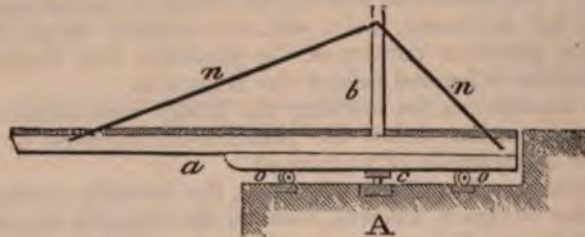

Fig. 203—Represents the arrangement of a turning-bridge.  
*a*, platform of the bridge.  
*b*, vertical posts to which the iron stays *n n* are attached.  
*c*, vertical shaft or gudgeon on which the bridge turns.  
*o o*, conical rollers.

To support and manœuvre the bridge (Fig. 203) a circular ring of iron, or *roller-way*, of less diameter than the breadth of the bridge, and concentric with the vertical shaft, is firmly imbedded in masonry. Fixed rollers, in the shape of truncated cones, are attached at equal distances apart to the framework of the platform beneath, and rest upon the roller-way.

The bridge is worked by a suitably arranged tooth-work, or by a chain and capstan. In some cases cast-iron balls, resting on a grooved roller-way, and fitting into one of corresponding shape fixed beneath the platform, have been used for manœuvring the bridge.

The ends of the bridge are cut in the shape of circular arcs to fit recesses of a corresponding form in the abutments, so arranged as not to impede the play of the bridge.

In double-turning bridges the two ends of the platforms which come together should be of a curved shape. The platforms should be sustained from beneath by struts, like those used for draw-bridges, which can be detached and drawn into recesses when the passage is interrupted; or else they may be arranged with a ball-and-socket joint at their lower extremity, so as to be brought round with the bridge. For the purpose of giving additional strength and security to the bridge, iron stays are, in some cases, attached on each side of the platform near the extremities, and connected with vertical posts placed in a line with the vertical shaft.

Turning-bridges may be made either of timber or of cast iron; the latter material is the more suitable, as admitting of more accuracy of workmanship, and not being liable to the derangements caused by the shrinking or warping of framework of timber.

**632. Swing Bridge at Providence, R. I.** The details of this bridge are worthy of special study. An account of it is published in the *London Engineering* for March 21st, 1873. Fig. 204 is an elevation of the bridge, and the right-hand half of Fig. 205 is a plan of the truss work under the roadway, and the left-hand half the plan of the roadway and truss work. Fig. 206 is a section of the turn-table for supporting the bridge. An essential part is the four compound radial arms, G G, F F, Fig. 206, the lower parts of which are of cast-iron compression members, and the upper parts of two wrought-iron rods each.

The whole structure rests upon a nest of conical rollers, I I (Fig. 206), upon which it turns as it moves about. There are several small wheels *b, b, b*, which are under the turn-table, and serve only to steady it in case it tends to tip in any direction.

The strains on the several members were computed under three hypotheses, viz.: 1st. The strains due to the weight of the truss only when the draw was open. These strains were assumed to be the same as when it was closed and unloaded, for no part of the weight of the bridge was supposed to be



Fig. 204.

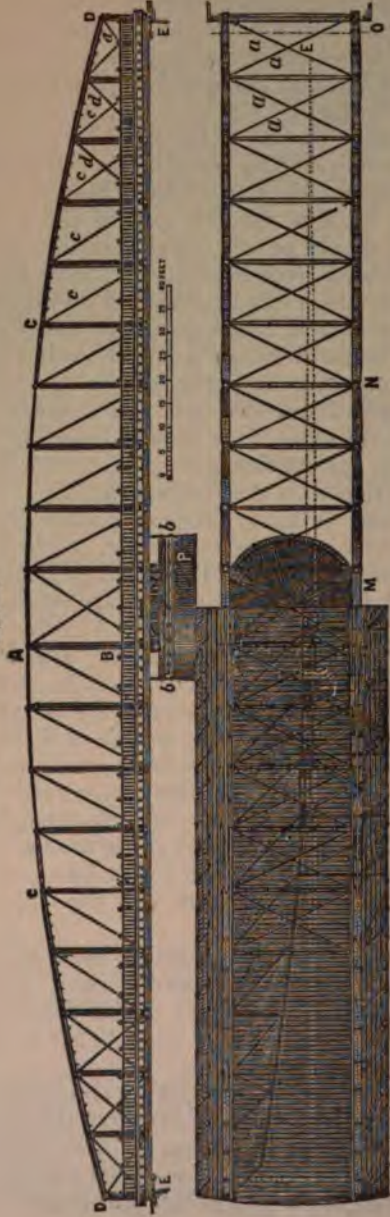
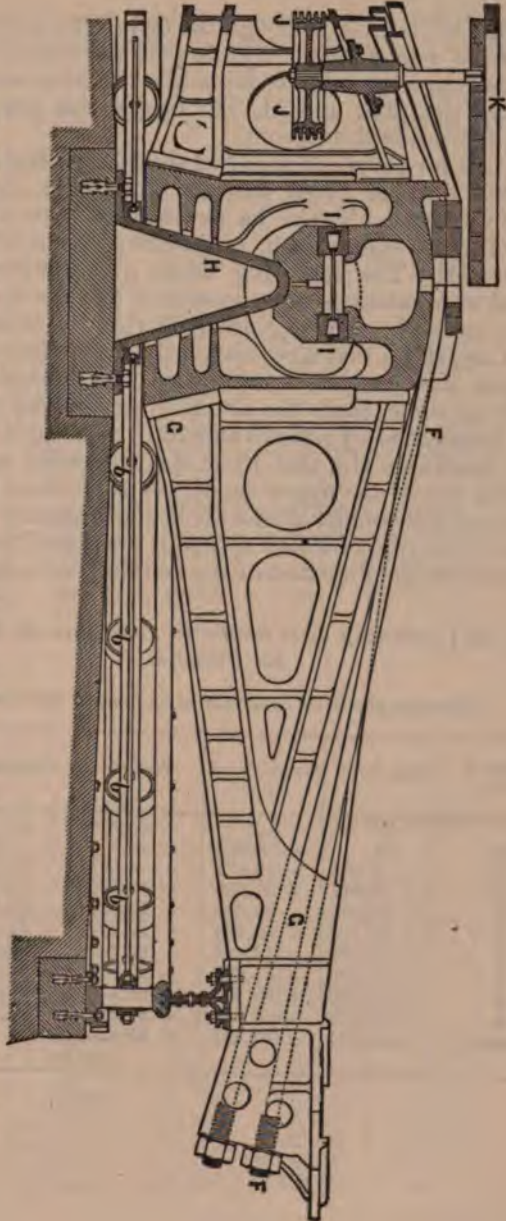

Fig. 205.

Fig. 204 and 205.—The elevation and plan of the swing bridge over Point Street, at Providence, Rhode Island. Total span 250 feet. Depth at the centre 35 feet, and at the ends 9 feet. The part A C of the upper chord is subjected to tension only, and is composed of tension bars only; but the part C D may be subjected to both tension and compression, and is made to resist both strains. The three end panels only require counter-ties. E is a pin for securing the bridge in place when it is closed. a, a, a, are tie rods after the plan of a Whipple Truss. The part M N is subjected to compression only, and the part N O to both tension and compression. c, c, c, are main tie rods; d, d, counter-tie rods, P, the foundation for the turn table, b, b, the seat for steady wheels.



**Fig. 306.**—Is the turn-table. *a, b, c, d, e, f, g, h, i, j* are rollers for guiding the turn-table to keep it from overturning. They serve to steady it. The whole weight rests upon a nest of conical rollers *I, I*, upon which the table turns.  
*H* is a central block for supporting the table.  
*G, G* is a cast-iron arm, which is supported at its outer end by the wrought-iron radial arms *P, P* (four in number). *J, J* is the wheel for opening the draw. A shaft extends from *J* upwards to the door *B*, to which a lever is attached. Two men can easily open and close the draw.

supported at its ends, although the ends were pinned to keep them from rising when only one part was loaded. 2d. One half was supposed to be loaded while the other end was held down by the pin; and 3d. The bridge was supposed to be loaded uniformly throughout.

The call for proposals specified that the rolling load should be 3,200 lbs. per lineal foot of the bridge, and that the wrought iron should not be strained in tension to exceed 12,000 lbs. per square inch, or in compression 8,000 lbs. per square inch. The following tables give the results of the original computations for the strains and the dimensions of the pieces used. The engineer, Charles McDonald, of New York City, states that a review of the computations after the structure was completed, confirmed the general results, although in some cases the actual strains exceed those previously determined by a small amount. Although the analysis shows (see Table II.), that there is compression on the fourth and fifth bay of the upper chord, yet there is no tendency to a strain on the counter-diagonals in those panels. The inclination of the upper chord acts as a brace and thus prevents any strain in the direction of the counter-tie in those panels.

TABLE No. I.—Showing Total Strains on Parts when the Bridge is Open, but Unloaded.

(The sign plus is for compression and minus for tension.)

Number of Bay.	Top Chord.	Bottom Chord.	Verticals.	Diagonals.	Counter-ties.
End	lb. nil.	lb. + 6,073	lb. nil	lb. — 8,427	lb. nil
2	— 6,223	+ 19,577	+ 4,407	— 20,900	“
3	— 19,941	+ 37,735	+ 13,532	— 30,868	“
4	— 38,263	+ 59,688	+ 22,565	— 40,800	
5	— 60,280	+ 85,759	+ 32,227	— 51,340	
6	— 86,300	+ 116,189	+ 42,702	— 62,600	
7	— 116,600	+ 151,625	+ 55,047	— 75,375	
8	— 151,860	+ 193,249	+ 68,463	— 90,350	
9	— 193,400	+ 242,624	+ 84,090	— 107,637	
Centre	— 242,624	+ 242,624	+ 98,625	nil	

TABLE NO. II.—Showing Total Strains on Parts with Bridge Closed and one-half fully Loaded, the Unloaded end being Latched.

Number of Bay.	Top Chord.	Bottom Chord.	Verticals.	Diagonals.	Counter-ties.
	lb.	lb.	lb.	lb.	lb.
Loaded end	+ 69,500	nil	+ 64,500	nil	- 81,080
2	+ 83,610	- 67,480	+ 21,500	nil	- 27,000
3	+ 83,110	- 69,800	nil	nil	nil
4	+ 69,977	- 41,600	+ 17,718	- 52,249	
5	+ 42,000	nil	+ 40,365	- 81,910	
6	nil	+ 53,800	+ 64,500	- 110,674	
7	- 54,000	+ 120,337	+ 92,690	- 141,580	
8	- 120,520	+ 201,326	+ 123,440	- 175,770	
9	- 201,480	+ 299,537	+ 158,187	- 214,100	
Centre	- 299,537	+ 304,868	{ + 193,500 }	- 60,560	
			{ + 160,010 }		
9	- 249,140	+ 304,868	+ 96,480	- 121,916	
8	- 201,954	+ 248,943	+ 79,520	- 103,670	
7	- 161,500	+ 201,637	+ 65,190	- 86,618	
6	- 126,120	+ 160,915	+ 51,800	- 73,141	
5	- 95,240	+ 125,360	+ 41,036	- 61,061	
4	- 67,713	+ 94,300	+ 30,984	- 51,000	
3	- 42,962	+ 66,778	+ 22,400	- 41,955	nil
2	- 20,600	+ 42,178	+ 14,500	- 34,240	nil
Unloaded end	nil	+ 20,098	nil	- 27,752	nil

TABLE NO. III.—Showing Total Strains on Parts with Bridge closed and fully Loaded.

Number of Bay.	Top Chord.	Bottom Chord.	Verticals.	Diagonals.	Counter-ties.
	lb.	lb.	lb.	lb.	lb.
End	+ 52,130	nil	+ 48,425	nil	- 60,810
2	+ 55,774	- 50,611	+ 10,500	nil	- 13,500
3	+ 55,100	- 34,940	nil	- 26,727	nil
4	+ 35,430	nil	+ 24,157	- 64,732	
5	nil	- 47,644	+ 48,425	- 94,383	
6	- 47,930	+ 107,600	+ 74,621	- 123,340	
7	- 108,000	+ 180,500	+ 104,633	- 155,073	
8	- 180,779	+ 268,200	+ 136,540	- 190,300	
9	- 268,400	+ 374,421	+ 172,803	- 231,560	
Centre	- 374,421	+ 374,420	+ 209,625	nil	

TABLE NO. IV.—Showing Dimensions of Principal Parts and their Effective Sectional Areas.

No. of Bay.	Top Chord.		Bottom Chord.		Verticals.		Diagonals.		Counter-ties.	
	Of what Composed.	Sectional Area, sq. in.	Of what Composed.	Sectional Area, sq. in.	Sectional Area, sq. in.	Of what Composed.	Sectional Area, sq. in.	Of what Composed.	Sectional Area, sq. in.	
End	Two 6 in. channel bars; $\frac{5}{8}$ in. cover plates.	12.11	Two 12 in. channel bars	17.6	10.0	Two bars, $1\frac{1}{2}$ in. x $1\frac{1}{2}$ in.	2.53	Two bars, $1\frac{1}{2}$ in. x $1\frac{1}{2}$ in.	6.57	
2	do.	14.11	do.	17.6	5.75	Two bars, $1\frac{7}{8}$ in. x $1\frac{7}{8}$ in.	2.83	One bar, $1\frac{1}{2}$ in. x $1\frac{1}{2}$ in.	2.64	
3	do.	14.11	do.	17.6	5.75	Two bars, $1\frac{1}{2}$ in. x $1\frac{1}{2}$ in.	3.78	One bar, $1\frac{1}{2}$ in. x $1\frac{1}{2}$ in.	1.0	
4	do.	12.11	do.	17.6	5.75	Two bars, $1\frac{1}{2}$ in. x $1\frac{1}{2}$ in.	5.28	none		
5	do.	12.11	do.	17.6	7.5	Two bars, $2\frac{1}{2}$ in. x $2\frac{1}{2}$ in.	8.0	"		
6	Three 4 in. x 1 in. bars, swelled.	9.75	Two 12 in. channel bars, $\frac{7}{8}$ in. cover plates	24.28	10.0	Four bars, $1\frac{1}{2}$ in. x $1\frac{1}{2}$ in.	10.56	"		
7	Four bars $1\frac{1}{2}$ in. x $1\frac{1}{2}$ in.	11.4	Two 12 in. channel bars, $\frac{5}{8}$ in. cover plates	30.96	13.8	Four bars, $1\frac{1}{2}$ in. x $1\frac{1}{2}$ in.	12.25	"		
8	Three bars, $2\frac{3}{8}$ in. x $2\frac{1}{8}$ in.	14.35	Four 12 in. channel bars, $\frac{7}{8}$ in. cover plates	41.88	17.0	Four bars, $1\frac{1}{2}$ in. x $1\frac{1}{2}$ in.	15.01	"		
9	Four bars, $2\frac{1}{2}$ in. x $2\frac{1}{8}$ in.	21.4	Four 12 in. channel bars, $\frac{5}{8}$ in. cover plates	54.69	22.25	Four bars, $2\frac{1}{2}$ in. x $2\frac{1}{2}$ in.	18.06	"		
Centre	Five bars, $2\frac{1}{2}$ in. x $2\frac{1}{8}$ in.	29.7	do.	54.69	26.3	Two bars, $2\frac{1}{2}$ in. x $2\frac{1}{2}$ in.	9.08	"		

**683. Rolling-bridges.** These bridges are placed upon fixed rollers, so that they can be moved forward or backward, to interrupt or open the communication across the water-way. The part of the bridge that rests upon the rollers, when the passage is closed, must form a counterpoise to the other. The mechanism usually employed for manœuvring these bridges consists of tooth-work, and may be so arranged that it can be worked by one or more persons standing on the bridge. Instead of fixed rollers turning on axles, iron balls, resting in a grooved roller-way, may be used, a similar roller-way being affixed to the framework beneath.

**684. Boat-bridge.** A movable bridge of this kind may be made by placing a platform to form a roadway upon a boat, or a water-tight box of a suitable shape. This bridge is placed in, or withdrawn from the water-way, as circumstances may require, a suitable recess or mooring being arranged for it near the water-way when it is left open.

A bridge of this character cannot be conveniently used in tidal waters, except at certain stages of the water. It may be employed with advantage on canals in positions where a fixed bridge could not be placed.

## IX.

### AQUEDUCT BRIDGES.

**685.** In aqueducts and aqueduct-bridges of masonry, for supplying reservoirs for the wants of a city, or for any other purpose, the volume of water conveyed being, generally speaking, small, the structure will present no peculiar difficulties beyond affording a water-tight channel. This may be made either of masonry, or of cast-iron pipes, according to the quantity of water to be delivered. If formed of masonry, the sides and bottom of the channel should be laid in the most careful manner with hydraulic cement, and the surface in contact with the water should receive a coating of the same material, particularly if the stone or brick used be of a porous nature. This part of the structure should not be commenced until the arches have been uncentred and the heavier parts of the structure have been carried up and have had time to settle. The interior spandrel-filling, to the level of the masonry which forms the bottom of the water-way, may either be formed of solid material, of good rubble laid in hydraulic cement, or of beton well settled in layers; or a system of interior walls, like those used in common bridges

for the support of the roadway, may be used in this case for the masonry of the water-way to rest on.

636. In canal aqueduct-bridges of masonry, as the volume of water required for the purposes of navigation is much greater than in the case of ordinary aqueducts, and as the structure has to be traversed by horses, every precaution should be taken to procure great solidity, and secure the work from accidents.

Segment arches of medium span will generally be found most suitable for works of this character. The section of the water-way is generally of a trapezoidal form, the bottom line being horizontal, and the two sides receiving a slight batir; its dimensions are usually restricted to allow the passage of a single boat at a time. On one side of the water-way a horse or *tow-path* is placed, and on the other a narrow footpath. The water-way should be faced with a hard cut-stone masonry, well bonded to secure it from damage from the passage of the boats. The space between the facing of the water-way, termed the *trunk* of the aqueduct, and the head-walls, is filled in with solid material, either of rubble or of beton.

A parapet-wall of the ordinary form and dimensions surmounts the tow and foot paths.

The approach to an aqueduct-bridge from a canal is made by gradually increasing the width of the trunk between the wings, which, for this purpose, usually receives a curved shape, and narrowing the water-way of the canal so as to form a convenient access to the aqueduct. Great care should be taken to form a perfectly water-tight junction between the two works.

687. When cast iron or timber is used for the trunk of an aqueduct-bridge, the abutments and piers should be built of stone. The trunk, which, if of cast iron, is formed of plates with flanches to connect them, or, if of timber, consists of one or two thicknesses of plank supported on the outside by a framing of scantling, may be supported by a bridge-frame of cast iron, or of timber, or be suspended from chains or wire cables.

The tow-path may be placed either within the water-way, or, as is most usually done, without. It generally consists of a simple flooring of plank laid on cross-joists supported from beneath by suitably-arranged framework.

## CHAPTER VI.

## ROOFS.

688. A Roof, in common language, is the covering over a structure, the chief object of which is to protect the building against the effects of snow and rain. It is composed of boards, shingles, slate, mastic, or other suitable materials.

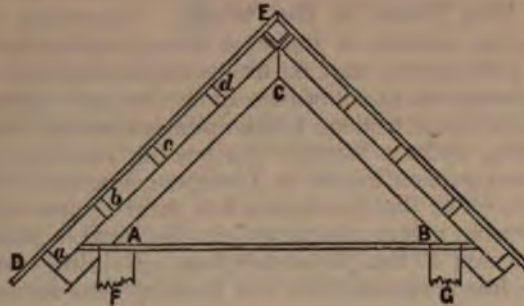

Fig. 207.

The inclined pieces AC, and BC, Fig. 207, which support the roof are called *rafters*. When the roof is light, the roof boards DE are placed directly upon the rafters, but when the rafters are far apart, say more than four feet, small pieces *a*, *b*, *c*, and *d*, called *purlins*,\* are placed across the rafters for the purpose of receiving the roof proper. AB is a tie, and F and G represent the ends of posts. The frame ABC is called a *roof truss*.

689. **Roof Trusses** have a great variety of forms, and differ greatly in the details of their construction. All the trusses which have been discussed in the preceding pages are suitable for this purpose in many cases. Some other forms are given in the following pages.

690. **General Data.** A roof truss is required to carry its own weight, the weight of the purlins, the weight of the

\* Purlin beams are sometimes placed under the rafters.



roof above them, the force of the wind, the weight of snow when there is any, and in some cases certain local or concentrated loads, such as floors, machinery, and the like, which are suspended from the roof trusses.

**691. The Weight of Snow.** Freshly fallen snow weighs from five to twelve lbs. per cubic foot, although snow which is saturated with water weighs much more. Some say that snow is equivalent to from  $\frac{1}{10}$  to  $\frac{1}{8}$  of its depth in water, while others say that it may be equivalent to  $\frac{1}{4}$  its depth of water.

European engineers consider that six lbs. per square foot is sufficient for snow, and eight lbs. for the pressure of the wind, making fourteen lbs. for both. Trautwine thinks that not less than twenty lbs. should be allowed in the United States.

**692. The Force of the Wind.** According to Mr. Smeaton, the pressure of the wind directly against a flat surface in a hurricane may be 32 lbs. per square foot. Tredgold recommends an allowance of 40 lbs. per square foot. A gauge in Girard College broke under a strain of 42 lbs. per square foot, whilst a tornado was passing near by. During the severest gale on record at Liverpool, England, there was a pressure of 42 lbs. per square foot directly upon a flat surface. During a very violent gale in Scotland, a wind-gauge once indicated 45 lbs. per square foot. Buildings which are more or less protected will not be subjected to such high pressures.

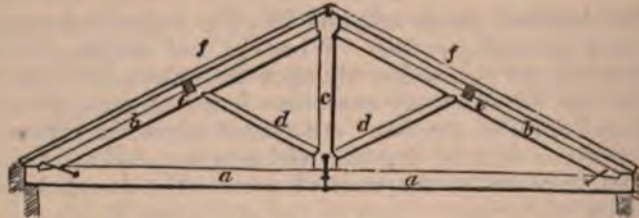

Fig. 208—Represents a roof truss for medium spans.

a, tie-beam of truss.

b, b, principal rafters framed into tie-beam and the king post c, and confined at their foot by an iron strap.

d, d, struts.

e, e, purlins supporting the common rafters f, f.

**693.** The truss of a roof, for ordinary bearings, consists (Fig. 208) of a horizontal beam termed the *tie-beam*, with which the inclined beams, termed the *principal rafters*, are connected by suitable joints. The principal rafters may

either abut against each other at the top or *ridge*, or against a king post. Inclined struts are in some cases placed between the principal rafters and king post, with which they are connected by suitable joints.

For wider bearings the short rafters (Fig. 209) abut against a straining beam at the top. Queen posts connect these pieces with the tie-beam. A king post connects the straining beam with the top of the short rafters; and struts are placed at suitable points between the rafters and king and queen posts.

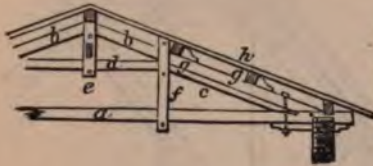

Fig. 209—Represents a roof truss for wide spans.  
*a*, tie-beam.  
*b*, *b'*, principal rafters,  
*c*, short rafters abutting against the straining beam *d*.  
*e* and *f*, king and queen posts in pairs.  
*g*, *g'*, pairs supporting common rafters *h*.

In each of these combinations the weight of the roof covering and the frames is supported by the points of support. The principal rafters are subjected to cross and longitudinal strains, arising from the weight of the roof covering at *d* from their reciprocal action on each other. These strains are transmitted to the tie-beam, causing a strain of tension upon it. The struts resist the cross strain upon the rafters and prevent them from sagging; and the king and queen posts prevent the tie and straining beams from sagging and give points of support to the struts. The short rafters and straining beam form points of support which resist the cross strain on the principal rafters, and support the strain on the queen posts.

**694. Ties and Braces for Detached Frames.** When a series of frames concur to one end, as, for example, the main beams of a bridge, the trusses of a roof, ribs of a centre, etc., they require to be tied together and stiffened by other beams to prevent any displacement and warping of the frames. For this purpose beams are placed in a horizontal position and notched upon each frame at suitable points to connect the whole together; while others are placed crossing each other, in a diagonal direction, between each pair of frames, with which they are united by suitable joints, to stiffen the frames and prevent them from yielding to any lateral effort. Both the ties and the diagonal braces may be either of single beams, or of beams in pairs, so arranged as to embrace between them the part of the frames with which they are connected.

695. **Iron Roof Trusses.** Frames of iron for roofs have been made either entirely of wrought iron, or of a combination of wrought and cast iron, or of these two last materials combined with timber. The combinations for the trusses of roofs of iron are in all respects the same as in those for timber trusses. The parts of the truss subjected to a cross strain, or to one of compression, are arranged to give the most suit-

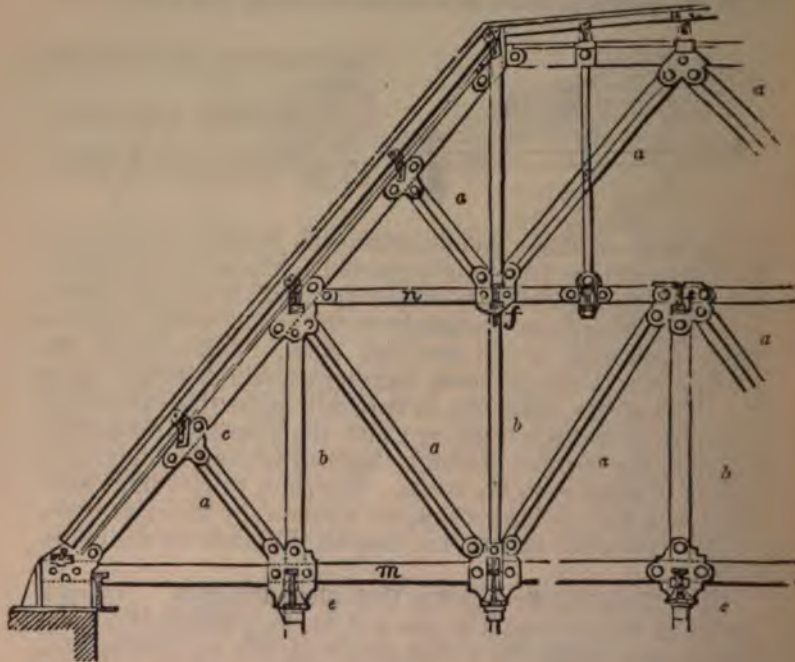

Fig. 210—Represents the half of a truss for the same building composed of wrought and cast iron.  
*a, a*, feathered struts of cast-iron.  
*b, b*, suspension bars in pairs.  
*m, n*, tie and straining bars.  
*e, e*, and *f, f*, cross sections of beams resting in the cast-iron sockets connected with the suspension bars.

able forms for strength, and to adapt them to the object in view. The parts subjected to a strain of extension, as the tie-beam and king and queen posts, are made either of wrought iron or timber, as may be found best adapted to the particular end proposed.

The joints are in some cases arranged by inserting the ends

of the beams, or bars, in cast-iron sockets, or shoes of a suitable form; in others the beams are united by joints arranged like those for timber frames, the joints in all cases being secured by wrought-iron bolts and keys. (Figs. 210, 211 and 212.)

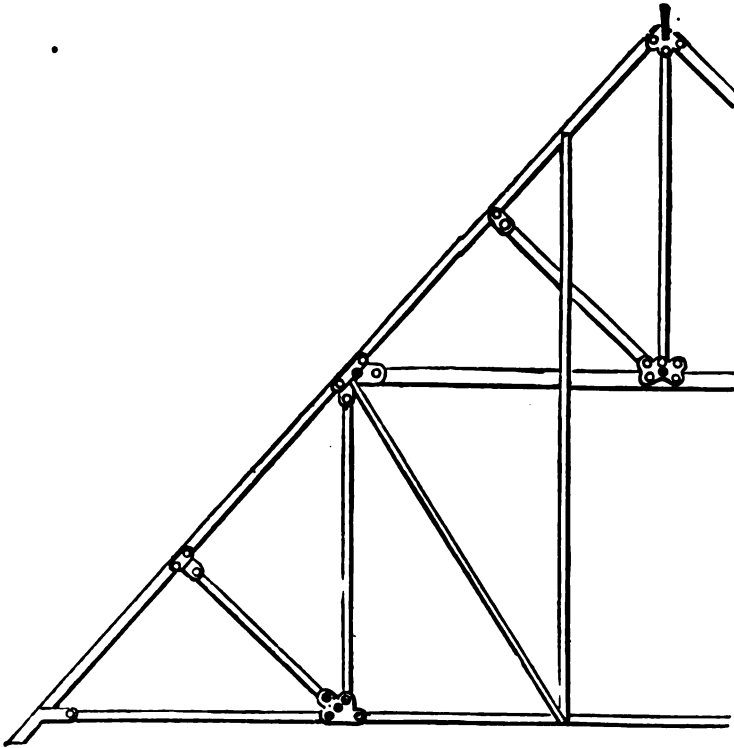

Fig. 211—Represents the half of a truss of wrought iron for the new Houses of Parliament, England. The pieces of this truss are formed of bars of a rectangular section. The joints are secured by cast-iron sockets, within which the ends of the bars are secured by screw bolts.

696. Fig. 213 shows a very common form of the roofs of gas-houses.

This here shown is supposed to be made entirely of iron. At the ridge is a ventilator to allow the escape of gases. The manner of joining the parts is sufficiently shown in the figure.

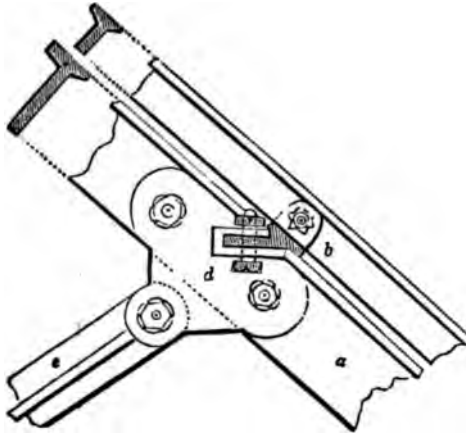

Fig. 212—Represents the arrangements of the parts at the joint c in Fig. 210.  
 A, side view of the pieces and joint.  
 a, principal rafter of the cross section B.  
 b, common rafter of the cross section C.  
 c, cross section of purlins and joint for fastening the common rafters to the purlins.  
 d, cast-iron socket arranged to confine the pieces a, b, c, e.

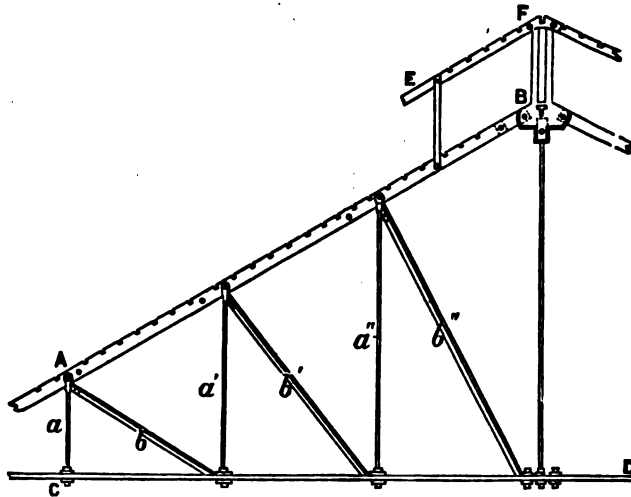

Fig. 213.—Ordinary roof of a gas-house. A, B, is the main rafter.  
 a, a'' are vertical tie-rods.  
 b, b'' are braces.  
 C, D, is the main tie.  
 E, F, is the ventiator.

697. Fig. 214 shows a mode of secondary trussing. A is a strut for supporting the middle of the main rafter. The lower end of A is secured to a block which is supported by the tie-rods B and D. The tie-rods C and D serve the office of a single tie for supporting the lower end of E. In this

way the rod D performs a double office. It may be questionable whether this arrangement is as good as it would be to have one continuous rod pass from E to F, and another rod (D) to act with B.

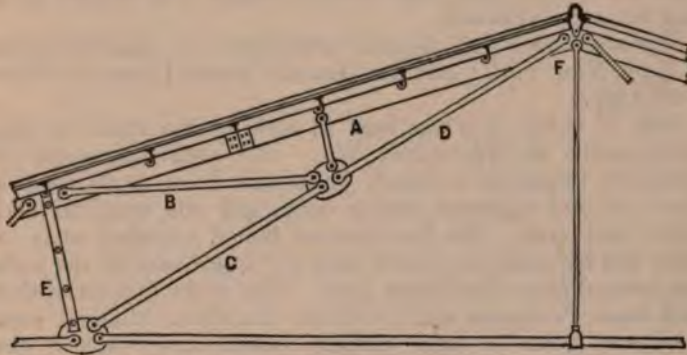

Fig. 214—A is a strut, the lower end of which is supported by the ties B and D. C and D serve the office of a continuous tie for supporting the lower end of the strut E.

It may be observed that in this Fig. the tie-rods are inclined and much longer than the struts, which is the reverse of the condition in Fig. 213. If iron only is used the arrangement of Fig. 214 will generally be the most economical, but if wooden struts are used the plan of Fig. 213 may be preferable.



Fig. 215.

698. Depot Roof Truss. Fig. 215 shows a truss which has been used in many cases for supporting the roofs of depots and of other large buildings. The passenger depot of the

Michigan Central Railroad at Chicago was built after this plan. It was destroyed by the great fire in 1871. The plan of the arch is a Howe truss, having curved wooden chords, wooden braces and iron ties to connect the two chords. The truss formed an arch, the thrust of which was resisted by a long horizontal tie-rod.

The same style was adopted in the new roof over the depot at Troy, New York; and the Grand Central Depot in New York City.

699. A novel plan was used in making the roof over the rolling-mills at Milwaukee, Wis. An arch was made of boards so placed as to break joints and form a rib about a foot wide and eighteen inches deep, and one hundred and eighty feet span. The boards were bolted together so as to make the rib continuous, and then the upper part of the arch was trussed after the Howe plan. The main objects of this plan were cheapness and to secure the whole enclosed area free from posts or other similar obstructions. But it was found that the arch was too weak, especially when required to carry the large ventilator which was placed over it, and posts were afterwards added.

700. **Roofs and Domes.** In some cases—especially in state buildings—domes are placed upon roofs for architectural effect.

Fig. 216.

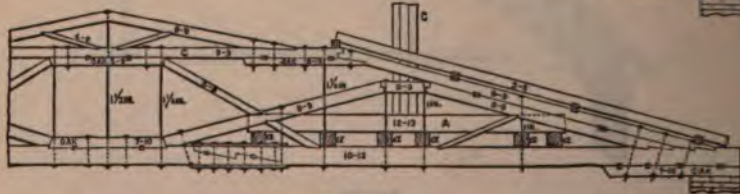
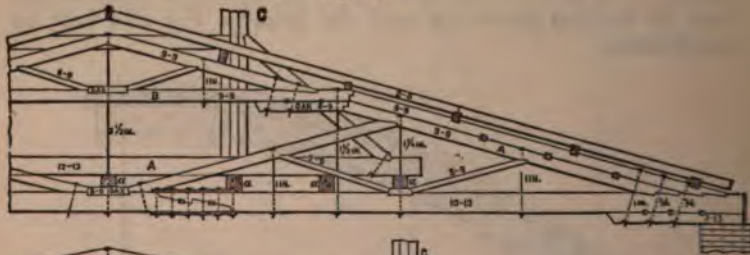

Fig. 217.

Figs. 216 and 217—Are two trusses, which are made in pairs, and are placed fourteen inches apart, for supporting part of the dome (octagonal) of the State capital at Montpelier, Vt.

*a a a* are the short timbers for connecting the two trusses.

*A* is a timber resting upon the cross pieces *a a a*.

*C* is a post of the dome resting upon the piece *A*.

Span, sixty-seven feet four inches.

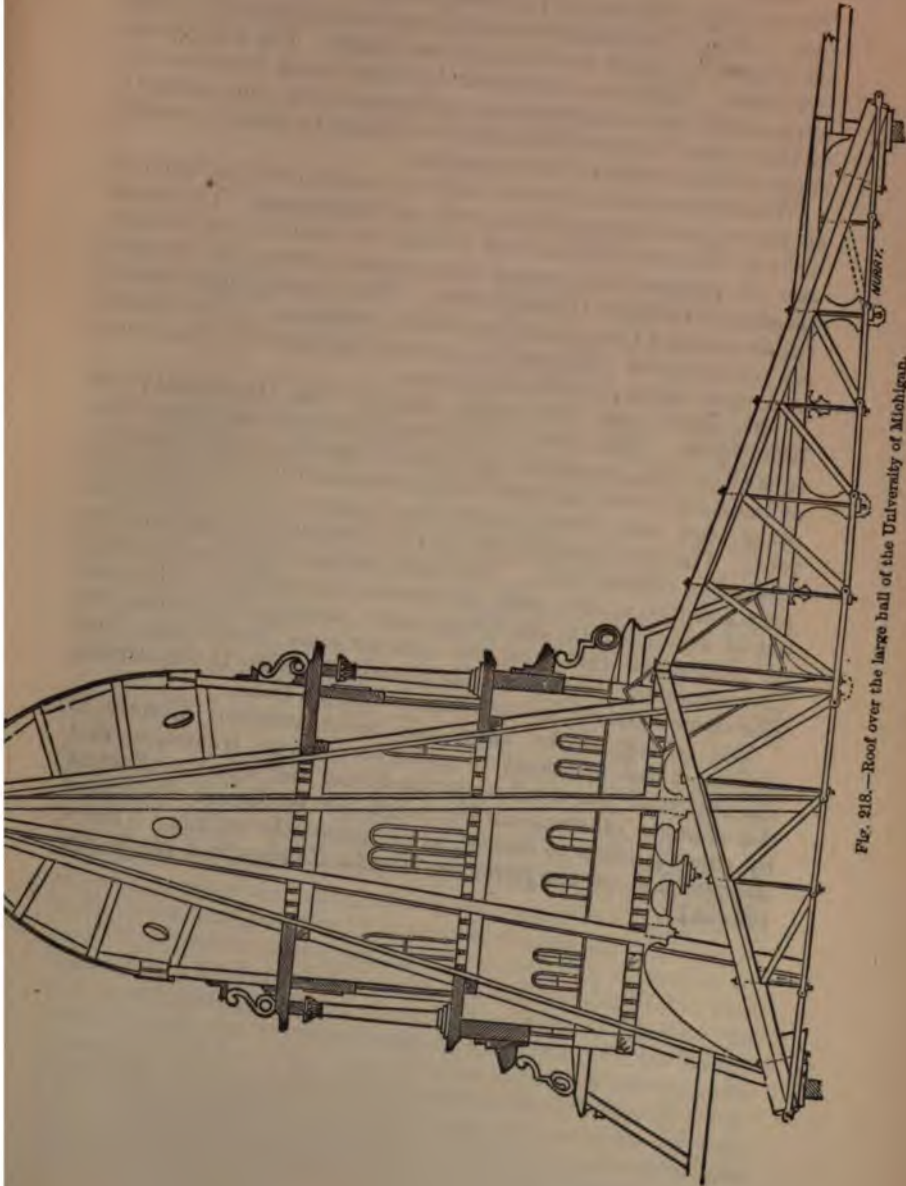

Fig. 218.—Roof over the large hall of the University of Michigan.



The dome of the State capitol, Vermont, rests upon wooden trusses (Figs. 216 and 217), having a span of sixty-seven feet four inches. The trusses are supported at the ends only. They are placed in pairs, fourteen inches apart. The Fig. shows two pairs. They are connected by short cross beams, *a a*; upon which rest other timbers, *A*, for receiving the posts, *C*, of the dome. It is profitable for the student to make a careful study of the details of this structure.

Where the thrust is severe especial care should be taken to secure a good bearing for the ends of the timbers. The lower ends of the main rafters tend to shear the main tie at its ends, and to prevent this action they should enter the tie at a reasonable distance from its ends. The bearing pieces are of white oak, and the rest of the timber is spruce. The trusses are constructed differently, because the posts of the dome bear upon them in different places.

**701. Roof over the large hall of the University of Michigan.** This truss and dome presents a very novel feature (Fig. 218), inasmuch as a part of the dome rests directly, or nearly so, upon the posts which support the roof, while the other part rests directly upon the trusses which support the roof. The span is eighty feet in the clear, and the depth of the trusses is sixteen feet. The main rafters are pieces of solid pine fourteen inches wide by sixteen inches deep. They are not of equal length, the longer ones having a horizontal run of forty-seven feet, and the shorter ones thirty-three feet. The secondary trussing is distributed according to the strains. The dome is thirty feet in diameter at the base.

The ceiling of the large hall being attached directly to trusses, it was necessary to make very strong trusses, so that the action of the wind upon the dome, and also the effect of the changes of temperature might not so disturb the trusses by causing them to deflect, as to destroy the ceiling. (For a computation of the parts, see *Wood's Bridges and Roofs*, pp. 194-211.

## CHAPTER VII.

## ROADS.

## I. COMMON ROADS. II. RAILROADS.

702. In establishing a line of internal communication of any character, whether it be an ordinary road, railroad, or canal, the main considerations to which the attention of the engineer must be directed in the outset are: 1, the probable character and amount of traffic over the line; 2, the wants of the community in the neighborhood of the line; 3, the natural features of the country, between the points of *arrival* and *departure*, as regards their adaptation to the proposed communication.

As the last point alone comes exclusively within the province of the engineer's art, and within the limits prescribed to this work, attention will be confined solely to its consideration.

703. **Reconnaissance.** A thorough examination and study of the ground by the eye, termed a *reconnaissance*, is an indispensable preliminary to any more accurate and minute survey by instruments, to avoid loss of time, as by this more rapid operation any ground unsuitable for the proposed line will be as certainly detected by a person of some experience, as it could be by the slow process of an instrumental survey. Before, however, proceeding to make a reconnaissance, a careful inspection of the general maps of that portion of the country through which the communication is to pass will facilitate, and may considerably abridge the labors of the engineer; as from the natural features laid down upon them, particularly the direction of the water-courses, he will at once be able to detect those points which will be favorable, or otherwise, to the general direction selected for the line. This will be sufficiently evident when it is considered—1, that the water-courses are necessarily the lowest lines of the valleys through which they flow, and that their direction must also be that of the lines of greatest declivity of their respective valleys; 2, that from the position of the water-courses the position also of the high grounds by which they are separated naturally follows, as well as the approximate position at least

of the ridges, or highest lines of the high grounds, which separate their opposite slopes, and which are at the same time the lines of greatest declivity common to these slopes, as the water-courses are the corresponding lines of the slopes that form the valleys.

Keeping these facts (which are susceptible of rigid mathematical demonstration) in view, it will be practicable, from a careful examination of an ordinary general map, if accurately constructed, not only to trace, with considerable accuracy, the general direction of the ridges from having that of the water-courses, but also to detect those depressions in them which will be favorable to the passage of a communication intended to connect two main or two secondary valleys. The following illustrations may serve to place this subject in a clearer aspect.

If, for example, it be found that on any portion of a map the water-courses seem to diverge from or converge towards one point, it will be evident that the ground in the first case must be the common source or supply of the water-courses, and therefore the highest; and in the second case that it is the lowest, and forms their common recipient.

If two water-courses flow in opposite directions from a common point, it will show that this is the point from which they derive their common supply, at the head of their respective valleys, and that it must be fed by the slopes of high grounds above this point; or, in other words, that the valleys of the two water-courses are separated by a chain of high grounds, which, at the point where it crosses them, presents a depression in its ridge, which would be the natural position for a communication connecting the two valleys.

If two water-courses flow in the same direction and parallel to each other, it will simply indicate a general inclination of the ridge between them, in the same direction as that of the water-courses. The ridge, however, may present in its course elevations and depressions, which will be indicated by the points in which the water-courses of the secondary valleys, on each side of it, intersect each other on it; and these will be the lowest points at which lines of communication, through the secondary valleys, connecting the main water-courses, would cross the dividing ridge.

If two water-courses flow in the same direction, and parallel to each other, and then at a certain point assume divergent directions, it will indicate that this is the lowest point of the ridge between them.

If two water-courses flow in parallel but opposite directions,

depressions in the ridge between them will be shown by the meeting of the water-courses of the secondary valleys on the ridge; or by an approach towards each other, at any point, of the two principal water-courses.

Furnished with the data obtained from the maps, the character of the ground should be carefully studied both ways by the engineer, first from the point of departure to that of arrival, and then returning from the latter to the former, as without this double traverse natural features of essential importance might escape the eye.

**704. Surveys.** From the results of the reconnaissance, the engineer will be able to direct understandingly the requisite surveys, which consist in measuring the lengths, determining the directions, and ascertaining both the longitudinal and cross levels of the different routes, or, as they are termed, *trial-lines*, with sufficient accuracy to enable him to make a comparative estimate both of their practicability and cost. As the expense of making the requisite surveys is usually but a small item compared with that of constructing the communication, no labor should be spared in running every practicable line, as otherwise natural features might be overlooked which might have an important influence on the cost of construction.

**705. Map and Memoir.** The results of the surveys are accurately embodied in a map exhibiting minutely the topographical features and sections of the different trial-lines, and in a memoir which should contain a particular description of those features of the ground that cannot be shown on a map, with all such information on other points that may be regarded as favorable, or otherwise, to the proposed communication; as, for example, the nature of the soil, that of the water-courses met with, etc., etc.

**706. Location of Common Roads.** In selecting among the different trial-lines of the survey the one most suitable to a common road, the engineer is less restricted, from the nature of the conveyance used, than in any other kind of communication. The main points to which his attention should be confined are: 1, to connect the points of arrival and departure by the most direct, or shortest line; 2, to avoid unnecessary ascents and descents, or, in other words, to reduce the ascents and descents to the smallest practicable limit; 3, to adopt such suitable slopes, or *gradients*, for the *axis*, or centre line of the road, as the nature of the conveyance may demand; 4, to give the axis such a position with regard to the surface of the ground and the natural obstacles

to be overcome, that the cost of construction for the excavations and embankments required by the gradients, and for the bridges and other accessories, shall be reduced to the lowest amount.

707. Deviations from the right line drawn on the map, between the points of arrival and departure, will be often demanded by the natural features of the ground. In passing the dividing ridges of main, or secondary valleys, for example, it will frequently be found more advantageous, both for the most suitable gradients, and to diminish the amount of excavation and embankment, to cross the ridge at a lower point than the one in which it is intersected by the right line, deviating from the right line either towards the *head*, or upper part of the valley, or towards its outlet, according to the advantages presented by the natural features of the ground, both for reducing the gradients and the amount of excavation and embankment.

Where the right line intersects either a marsh or water-course, it may be found less expensive to change the direction, avoiding the marsh, or intersecting the water-course at a point where the cost of construction of a bridge, or of the approaches to it, will be more favorable than the one in which it is intersected by the right line.

Changes from the direction of the right line may also be favorable for the purpose of avoiding the intersection of secondary water-courses; of gaining a better soil for the roadway; of giving a better exposure of its surface to the sun and wind; or of procuring better materials for the road-covering.

By a careful comparison of the advantages presented by these different features, the engineer will be enabled to decide how far the general direction of the right line may be departed from with advantage to the location. By choosing a more sinuous course the length of the line will often not be increased to any very considerable degree, while the cost of construction may be greatly reduced, either in obtaining more favorable gradients, or in lessening the amount of excavation and embankment.

708. When the points of arrival and departure are upon different levels, as is usually the case, it will seldom be practicable to connect them by a continual ascent. The most that can be done will be to cross the dividing ridges at their lowest points, and to avoid, as far as practicable, the intersection of considerable secondary valleys which might require any considerable ascent on one side and descent on the other

709. The gradients upon common roads will depend upon the kind of material used for the road-covering, and upon the state in which the road-surface is kept. The gradient in all cases should be less than the *angle of repose*, or of that inclination of the axis of the road in which the ordinary vehicles for transportation would remain at a state of rest, or, if placed in motion, would descend by the action of gravity with uniform velocity.

The gradients corresponding to the angle of repose have been ascertained by experiments made upon the various road-coverings in ordinary use, by allowing a vehicle to descend along a road of variable inclination until it was brought to a state of rest by the retarding force of friction; also, by ascertaining the amount of force, termed *the force of traction*, requisite to put in motion a vehicle with a given load on a level road.

The following are the results of experiments made by Mr. Macneill, in England, to determine the force of traction for one ton upon level roads:—

No. 1. Good pavement, the force of traction is. . . . .	33 lbs.
“ 2. Broken-stone surface laid on an old flint road	65 “
“ 3. Gravel road. . . . .	147 “
“ 4. Broken-stone surface on a rough pavement bottom. . . . .	46 “
“ 5. Broken-stone surface on a bottom of beton. . . . .	46 “

From this it appears that the angle of repose in the first case is represented by  $\frac{33}{100}$ , or  $\frac{1}{3}$  nearly; and that the slope of the road should therefore not be greater than one perpendicular to sixty-eight in length; or that the height to be overcome must not be greater than one sixty-eighth of the distance between the two points measured along the road, in order that the force of friction may counteract that of gravity in the direction of the road.

A similar calculation will show that the angle of repose in the other cases will be as follows:

No. 2. . . . . 1 to . . . . .	35 nearly.
“ 3. . . . . 1 to . . . . .	15 “
“ 4 and 5. . . . . 1 to . . . . .	49 “

These numbers, which give the angle of repose between  $\frac{1}{3}$  and  $\frac{1}{4}$  for the kinds of road-covering Nos. 2 and 4 in most ordinary use, and corresponding to a road-surface in good order, may be somewhat increased, to from  $\frac{1}{3}$  to  $\frac{1}{3}$ , for the ordinary state of the surface of a well-kept road, without there being any necessity for applying a brake to the wheels in descending, or going out of a trot in ascending. The

steepest gradient that can be allowed on roads with a broken stone covering is about  $\frac{1}{10}$ , as this, from experience, is found to be about the angle of repose upon roads of this character in the state in which they are usually kept. Upon a road with this inclination, a horse can draw at a walk his usual load for a level without requiring the assistance of an extra horse; and experience has farther shown that a horse at the usual walking pace will attain, with less apparent fatigue, the summit of a gradient of  $\frac{1}{8}$  in nearly the same time that he would require to reach the same point on a trot over a gradient of  $\frac{1}{3}$ .

A road on a dead level, or one with a continued and uniform ascent between the points of arrival and departure, where they lie upon different levels, is not the most favorable to the draft of the horse. Each of these seems to fatigue him more than a line of alternate ascents and descents of slight gradients; as, for example, gradients of  $\frac{1}{10}$ , upon which a horse will draw as heavy a load with the same speed as upon a horizontal road.

The gradients should in all cases be reduced as far as practicable, as the extra exertion that a horse must put forth in overcoming heavy gradients is very considerable; they should as a general rule, therefore, be kept as low at least as  $\frac{1}{8}$ , wherever the ground will admit of it. This can generally be effected, even in ascending steep hill-sides, by giving the axis of the road a zigzag direction, connecting the straight portions of the zigzags by circular arcs. The gradients of the curved portions of the zigzags should be reduced, and the roadway also at these points be widened, for the safety of vehicles descending rapidly. The width of the roadway may be increased about one-fourth, when the angle between the straight portions of the zigzags is from  $120^\circ$  to  $90^\circ$ ; and the increase should be nearly one-half where the angle is from  $90^\circ$  to  $60^\circ$ .

710. Having laid down upon the map the approximate location of the axis of the road, a comparison can then be made between the solid contents of the excavations and embankments, which should be so adjusted that they shall balance each other, or, in other words, the necessary excavations shall furnish sufficient earth to form the embankments. To effect this, it will frequently be necessary to alter the first location, by shifting the position of the axis to the right or left of the position first assumed, and also by changing the gradients within the prescribed limits. This is a problem of very considerable intricacy, whose solution can be arrived at only by

successive approximations. For this purpose, the line must be subdivided into several portions, in each of which the equalization should be attempted independently of the rest, instead of trying a general equalization for the whole line at once.

In the calculations of solid contents required in balancing the excavations and embankments, the most accurate method consists in subdividing the different solids into others of the most simple geometrical forms, as prisms, prismoids, wedges, and pyramids, whose solidities are readily determined by the ordinary rules for the mensuration of solids. As this process, however, is frequently long and tedious, other methods requiring less time, but not so accurate, are generally preferred, as their results give an approximation sufficiently near the true for most practical purposes. They consist in taking a number of equidistant profiles, and calculating the solid contents between each pair, either by multiplying the half sum of their areas by the distance between them, or else by taking the profile at the middle point between each pair, and multiplying its area by the same length as before. The latter method is the more expeditious; it gives less than the true solid contents, but a nearer approximation than the former, which gives more than the true solid contents, whatever may be the form of the ground between each pair of cross profiles.

In calculating the solid contents, allowance must be made for the difference in bulk between the different kinds of earth when occupying their natural bed and when made into embankment. From some careful experiments on this point made by Mr. Elwood Morris, a civil engineer, and published in the *Journal of the Franklin Institute*, it appears that light sandy earth occupies the same space both in excavation and embankment; clayey earth about one-tenth less in embankment than in its natural bed; gravelly earth also about one-twelfth less; rock in large fragments about five-twelfths more, and in small fragments about six-tenths more.

711. Another problem connected with the one in question is that of determining the *lead*, or the *mean distance to which the earth taken from the excavations must be carried to form the embankments*. From the manner in which the earth is usually transported from the one to the other, this distance is usually that between the centre of gravity of the solid of excavation and that of its corresponding embankment. Whatever disposition may be made of the solids of excavation, it is important, so far as the cost of their removal is concerned.



that the lead should be the least possible. The solution of the problem under this point of view will frequently be extremely intricate, and demand the application of all the resources of the higher analysis. One general principle, however, is to be observed in all cases, in order to obtain an approximate solution, which is, that in the removal of the different portions of the solid of excavation to their corresponding positions on that of the embankment, the paths passed over by their respective centres of gravity shall not cross each other either in a horizontal or vertical direction. This may in most cases be effected by intersecting the solids of excavation and embankment by vertical planes in the direction of the removal, and by removing the partial solids between the planes within the boundaries marked out by them.

712. The definitive location having been settled by again going over the line, and comparing the features of the ground with the results furnished by the preceding operations, general and detailed maps of the different divisions of the definitive location are prepared, which should give, with the utmost accuracy, the longitudinal and cross sections of the natural ground, and of the excavations and embankments, with the horizontal and vertical measurements carefully written upon them, so that the superintending engineer may have no difficulty in setting out the work from them on the ground.

In addition to these maps, which are mainly intended to guide the engineer in regulating the earth-work, detailed drawings of the road-covering, of the masonry and carpentry of the bridges, culverts, etc., accompanied by written specifications of the manner in which the various kind of work is to be performed, should be prepared for the guidance both of the engineer and workmen.

713. With the data furnished by the maps and drawings, the engineer can proceed to *set out the line on the ground*. The axis of the road is determined by placing stout stakes or pickets at equal intervals apart, which are numbered to correspond with the same points on the map. The width of the roadway and the lines on the ground corresponding to the side slopes of the excavations and embankments are laid out in the same manner, by stakes placed along the lines of the cross profiles.

Besides the numbers marked on the stakes, to indicate their position on the map, other numbers, showing the depth of the excavations, or the height of the embankments from the sur-

face of the ground, accompanied by the letters *Out. Fill.* to indicate a *cutting*, or a *filling*, as the case may be, are also added to guide the workmen in their operations. The positions of the stakes on the ground, which show the principal points of the axis of the road, should, moreover, be laid down on the map with great accuracy, by ascertaining their bearing and distances from any fixed and marked objects in their vicinity, in order that the points may be readily found should the stakes be subsequently misplaced.

**714. Earth-Work.** This term is applied to whatever relates to the construction of the excavations and embankments, to prepare them for receiving the road-covering.

**715.** In forming the excavations, the *inclination of the side slopes demands* peculiar attention. This inclination will depend on the nature of the soil, and the action of the atmosphere and internal moisture upon it. In common soils, as ordinary garden earth formed of a mixture of clay and sand, compact clay, and compact stony soils, although the side slopes would withstand very well the effects of the weather with a greater inclination, it is best to give them two base to one perpendicular, as the surface of the roadway will, by this arrangement, be well exposed to the action of the sun and air, which will cause a rapid evaporation of the moisture on the surface. Pure sand and gravel may require a greater slope, according to circumstances. In all cases where the depth of the excavation is great, the base of the slope should be increased. It is not usual to use any artificial means to protect the surface of the side slopes from the action of the weather; but it is a precaution which, in the end, will save much labor and expense in keeping the roadway in good order. The simplest means which can be used for this purpose consist in covering the slopes with good sods. (Fig. 219), or



Fig. 219. Cross-section of a road in excavation.

A, road-surface.  
B, side slopes.  
C, top surface-drain.

else with a layer of vegetable mould about four inches thick, carefully laid and sown with grass-seed. These means will be amply sufficient to protect the side slopes from injury when they are not exposed to any other causes of deterioration than the wash of the rain, and the action of frost on the ordinary moisture retained by the soil.

The side slopes form usually an unbroken surface from the

foot to the top. But in deep excavations, and particularly in soils liable to slips, they are sometimes formed with horizontal offsets, termed *benches*, which are made a few feet wide, and have a ditch on the inner side to receive the surface water from the portion of the side slope above them. These benches catch and retain the earth that may fall from the portion of the side slope above.

When the side slopes are not protected, it will be well, in localities where stone is plenty, to raise a small wall of dry stone at the foot of the slopes, to prevent the wash of the slopes from being carried into the roadway.

A covering of brushwood, or a thatch of straw, may also be used with good effect; but, from their perishable nature, they will require frequent renewal and repairs.

In excavations through solid rock, which does not disintegrate on exposure to the atmosphere, the side slopes might be made perpendicular; but as this would exclude, in a great degree, the action of the sun and air, which is essential to keeping the road-surface dry and in good order, it will be necessary to make the side slopes with an inclination, varying from one base to one perpendicular, to one base to two perpendicular, or even greater, according to the locality; the inclination of the slope on the south side in northern latitudes being greatest, to expose better the road-surface to the sun's rays.

The slaty rocks generally decompose rapidly on the surface, when exposed to moisture and the action of frost. The side slopes in rocks of this character may be cut into steps



Fig. 220.

(Fig. 220), and then be covered by a layer of vegetable mould sown in grass-seed, or else the earth may be sodded in the usual way.

716. The stratified soils and rocks, in which the strata have a *dip*, or inclination to the horizon, are liable to *slips*, or to give way by one stratum becoming detached and sliding on another, which is caused either from the action of frost, or from the pressure of water, which insinuates itself between

the strata. The worst soils of this character are those formed of alternate strata of clay and sand; particularly if the clay is of a nature to become semi-fluid when mixed with water. The best preventives that can be resorted to in these cases are to adopt a thorough system of drainage, to prevent the surface-water of the ground from running down the side slopes, and to cut off all springs which run towards the roadway from the side slopes. The surface-water may be cut off by means of a single ditch (Fig. 219) made on the up-hill side of the road, to catch the water before it reaches the slope of the excavation, and convey it off to the natural water-courses most convenient; as, in almost every case, it will be found that the side slope on the down-hill side is, comparatively speaking, but slightly affected by the surface-water.

Where *slips* occur from the action of springs, it frequently becomes a very difficult task to secure the side slopes. If the sources can be easily reached by excavating into the side slopes, drains formed of layers of fascines or brush-wood may be placed to give an outlet to the water, and prevent its action upon the side slopes. The fascines may be covered on top with good sods laid with the grass side beneath, and the excavation made to place the drain be filled in with good earth well rammed. Drains formed of broken stone, covered in like manner on top with a layer of sod to prevent the drain from becoming choked with earth, may be used under the same circumstances as fascine drains. Where the sources are not isolated, and the whole mass of the soil forming the side slopes appears saturated, the drainage may be effected by excavating trenches a few feet wide at intervals to the depth of some feet into the side slopes, and filling them with broken stone, or else a general drain of broken stone may be made throughout the whole extent of the side slope by excavating into it. When this is deemed necessary, it will be well to arrange the drain like an inclined retaining-wall, with buttresses at intervals projecting into the earth farther than the general mass of the drain. The front face of the drain should, in this case, also be covered with a layer of sods with the grass side beneath, and upon this a layer of good earth should be compactly laid to form the face of the side slopes. The drain need only be carried high enough above the foot of the side slope to tap all the sources; and it should be sunk sufficiently below the roadway-surface to give it a secure footing.

The drainage has been effected, in some cases, by sinking wells or *shafts* at some distance behind the side slopes, from

the top surface to the level of the bottom of the excavation and leading the water which collects in them by pipes into drains at the foot of the side slopes. In others a narrow trench has been excavated, parallel to the axis of the road, from the top surface to a sufficient depth to tap all the sources which flow towards the side slope, and a drain formed either by filling the trench wholly with broken stone, or else by arranging an open conduit at the bottom to receive the water collected, over which a layer of brushwood is laid, the remainder of the trench being filled with broken stone.

717. In forming the embankments (Fig. 221), the side



Fig. 221.

slopes should be made with a less inclination than that which the earth naturally assumes; for the purpose of giving them greater durability, and to prevent the width of the top surface, along which the roadway is made, from diminishing by every change in the side slopes, as it would were they made with the natural slope. To protect the side slopes more effectually, they should be sodded, or sown in grass-seed; and the surface-water of the top should not be allowed to run down them, as it would soon wash them into gullies, and destroy the embankment. In localities where stone is plenty, a sustaining wall of dry stone may be advantageously substituted for the side slopes.

To prevent, as far as possible, the settling which takes place in embankments, they should be formed with great care; the earth being laid in successive layers of about four feet in thickness, and each layer well settled with rammers. As this method is very expensive, it is seldom resorted to except in works which require great care, and are of trifling extent. For extensive works, the method usually followed, on account of economy, is to embank out from one end, carrying forward the work on a level with the top surface. In this case, as there must be a want of compactness in the mass, it would be best to form the outsides of the embankment first, and to gradually fill in towards the centre, in order that the earth may arrange itself in layers with a dip from the sides inwards: this will in a great measure counteract any tendency to slips outward. The foot of the slopes should be se-

cured by buttressing them either by a low stone wall, or by forming a slight excavation for the same purpose.

718. When the axis of the roadway is laid out on the side slope of a hill, and the road-surface is formed partly by excavating and partly by embanking out, the usual and most simple method is to extend out the embankment gradually along the whole line of excavation. This method is insecure, and no pains therefore should be spared to give the embankment a good footing on the natural surface upon which it rests, particularly at the foot of the slope. For this purpose the natural surface (Fig. 222) should be cut into steps, or off-



Fig. 222.

sets, and the foot of the slope be secured by buttressing it against a low stone wall, or a small terrace of carefully rammed earth.

In side-formings along a natural surface of great inclination, the method of construction just explained will not be sufficiently secure; sustaining-walls must be substituted for the side slopes, both of the excavations and embankments. These walls may be made simply of dry stone, when the stone can be procured in blocks of sufficient size to render this kind of construction of sufficient stability to resist the pressure of the earth. But when the blocks of stone do not offer this security, they must be laid in mortar (Fig. 223), and hydraulic mortar is the only kind which will form a safe construction. The wall which supplies the slope of the excavation should be carried up as high as the natural surface of the ground; the one that sustains the embankment should be built up to the surface of the roadway; and a parapet-wall should be raised upon it, to secure vehicles from accidents in deviating from the line of the roadway.

A road may be constructed partly in excavation and partly in embankment along a rocky ledge, by blasting the rock,

when the inclination of the natural surface is not greater than one perpendicular to two base; but with a greater inclination than this, the whole should be in excavation.



Fig. 223.—Cross section of a road in steep side-forming.

A, filling.  
B, sustaining-wall of filling.  
C, breast-wall of cutting.  
D, parapet-wall of footpath.

719. There are examples of road constructions, in localities like the last, supported on a framework, consisting of horizontal pieces, which are firmly fixed at one end by being let into holes drilled in the rock, and are sustained at the other by an inclined strut underneath, which rests against the rock in a shoulder formed to receive it.

720. When the excavations do not furnish sufficient earth for the embankments, it is obtained from excavations termed *side-cuttings*, made at some place in the vicinity of the embankment, from which the earth can be obtained with most economy.

If the excavations furnish more earth than is required for the embankment, it is deposited in what is termed *spoil-bank*, on the side of the excavation. The spoil-bank should be made at some distance back from the side slope of the excavation, and on the down-hill side of the top surface; and suitable drains should be arranged to carry off any water that might collect near it and affect the side slope of the excavation.

The forms to be given to side-cuttings and spoil-banks will depend, in a great degree, upon the locality: they should, as far as practicable, be such that the cost of removal of the earth shall be the least possible.

721. *Drainage.* A system of thorough drainage, by which the water that filters through the ground will be cut off from the soil beneath the roadway, to a depth of at least three feet below the bottom of the road-covering, and by which that which falls upon the surface will be speedily conveyed off,

fore it can filter through the road-covering, is essential to the good condition of a road.

The surface-water is conveyed off by giving the surface of the roadway a slight transverse convexity, from the middle to the sides, where the water is received into the gutters, or *side-channels*, from which it is conveyed by underground aqueducts, termed *culverts*, built of stone or brick and usually arched at top, into the main drains that communicate with the natural water-courses. This convexity is regulated by making the figure of the profile an ellipse, of which the semi-transverse axis is 15 feet, and the semi-conjugate axis 9 inches; thus placing the middle of the roadway nine inches above the bottom of the side channels. This convexity, which is as great as should be given, will not be sufficient in a flat country to keep the road-surface dry; and in such localities, if a slight longitudinal slope cannot be given to the road, it should be raised, when practicable, three or four feet above the general level; both on account of conveying off speedily the surface-water, and exposing the surface better to the action of the wind.

To drain the soil beneath the roadway in a level country, ditches, termed *open side drains* (Fig. 224), are made paral-



Fig. 224.—Cross-section of broken-stone road-covering.

- A, road-surface,
- B, side channels,
- C, footpath,
- D, covered drains, or culverts, leading from side channels to the side drains E.

lel to the road, and at some feet from it on each side. The bottom of the side drains should be at least three feet below the road-covering; their size will depend on the nature of the soil to be drained. In a cultivated country the side drains should be on the field side of the fences.

As open drains would be soon filled along the parts of a road in excavation, by the washings from the side-slopes covered drains, built either of brick or stone, must be substituted for them. These drains (Fig. 225) consist simply of a flooring of flagging stone, or of brick, with two side walls of



rubble, or brick masonry, which support a top covering of flat stones, or of brick, with open joints, of about half an inch, to give a free passage-way to the water into the drain. The top is covered with a layer of straw or brushwood; and clean gravel, or broken stone, in small fragments, is laid over this, for the purpose of allowing the water to filter freely through to the drain, without carrying with it any earth or sediment, which might in time accumulate and choke it. The width and height of covered drains will depend on the materials of which they are built, and the quantity of water to which they yield a passage.



Fig. 225.—Cross-section of a covered drain.  
 A, drain.  
 a, a, side walls.  
 b, top stones.  
 c, bottom stones.  
 d, broken stone or large gravel laid over brush.

Besides the longitudinal covered drains in cuttings, other drains are made under the roadway which, from their form, are termed *cross mitre drains*. Their plan is in shape like the letter V, the angular point being at the centre of the road, and pointing in the direction of its ascent. The angle should be so regulated that the bottom of the drain shall not have a greater slope along either of its branches, than one perpendicular to one hundred base, to preserve the masonry from damage by the current. The construction of mitre drains is the same as the covered longitudinal drains. They should be placed at intervals of about 60 yards from each other.

In some cases surface drains, termed *catch-water drains*, are made on the side slopes of cuttings. They are run up obliquely along the surface, and empty directly into the cross drains which convey the water into the natural water-courses.

When the roadway is in side-forming, cross drains of the ordinary form of culverts are made to convey the water from the side channels and the covered drains into the natural water-courses. They should be of sufficient dimensions to convey off a large volume of water, and to admit a man to pass through them so that they may be readily cleared out, or even repaired, without breaking up the roadway over them.

The only drains required for embankments are the ordi-

nary side channels of the roadway, with occasional culverts to convey the water from them into the natural water-courses. Great care should be taken to prevent the surface-water from running down the side slopes, as they would soon be washed into gullies by it.

Very wet and marshy soils require to be thoroughly drained before the roadway can be made with safety. The best system that can be followed in such cases is to cut a wide and deep open main-drain on each side of the road, to convey the water to the natural water-courses. Covered cross drains should be made at frequent intervals, to drain the soil under the roadway. They should be sunk as low as will admit of the water running from them into the main drains, by giving a slight slope to the bottom each way from the centre of the road to facilitate its flow.

Independently of the drainage for marshy soils, they will require, when the subsoil is of a spongy, elastic nature, an artificial bed for the road covering. This bed may, in some cases, be formed by simply removing the upper stratum to a depth of several feet, and supplying its place with well-packed gravel, or any soil of a firm character. In other cases, when the subsoil yields readily to the ordinary pressure that the road-surface must bear, a bed of brushwood, from 9 to 18 inches in thickness, must be formed to receive the soil on which the road-covering is to rest. The brushwood should be carefully selected from the long straight slender shoots of the branches or undergrowth, and be tied up in bundles, termed *fascines*, from 9 to 12 inches in diameter, and from 10 to 20 feet long. The fascines are laid in alternate layers crosswise and lengthwise, and the layers are either connected by pickets, or else the withes, with which the fascines are bound, are cut to allow the brushwood to form a uniform and compact bed.

This method of securing a good bed for structures on a weak wet soil has been long practised in Holland, and experience has fully tested its excellence.

**722. Road-coverings.** The object of a road-covering being to diminish the resistances arising from collision and friction, and thereby to reduce the force of traction to the least practicable amount, it should be composed of hard and durable materials, laid on a firm foundation, and present a uniform, even surface.

The material in ordinary use for road-coverings is stone, in the shape of blocks of a regular form, or of large round pebbles, termed a *pavement*, or broken into small angular masses; or in the form of gravel.

**723. Pavements.** The pavements in most general use in our country are constructed of rounded pebbles, known as *paving stones*, varying from 3 to 8 inches in diameter, which are set in a *form*, or bed of clean sand or gravel, a foot or two in thickness, which is laid upon the natural soil excavated to receive the form. The largest stones are placed in the centre of the roadway. The stones are carefully set in the form, in close contact with each other, and are then firmly settled by a heavy rammer until their tops are even with the general surface of the roadway, which should be of a slightly convex shape, having a slope of about  $\frac{1}{8}$  from the centre each way to the sides. After the stones are driven, the road-surface is covered with a layer of clean sand, or fine gravel, two or three inches in thickness, which is gradually worked in between the stones by the combined action of the travel over the pavement and of the weather.

The defects of pebble pavements are obvious, and confirmed by experience. The form of sand or gravel, as usually made, is not sufficiently firm; it should be made in separate layers of about 4 inches, each layer being moistened and well settled either by ramming, or passing a heavy roller over it. Upon the form prepared in this way a layer of loose material of two or three inches in thickness may be placed to receive the ends of the paving stones. From the form of the pebbles, the resistance to traction arising from collision and friction is very great.

Pavements termed *stone tramways* have been tried in some of the cities of Europe, both for light and heavy traffic. They are formed by laying two lines of long stone blocks for the wheels to run on, with a pavement of pebble for the horse-track between the wheel-tracks. In crowded thoroughfares tramways offer but few if any advantages, as it is impracticable to confine the vehicles to them, and when exposed to heavy traffic they wear into ruts. The stone blocks should be carefully laid on a very firm bottoming, and particular attention is requisite to prevent ruts from forming between the blocks and the pebble pavement.

Stone suitable for pavements should be hard and tough, and not wear smooth under the action to which it is exposed. Some varieties of granite have been found in England to furnish the best paving blocks. In France, a very fine-grained compact gray sandstone of a bluish cast is mostly in use for the same purpose, but it wears quite smooth.

The sand used for forms should be clean and free from pebbles and gravel of a larger grain than about two-tenths of an

inch. The form should be made by moistening the sand, and compressing it in layers of about four inches in thickness, either by ramming, or by passing over each layer several times a heavy iron roller. Upon the top layer about an inch of loose sand may be spread to receive the blocks; the joints between which, after they are placed, should be carefully filled with sand.

The sand form, when carefully made, presents a very firm and stable foundation for the pavement.

Wooden pavements, formed of blocks of wood of various shapes, have been tried in England and several of our cities within the last few years, and notwithstanding they decay in a few years, yet they are extensively used in many of our large cities. The travel upon them is so free from noise, and the surface is so smooth, that, on those streets where the haulage of heavy articles is not excessive, many property holders prefer to renew a wooden pavement every eight or ten years, than be annoyed with the noise and the roughness of stone pavements. They are especially desirable upon those streets which are occupied by residences.

Asphaltic pavements have undergone a like trial, and have been found to fail after a few years' service. This material is farther objectionable as a pavement in cities where the pavements and sidewalks have frequently to be disturbed for the purposes of repairing, or laying down sewers, water-pipes, and other necessary conveniences for a city.

The best system of pavement is that which has been partially put in practice in some of the commercial cities of England, the idea of which seems to have been taken from the excellent military roads of the Romans, vestiges of which remain at the present day in a good state.



Fig. 226.—Paved road-covering.

A, pavement.

C, curb-stone.

B, flagging of side-walk.

In constructing this pavement, a bed (Fig. 226) is first prepared, by removing the surface of the soil to the depth of a foot or more, to obtain a firm stratum; the surface of this bed receives a very slight convexity, of about two inches to ten feet, from the centre to the sides of the roadway. If the soil is of a soft clayey nature, into which small fragments of

broken stone would be easily worked by the wheels of vehicles, it should be excavated a foot or two deeper to receive a form of sand, or of clean fine gravel. On the surface of the bed thus prepared, a layer of small broken stone, four inches thick, is laid; the dimensions of these fragments should not be greater than two and a half inches in any direction; the road is then opened to vehicles until this first layer becomes perfectly compact; care being taken to fill up any ruts with fresh stone, in order to obtain a uniform surface. A second layer of stone, of the same thickness as the first, is then laid on, and treated in the same manner; and finally a third layer. When the third layer has become perfectly compact, and is of a uniform surface, a layer of fine clean gravel, two and a half inches thick, is spread evenly over it to receive the paving stones. The blocks of stone are of a square shape, and of different sizes, according to the nature of the travelling over the pavement. The largest size are ten inches thick, nine inches broad, and twelve inches long; the smallest are six inches thick, five inches broad, and ten inches long. Each block is carefully settled in the form, by means of a heavy beetle; it is then removed in order to cover the side of the one against which it is to rest with hydraulic mortar; this being done, the block is replaced, and properly adjusted. The blocks of the different courses across the roadway should break joints. The surface of the road is convex; the convexity being determined by making the outer edges six inches lower than the middle, for a width of thirty feet.

This system of pavement fulfils in the best manner all the requisites of a good road-covering, presenting a hard even surface to the action of the wheels, and reposing on a firm bed formed by the broken-stone bottoming. The mortar-joints, so long as they remain tight, will effectually prevent the penetration of water beneath the pavement; but it is probable, from the effect of the transit of heavily-laden vehicles, and from the expansion and contraction of the stone, which in our climate is found to be very considerable, that the mortar would soon be crushed and washed out.

In France, and in many of the large cities of the continent, the pavements are made with blocks of rough stone of a cubical form measuring between eight and nine inches along the edge of the cube. These are laid on a form of sand of only a few inches thick when the soil beneath is firm; but in bad soils the thickness is increased to from six to twelve inches. The transversal joints are usually continuous, and those in the direction of the axis of the road break joints. In some cases

the blocks are so laid that the joints make an angle of  $45^{\circ}$  with the axis of the roadway, one set being continuous, the other breaking joints with them. By this arrangement of the joints, it is said that the wear upon the edges of the blocks, by which the upper surface soon assumes a convex shape, is diminished. It has been ascertained by experience that the wear upon the edges of the blocks is greatest at the joints which run transversely to the axis when the blocks are laid in the usual manner. From the experiments of M. Morin, to ascertain the influence of the shape of stone blocks on the force of traction, it was found that the resistance offered by a pavement of blocks averaging from five to six inches in breadth, measured in the direction of the axis of the roadway, and about nine inches in length, was less than in one of cubical blocks of the ordinary size.

Pavements in cities must be accompanied by *sidewalks* and *crossing-places for foot-passengers*. The sidewalks are made of large flat flagging-stone, at least two inches thick, laid on a form of clean gravel well rammed and settled. The width of the sidewalks will depend on the street being more or less frequented by a crowd. It would, in all cases, be well to have them at least twelve feet wide; they receive a slope, or pitch, of one inch to ten feet, towards the pavement, to convey the surface-water to the side channels. The pavement is separated from the sidewalk by a row of long slabs set on their edges, termed *curb-stones*, which confine both the flagging and paving stones. The curb-stones form the sides of the side channels, and should for this purpose project six inches above the outside paving stones, and be sunk at least four inches below their top surface; they should, moreover, be flush with the upper surface of the sidewalks, to allow the water to run over into the side channels, and to prevent accidents which might otherwise happen from their tripping persons passing in haste.

The crossings should be from four to six feet wide, and be slightly raised above the general surface of the pavement, to keep them free from mud.

**724. Broken-stone Road-covering.** The ordinary road-covering for common roads, in use in this country and Europe, is formed of a coating of stone broken into small fragments, which is laid either upon the natural soil, or upon a paved bottoming of small irregular blocks of stone. In England these two systems have their respective partisans; the one claiming the superiority for road-coverings of stone broken into small fragments, a method brought into vogue

some years since by Mr. McAdam, from whom these roads have been termed *macadamized*; the other being the plan pursued by Mr. Telford in the great national roads constructed in Great Britain within about the same period.

The subject of road-making has within the last few years excited renewed interest and discussion among engineers in France; the conclusion, drawn from experience, there generally adopted is, that a covering alone of stone broken into small fragments is sufficient under the heaviest traffic and most frequented roads. Some of the French engineers recommend, in very yielding clayey soils, that either a paved bottoming after Telford's method be resorted to, or that the soil be well compressed at the surface before placing the road-covering.

The paved bottom road-covering on Telford's plan (Fig. 224), is formed by excavating the surface of the ground to a suitable depth, and preparing the form for the pavement with the precautions as for a common pavement. Blocks of stone of an irregular pyramidal shape are selected for the pavement, which, for a roadway 30 feet in width, should be seven inches thick for the centre of the road, and three inches thick at the sides. The base of each block should not measure more than five inches, and the top not less than four inches.

The blocks are set by the hand, with great care, as closely in contact at their bases as practicable; and blocks of a suitable size are selected to give the surface of the pavement a slightly convex shape from the centre outwards. The spaces between the blocks are filled with chippings of stone compactly set with a small hammer.

A layer of broken stone, four inches thick, is laid over this pavement, for a width of nine feet on each side of the centre; no fragment of this layer should measure over two and a half inches in any direction. A layer of broken stone of smaller dimensions, or of clean coarse gravel, is spread over the wings to the same depth as the centre layer.

The road-covering, thus prepared, is thrown open to vehicles until the upper layer has become perfectly compact; care having been taken to fill in the ruts with fresh stone, in order to obtain a uniform surface. A second layer, about two inches in depth, is then laid over the centre of the roadway; and the wings receive also a layer of new material laid on to a sufficient thickness to make the outside of the roadway nine inches lower than the centre, by giving a slight convexity to the surface from the centre outwards. A coating of

clean coarse gravel, one inch and a half thick, termed a *binding*, is spread over the surface, and the road-covering is then ready to be thrown open to travelling.

The stone used for the pavement may be of an inferior quality, in hardness and strength, to that placed at the surface, as it is but little exposed to the wear and tear occasioned by travelling. The surface-stone should be of the hardest kind that can be procured. The gravel binding is laid over the surface to facilitate the travelling, whilst the under stratum of stone is still loose; it is, however, hurtful, as, by working in between the broken stones, it prevents them from setting as compactly as they would otherwise do.

If the roadway cannot be paved the entire width, it should, at least, receive a pavement for the width of nine feet on each side of the centre. The wings, in this case, may be formed entirely of clean gravel, or of chippings of stone.

For roads which are not much travelled, like the ordinary cross roads of the country, the pavement will not demand so much care; but may be made of any stone at hand, broken into fragments of such dimensions that no stone shall weigh over four pounds. The surface-coating may be formed in the manner just described.

725. In forming a *road-covering of broken stone alone*, the bed for the covering is arranged in the same manner as for the paved bottoming: a layer of the stone, four inches in thickness, is carefully spread over the bed, and the road is thrown open to vehicles, care being taken to fill the ruts, and preserve the surface in a uniform state until the layer has become compact; successive layers are laid on and treated in the same manner as the first, until the covering has received a thickness of about twelve inches in the centre, with the ordinary convexity at the surface.

726. **Gravel Roads.** Where *good gravel* can be procured the road-covering may be made of this material, which should be well screened, and all pebbles found in it over two and a half inches in diameter, should be broken into fragments of not greater dimensions than these. A firm level form having been prepared, a layer of gravel, four inches in thickness, is laid on, and, when this has become compact from the travel, successive layers of about three inches in thickness are laid on and treated like the first, until the covering has received a thickness of sixteen inches in the centre and the ordinary convexity.

The Superintending Engineer of Central Park, of New York City, Mr. W. H. Grant, made experiments upon Telford,



McAdam, and gravel roads in the Park, and he came to the conclusion that the gravel roads, as there constructed, were better for the purposes of park roads than either of the others. (*Journal of the Franklin Institute*, 1867. Vol. 84, p. 233.)

The gravel roads which were constructed by him had a rubble, or broken-stone foundation, over which was passed a very heavy roller; and upon which was placed layers of gravel which were thoroughly rolled. In some cases screened gravel was used, and in others gravel directly from the bed. Paved foundations for receiving the gravel make the road much more durable, although the original cost is considerably increased thereby. Roads of this kind, which are constantly used, should be frequently repaired, and the additional layers of gravel should be thoroughly pressed with a heavy roller. For detailed information, see *Journal of the Franklin Institute*, 1867. Vol. 83, pp. 100, 153, 233, 297 and 391, and Vol. 84, pp. 233 and 311.

727. As has been already stated, the French civil engineers do not regard a paved bottoming as essential for broken-stone road-coverings, except in cases of a very heavy traffic, or where the substratum of the road is of a very yielding character. They also give less thickness to the road-covering than the English engineers of Telford's school deem necessary; allowing not more than six to eight inches to road-coverings for light traffic, and about ten inches only for the heaviest traffic.

If the soil upon which the road-covering is to be placed is not dry and firm, *they compress it by rolling*, which is done by passing over it several times an iron cylinder, about six feet in diameter, and four feet in length, the weight of which can be increased, by additional weights, from six thousand to about twenty thousand pounds. The road material is placed upon the bed, when well compressed and levelled, in layers of about four inches, each layer being compressed by passing the cylinder several times over it before a new one is laid on. If the operation of rolling is performed in dry weather, the layer of stone is watered, and some add a thin layer of clean sand, from four to eight tenths of an inch in thickness, over each layer before it is rolled, for the purpose of consolidating the surface of the layer, by filling the voids between the broken-stone fragments. After the surface has been well consolidated by rolling, the road is thrown open for travel, and all ruts and other displacement of the stone on the surface are carefully repaired, by adding fresh material, and levelling the ridges by ramming.

Great importance is attached by the French engineers to the use of the iron cylinder for compressing the materials of a new road, and to minute attention to daily repairs. It is stated that by the use of the cylinder the road is presented at once in a good travelling condition; the wear of the materials is less than by the old method of gradually consolidating them by the travel; the cost of repairs during the first year is diminished; it gives to the road-covering a more uniform thickness, and admits of its being thinner than in the usual method.

The iron roller is now moved by a locomotive, to which it is attached by a suitable gearing, that admits of reversing, so as to travel backward and forward over the road surface.

**728. Asphaltic Roadways and Sidewalks.** In preparing roadways with an asphaltic surface, the ground or subsoil is first made level crosswise, and very compact, by rolling it with a heavy cylinder. Upon this a bed of hydraulic concrete, consisting of one part in volume of hydraulic mortar, to two and a quarter parts in volume of gravel, is laid to the thickness of two and a half inches. This foundation is allowed to become perfectly hard and dry before the asphalt is laid over it.

The asphaltic rock reduced to powder by the ordinary process is uniformly spread over the concrete bed, the surface of which should be thoroughly dry before receiving the mastic, to the depth of two to two and a half inches. This will produce a layer of packed material varying from one and three-quarters to two inches in thickness.

The packing is done with hot irons or pestles, worked by hand, and applied lightly, so as to produce a uniform smooth surface. After the upper bed is compressed in this manner to a proper thickness, a thin coat of fine dry powder, the siftings of earth or of mineral coal ashes, is spread over the surface to fill up inequalities, and the surface is again smoothed over by a flat-iron, heated nearly to a red heat; and, whilst the asphalt is still hot, it is rolled with polished iron rollers, the lighter, weighing four hundred and forty pounds, being first applied, and then a heavier, weighing three thousand pounds.

In recommencing work on an unfinished portion, the part to which the fresh material is to be joined is first thoroughly cleansed from dust, and hot asphalt poured over it.

For sidewalks the asphaltic rock is reduced to a powder, either by crushing it under rollers or by roasting; this is then sifted through wire gauze, with meshes of one-tenth of

an inch. This powder is thoroughly incorporated with hot mineral tar, in the usual way, in the proportions of about three hundred and thirty pounds of tar to four thousand four hundred pounds of powder. This mixture, termed mastic, can be cast into moulds of suitable size and kept for use.

To one hundred pounds of this mixture five or six pounds of mineral tar are added. A portion, about three per cent. of the mastic, of the mineral tar is first heated in an iron cylinder, and then one-third of the mastic thoroughly incorporated with it by stirring with an iron rod, one per cent. more of the tar is then added, and next another third of the mastic, and the remaining portions are stirred in in like manner. When the whole is melted one-half the gravel is stirred in, and then the remaining half in the same way.

In warm climates the mixture may receive a larger dose of gravel.

When the subsoil is compact and dry a layer of concrete of one inch and a half in thickness is spread over it, and covered by a layer of mortar half an inch thick; and over this, when thoroughly dry, a coat of one inch and six-tenths of the prepared mastic concrete.

When the soil is not hard, it should be rammed or rolled to make it so before receiving the hydraulic concrete, which, in this case, is three inches and a half thick, the other two courses being the same as before.

The mastic, whilst hot, is spread uniformly with wooden trowels over the mortar bed; and before it has cooled fine sand is sifted over the surface.

In some cases, instead of a bed of hydraulic concrete and mortar to receive the mastic concrete, one of hot gravel, mixed up with a small dose of mineral tar, is laid, and over this a layer of concrete mastic, formed of the fine siftings of mineral coal ashes, mixed up with heated mineral tar, is laid to form the top coating. This, in like manner, may receive a sifting of fine sand. Rollers are used in this case to give compactness to the bed and the upper layer.

**729. Materials and Repairs.** The materials for broken-stone roads should be hard and durable. For the bottom layer a soft stone, or a mixture of hard and soft, may be used, but on the surface none but the hardest stone will withstand the action of the wheels. The stone should be carefully broken into fragments of nearly as cubical a form as practicable, and be cleansed from dirt and of all very small fragments. The broken stone should be kept in depots at convenient points along the line of the road for repairs.

Too great attention cannot be bestowed upon keeping the road-surface free from an accumulation of mud and even of dust. It should be constantly cleaned by scraping and sweeping. The repairs should be daily made by adding fresh material upon all points where hollows or ruts commence to form. It is recommended by some that when fresh material is added, the surface on which it is spread should be broken with a pick to the depth of half an inch to an inch, and the fresh material be well settled by ramming, a small quantity of clean sand being added to make the stone pack better. When not daily repaired by persons whose sole business it is to keep the road in good order, general repairs should be made in the months of October and April, by removing all accumulations of mud, cleaning out the side channels and other drains, and adding fresh material where requisite.

The importance of keeping the road-surface at all times free from an accumulation of mud and dust, and of preserving the surface in a uniform state of evenness, by the daily addition of fresh material, wherever the wear is sufficient to call for it, cannot be too strongly insisted upon. Without this constant supervision, the best constructed road will, in a short time, be unfit for travel, and with it the weakest may at all times be kept in a tolerably fair state.

**730. Cross Dimensions of Roads.** A road thirty feet in width is amply sufficient for the carriage-way of the most frequented thoroughfares between cities. A width of forty, or even sixty feet, may be given near cities, where the greater part of the transportation is effected by land. For cross roads and others of minor importance, the width may be reduced according to the nature of the case. The width should be at least sufficient to allow two of the ordinary carriages of the country to pass each other with safety. In all cases, it should be borne in mind that any unnecessary width increases both the first cost of construction, and the expense of annual repairs.

Very wide roads have, in some cases, been used, the centre part only receiving a road-covering, and the wings, termed *summer roads*, being formed on the natural surface of the subsoil. The object of this system is to relieve the road-covering from the wear and tear occasioned by the lighter kind of vehicles during the summer, as the wings present a more pleasant surface for travelling in that season. But little is gained by this system under this point of view; and it has the inconvenience of forming during the winter a large quantity of mud, which is very injurious to the road-covering.

There should be at least one foot-path, from five to six feet wide, and not more than nine inches higher than the bottom of the side channels. The surface of the foot-path should have a pitch of two inches, towards the side channels, to convey its surface-water into them. When the natural soil is firm and sandy, or gravelly, its surface will serve for the foot path; but in other cases the natural soil must be thrown out to a depth of six inches, and the excavation be filled with fine clean gravel.

To prevent the foot-path from being damaged by the current of water in the side channels, its side slope, next to the side channel, must be protected by a facing of good sods, or of dry stone.

As it is of the first importance, in keeping the road-way in a good travelling state, that its surface should be kept dry, it will be necessary to remove from it, as far as practicable, all objects that might obstruct the action of the wind and the sun on its surface. Fences and hedges along the road should not be higher than five feet; and no trees should be suffered to stand on the road-side of the side-drains, for independently of shading the road-way, their roots would in time throw up the road-covering.

**731. Plank-Roads.** Plank-roads were very popular a few years since. The road was carefully graded, then stringers—one on each side—were imbedded in the earth, and upon these were laid planks, three or four inches thick, forming a continuous floor. When the planks are new and well laid this makes a very agreeable road for haulage and for pleasure rides, but when the planks become worn and displaced it makes a very disagreeable road. As a general thing they have been abandoned, except in certain localities where they are maintained on account of peculiar circumstances. A good gravel road has been found to be more profitable, and in the long run makes a much better road. Many plank-roads have been changed to McAdam or to Telford roads.

## II.

### RAILWAYS.

**732.** A *railway*, or *railroad*, is a track for the wheels of vehicles to run on, which is formed of iron bars placed in two parallel lines and resting on firm supports.

**733. Rails.** The iron ways first laid down, and termed *tramways*, were made of narrow iron plates, cast in short

lengths, with an upright flanch on the exterior to confine the wheel within the track. The plates were found to be deficient in strength, and were replaced by others to which a vertical rib was added under the plate. This rib was of uniform breadth, and of the shape of a semi-ellipse in elevation. This form of tramway, although superior in strength to the first, was still found not to work well, as the mud which accumulated between the flanch and the surface of the plate presented a considerable resistance to the force of traction. To obviate this defect, iron bars of a semi-elliptical shape in



Fig. 227—Represents a cross-section *a*, of the fish-bellied rail of the Liverpool and Manchester Railway, and the method in which it is secured to its chair. The rail is formed with a slight projection at bottom, which fits into a corresponding notch in the side of the chair *b*. An iron wedge *c* is inserted into a notch on the opposite side of the chair, and confines the rail in its place.

elevation, which received the name of *edge-rails*, were substituted for the plates of the tramway. The cross-sections of these rails are of the form shown in Fig. 227, the top surface being slightly convex, and sufficiently broad to preserve the tire of the wheel from wearing unevenly. This change in the form of the rail introduced a corresponding one in the tires of the wheels, which were made with a flanch on the interior to confine them within the rails of the track.

The cast-iron edge-rail was found upon trial to be subject to many defects, arising from the nature of the material. As it was necessary to cast the rails in short lengths of three or four feet, the tract presented a number of joints, which rendered it extremely difficult to preserve a uniform surface. The rails were found to break readily, and the surface upon which the wheels ran wore unevenly. These imperfections finally led to the substitution of wrought iron for cast iron.

734. The wrought-iron rails first brought into use received nearly the same shape in cross-section and elevation as the cast-iron rail. They were formed by rolling them out in a rolling-mill so arranged as to give the rail its proper shape. The length of the rail was usually fifteen feet, the bottom of



Fig. 228—Represents a side elevation of a portion of a fish-bellied rail.

it (Fig. 228) presenting an undulating outline so disposed as to give the rail a bearing point on supports placed three feet apart between their centres. This form, known as the *fish-belly* rail, was adopted as presenting the greatest strength for

the same amount of metal. It has been found on trial to be liable to many inconveniences. The rails break at about nine inches from the supports, or one fourth of the distance between the bearing points, and from the curved form of the bottom of the rail they do not admit of being supported throughout their length.

735. The form of rail at present in most general use is known by the name of the *parallel*, or *straight* rail, the top and bottom of the rail being parallel; or as the T, or H rail, from the form of the cross-section.

A variety of forms of cross-section are to be met with in the parallel rail. The more usual form is that (Fig. 229) in

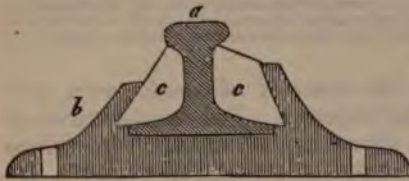

Fig. 229—Represents a cross-section *a* of a parallel rail of the form generally adopted in the U. States. The rail may be confined to its chair *b* by two wooden keys *c* on each side, which are formed of hard compressed wood. At the present time two iron straps are used instead of the keys *c*, which are firmly bolted to the rails. This form is called a fish-joint. In this case the projection *b* is omitted. A very great variety of *splices* are in use.

which the top is shaped like the same part in the fish-belly rail, the bottom being widened out to give the rail a more stable seat on its supports. In some cases the top and bottom are made alike to admit of turning the rail. The greatest deviation from the usual form is in the rail of the Great Western Railway in England (Fig. 230), and the Grand Trunk in Canada; but this form is rapidly going out of use.



Fig. 230—Represents a cross-section of the rail of the Great Western Railway in England. This rail is laid on a continuous support, and is fastened to it by screws on each side of the rail. A piece of tarred felt was inserted between the base of the rail and its support.

The dimensions of the cross-section of a rail should be such that the deflection in the centre between any two points of support, caused by the heaviest loads upon the track, should not be so great as to cause any very appreciable increase of resistance to the force of traction. The greatest deflection, as laid down by some writers, should not exceed three-hundredths of an inch for the usual bearing of three feet between the points of support. The top of the rail is usually about two and a half inches broad, and an inch in depth. This has been found to present a good bearing surface for the wheels, and sufficient strength to prevent the top from being crushed

by the weight upon the rail. The thickness of the rib varies between half an inch to three-fourths of an inch; and the total depth of the rail from three to five inches. The thickness and breadth of the bottom have been varied according to the strength and stability demanded by the traffic.

**736. Steel Rails.** Rails made entirely of *steel*, or of wrought iron, with a thin bar of steel forming the top surface, or *steel-top*, or *steel-headed* rails as they are termed, from their superior strength and durability, are coming into general use in replacing the worn-out wrought-iron rails of old roads. Steel obtained from any of the usual processes, either cast, puddled, or Bessemer steel, may be used for the steel heads of rails.

From the experience of Swedish engineers it appears that solid Bessemer steel rails of the best charcoal pig-iron may be made 10 per cent. lighter than the best English wrought-iron rails, a result which has been carried into practice on the Austrian railways.

The durability of iron rails appears to depend principally upon the perfection of the welding, the chief cause of their want of durability arising from the lamination caused by imperfect welding.

Formerly wrought-iron rails were made partly by hammering and partly by rolling. At present rolling alone is used, and the results are said to be more satisfactory, whilst the process of manufacture is more simple.

The resistance to wear of rails, from English experience, it is said, may be measured by the product of the speed and of the weight passing over them. The rule proposed for the work that rails may be subjected to is 220,000,000 tons transported at the rate of one mile per hour. The length of time that iron rails will last in any given case will be found by multiplying the number of tons transported by the rate of speed per hour and dividing by 220.

**737. Supports.** The rails are laid upon supports of timber or stone. The supports should present a firm, unyielding bed to the rails, so as to prevent all displacement, either in a lateral or a vertical direction, from the pressure thrown upon them.

Considerable diversity is to be met with in the practice of engineers on this point. On the earlier roads, heavy stone blocks were mostly used for supports, but these were found to require great precautions to render them firm, and they were, moreover, liable to split from the means taken to confine the rails to them. Timber is generally preferred to stone. It



affords a more agreeable road for travel, and gives a better lateral support to the rails than stone blocks, and the wear upon the locomotive and other machinery is less severe.

The usual method of placing timber supports is transversely to the track, each support, termed a *sleeper*, or *cross-tie*, being formed of a piece of timber six or eight inches square. The ordinary distance between the centre lines of the supports is three feet for rails of the usual dimensions. With a greater bearing, rails of the ordinary dimensions do not present sufficient stiffness. The sleepers, when formed of round timber, should be squared on the upper and lower surface. On some of the recent railways in England, sleepers presenting in cross section a right-angled triangle have been used, the right angle being at the bottom. They are represented to be more convenient in setting, and to offer a more stable support than those of the usual form. The sleepers are placed either upon the ballasting of the roadway, or upon longitudinal beams laid beneath them along the line of the rails. The latter is indispensable upon new embankments to prevent the ends of the sleepers from settling unequally. Thick plank, about eight inches broad and three or four inches thick, is usually employed for the longitudinal supports of the sleepers.

On some of the more recent railways in England, the rails have been laid upon longitudinal beams, presenting a continuous support to the rail, the beams resting upon cross-ties.

**738. Ballast.** A covering of broken stone, of clean coarse gravel, or of any other material that will allow the water to drain off freely, is laid upon the natural surface of the excavations and embankments, to form a firm foundation for the supports. This has received the appellation of the *ballast*. Its thickness is from nine to eighteen inches. Open or broken-stone drains should be placed beneath the ballasting to convey off the surface water. The parts of the ballasting upon which the supports rest should be well rammed, or rolled; and it should be well packed beneath and around the supports. After the rails are laid, another layer of broken stone or gravel should be added, the surface of which should be slightly convex and about three inches below the top of the rails.

**739. Temporary Railways of Wood and Iron.** On the first introduction of railways into the United States, the tracks were formed of flat iron bars laid upon longitudinal beams. The iron bars were about two and a half inches in breadth, and from one-half to three-fourths of an inch in thickness, the top surface being slightly convex. They were placed on the

longitudinal beams, a little back from the inner edge, the side of the beam near the top being bevelled off, and were fastened to the beam by screws or spikes, which passed through elliptical holes with a countersink to receive the heads of the spikes; the holes receiving this shape to allow of the contraction and expansion of the bar, without displacing the fastenings. The longitudinal beams were supported by cross sleepers, with which they were connected by wedges that confined the beams in notches cut into the sleepers to receive them. The longitudinal beams were usually about six inches in breadth, and nine inches in depth, and in as long lengths as they could be procured. The joints between the bars were either square or oblique, and a piece of iron or zinc was inserted into the beams at the joint, to prevent the end of the rail from being crushed into the wood by the wheels.

In some instances the bars were fastened to long stone blocks, but this method was soon abandoned, as the stone was rapidly destroyed by the action of the wheels; besides which, the rigid nature of the stone rendered the travelling upon it excessively disagreeable.

This system of railway, whose chief recommendation is economy in the first cost, has gradually given place to the solid rail. Besides the want of durability of the structure, it does not possess sufficient strength for a heavy traffic.

**740. Gauge.** The distance between the two lines of rails of a track, termed the *gauge*, which has been adopted for the great majority of the railways in England, and also with us, is 4 feet 8½ inches. This gauge appears to have been the result of chance, and it has been followed in the great majority of cases up to the present time, owing to the inconvenience that would arise from the adoption of a different gauge upon new lines. The greatest deviation yet made from the established gauge is in that of the Great Western Railway, in which the gauge is seven feet. Engineers are generally agreed that with a wider gauge the wheels of railway cars could be made of greater diameter than they now receive, and be placed outside of the cars instead of under them as at present; the centre of gravity of the load might be placed lower, and more steadiness of motion and greater security at high velocities be attained. All roads having a gauge above 4 feet 8½ inches are inclined rather to reduce them to that gauge or use a third rail so as to run the cars of that gauge over their own.

Within the last four or five years the subject of roads of *very narrow gauge* has been much discussed. The advan-

tages principally claimed for roads of this kind are: 1st, great reduction in first cost; 2d, allowing steeper grades and curves of smaller radius; 3d, less wear and tear on the road on account of the rolling stock being much lighter; 4th, the ratio of live to dead weight is much less. Some lines have been made with a  $2\frac{1}{2}$ -foot gauge, but the advocates of narrow gauge generally recommend a 3-foot gauge. The latter is the gauge of the Denver and Texas narrow-gauge road.

In a double track the distance between the two tracks is generally the same as the gauge; and the distance between the outside rail of a track, and the sides of the excavation, or embankment, is seldom made greater than six feet, as this is deemed sufficient to prevent the cars from going over an embankment were they to run off the rails.

741. On all straight portions of a track, the supports should be on a level transversely, and parallel to the plane of the track longitudinally. The top surface of the rail should incline inward, to conform to the conical form of the wheels; this is now usually effected by giving the chair the requisite pitch, or by forming the top surface with the requisite bevel for this purpose.

742. *Curves.* In the curved portions of a track the centrifugal force tends to force the carriage towards the outside rail of the curve, and by elevating the outer rail the force of gravity tends to draw it towards the inside rail. From the above conditions of equilibrium the elevation which the exterior rail should receive above the interior can be readily calculated. The method adopted is to give the exterior rail an elevation sufficient to prevent the flanch of the wheel from being driven against the side of the rail when the car is moving at the highest supposed velocity; or, in other words, to give the inclined plane across the track, on which the wheels rest, an inclination such that the tendency of the wheels to slide towards the interior rail shall alone counteract the centrifugal force.

743. *Sidings, etc.* On single lines of railways short portions of a track, termed *sidings*, are placed at convenient intervals along the main track, to enable cars going in opposite directions to cross each other, one train passing into the siding and stopping while the other proceeds on the main track. On double lines arrangements, termed *crossings*, are made to enable trains to pass from one track into the other, as circumstances may require. The position of sidings and their length will depend entirely on local circumstances, as the length of the trains, the number daily, etc.

The manner generally adopted, of connecting the main track with a siding, or a crossing, is very simple. It consists (Fig. 231) in having two short lengths of the opposite rails

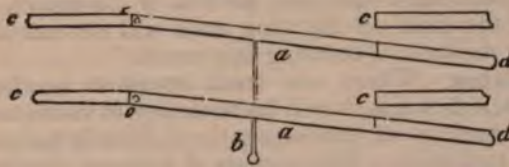

Fig. 231—Represents the sliding switches, or rails, for connecting a siding with the main track.

a, a, rails connected by an iron rod b, by which they can be turned around the joints o, o.  
c, c, rails of main track.  
d, d, rails of siding.

of the main track, where the siding or crossing joins it, movable around one of their ends, so that the other can be displaced from the line of the main track, and be joined with that of the siding, or crossing, on the passage of a car out of the main track. These movable portions of rails are connected and kept parallel by a long cross-bolt, to the end

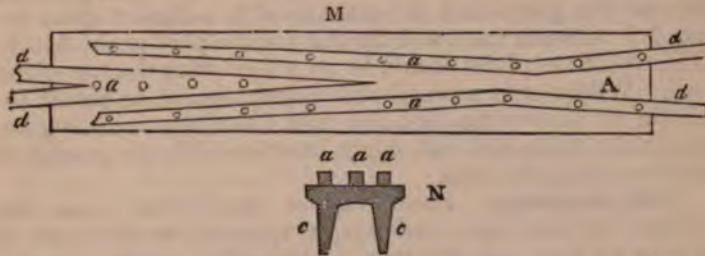

Fig. 232—Represents a plain M, and section N, of a fixed crossing plate. The plate A is of cast-iron, with vertical ribs c, c, on the bottom, to give it the requisite strength. Wrought-iron bars a, a, placed in the lines of the two intersecting rails d, d, are firmly screwed to the plate; a sufficient space being left between them and the rails for the flanch of the wheel to pass.

of which a vertical lever is attached to draw them forward, or shove them back.

At the point where the rails of the two tracks intersect, a cast-iron plate, termed a *crossing-plate* (Fig. 232), is placed to connect the rails. The surface of the plate is arranged either with grooves in the lines of the rails to admit the flanch of the wheel in passing, the tire running upon the surface of the plate; or wrought-iron bars are affixed to the surface of the plate for the same purpose.

The angle between the rails of the main tracks and those of a siding or crossing, termed the *angle of deflection*, should not be greater than  $2^\circ$  or  $3^\circ$ . The connecting rails between

the straight portions of the tracks should be of the shape of an S curve, in order that the passage may be gradually effected. At the present time switch rails and frogs of peculiar construction are in use, which are so made and arranged as to leave the main track unbroken, so that if the switch is wrongly placed the train on the main track will not run off. There are many devices for securing this result.

**744. Turn-plates.** Where one track intersects another under a considerable angle, it will be necessary to substitute for the ordinary method of connecting them, what is termed a *turn-plate*, or turn-table. This consists of a strong circular platform of wood or cast iron, movable around its centre by means of conical rollers beneath it running upon iron roller-ways. Two rails are laid upon the platform to receive the car, which is transferred from one track to the other by turning the platform sufficiently to place the rails upon it in the same line as those of the track to be passed into.

**745. Street crossings.** When a track intersects a road, or street, upon the same level with it, the rail must be guarded by cast-iron plates laid on each side of it, sufficient space being left between them and the rail for the play of the flanch. The top of the plates should be on a level with the top of the rail. Wherever it is practicable a drain should be placed beneath, to receive the mud and dust which, accumulating between the plates and rail, might interfere with the passing of the cars along the rails.

**746. Gradients.** From various experiments upon the friction of cars upon railways, it appears that the angle of repose is about  $\frac{1}{20}$ , but that in descending gradients much steeper, the velocity due to the accelerating force of gravity soon attains its greatest limit and remains constant, from the resistance caused by the air.

The limit of the velocity thus attained upon gradients of any degree, whether the train descends by the action of gravity alone, or by the combined action of the motive-power of the engine and gravity, can be readily determined for any given load. From calculation and experiment it appears that heavy trains may descend gradients of  $\frac{1}{10}$ , without attaining a greater velocity than about 40 or 50 miles an hour, by allowing them to run freely without applying the brake to check the speed. By the application of the brake, the velocity may be kept within any limit of safety upon much steeper gradients. The only question, then, in comparing the advantages of different gradients, is one of the comparative cost between the loss of power and speed, on the one hand, for

ascending trains on steep gradients, and that of the heavy excavations, tunnels, and embankments on the other, which may be required by lighter gradients.

In distributing the gradients along a line, engineers are generally agreed that it is more advantageous to have steep gradients upon short portions of the line, than to overcome the same difference of level by gradients less steep upon longer developments.

747. *In steep gradients*, where locomotive power cannot be employed, stationary power is used, the trains being dragged up, or lowered, by ropes connected with a suitable mechanism, worked by stationary power placed at the top of the plane. The inclined planes, with stationary powers, generally receive a uniform slope throughout. The portion of the track at the top and bottom of the plane should be level for a sufficient distance back, to receive the ascending or descending trains. The axes of the level portion should, when practicable, be in the same vertical plane as that of the axis of the inclined plane.

Small rollers, or sheeves, are placed at suitable distances along the axis of the inclined plane, upon which the rope rests.

Within a few years back flexible bands of rolled hoop-iron have been substituted for ropes on some of the inclined planes of the United States, and have been found to work well, presenting more durability and being less expensive than ropes.

On very steep gradients the expedient of a third rail in the centre of the track, and raised rather above the plane of the other two rails, has been used. Two horizontal wheels underneath the locomotive run on this rail, and may be tightened to any desirable degree of compression on it. In this way a gradient of 440 feet per mile is used over Mont Cenis. Without the intermediate rail grades as steep as 280, and in one case 304 feet per mile, have been ascended by means of the adhesive power of the locomotive only. But such grades will never be sought; on the other hand, they will be avoided when possible. Grades of 50 and 60 feet to the mile are very common. The maximum grade allowable by law on the Central Pacific Railroad is the same as that of the Baltimore and Ohio Railroad, viz., 116 feet per mile.

748. *Tunnels.* The choice between deep cutting and tunnelling, will depend upon the relative cost of the two, and the nature of the ground. When the cost of the two methods

would be about equal, and the slopes of the deep cut are not liable to slips, it is usually more advantageous to resort to deep cutting than to tunnelling. So much, however, will depend upon local circumstances, that the comparative advantages of the two methods can only be decided upon understandingly when these are known.

749. **The operations in Tunnelling** will depend upon the nature of the soil. The work is commenced by setting out, in the first place, with great accuracy upon the surface of the ground, the profile line contained in the vertical plane of the axis of the tunnel. At suitable intervals along this line vertical pits, termed *working shafts*, are sunk to a level with the top, or crown of the tunnel. The shafts and excavations, which form the entrances to the tunnel, are connected, when the soil will admit of it, by a small excavation termed a *heading*, or *drift*, usually five or six feet in width, and seven or eight feet in height, which is made along the crown of the tunnel. After the drift is completed, the excavation for the tunnel is gradually enlarged; the excavated earth is raised through the working shafts, and at the same time carried out at the ends. The dimensions and form of the cross section of the excavation will depend upon the nature of the soil and the object of the tunnel as a communication. In solid rock the sides of the excavation are usually vertical; the top receives an arched form; and the bottom is horizontal. In soils which require to be sustained by an arch, the excavation should conform as nearly as practicable to the form of cross section of the arch.

In tunnels through unstratified rocks, the sides and roof may be safely left unsupported; but in stratified rocks there is danger of blocks becoming detached and falling; wherever this is to be apprehended, the top of the tunnel should be supported by an arch.

Tunnelling in loose soils is one of the most hazardous operations of the miner's art, requiring the greatest precautions in supporting the sides of the excavations by strong rough framework, covered by a sheathing of boards, to secure the workmen from danger. When in such cases the drift cannot be extended throughout the line of the tunnel, the excavation is advanced only a few feet in each direction from the bottom of the working shafts, and is gradually widened and depended to the proper form and dimensions to receive the masonry of the tunnel, which is immediately commenced below each working shaft, and is carried forward in both directions towards the two ends of the tunnel.

**750. Masonry of Tunnels.** The cross section of the arch of a tunnel (Fig. 233) is usually an oval segment, formed of



Fig. 233—Represents the general form of the cross section *c* of a brick arch for tunnels.  
*a, a*, askew-back stone between the sides of the arch and the bottom inverted arch.

arcs of circles for the sides and top, resting on an inverted arch at bottom. The tunnels on some of the recent railways in England are from 24 to 30 feet wide, and of the same height from the level of the rails to the crown of the arch. The usual thickness of the arch is eighteen inches. Brick laid in hydraulic cement is generally used for the masonry, an askew-back course of stone being placed at the junction of the sides and the inverted arch. The masonry is constructed in short lengths of about twenty feet, depending, however, upon the precautions necessary to secure the sides of the excavation. As the sides of the arch are carried up, the framework supporting the earth behind is gradually removed, and the space between the back of the masonry and the sides of the excavation is filled in with earth well rammed. This operation should be carefully attended to throughout the whole of the backing of the arch, so that the masonry may not be exposed to the effects of any sudden yielding of the earth around it.

**751.** The earth at the ends of the tunnel is supported by a retaining wall, usually faced with stone. These walls, termed the *fronts* of the tunnel, are generally finished with the usual architectural designs for gateways. To secure the ends of the arch from the pressure of the earth above them, cast-iron plates of the same shape and depth as the top of the arch, are inserted within the masonry, a short distance from



the ends, and are secured by wrought-iron rods firmly anchored to the masonry at some distance from each end.

752. The working shafts, which are generally made cylindrical and faced with brick, rest upon strong curbs of cast iron, inserted into the masonry of the arch. The diameter of the shaft within is ordinarily nine feet.

753. The ordinary difficulties of tunnelling are greatly increased by the presence of water in the soil through which the work is driven. Pumps, or other suitable machinery for raising water, placed in the working shafts, will in some cases be requisite to keep them and the drift free from water until an outlet can be obtained for it at the ends, by a drain along the bottom of the drift. Sometimes, when the water is found to gain upon the pumps at some distance above the level of the crown of the tunnel, an outlet may be obtained for it by driving above the tunnel a drift-way between the shafts, giving it a suitable slope from the centre to the two extremities to convey the water off rapidly.

In tunnels for railways, a drain should be laid under the balasting along the axis, upon the inverted arch of the bottom.

Tunnelling in rock is greatly facilitated at the present day by power-drilling-machines, which are driven by compressed air. By this means they are able to advance three times as fast as by hand labor. The compressed air greatly facilitates ventilation. The Mont Cenis tunnel (nearly 7 miles long) and the Hoosac tunnel (about 4 miles long) have been driven in this way, and the St. Godard tunnel (nearly 13 miles long) is now in process of construction on the same plan.

754. The following extracts are made from a series of papers, published in the *London Engineering*, from Oct. 7, 1870, to December 30, 1870, giving a translation of a work by Baron von Weber, Director of the State Railways of Saxony, with running comments by the translator, detailing the experiments made by the author, and giving his deductions from them, on the *Stability of the Permanent Way*.

Baron von Weber desired, in the first place, to ascertain what was the *minimum* thickness which would be given to the web of a rail, in order that the latter might still possess a greater power of resistance to lateral forces than the fastenings by which it was secured to the sleepers.

755. **Resistance of Rail to Lateral Forces.** From the experiments the result was deduced, that the least thickness ever given to the webs of rails in practice is more than sufficient, and that if it were possible to roll webs  $\frac{1}{4}$  in. thick, such webs would be amply strong, if it were not that there

would be a chance of their being torn at the points where they are traversed by the fish-plate bolts. Baron von Weber concludes that webs  $\frac{3}{8}$  in. or  $\frac{1}{2}$  in. thick are amply strong enough for rails of any ordinary height, and that in fact the webs should be made as thin as the process of rolling, and as the provision of sufficient bearing for the fish-plate bolts will permit.

**756. Stability of the Permanent Way.** The stability of a permanent way structure in a longitudinal direction, is considered by Baron von Weber as depending upon the bedding of the sleepers in the ballast, the friction of the rails upon the sleepers, the strength of the spikes or other fastenings, and, lastly, upon the strength of the connections between the ends of the rails. These connections have, in the first place, to keep the heads of the rails in their proper position with regard to each other; next, to give to the joint a certain amount of rigidity; and finally, to insure that the horizontal or vertical deflections of the two rails connected take place together. Of the many forms of connections which have from time to time been proposed for rails, but two practically fulfil the conditions just mentioned, these two being the joint chair and the fish-joint, in their various modifications and forms.

We now come to the researches made by Baron von Weber to determine the power of permanent way structures to resist forces tending to displace the entire system. Baron von Weber states that as the speed of trains was increased on German railways, there was noticed a peculiar and dangerous displacement of the permanent way, this displacement taking place chiefly where trains pass from straight to curved portions of the line, or from curved portions to level and straight lengths, over which they passed at an increased speed. It was also observed that the displacements at the first-mentioned points—displacements which consisted in the shifting of the line towards the convex side of the curves—were caused principally by engines having long wheel bases and a comparatively light load on the leading wheels; while the displacement of the straight portions of the lines was due mainly to the action of powerful engines with short wheel bases and considerable overhang on each end. In this latter case the horizontal oscillations which produced the displacements were almost always found to arise from the effect of vertical impact due to a loose joint or some local settlement in the line, the engine being thus not merely caused to lurch heavily sideways, but being also made to oscillate in a vertical plane, thus alternately relieving and increasing the loads on the leading

and trailing wheels. Under these circumstances, when the flange of the leading wheel struck the rail laterally at the same time that the load on the latter was decreased by the momentary relief of the leading wheel from a portion of the weight it ought to carry, there was a greater displacement than there otherwise would have been owing to the diminished friction between the permanent way structure and its foundation. Both the classes of displacements to which we have referred were found to be less in permanent way structures possessing considerable vertical rigidity than in those of a more flexible character.

**757. Experiments on the Power of Permanent Way-structures to resist Horizontal Displacements of the entire System.** These experiments were made to obtain answers to the five following questions:—

*a.* What is the resistance offered by a well-bedded sleeper of average size against lateral displacement in the ballast?

*b.* What is the resistance of the whole structure against displacement at one point, and what is the influence of the ballast and bedding, on and in which the structure rests, upon this resistance?

*c.* How far does the filling against the ends of the sleepers increase this resistance?

*d.* To what extent is the resistance to lateral displacement increased by the load on the structure?

*e.* How far does the application of piles or stones, etc., etc., increase this resistance?

The deductions to be made from the experiments referring to questions *a* and *b*, Baron von Weber considers to be as follows: 1st. The resistance of unloaded well-bedded permanent way-structures is comparatively small, a lateral pressure of from 30 to 50 centners being sufficient to break the connection between the sleeper and the ground. This pressure is less than that which would be exerted by the centrifugal force due to the passage of a 25-ton locomotive through a curve of 1,000 feet radius, at a speed of 30 miles per hour, supposing that this centrifugal force was not counteracted by superelevation of the exterior rail. 2d. The nature of the ballast in which the sleepers of unloaded permanent way-structures are bedded has no important influence on the resistance to lateral displacement. 3d. The pressure requisite for producing the horizontal displacement of an unloaded structure increases until this displacement has reached a certain amount, generally between 12 and 18 millimetres (from 0.472 in. to 0.708 in.), when the further displacement

up to 50 to 75 millimetres (2 in. to 3 in.) is produced without any considerable augmentation in the pressure, until finally a considerable tension is set up in the different parts of the structure.

Baron von Weber's conclusions from the experiments referring to question *c* are as follows: 1st. That the filling of ballast against the ends of the sleepers, up to the top surface of the latter, has an insignificant influence upon the resisting power of the structure to lateral displacement, particularly if the structure is unloaded, and if a one-sided tilting is possible. 2d. That if the ballast is not filled against the ends of the sleepers, the elasticity of the rails will bring back the structure into its original position, on the removal of the pressure, even after considerable displacement, as in this case small portions of ballast cannot fall between the end of the shifted sleeper and the undisturbed end filling, as is the case when the practice of filling up against the ends is followed.

We now come to the experiments made by Baron von Weber to obtain an answer to question *d*. It was, of course, requisite, in order that a proper comparison might be instituted, that these experiments should be conducted under circumstances as nearly as possible identical with those which existed when the resistance of displacement of the unloaded structure was investigated; and in selecting portions of permanent way for the last-mentioned experiments, therefore, such lengths were chosen as would afford space for the experiments with the loaded structure, without introducing any variations in bedding, firmness of the ballast, etc., etc.

The results of seven sets of trials show that the resistance of the structure to lateral displacement was increased almost tenfold by the load of twenty-seven tons; and that lateral pressures which produced in the unloaded structure displacements entirely inadmissible in practice, did not affect the loaded structure in any perceptible degree. The portion of the unloaded structure shifted by the press in the above experiments weighed almost exactly  $2\frac{1}{2}$  tons, while the total mass moved, including the filling against the ends of the sleepers, weighed 3 tons; and taking this into consideration, it appeared as if the resistance to displacement varied directly—as indeed it might have been supposed it would do—as the weight resting on the ground.

Baron von Weber's conclusion with regard to this subject is, that the force required to produce the lateral displacement of a permanent way-structure is directly proportionate

to the weight by which the structure is pressed upon the ground.

758. **Experiments relating to Question e.** In considering the influence of piles or stakes driven into the ballast against the ends of the sleepers to prevent lateral shifting of the latter, Baron von Weber remarks that the resisting power of such piles has been very differently "estimated" by railway engineers, but that as far as he is aware the advantages or disadvantages attending the use of such piles has never been ascertained by experiment. Many elements evidently exercise an influence on the lateral displacement of piles driven vertically into the ground, and experiments made with a view of ascertaining the lateral resistance of such piles can only show in a very general manner how far the advantages derived from their use will counterbalance the extra expense they involve. The results obtained by experiment are moreover liable to great variations. Thus, a pile driven deeply into solid, loamy soil, offers in dry weather great resistance to lateral displacement, whereas after a shower of rain—not strong enough to soak into the ground, but capable of penetrating the narrow crack formed between the pile and surrounding earth by the vibrations caused by the traffic—the upper end of the pile can be moved, by the application of a comparatively small force, to an extent sufficient to render it useless as a means of lateral support for the sleeper. Thus Baron von Weber has found that piles which, in dry weather, require a force of from 15 to 20 cwt. to shift their heads laterally through a distance of one inch, could be moved to the same extent by the force of about 5 cwt. after a shower of rain lasting barely one hour.

The elements by which the lateral stability of such piles as those we are now considering is affected are: the diameter, length, and section of the pile, the description of wood of which it is made, and the nature of ground into which it is driven. To determine the influence of all these elements in their various combinations a very extensive series of experiments would have been required, and Baron von Weber therefore confined his researches to ascertaining the maximum resistance of such stakes as are used on the Saxon state railways, availing himself, however, of all available opportunities of noticing the resistance under unfavorable circumstances.

The principle was laid down that a displacement of the top of a pile to the extent of 10 millimetres (= 0.39 in.) should be considered as inconsistent with its further usefulness.

In this series of trials the pressure acted against a number of oak stakes, some of round and some of square section, and varying from 2 ft. 11½ in. to 3 ft. 11¼ in. long. The ground was solid sand or mixed gravel, and some of the stakes had been in use for a considerable time, while others were driven expressly for the experiments. The results showed that a pressure of from 3 cwt. to 5 cwt. was quite sufficient to produce the lateral displacement of 10 millimetres (=0.39 in.) whilst a pressure of 7 cwt. almost forced the stakes out of the ground. These experiments showed, therefore, that in ground of this kind piles driven against the ends of the sleepers could not exercise the least influence upon the stability of the permanent way-structure.

In these trials the pressure acted against a pile 4 in. in diameter and 2 ft. 11½ in. long, driven into a heavy loamy ballast, which had been laid down about ten years over the broken-stone bedding of an old line. The results which we subjoin show that the resisting power of such a pile would be of but little use for increasing the lateral stability of the structure.

Three trials were made on a pile 4 in. square and 4 ft. 11 in. long, driven into the same ground as the pile tested in the last series of experiments.

The results showed that the length and section of the pile exercise an important influence on its resistance to lateral pressure. It was found in these last two series of experiments that when the displacement of the piles became great, the ground behind them cracked radially and rose considerably; while, when the cracks reached certain dimensions, it was found that no increase of pressure was required to produce a further displacement of the piles.

Baron von Weber's conclusions, drawn from the experiments relating to question *e*, are as follows: 1st. That the resistance of piles driven into sandy or other light ground is so insignificant that the use of such piles under such circumstances will not produce an increased stability of the structure against lateral displacement; 2d. That the resistance of piles driven into heavy solid ground is much greater than that of piles driven into sandy ground; but that even in the former case the piles must be driven rather closely if they are to afford any efficient resistance to small lateral displacements of the permanent way-structure; 3d. The resisting power of piles, and especially their resistance to small displacements, increasing with their length, and in a more rapid ratio than the latter, it is considered that no piles, to produce an effect

commensurate with their cost, should have a length of less than 5 ft.; and 5th. The signs of considerable displacements of piles may, under certain circumstances, disappear after the causes of these displacements have been removed, without, however, the piles regaining their former stability.

**759. Experiments to determine the power of permanent way-structures to resist the loosening of the rails from the sleepers.** It is remarked by Baron von Weber that in investigating the stability of the connection between rails and sleepers, it has to be borne in mind that the resistance of the rails to displacement depends upon three things, viz.: First, the holding power of the fastenings (bolts, spikes, etc., etc.) by which the rails are secured to the sleepers; second, to the increased friction between the base of the rails and the sleepers which is caused by a load standing on the rails; and, third, by the friction between the rails and the wheels, this friction causing the axles to form ties between the two lines of rails on which their wheels rest. It will thus be seen that the gauge of a line of rails is preserved not merely by the fastenings securing the rails to the sleepers, but also by other forces of considerable importance acting both on the top and bottom of the rails.

The passage of the rolling stock is considered by Baron von Weber to produce on the rails the following effects:—

1. Under all circumstances a vertical pressure tending to force the rails into the sleepers, the latter yielding to this force in all cases where they are not made of materials of very high resisting powers, such as stone or iron. Wooden sleepers are of course compressed by the vertical pressure of the trains, and one point to be determined, therefore, is—

**760. (e) To what extent are sleepers of various forms and materials compressed by the loads acting on the rails?**

2. There is a horizontal pressure resulting, in the case of curves, partly from centrifugal force and partly from the rigidity of the rolling stock, and, in the case of straight lines, from the oscillation of the vehicles. This horizontal pressure—which may, however, change into a pressure acting at a more or less acute angle to the surface of the sleepers—tends to alter the position of the rail on the sleeper in two ways, namely: first, by shifting the rail on the sleeper without altering the inclination of the former; and, second, by canting the rail and causing it to turn on a point situated more or less near to its outer edge, according to the compressibility of the sleeper. The first of these two kinds of displacement is resisted by the horizontal resistance of the

spikes or other fastenings, by the friction between the wheel and the rail, and by the friction between the base of the rail and the sleeper, and the question to be answered by the experiments relating to this kind of displacement, therefore, is—

761. (*f*) *What power is required to displace a fastened and loaded rail horizontally on its sleepers?*

The second kind of displacement just mentioned, or canting of the rails outwards, is resisted by the direct holding power of the fastenings connecting the rail to the sleeper, and by the friction between the wheel and rail. The questions to be answered by the investigations relating to this matter, therefore, are—

(*g*) *What force is required to draw the spikes out of the sleepers?* and

(*h*) *What force is required to overcome the combined resistance due to the holding power of the spikes in the sleepers, and the friction between the rails and wheels?*

The following sets of experiments were carried out by Baron von Weber, in order to obtain answers to the above questions:—

The most striking result obtained is the deterioration of the sleepers under the influence of the traffic at the points where the rails rest upon them. Thus it will be seen that in the case of the fir sleepers the average compressions under the load, at the unused and old bearing surfaces respectively, were 5.3 and 9.7 mils.; while the average permanent compressions were 1.1 and 2.6 mils., the latter results being about double the former.

Another remarkable result is the actual amount of the compression, this amount averaging as much as 5.3 millimetres (= 0.208 in.) for new and sound fir sleepers, and 9.7 millimetres (= 0.382 in.) for fir sleepers averaging five years old. Baron von Weber considers that these results point to the necessity of employing rigid rails, so as to distribute the effects of the pressure of the rolling stock as far as possible over a number of supports, and that they also show the advantage of employing sleepers of hard timber.

The results of the first group of experiments relating to question (*e*) Baron von Weber summarizes as follows:—

1. That sound fir sleepers 140 millimetres (= 5.5 in.) thick and 200 millimetres (= 7.87 in.) wide are compressed, on an average, one millimetre (0.039 in.) by a load of 5.6 kilogrammes per square centimetre (= 79.6 lb. per square inch), it being supposed that they have not before been subjected to



such a load. At places where rails have already been bearing upon the sleepers for some time, this compression is increased to one millimetre for each load of 4 kilogrammes per square centimetre (=56.88 lb. per square inch).

2. The action of the trains increases considerably the compressibility of the sleepers at the points where the rails bear upon them.

3. That the compressibility of wooden sleepers—and especially of fir sleepers—is so great, that it is necessary to distribute the pressure of the trains upon the sleepers as far as possible by the employment of rigid rails.

4. That increasing the number of sleepers in order to increase the carrying power of a permanent way, is, theoretically and economically, a wrong mode of obtaining that end.

5. That in the event of lateral pressure being brought to bear against the head of the rail, the resisting power of fir sleepers is not sufficiently great to prevent a canting of the rail consequent upon the impression of one side of the base into the sleeper. Hence momentary alterations in the gauge are allowed, these alterations disappearing, however, on the removal of the lateral pressure, and leaving no traces on the spikes, sleepers, or rails.

6. The compression of fir sleepers under the bases of the rails is so great that the cellular structure of the wood is slowly destroyed, and a cutting or indentation of the sleepers at the points of bearing takes place, this action being accelerated when the upper fibres of the wood have been more or less deprived of their elasticity by the action of the weather.

The above conclusions are justified by Baron von Weber's further investigations.

Baron von Weber's deductions from the second group of experiments relating to question (e) are as follows:—

1. When the influence of the rigidity of the rail, etc., upon the transference of the pressure of the rolling load to the sleeper is taken into account, it may be considered that the compression of the sleeper itself takes place in the same manner under the action of either a steadily applied or a rolling load.

2. That the sinking of well-bedded sleepers into the ground on which they rest is proportionately insignificant even under the action of considerable rolling stock.

3. That if the base of the rail has a bearing surface of 220 square centimetres (= 32½ square inches) upon a sound fir sleeper between four and six years old, and 140 millimetres

(= 5.5 inches) thick, a load of 1,500 kilogrammes applied through the rail will compress the sleeper one millimetre. Or, in other words, a load of about 7 kilogrammes per square centimetre (= 99.54 lb. per square inch) will produce the compression just mentioned on those parts of the sleepers which have already been frequently exposed to that during a considerable time.

Although the series of experiments we have just described are not extensive, Baron von Weber considers that the following deductions may be drawn from them: 1st. That the resistance of the spikes to the horizontal displacement of the rails upon the sleepers is proportionately so insignificant that most of the movements of the rolling stock which would be capable of producing a displacement of the rails on the sleepers would suffice to overcome this resistance; and, 2d. That the power of resistance of the spikes to horizontal displacement decreases, after that displacement has once begun, in a more rapid ratio than the displacement itself increases; and hence that the continued action of the rolling stock will produce generally greater displacements than a sudden and great pressure or force.

**762. Herr Funk's Experiments on the Resisting Power of Railway Spikes.** The experiments made by Herr Funk on the holding power of railway spikes constitute, as we remarked, one of the most important investigations of the kind ever carried out, the experiments being directed, not merely to ascertaining the power of the spikes to resist a force tending to draw them straight out of the timber, but also to determining their resistance to lateral displacement. The effect of modifications in the forms of the spikes, and variations in the nature of the timber into which they were driven were also taken into consideration.

The resisting power of railway spikes depends chiefly—

1. Upon the kind of timber of which the sleeper is formed, and the condition of the latter.
2. Upon the shape and dimensions of the spikes.
3. Upon the mode of driving them into the sleepers.

The following results are derived from the above investigations, and from former experience gained in the construction and maintenance of permanent way-structures:—

1. Sleepers made of oak are preferable to those made of fir and deal, not only on account of their greater durability, but also on account of the greater resisting power which they give to the spikes. Although experience has not yet sufficiently proved the proportionate durability of prepared oak,

fir, and pine sleepers, it is, nevertheless, advisable to use oak sleepers, even in cases where the prices for the oak are  $1\frac{1}{2}$  or  $1\frac{3}{4}$  times as high as those for the softer kinds of wood.

2. Joint sleepers, where a great resisting power of the spikes is especially necessary, ought to be made of oak, even in those cases where that timber costs about 2 or  $2\frac{1}{4}$  times as much as fir or pine. If the difference of the price, however, is still greater, the joint sleepers of fir ought to be made larger, in order to enable a greater resisting power to be obtained for the spikes by giving the latter additional length.

3. If the intermediate sleepers are made of fir, one or two of these sleepers—according to whether 15 or 21 ft. rails are used—ought to have two spikes on the outside of the rail base, or small bedplates, 3 or 4 inches wide, should be adopted, in order to increase the resisting power of the spikes against lateral pressure, and especially to bring the inside spike also into action. The number of these outside spikes or bedplates ought to be increased in curves of small radii on the outer line of rails, or ought to be provided with a bedplate with two holes.

4. The impregnation of the sleepers with chloride of zinc does not influence the resisting power of the spikes, but this power seems to be a little less for newly prepared sleepers which are still completely saturated with water.

5. The bellied spikes possess the smallest resisting power, this power being only 0.7 or 0.9 of that for prismatic spikes of the same weight.

6. No favorable result is obtained by twisting the spikes or by jaggng their edges.

7. The resisting power of double pyramidal spikes of short length is for deal about  $\frac{1}{4}$  greater than that of straight prismatic spikes of the same weight; this advantage does not exist, however, in the case of spikes of greater length, nor when the spikes are driven into oak.

8. The simple pyramidal spikes and the prismatic spikes, if both are driven equally deep into the wood, offer the same resisting power against being drawn out of the timber, whilst, if the same volume of both is driven into the wood, the holding power of the former is for oak and for long spikes about  $\frac{1}{10}$ , and for deal and for shorter spikes about  $\frac{1}{4}$  greater than the resisting power of prismatic spikes. But with respect to the resisting power against lateral displacements within the limits important for permanent way-structure

tures, the prismatic spikes are in a similar proportion stronger than pyramidal spikes.

9. The pyramidal spikes costing about 20 per cent. more than prismatic spikes of the same weight, the advantage of the smaller volume of iron driven into the wood for the necessary depth of 5 or 6 inches (found by experience to be a sufficient depth for the spiking of rails), is completely compensated; the prismatic spikes are, therefore, preferable to pyramidal spikes, as the former, besides their greater resisting power against lateral pressure, have not the great disadvantage of the latter spikes of becoming, when once loosened, soon entirely powerless.

763. **Baron von Weber's Experiments on the Resisting Power of Spikes.** The experiments above described being of a very satisfactory kind, Baron von Weber's researches were conducted so as to deal with questions to which Herr Funk's experiments did not relate, and they were especially carried out for the purpose of ascertaining the influence of the pressure of the wheels against the rails upon the resisting power of the spikes.

The average results deduced by Baron von Weber, from the experiments we have recorded, are that, in the case of the fir sleepers, a force of about 1,850 lbs., and in the case of oak sleepers, a force of about 3,000 lbs. was required for drawing the spikes. As the latter had 73 square centimetres, or 11.3 square inches, of surface in contact with the timbers, the forces required for drawing the spikes were :

	Pounds per square inch of surface.
In fir sleepers.....	163.2
In oak sleepers.....	269.6

These values for the holding power are much less than those found by von Kaven and Funk, and there is also somewhat less difference between the respective holding powers in fir and oak than was shown by the researches of those experimenters. Baron von Weber, however, considers—and we agree with him—that the difference between von Kaven and Funk's results and his own are fully accounted for by the fact that in the latter experiments the spikes were not merely subjected to a pull in the direction of their axes, but were exposed also to lateral pressure, the pull being exerted on the underside of the nose or head. Baron von Weber considers also that, from the fibres of oak having less flexibility than those of fir, this

lateral pressure would produce greater loosening of the spikes in the former than in the latter timber, and hence there would be less difference in the holding power of the spikes in the two kinds of sleepers, than was shown by the researches of former experimenters, who applied a direct pull to the spikes.

This fact shows, as is remarked by Baron von Weber, that results of direct practical value can only be obtained by experiments carried out under the circumstances which exist in actual practice, and he considers, for this reason, that the values for the holding power of spikes deduced from his researches are more reliable for practical use than those obtained from previous experiments.

**764. Experiments on the effects of Bedplates.** After the preceding experiments had been carried out, it became desirable, in order to complete the inquiries relating to the influence of the means usually adopted for effecting the connection between the rails and sleepers, that some experiments should be made to ascertain the effect of interposing rolled iron bedplates between the sleepers and rails. Such bedplates are generally supposed to serve three purposes. Thus, first, they render the spikes driven into the sleepers on both sides of the rail dependent on each other, it being impossible for one to be displaced without the other being displaced also; and thus it might be expected *a priori* that the resistance of the spikes to lateral displacement would be doubled. Second, the plates prevent the impression of the edge of the rail into the sleeper, an action which is often the reason for the rail canting; and, third, they practically increase the bearing surface of the base of the rail upon the sleeper.

In this series of trials, two pieces of rails were fastened, at the usual gauge apart, upon three fir sleepers, and between the rails and the central sleepers were placed bedplates of the

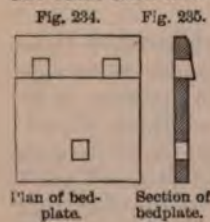

shape shown in Figs. 234 and 235. The spikes fitted the holes in the plate well, and at the same time pressed firmly against the bases of the rails. The plates were arranged in such a manner that the side of one hole was placed towards the inside of the rails, and the press acted against the heads of the rails directly above the plates.

The effect of the plates in the above experiment was very clear, and they evidently increased the resistance of the spikes to lateral displacement until the latter has been drawn out of the timber. In fact, the pressure required to loosen the

structure was more than double that necessary in the case of the structure without plates.

In this case, the rails were fixed upon two sleepers, bedplates being interposed between the former and the latter, and the press being placed so as to act upon the heads of the rails midway between the two sleepers.

The prevention of the lateral displacement of the rails resulting from the use of plates, was in the above instance the cause of a greater stability of the heads of the rails, but it at the same time had the effect of causing the more rigid structure to become loosened with a less widening of the gauge and a less pressure than was the case with the more elastic structure without plates. But the deferred loosening of the structure without plates was practically of no value, for before the loosening took place the gauge had been widened to such an extent that the line would have been unfit for use.

In these trials the rails were fastened upon four sleepers with bedplates, and the press acted against the heads of the rails in the middle between the central sleepers.

The loosening of the structure with plates took place at a smaller widening of the gauge, but at a much greater pressure than that of the structure without plates; and the resistance of the structure was in fact increased by the use of the bedplates more than 60 per cent.

In this series the rails were fastened down to five sleepers, bedplates being interposed, but two arrangements of the plates were tested. In the first case, all the bedplates were arranged in the same manner as in the previous experiments, that is, with the side traversed by one spike placed inside; but in the second case, the plates on the three central sleepers were turned so that the side having two spikes was next the centre of the line. Thus six extra spikes were made to act against the canting of the rails, whilst the total number of spikes securing the rails to the sleepers remained the same. The second arrangement was tested for the purpose of ascertaining the most advantageous method of placing the plates to secure stability of the structure.

The above experiments showed that the stability of the structure was practically the same for both positions of the plates, up to a pressure of 80 centners (= 9,075 lbs.). The spikes in the normal arrangements then became loose, while the other arrangement with two spikes inside the rails on each of the three central sleepers allowed a further widening of the gauge up to 38 millimetres (= 1.496 in.) before the resisting power of the fastening ceased. The second arrangement of

the plates thus offered a greater resistance to the destruction of the structure than that in which single spikes were placed inside the rails.

765. The general deductions drawn by Baron von Weber from all the experiments relating to question (g), namely, *What force is required to draw the spikes out of the sleepers?* are as follows:—

1. That the force, in pounds, required to draw out of timber rail-spikes of the usual form—that is to say, square prismatic spikes with chisel points—is to be found, if the strain acts directly in the direction of the axis of the spike, by multiplying the area of the surface of the spike in contact with the timber by the following numbers:—

For fir, 300 lbs. }	} per square inch of surface of the driven portion of
“ oak, 600 “ }	
“ fir, 47 “ }	} per square centimetre of surface of the driven portion
“ oak, 94 “ }	

If, however, the force acts laterally as well as in the direction of the axis, as is generally the case in practice, the multipliers become as follows:—

For fir, 150 lbs. }	} per square inch of surface of the driven portion of the
“ oak, 270 “ }	
“ fir, 25 “ }	} per square centimetre of surface of the driven portion
“ oak, 42 “ }	

2. That spikes driven into a sleeper for the second time after the holes in the timber have been filled up, offer at first greater resistance than spikes driven into new sleepers.

3. That but very small forces are required to produce a widening of the gauge to the extent of 6 or 10 millimetres (0.236 in. or 0.394 in.) as such amounts of widening are within the limits of elasticity of the structure, and require no loosening of the fastenings.

4. That a lateral pressure of 80 centners (= 9,075 lbs.) at the most, acting against one point of the head of the rails, is sufficient to produce either a canting or lateral displacement of the rails to such an extent that the structure at this point is completely and permanently loosened.

5. That the force required for the further spreading and final destruction of the structure is much less than that necessary for the first loosening, the former being seldom more than 75 per cent. of the latter.

6. That the resistance of the structure to a pressure acting against one point of the head of a rail does not increase in

direct proportion to the number of sleepers to which the rail is fastened, but that the elasticity of the rail and consequent torsion permits the fastenings upon the several sleepers to be loosened successively. The resistance of the rails to torsional strains may, however, enable the fastenings at any one point to receive such support from the adjoining fastenings that the resistance to canting at that point may be doubled.

7. That if the elasticity of the rails is very great, a widening of the gauge to the extent of 25 millimetres (=0.984 in.) may be produced without remaining permanent or without showing signs of having occurred after the pressure has been removed. This is more likely to happen if the widening of the gauge is produced by the canting of the rails than if it is due to their lateral displacement on the sleepers; in the latter case the displacement of the fastenings would be visible, whilst in the former a slight raising of the spikes in the direction of their axis would only be observed under very favorable circumstances.

8. That in the case of structures having the joints of the two lines of rails arranged opposite each other or the same sleeper, the points on which the joints occur offer considerably less resistance to a widening of the gauge than is the case when the rails are disposed so as to break joint, the proportionate resisting powers in the two cases being about as 7 to 10. Thus a permanent way, having the joints of the two lines of rails opposite each other, has as many points as there are joints, at which the lateral stability or power to resist widening of the gauge, is but  $\frac{7}{10}$  of that at the joints of the structure having the rails disposed so as to break joint. This is of importance with respect to accidents originating from the widening of the gauge.

9. That the application of bedplates between the rails and sleepers increases—under otherwise equal circumstances—the power of resistance of the structure to lateral displacement of the rails; but that the loosening of the fastenings takes place with a smaller displacing movement.

We now come to the experiments relating to question (*h*), namely: "What force is required to overcome the total resistance due to the combination of the holding power of the spikes in the sleepers and the friction between the rails and wheels?"

The trials just recorded are, as Baron von Weber justly observes, very instructive, for they prove that the friction between the rails and the sleepers, *plus* the resistance of the outside spikes, is sufficient to keep the rails in their places, even



when the pressure against the heads is such as to cause the canting of the rails to an extent sufficient to render the line unfit for traffic. The experiments also show that the inside spikes afford proportionately little resistance, and that they represent the weakest points of the structure. In fact, the fastened and loaded rails showed, under the influence of the same displacing power, displacements which were certainly not less than those obtained in the case of the structure in which the inside spikes had been loosened.

Nothing now remained connected with this part of Baron von Weber's investigations but to collect facts showing the influence of the state of the surface of the rails upon the stability of the structure.

766. The deductions made by him from the experiments relating to the question (h), "*What force is required to overcome the total resistance due to the combination of the holding power of the spikes in the sleepers and the friction between the rails and wheels?*" are as follows:—

1. That the resisting power of the rails to lateral forces is considerably increased through the friction between the wheels and rails, this friction causing the axle to form a kind of tie between the two rails.

2. That if the load upon the rail is more than 9,075 lbs. per wheel or vehicle, the resisting power of the rails to canting due to the friction just mentioned is greater than that due to the spiking of the rails in the ordinary way to fir sleepers.

3. That the resistance of the rails to lateral displacement on the sleepers is increased by the load on the rails in the proportion of 0.33 of that load; whence, in the case of rails carrying the load of 6,806 lbs. per wheel, the resistance of the rails to lateral displacement on the sleepers due to the load, is greater than that due to the resisting power of the spikes.

4. That if the load be more than 9,075 lbs. per wheel, the frictional resistances cause the rails to be supported at top and bottom against both canting and lateral displacement, and the support thus afforded is more effective than that due to the ordinary spiking.

5. That the forces tending to produce canting and lateral displacement due to the horizontal oscillations of the rolling stock, can only be resisted (at least in most cases) by the combined action of the spikes, the friction between the wheels and rails, and the friction between the rails and sleepers.

6. That if, therefore, the load upon one point of the structure be partially or entirely removed by the undue vertica:

oscillation of a vehicle, whilst, at the same time, a lateral oscillation of the vehicle takes place, the stability of the structure against the pressure due to this lateral oscillation depends solely upon the insufficient resisting power of the spikes, and the lateral distortion and displacement are the unavoidable consequences. This last deduction is, as Baron von Weber justly considers, one of very great importance, and, in fact, the experimental researches upon which it is founded may be said to prove the cause which leads to the serpentine displacements of the rails but too frequently met with on straight portions of a line of railway, particularly if the line is one of light construction, or is traversed by locomotives having considerable overhang at the leading and trailing ends. If such a portion of a line contains a sleeper badly bedded, which sinks uniformly throughout its entire length under the influence of a passing load, the vehicle passing over it will make but a heavy vertical oscillation, having no influence upon the lateral resisting power of the structure. But if the sleeper sinks under one rail more deeply than under the other, the oscillation of the vehicle will be at once horizontal and vertical, and the load will be removed more or less, first from the trailing and then from the leading axle, thus causing the lateral pressure due to the horizontal oscillations to be exerted through the tires of the wheels with full power against the rails.

In such a case it is almost unavoidable that the point of the unloaded, or partially unloaded, structure should be displaced laterally; but this displacement having once occurred, the oscillations of the passing vehicles become so considerable, both in a horizontal and vertical direction, that the displacement of the rail is soon repeated, and only favorable circumstances, such as coincidence of the oscillations, can then produce a uniform motion of the vehicles. The displacements just referred to are considered by Baron von Weber to be most dangerous, both for the stability of the structure, and the passage of the trains, because their original causes can only be discovered with great difficulty, even when the permanent way is most carefully maintained.

767. Notwithstanding the great value of the results obtained from the experiments we have already described, it is undeniable that some of the main questions relating to the stability of permanent way-structures can only be finally answered by ascertaining the amount of the momentary deflections and displacements of the rails which actually occur when a line is subjected to the action of passing trains, but which

disappear either entirely, or almost entirely, after the action which causes them ceases, and which are thus, under ordinary circumstances, likely to escape observation.

The momentary deflections and displacements just referred to may be divided into two classes, namely, those which apparently disappear on the removal of the load, and those which disappear absolutely. To the first class belong those deflections and displacements which, although causing a greater or less loosening of the structure, are yet within the limits of elasticity of the rails, so that the latter, after the passage of the train, return to their normal positions, and there are only left to make the movements which have taken place, the small lateral displacements of the spikes, or small impressions of the sleepers by the bases of the rails. Such marks of displacements are likely to escape any but very careful inspection; yet, taken altogether, they may allow to the rails an amount of play or liberty to cant which may produce dangerous results. The second class of momentary displacements, on the other hand, consists of those which take place within the limits of elasticity of the permanent way-structure as a whole, all the parts returning to their normal positions on the removal of the cause of the disturbance. Such momentary alterations as these in the positions of the rails occur less frequently than those of the former class, but they may nevertheless become dangerous under certain circumstances which will be spoken of hereafter.

We now come to the deductions drawn by Baron von Weber, from the results of the various series of experiments recorded by us in the preceding articles of the present series. It is the opinion of the Baron that the tendency of advanced railway practice is to abandon the ordinary system of iron or steel rails fixed on wooden sleepers for the use of permanent way-structures formed of iron alone, and he considers that ultimately lines of rails will be constructed as continuous girders, strong enough to resist all the actions of the rolling stock, and resisting directly upon properly prepared ground, without the intervention of intermediate members or perishable materials. "Looking back," he says, "upon the experimental researches, we are struck by an extraordinary fact, the remarkable character of which is enhanced by the circumstance that it has been little known and still less taken into consideration. This fact is that heavy trains and powerful engines have already ran longer than the age of the present generation upon lines or structures, the flexibility of which is so great that every wheel leaves its impression, and every os-

cillation produces a displacement; and of which the stability—as far as it depends upon the resisting power of its mechanical parts—is so small in proportion to the disturbing influences brought to bear upon it, that almost any one of these influences would destroy the structure if it were not that the very load itself increased the stability through the agency of the friction between the wheels and the rails. It would be quite unworthy of engineers and engineering science to reply that as the traffic has for a long period been satisfactorily carried on lines possessing such flexibility, that, therefore, it is of no importance whence the stability comes, so long as it is there when required. We might as well state that the neighborhood of a certain powder-mill is free from danger, because explosions have occurred but rarely during the last five-and-thirty years.”

**763. Deductions of Baron von Weber from tabulated results.** Baron von Weber makes a series of deductions which are worthy of the careful attention of both locomotive superintendents and engineers in charge of permanent way. These deductions are in substance as follows:—

1. That, as is well known, six-wheeled locomotives, when running, oscillate round their central axle, a dipping or plunging motion taking place towards the leading and trailing end alternately. Thus the loads upon the leading and trailing springs vary according to the oscillations, and consequently the pressures exerted by the leading and trailing wheels upon the rails vary also.

2. That in the case of engines on which the experiments were made the greatest load imposed in this manner upon the springs exceeded the normal load by 103 per cent. (the increase of load being from 70 to 160 centners per wheel) in the case of the leading springs, and by 74 per cent. (the increase being from 115 to 200 centners per wheel) in the case of the trailing springs.

3. That the maximum loads just mentioned are much greater than that laid down by the rules acknowledged by German railways, namely, a maximum of 130 centners per wheel. Thus in determining the strength of permanent way-structures this great increase of the pressure sometimes exercised upon the rails should be taken into consideration.

4. That the load upon the springs is sometimes reduced during the running of the engine to about 7 per cent. of the normal load (the reduction being from 79 to 5 centners) in the case of the leading springs, and to 26 per cent. of the normal load (from 114 to 30 centners) in the case of the

trailing springs. The decrease, or even sometimes the almost entire removal of the load from the leading springs is surprising. The experiments, of which an account has just been given, prove that the permanent way is momentarily subjected to far greater loads than it is ordinarily supposed to carry, and further that it is sometimes almost entirely relieved of its load as above stated. It appears also certain that there exist horizontal oscillations of the vehicles produced at first by partially vertical oscillations, and there thus exists the greatest probability of the coincidence of such a relief from load as has just been mentioned, with a horizontal oscillation towards the rail from which the load has just been removed, the result being a displacement of the permanent way, as, under the circumstances supposed, the opposition offered by the latter is but that due to its mechanical structure. The experiments on the stability of permanent way already described, together with the investigations of the variations of load on the wheels of the engines, explain in a satisfactory manner the causes of many cases of widening of the gauge and displacement of the structure previously considered inexplicable.

5. The difference between the maximum and minimum loads resting at different times on the same spring varies by more than double the normal load in the case of the leading wheels; but seldom by more than 40 per cent. of that load in the case of the trailing wheels, a circumstance which indicates that the real centre of oscillation of the masses forming the engine is situated between the driving and trailing axle, and not over the former.

6. That the extreme amounts of variation in the loads on the leading and trailing springs were found to occur in an engine the construction of which would have least justified the expectation of their taking place. This engine was the "Prometheus," in which the wheel base differed very little from the length of the boiler, and in which about 60 per cent. of the load was removed from the leading wheel, while that on the trailing wheels was reduced to 77 per cent. of the normal load. This fact points strongly to the danger often attendant upon placing a great load upon the driving axle, if the latter is situated under the centre of the engine.

769. Sleepers. The preservation of sleepers by chemical processes is always the subject of experiment on one or another of our railways. The practice, however, is not general in this country, because the mashing of the rail into the sleeper usually destroys it in advance of decay. In England, the

bearings of the chains used with the double-headed rail on every sleeper are so extended, that the mechanical injury of the wood is quite small. Prevention against decay—usually immersion in coal-tar—is therefore generally practised. The insufficient bearing offered by sleepers to the rails is thus, directly and indirectly, the cause of their rapid destruction. It is stated that placing the sleepers closer than, say two feet apart between centres, would prevent the convenient tamping of the ballast. It is objected to the longitudinal sleeper, that the rail lying parallel with the fibre of the wood, mashes into it more easily than into the cross-sleeper. These objections to insufficient bearing are not inherent in either system, but arise from improper construction. Thoroughly good ballast would not require continual tamping. It is even proposed by some of our most experienced engineers to cover the ballast with a coating of coal-tar and gravel, to absolutely exclude water, and thus prevent not only decay, but washing, freezing, heaving, settling—all destroying elements but vibration and wear. In this case the timber bearings under the rails should be almost continuous, to prevent wear both on the ballast and on the rail. The mashing of rails into timbers, either longitudinals or cross-sleepers, is largely due to the want of stiffness in the rails themselves. The low  $\Omega$  rails on the Great Western of England are the most notable examples of this kind of failure. If the iron wasted in the thick stem and pear-head of our worst shaped rails were put into the height of stem, their resistance to deflection would be doubled, this resistance being as the cube of the depth.

There is a growing conviction among engineers, that the longitudinal system will become standard. It offers twice to three times as much bearing for the rail as the cross-sleeper system. The whole strength of a longitudinal is added to the strength of the rail, considered as a beam to carry the load. The strength of the cross-sleeper in this direction is wholly wasted. The longitudinal is almost certain to prevent the displacement of a broken rail. This system has never been tried on a large scale, with a high, stiff rail. It requires better ballast, and more thorough adjustment than the other system. Independent points of support, like the isolated ends of cross-sleepers, that can be blocked up or let down at pleasure, without reference to the rest of the superstructure, are the indispensable accompaniment of bad ballasting and imperfect drainage. But they are unsuited to any system of homogeneous, continuous, and permanent way.

Iron sleepers are coming into use in countries where tim-

ber is very costly and unsuitable, and are the subjects of various experiments in England.

The great defect of all imperishable sleepers, whether stone or iron, has been want of elasticity. An anvil under a rail, and especially under a joint, is as bad if not worse than an insufficient support.

**770. Rail-Joints.** The selection of joint fastenings for the ends of rails is somewhat dependent upon the weight of rail required, and hence upon the traffic. After twenty years of competitive trial with every variety of fastening, the simple "fish-joint"—an iron splice on each side of the rail—has become standard in Europe, and is gaining ground here. It is the lightest and strongest fastening that can be applied, when rails are high, and properly shaped to receive it. The old difficulty of nuts jarring loose has been overcome by the use of elastic washers. Fishing a pear-headed rail, three or three and a half inches high, would be perfectly useless. For light rails, and for steel rails (to save weakening them by punching), and as an auxiliary to the fish-joint, the new Reeves' fastening—a light clamp upon the contiguous flanges of two rails—is coming largely into use. The mere chair or seating for the ends of rails is no longer considered safe nor economical for lines of heavy traffic. Although there is room for farther experiment, it cannot be said that the demand for a good rail-joint has not been met.

**771. Steel Rails—The Results.** Bessemer steel rails have been in regular and extensive use abroad over ten years. For several years large trial-lots have been laid on various American roads having heavy traffic.

**772. The Wear of Steel Rails.** As no steel rails are reported to have worn out on our roads, the comparative durability of steel and iron cannot be absolutely determined.

A great number of instances of the comparative wear of steel were cited. In one case twenty-three iron rails had been worn out, where a steel rail, laid end to end with the iron, was not yet worn down. In other cases the wear was seven to one. It is conceded that any steel rail will outlast six iron rails. In fact, the remarkable wearing qualities of steel rails have never been doubted or questioned.

**773. Breakage of Steel Rails.** Some steel rails of English, French, and American manufacture have broken in service. In several cases the cause has been ascertained by the direct analysis of the broken rail. The cause was phosphorus. In some other cases, where analyses were not made, the *general* character of the iron used has been ascer

tained, and the trouble has been *inferred* to be phosphorus, or, in some cases, an excess of silicon. It is well known to steel makers that a very minute proportion of phosphorus (above 0.2 per cent.) will make Bessemer steel brittle. In other cases rails have broken at the mark of the "gag," or instrument for straightening the rail cold. The rails had not been properly hot-straightened, or were finished at too low a heat. More rails have broken through punched fish-bolt holes, and at punched nicks in the flange, than at any other places. Experiments prove that punching a hole in a steel rail which is sufficiently hard to wear well, weakens it.

In the absence of further official information, it is fair to assume that the breakage of steel rails is only a small percentage of the breakage of iron rails. Indeed, the latter is of daily occurrence, and is rarely considered by the public, except when lives are lost, and not always by railway managers when they make contracts.

**774. Tests and Improvements.** The punching of steel rails has been abandoned. Several kinds of power and hand drilling machines have been introduced, that do the work rapidly and well. The loss from the neutral axis of a rail, of the little material necessary to let a bolt through, cannot sensibly weaken it. To prevent the rails from creeping, the engineer of the Pennsylvania railway pins them to several sleepers by means of  $\frac{1}{4}$  inch holes drilled in the flange. There are also other and better devices for preventing end movement, which do not weaken the rail at all. The grand advantage of steel, for service under concussion and wear, is its homogeneity. Having been cast from a liquid state, it is sound and uniform, and free from the laminations and layers of cinder and numerous welds which characterize wrought iron, especially the low grades of wrought iron usually put into rails.

**775. Improved Traction upon Steel Rails.** It has been too much the practice of railway managers to consider only the increased durability of steel. A less striking, but perhaps equally important advantage is, that it has double the strength and more than double the stiffness of iron.

The great and constant resistance to traction, and the wear and tear of track, wheels, and running gear, due to the friction of rails between the sleepers and the perpetual series of resulting concussions, may be much reduced, or practically avoided, by the use of rails of twice the ordinary stiffness; in such a case, however, reasonably good ballasting and sleepers would be essential. When a whole series of sleep-



ers sinks bodily into the mud, the consideration of deflection between the sleepers is a premature refinement. If the weight of steel rails is decreased in proportion to their strength, these advantages of cheaper traction and maintenance will not, of course, be realized. The best practice, here and abroad, is to use the same weight for steel as had been formerly employed for iron.

**776. Steel-headed Rails.** Many attempts have been made in England, on the Continent, and in this country, to produce a good steel-headed rail, and not without success. Puddled steel heads have all the structural defects of wrought iron, as they are not formed from a cast, and hence homogeneous mass, but are made by the wrought-iron process, and are, in fact, a "high" steely wrought iron. They are, however, a great improvement upon ordinary iron, although probably little cheaper than cast-steel heads. Rolling a plain cast-steel slab upon an iron pile has not proved successful. The weld cannot be perfected on so large a scale, and the steel peels off under the action of car wheels. Forming the steel slab with grooves, into which the iron would dovetail when the pile was rolled into a rail, has been quite successful.

## CHAPTER VIII.

## CANALS.

777. *Canals* are artificial channels for water, applied to the purpose of inland navigation; for the supply of cities with water; for draining; for irrigation, &c., &c.

778. *Navigable* canals are divided into two classes: 1st. Canals which are on the same level throughout their entire length, as those which are found in low level countries. 2d. Canals which connect two points of different levels, which lie either in the same valley, or on opposite sides of a dividing ridge. This class is found in broken countries, in which it is necessary to divide the entire length of the canal into several level portions, the communication between which is effected by some artificial means. When the points to be connected lie on opposite sides of a dividing ridge, the highest reach, which crosses the ridge, is termed the *summit level*.

779. 1st CLASS. The surveying and laying out a canal in a level country, are operations of such extreme simplicity as to require no particular notice in this place.

The cross section of this class (Fig. 236) presents usually a



Fig. 236—Cross section of a canal in level cutting.

- A, water-way.
- B, tow-paths.
- C, berms.
- D, side-drains.
- E, puddling of clay or sand.

*water-way*, or channel of a trapezoidal form, with an embankment on each side, raised above the general level of the country, and formed of the excavation for the water-way. The level, or surface of the water, is usually above the natural surface, sufficient thickness being given to the embankments to prevent the filtration of the water through them, and to resist its pressure. This arrangement has in its favor the advantage of economy in the labor of excavating and embanking,

since the cross section of the cutting may be so calculated as to furnish the necessary earth for the embankment; but it exposes the surrounding country to injury, from accidents happening to the embankments.

The relative dimensions of the parts of the cross section may be generally stated as follows; subject to such modifications as each particular case may seem to demand.

The width of the water-way, at bottom, should be at least twice the width of the boats used in navigating the canal; so that two boats, in passing each other, may, by sheering towards the sides, avoid being brought into contact.

The depth of the water-way should be at least eighteen inches greater than the draft of the boat, to facilitate the motion of the boat, particularly if there are water-plants growing on the bottom.

The side slopes of the water-way, in compact soils, should receive a base at least once-and-a-half the altitude, and proportionally more as the soil is less compact.

The thickness of the embankments, at top, is seldom regulated by the pressure of the water against them, as this, in most cases, is inconsiderable, but to prevent filtration, which, were it to take place, would soon cause their destruction. A thickness from four to six feet, at top, with the additional thickness given by the side slopes at the water surface, will, in most cases, be amply sufficient to prevent filtrations. A pathway for the horses attached to the boats, termed a *tow-path*, which is made on one of the embankments, and a foot-path on the other, which should be wide enough to serve as an occasional tow-path, give a superabundance of strength to the embankments.

The tow-path should be from ten to twelve feet wide, to allow the horses to pass each other with ease; and the foot-path at least six feet wide. The height of the surfaces of these paths, above the water surface, should not be less than two feet, to avoid the wash of the ripple; nor greater than four feet and a half, for the facility of the draft of the horses in towing. The surface of the tow-path should incline slightly outward, both to convey off the surface water in wet weather, and to give a firmer footing to the horses, which naturally draw from the canal.

The side slopes of the embankment vary with the character of the soil: towards the water-way they should seldom be less than two base to one perpendicular; from it, they may, if it be thought necessary, be less. The interior slope is usually not carried up unbroken from the bottom to the top; but a hori-

zontal space, termed a *bench*, or *berm*, about one or two feet wide, is left, about one foot above the water surface, between the side slope of the water-way and the foot of the embankment above the berm. This space serves to protect the upper part of the interior side slope, and is, in some cases, planted with such shrubbery as grows most luxuriantly in aquatic localities, to protect more efficaciously the banks by the support which its roots give to the soil. The side slopes are better protected by a revêtement of dry stone. Aquatic plants of the bulrush kind have been used, with success, for the same purpose; being planted on the bottom, at the foot of the side slope, they serve to break the ripple, and preserve the slopes from its effects.

The earth of which the embankments are formed should be of a good binding character, and perfectly free from vegetable mould, and all vegetable matter, as the roots of plants, &c. In forming the embankments, the vegetable mould should be carefully removed from the surface on which they are to rest; and they should be carried up in uniform layers, from nine to twelve inches thick, and be well rammed. If the character of the earth, of which the embankments are formed, is such as not to present entire security against filtration, a puddling of clay, or fine sand, two or three feet thick, may be laid in the interior of the mass, penetrating a foot below the natural surface. Sand is useful in preventing filtration caused by the holes made in the embankments near the water surface by insects, moles, rats, &c.

Side drains must be made, on each side, a foot or two from the embankments, to prevent the surface water of the natural surface from injuring the embankments.

**780. 2d CLASS.** This class will admit of two subdivisions: 1st. Canals which lie throughout in the same valley; 2d. Canals with a summit level.

**Location.** In laying out canals, belonging to the first subdivision, the engineer must be guided in his choice by the relative expense of construction on the two sides of the valley; which will depend on the quantity of cutting and filling, the masonry for the culverts, &c., and the nature of the soil as adapted to holding water. All other things being equal, the side on which the fewest secondary water-courses are found will, generally speaking, offer the greatest advantage as to expense, but it may happen that the secondary water-courses will be required to feed the canal with water, in which case it will be necessary to lay out the line on the side where they are found most convenient, and in most abundance.

**781. Cross section.** The side formations of excavations and embankments require peculiar care, particularly the latter, as any crevices, when they are first formed, or which may take place by settling, might prove destructive to the work. In most cases, a stratum of good binding earth, lining the water-way throughout to the thickness of about four feet, if compactly rammed, will be found to offer sufficient security, if the substructure is of a firm character, and not liable to settle. Fine sand has been applied with success to stop the leakage in canals. The sand for this purpose is sprinkled, in small quantities at a time, over the surface of the water, and gradually fills up the outlets in the bottom and sides of the canal. But neither this nor puddling has been found to answer in all cases, particularly where the substructure is formed of fragments of rocks offering large crevices to filtrations, or is of a marly nature. In such cases it has been found necessary to line the water-way throughout with stone, laid in hydraulic mortar. A lining of this character (Fig. 237), both

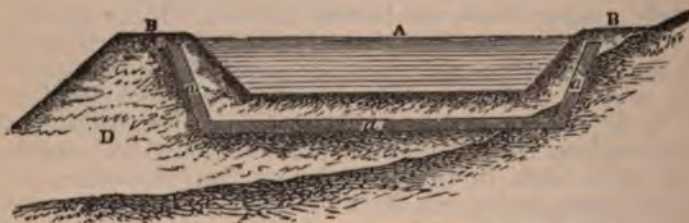

Fig. 237—Cross section of a canal in side cutting lined with masonry  
 A, water-way.  
 B, tow-paths.  
 D, embankment.  
 a, masonry lining.

at the bottom and sides, formed of flat stones, about four inches thick, laid on a bed of hydraulic mortar, one inch thick, and covered by a similar coat of mortar, making the entire thickness of the lining six inches, has been found to answer all the required purposes. This lining should be covered, both at bottom and on the sides, by a layer of good earth, at least three feet thick, to protect it from the shock of the boats striking either of those parts.

The cross section of the canal and its tow-paths in deep cutting (Fig. 238) should be regulated in the same way as in canals of the first class; but when the cuttings are of considerable depth, it has been recommended to reduce both to the dimensions strictly necessary for the passage of a single boat.



Fig. 238.—Cross section of a canal in deep cutting.  
E, side slopes of cutting.

By this reduction there would be some economy in the excavations; but this advantage would, generally, be of too trifling a character to be placed as an offset to the inconveniences resulting to the navigation, particularly where an active trade was to be carried on.

**782. Summit level.** As the water for the supply of the summit level of a canal must be collected from the ground that lies above it, the position selected for the summit level should be at the lowest point practicable of the dividing ridge, between the two branches of the canal. In selecting this point, and the direction of the two branches of the canal, the engineer will be guided by the considerations with regard to the natural features of the surface, which have already been dwelt upon.

**783. Supply of water.** The quantity of water required for canals with a summit level, may be divided into two portions. 1st. That which is required for the summit level, and those levels which draw from it their supply. 2d. That which is wanted for the levels below those, and which is furnished from other sources.

The supply of the first portion, which must be collected at the summit level, may be divided into several elements: 1st. The quantity required to fill the summit level, and the levels which draw their supply from it. 2d. the quantity required to supply losses, arising from accidents; as breaches in the banks, and the emptying of the levels for repairs. 3d. The supplies for losses from surface evaporation, from leakage through the soil, and through the lock gates. 4th. The quantity required for the service of the navigation, arising from the passage of the boats from one level to another. Owing to the want of sufficient data, founded on accurate observations, no precise amount can be assigned to these various elements which will serve the engineer as data for rigorous calculation.

The quantity required, in the first place, to fill the summit level and its dependent levels, will depend on their size, an

element which can be readily calculated; and upon the quantity which would soak into the soil, which is an element of a very indeterminate character, depending on the nature of the soil in the different levels.

The supplies for accidental losses are of a still less determinate character.

To calculate the supply for losses from surface evaporation, correct observations must be made on the yearly amount of evaporation, and the quantity of rain that falls on the surface; as the loss to be supplied will be the difference between these two quantities.

With regard to the leakage through the soil, it will depend on the greater or less capacity which the soil has for holding water. This element varies not only with the nature of the soil, but also with the shorter or longer time that the canal may have been in use; it having been found to decrease with time, and to be, comparatively, but trifling in old canals. In ordinary soils it may be estimated at about two inches in depth every twenty-four hours, for some time after the canal is first opened. The leakage through the gates will depend on the workmanship of these parts. From experiments by Mr. Fisk, on the *Chesapeake and Ohio* canal, the leakage through the locks at the summit level, which are 100 feet long, 15 feet wide, and have a lift of 8 feet, amounts to twelve locks full daily, or about 50 cubic feet per minute. The monthly loss upon the same canal, from evaporation and filtration, is about twice the quantity of water contained in it. From experiments made by Mr. J. B. Jervis, on the *Erie* canal, the total loss, from evaporation, filtration, and leakage through the gates, is about 100 cubic feet per minute, for each mile.

In estimating the quantity of water expended for the service of the navigation, in passing the boats from one level to another, two distinct cases require examination: 1st. Where there is but one lock between two levels, or in other words, when the locks are isolated. 2d. When there are several contiguous locks, or as it is termed, a *flight* of locks between two levels.

784. A *lock* is a small basin just large enough to receive a boat, in which the water is usually confined on the sides by two upright walls of masonry, and at the ends by two gates, which open and shut, both for the purpose of allowing the boat to pass, and to cut off the water of the upper level from the lower, as well as from the lock while the boat is in it. To pass a boat from one level to the other—from the lower to the

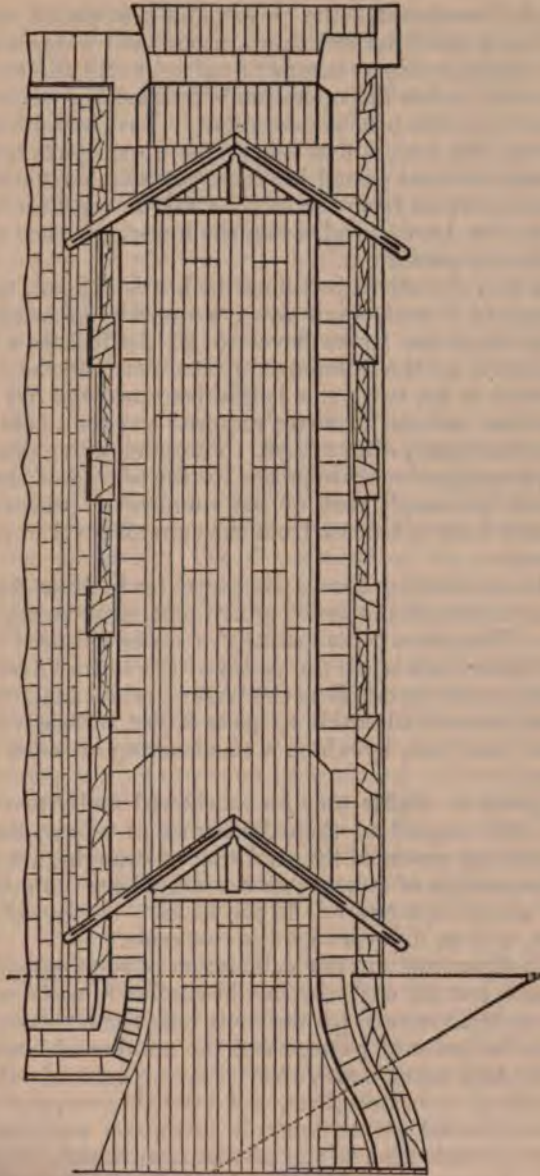

Fig. 238.—Is a plan of the present enlarged form of one-half of a double lock on the Erie Canal.



upper end, for example—the lower gates are opened, and the boat having entered the lock they are shut, and water is drawn from the upper level, by means of valves, to fill the lock and raise the boat; when this operation is finished, the upper gates are opened, and the boat is passed out. To descend from the upper level, the lock is first filled; the upper gates are then opened, and the boat passed in; these gates are next shut, and the water is drawn from the lock by valves, until the boat is lowered to the lower level, when the lower gates are opened and the boat is passed out.

In the two operations just described, it is evident, that for the passage of a boat, up or down, a quantity of water must be drawn from the upper level to fill the lock to a height which is equal to the difference of level between the surface of the water in the two; this height is termed the *lift* of the lock, and the volume of water required to pass a boat up or down is termed the *prism of lift*. The calculation, therefore, for the quantity of water requisite for the service of the navigation, will be simply that of the number of prisms of lift which each boat will draw from the summit level in passing up or down.

785. In calculating the expenditure for locks in flights, a new element, termed the *prism of draught*, must be taken into account. This prism is the quantity of water required to float the boat in the lock when the prism of lift is drawn off; and is evidently equal in depth to the water in the canal, unless it should be deemed advisable to make it just sufficient for the draught of the boat, by which a small saving of water might be effected.

786. Locks in flights may be considered under two points of view, with regard to the expenditure of water; the first, where both the prism of lift, and that of draught, are drawn off for the passage of a boat; or second, where the prisms of draught are always retained in the locks. The expenditure, of course, will be different for the two cases.

Great refinements in the calculation of such cases should not be made, but the engineer should confine himself to making an ample allowance for the most unfavorable cases, both as regards the order of passage and the number of boats.

787. **Feeders and Reservoirs.** Having ascertained, from the preceding considerations, the probable supply which should be collected at the summit level, the engineer will next direct his attention to the sources from which it may be procured. Theoretically considered, all the water that drains from the ground adjacent to the summit level, and above it,

might be collected for its supply; but it is found in practice that channels for the conveyance of water must have certain slopes, and that these slopes, moreover, will regulate the supply furnished in a certain time, all other things being equal. In making, however, the survey of the country, from which the water is to be supplied to the summit level, all the ground above it should be examined, leaving the determination of the slopes for after considerations. The survey for this object consists in making an accurate delineation of all the water-courses above the summit level, and in ascertaining the quantity of water which can be furnished by each in a given time. This survey, as well as the measurement of the quantity of water furnished by each stream, which is termed the *gauging*, should be made in the driest season of the year, in order to ascertain the minimum supply.

788. The usual method of collecting the water of the sources, and conveying it to the summit level, is by feeders and reservoirs. The *feeder* is a canal of a small cross section, which is traced on the surface of the ground with a suitable slope, to convey the water either into the reservoir, or direct to the summit level. The dimensions of the cross section, and the longitudinal slope of the feeder, should bear certain relations to each other, in order that it shall deliver a certain supply in a given time. The smaller the slope given to the feeder, the lower will be the points at which it will intersect the sources of supply, and therefore the greater will be the quantity of water which it will receive. This slope, however, has a practical limit, which is laid down at four inches in 1,000 yards, or nine thousand base to one altitude; and the greatest slope should not exceed that which would give the current a greater mean velocity than thirteen inches per second, in order that the bed of the feeder may not be injured. Feeders are furnished like ordinary canals, with contrivances to let off a part, or the whole, of the water in them, in cases of heavy rains, or for making repairs.

But a small proportion of the water collected by the feeders is delivered at the reservoir; the loss from various causes being much greater in them than in canals. From observations made on some of the feeders of canals in France, which have been in use for a long period, it appears that the feeder of the *Briare* canal delivers only about one-fourth of the water it gathers from its sources of supply; and that the annual loss of the two feeders of the *Languedoc* canal amounts to 100 times the quantity of water which they can contain.

789. A *Reservoir* is a large pond, or body of water, held in

reserve for the necessary supply of the summit level. A reservoir is usually formed by choosing a suitable site in a deep and narrow valley, which lies above the summit level, and erecting a dam of earth, or of masonry, across the outlet of the valley, or at some more suitable point, to confine the water to be collected. The object to be attained, in this case, is to embody the greatest volume of water, and at the same time present the smallest evaporating surface, at the smallest cost for the construction of the dam.

It is generally deemed best to have two reservoirs for the supply, one to contain the greater quantity of water, and the other, which is termed the *distributing* reservoir, to regulate the supply to the summit level. If, however, the summit level is very capacious, it may be used as the distributing reservoir.

The proportion between the quantity of water that falls upon a given surface, and that which can be collected from it for the supply of a reservoir, varies considerably with the latitude, the season of the year, and the natural features of the locality. The drainage is greatest in high latitudes, and in the winter and spring seasons; with respect to the natural features, a wooded surface with narrow and deep valleys will yield a larger amount than an open flat country.

But few observations have been made on this point by engineers. From some by Mr. J. B. Jervis, in reference to the reservoirs for the *Chenango* canal, in the State of New York, it appears that in that locality about two-fifths of the quantity of rain may be collected for the supply of a reservoir. The proportion usually adopted by engineers is one-third.

The loss of water from the reservoir by evaporation, filtration, and other causes, will depend upon the nature of the soil, and the exposure of the water surface. From observations made upon some of the old reservoirs in England and France, it appears that the daily loss averages about half an inch in depth.

790. The dams of reservoirs have been variously constructed: in some cases they have been made entirely of earth (Fig. 240); in others, entirely of masonry; and in others, of earth packed in between several parallel stone walls. It is now thought best to use either earth or masonry alone, according to the circumstances of the case; the comparative expense of the two methods being carefully considered.

Earthen dams should be made with extreme care, of the best binding earth, well freed from everything that might

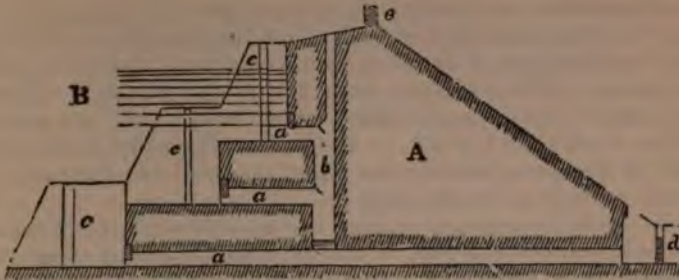

Fig. 240—Represents the section of a dam with three discharging culverts.

A, body of the dam.

B, pond.

a, a, a, culverts, with valves at their inlets, which discharge into the vertical well b.

c, c, c, grooves, in the faces of the side-walls, which form the entrance to the culverts, for stop-plank.

d, stop-plank dam across the outlet of the bottom culvert, to dam back the water into the vertical well.

e, parapet wall on top of the dam.

cause filtrations. A wide trench should be excavated to the firm soil, to receive the base of the dam; and the earth should be carefully spread and rammed in layers not over a foot thick. As a farther precaution, it has in some instances been thought necessary to place a stratum of the best clay puddling in the centre of the dam, reaching from the top to three or four feet below the base. The dam may be from fifteen to twenty feet thick at top. The slope of the dam towards the pond should be from three to six base to one perpendicular; the reverse slope need only be somewhat greater than the natural slope of the earth.

The slope of dams exposed to the water is usually faced with dry stone, to protect the dam from the action of the surface ripple. This kind of facing has not been found to withstand well the action of the water when agitated by high winds. Upon some of the more recent earthen dams erected in France, a facing of stone laid in hydraulic mortar has been substituted for the one of dry stone. The plan adopted for this facing (Fig. 241) consists in placing a series of low walls,



Fig. 241—Represents the method of facing the pond slope of a dam, with low walls placed in offsets.

A, body of the dam.

a, a, a, low walls the faces of which are built in offsets.

b, b, top surface of the offsets between the walls, covered with stone slabs laid in mortar.

c, top of dam faced like the offsets.

d, parapet wall.

in offsets above each other, along the slope of the dam, covering the exposed surface of each offset, between the top of one wall and the foot of the next, with a coating of slab-stone laid in mortar. The walls are from five to six feet high. They are carried up in small offsets upon the face, and are made either vertical, or leaning, on the back. The width of the offsets of the dam, between the top of one wall and the foot of the next, is from two to three feet.

An arched culvert, or a large cast-iron pipe, placed at some suitable point of the base of the dam, which can be closed or opened by a valve, will serve for drawing off the requisite supply of water, and for draining the reservoir in case of repairs.

The culvert should be strongly constructed, and the earth around it be well puddled and rammed, to prevent filtrations. Its size should be sufficient for a man to enter it with ease. The valves may be placed either at the entrance of the culvert, or at some intermediate point between the two ends. Great care should be taken in their arrangement, to secure them from accidents.

When the depth of water in a reservoir is considerable, several culverts should be constructed (Fig. 240), to draw off the water at different levels, as the pressure upon the lower valves in this case would be very great when the reservoir is full. They may be placed at intervals of about twelve feet above each other, and be arranged to discharge their water in a common vertical shaft. In this case it will be well to place a dam of timber at the outlet of the bottom culvert, in order to keep it filled with water, to prevent the injury which the bottom of it might receive from the water discharged from the upper culverts.

The side walls which retain the earth at the entrance to the culverts should be arranged with grooves to receive pieces of scantling laid horizontally between the walls, termed *stop-planks*, to form a temporary dam, and cut off the water of the reservoir, in case of repairs to the culverts, or to the face of the dam.

The valves are small sliding gates, which are raised and lowered by a rack and pinion, or by a screw. The cross section of the culvert is contracted by a partition, either of masonry or timber, at the point where the valve is placed.

791. Dams of masonry are water-tight walls, of suitable forms and dimensions to prevent filtration, and resist the pressure of water in the reservoir. The most suitable cross-section is that of a trapezoid, the face towards the water being

vertical, and the exterior face inclined with a suitable batter to give the wall sufficient stability. The wall should be at least four feet thick at the water line, to prevent filtration, and this thickness may be increased as circumstances may seem to require. Buttresses should be added to the exterior facing, to give the wall greater stability.

792. Suitable dispositions should be made to relieve the dam from all surplus water during wet seasons. For this purpose arrangements should be made for cutting off the sources of supply from the reservoir; and a cut, termed a *waste-weir* (Fig 242), of suitable width and depth, should be made at some point along the top of the dam, and be faced with stone, or wood, to give an outlet to the water over the dam. In high dams the total fall of the water should be divided into several partial falls, by dividing the exterior surface over which the water runs into offsets. To break the shock of the water upon the horizontal surface of the offset, it should be kept covered with a sheet of water retained by a dam placed across its outlet.

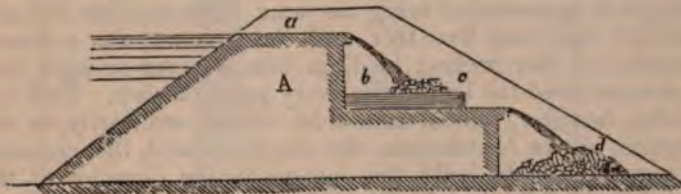

Fig. 242—Represents a section of a waste-weir divided into two falls.  
 A, body of the dam.  
 a, top of the waste-weir.  
 b, pool, formed by a stop-plank dam at c, to break the fall of the water.  
 d, covering of loose stone to break the fall of the water from the pool above.

793. In extensive reservoirs, in which a large surface is exposed to the action of the winds, waves might be forced over the top of the dam, and subject it to danger; in such cases the precaution should be taken of placing a parapet wall towards the outer edge of the top of the dam, and facing the top throughout with flat stones laid in mortar.

794. **Lift of locks.** The engineer is not always left free to select between the two systems—that of isolated locks and locks in flights; for the form of the natural surface of the ground may compel him to adopt a flight of locks at certain points. As to the comparative expense of the two methods, a flight is in most cases cheaper than the same number of single locks, as there are certain parts of the masonry w

can be suppressed. There is also an economy in the suppression of the small gates, which are not needed in flights. It is, however, more difficult to secure the foundations of combined than of single locks from the effects of the water, which forces its way from the upper to the lower level under the locks. Where an active trade is carried on, a double flight is sometimes arranged; one for the ascending, the other for the descending boats. In this case the water which fills one flight may, after the passage of the boat, be partly used for the other, by an arrangement of valves made in the side wall separating the locks.

The lift of locks is a subject of importance, both as regards the consumption of water for the navigation, and the economy of construction. Locks with great lifts, as may be seen from the remarks on the passage of boats, consume more water than those with small lifts. They require also more care in their construction, to preserve them from accidents, owing to the great pressure of water against their sides. The expense of construction is otherwise in their favor; that is, the expense will increase with the total number of locks, the height to be ascended being the same. The smallest lifts are seldom less than five feet, and the greatest, for ordinary canals, not over twelve; medium lifts of seven or eight feet are considered the best under every point of view. This is a point, however, which cannot be settled arbitrarily, as the nature of the foundations, the materials used, the embankments around the locks, the changes in the direction of the canal, caused by varying the lifts, are so many modifying causes, which should be carefully weighed before adopting a definite plan.

The lifts of a flight should be the same throughout; but in isolated locks the lifts may vary according to circumstances. If the supply of water from the summit level requires to be economized with care, the lifts of locks which are furnished from it may be less than those lower down.

**795. Levels.** The position and the dimensions of the levels must be mainly determined by the form of the natural surface. Those points are naturally chosen to pass from one level to another, or as the positions for the locks, where there is an abrupt change in the surface.

A level, by a suitable modification of its cross section, can be made as short as may be deemed desirable; there being but one point to be attended to in this, which is, that a boat passing between the two locks, at the ends of the level, will have time to enter either lock before it can ground, on the

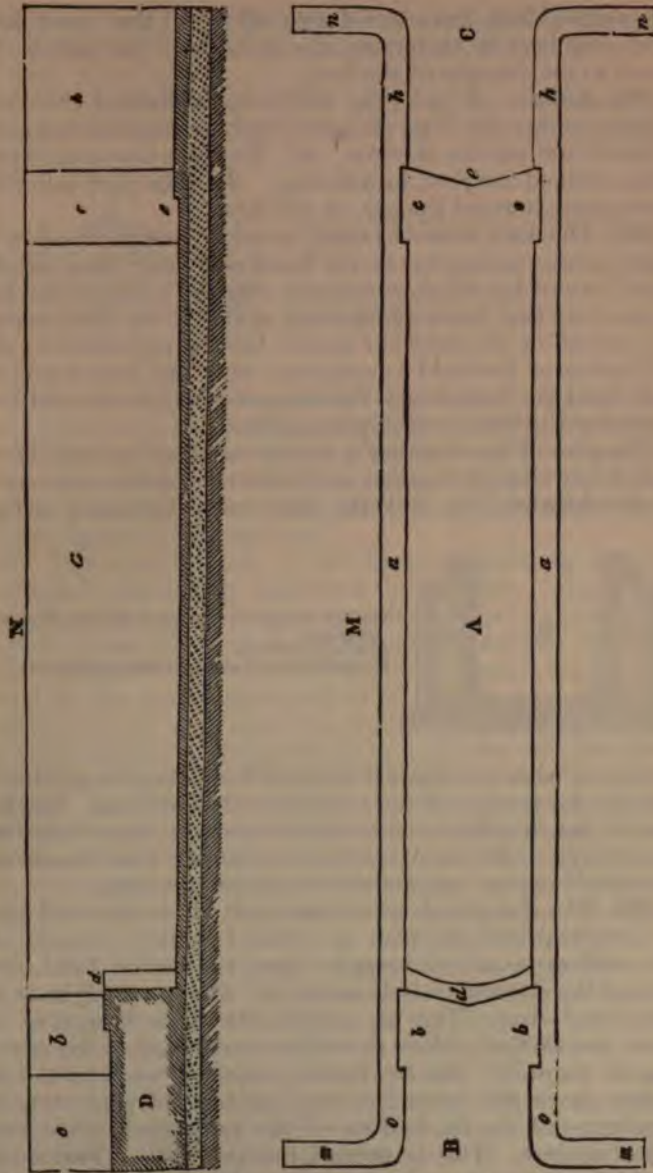

Fig. 243—Represents a plan M, and a section N, through the axis of a single lock laid on a beton foundation.—A, lock-chamber. B, fore-bay. C, tail-bay. *a, a*, chamber-walls. *b, b*, recesses or chambers in the side walls for upper gates. *c, c*, lower-gate chambers. *t*, lift wall and upper mitre sill. *s, s*, lower mitre sill. *h, h*, tall walls. *o, o*, head walls. *m, m*, upper wing, or return walls. *n, n*, lower wing walls. D, body of masonry, under the fore-bay.



supposition that the water drawn off to fill the lower lock, while the boat is traversing the level, will just reduce the depth to the draught of the boat.

796. **Locks.** A lock (Fig. 243) may be divided into three distinct parts: 1st. The part included between the two gates, which is termed the *chamber*. 2d. The part above the upper gates, termed the *fore*, or *head-bay*. 3d. The part below the lower gates, termed the *aft*, or *tail-bay*.

797. The lock chamber must be wide enough to allow an easy ingress and egress to the boats commonly used on the canal; a surplus width of one foot over the width of the boat across the beam is usually deemed sufficient for this purpose. The length of the chamber should be also regulated by that of the boats; it should be such, that when the boat enters the lock from the lower level, the tail-gates may be shut without requiring the boat to unship its rudder.

The plan of the chamber is usually rectangular, as this form is, in every respect, superior to all others. In the cross section of the chamber (Fig. 244) the sides receive generally a slight

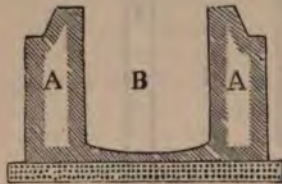

Fig. 244—Represents a section of Fig. 243, through the chamber.  
A, A, chamber walls.  
B, chamber formed with an inverted-arch bottom.

batter; as when so arranged they are found to give greater facility to the passage of the boat than when vertical. The bottom of the chamber is either flat or curved; more water will be required to fill the flat-bottomed chamber than the curved, but it will require less masonry in its construction.

798. The chamber is terminated just within the head gates by a vertical wall, the plan of which is usually curved. As this wall separates the upper from the lower level, it is termed the *lift-wall*; it is usually of the same height as the lift of the levels. The top of the lift-wall is formed of cut stone, the vertical joints of which are normal to the curved face of the wall; this top course projects from six to nine inches above the bottom of the upper level, presenting an angular point, for the bottom of the head-gates, when shut, to rest against. This is termed the *mitre-sill*. Various degrees of opening have been given to the angle between the two branches of the mitre-sill; it is, however, generally so

determined, that the perpendicular of the isosceles triangle, formed by the two branches, shall vary between one-fifth and one-sixth of the base.

As stone mitre-sills are liable to injury from the shock of the gate, they are now usually constructed of timber (Fig. 245),



Fig. 245—Represents a plan of a wooden mitre-sill, and a horizontal section of a lock-gate (Fig. 246) closed.  
*a, a*, mitre-sill framed with the pieces *b* and *c*, and firmly fastened to the side walls *A, A*.  
*d*, section of quoin posts of lock-gate.  
*e*, section of mitre posts.

by framing two strong beams with the proper angle for the gate when closed, and securing them firmly upon the top of the lift-wall. It will be well to place the top of the mitre-sill on the lift-wall a little lower than the bottom of the canal, to preserve it from being struck by the keel of the boat on entering or leaving the lock.

799. The cross section of the chamber walls is usually trapezoidal; the facing receives a slight batter. The chamber walls are exposed to two opposite efforts; the water in the lock on one side, and the embankment against the wall on the other. The pressure of the embankment is the greater as well as the more permanent effort of the two. The dimensions of the wall must be regulated by this pressure. The usual manner of doing this, is to make the wall four feet thick at the water line of the upper level, to secure it against filtration; and then to determine the base of the batter, so that the mass of masonry shall present sufficient stability to counteract the tendency of the pressure. The spread, and other dimensions of the foundations, will be regulated according to the nature of the soil, in the same way as in other structures.

800. The *bottom of the chamber*, as has been stated, may be either flat or curved. The flat bottom is suitable to very firm soils, which will neither yield to the vertical pressure of the chamber walls, nor admit the water to filter from the upper level under the bottom of the lock. In either of the contrary cases, the bottom should be made with an inverted arch, as this form will oppose greater resistance to the upward pressure of the water under the bottom, and will serve to distribute the weight of the walls over the portion of the foundation under the arch. The thickness of the masonry of

the bottom will depend on the width of the chamber and the nature of the soil. Were the soil a solid rock, no bottoming would be requisite; if it is of soft mud, a very solid bottoming, from three to six feet in thickness, might be requisite.

801. The principal danger to the foundations arises from the water which may filter from the upper to the lower level, under the bottom of the lock. One preventive for this, but not an effectual one, is to drive sheeting piles across the canal at the end of the head-bay; another, which is more expensive, but more certain in its effects, consists in forming a deep trench of two or three feet in width, just under the head-bay, and filling it with beton, which unites at the top with the masonry of the head-bay. Similar trenches might be placed under the chamber were it considered necessary.

802. The *lift-wall* usually receives the same thickness as the chamber walls; but, unless the soil is very firm, it would be more prudent to form a general mass of masonry under the entire head-bay, to a level with the base of the chamber foundations, of which mass the lift-wall should form a part.

803. The *head-bay* is enclosed between two parallel walls, which form a part of the side walls of the lock. They are terminated by two wing walls, which it will be found most economical to run back at right angles with the side walls. A recess, termed the *gate-chamber*, is made in the wall of the head-bay; the depth of this recess should be sufficient to allow the gate, when open, to fall two or three inches within the facing of the wall, so that it may be out of the way when a boat is passing; the length of the recess should be a few inches more than the width of the gate. That part of the recess where the gate turns on its pivot is termed the *hollow quoin*; it receives what is termed the *heel*, or *quoin-post* of the gate, which is made of a suitable form to fit the hollow quoin. The distance between the hollow quoins and the face of the lift-wall will depend on the pressure against the mitre-sill, and the strength of the stone, eighteen inches, will generally be found amply sufficient.

The side walls need not extend more than twelve inches beyond the other end of the gate-chamber. The wing walls may be extended back to the total width of the canal, but it will be more economical to narrow the canal near the lock, and to extend the wing walls only about two feet into the banks, or sides. The dimensions of the side and wing walls of the head-bay are regulated in the same way as the chamber walls.

The bottom of the head-bay is flat, and on the same level with the bottom of the canal; the exterior course of stones at the entrance to the lock should be so jointed as not to work loose.

804. The *gate-chambers* for the lower gates are made in the chamber walls; and it is to be observed, that the bottom of the chamber, where the gates swing back, should be flat, or be otherwise arranged not to impede the play of the gates.

805. The *side walls of the tail-bay* are also a part of the general side walls, and their thickness is regulated as in the preceding cases. Their length will depend chiefly on the pressure which the lower gates throw against them when the lock is full; and partly on the space required by the lock-men in opening and shutting gates manœuvred by the balance beam. A calculation must be made for each particular case, to ascertain the most suitable length. The side walls are also terminated by wing walls, similarly arranged to those of the head-bay. The points of junction between the wing and side walls should, in both cases, either be curved, or the stones at the angles be rounded off. One or two perpendicular grooves are sometimes made in the side walls of the tail-bay, to receive stop-planks, when a temporary dam is needed, to shut off the water of the lower level from the chamber, in case of repairs, etc. Similar arrangements might be made at the head-bay, but they are not indispensable in either case.

The strain on the walls at the hollow quoins is greater than at any other points, owing to the pressure at those points from the gates, when they are shut, and to the action of the gates when in motion; to counteract this, and strengthen the walls, buttresses should be placed at the back of the walls in the most favorable position behind the quoins to subserve the object in view.

The bottom of the tail-bay is arranged, in all respects, like that of the head-bay.

806. The *top of the side walls* of the lock may be from one to two feet above the general level of the water in the upper reach; the top course of the masonry being of heavy large blocks of cut stone, although this kind of coping is not indispensable, as smaller masses have been found to suit the same purpose, but they are less durable. As to the masonry of the lock in general, it is only necessary to observe that those parts alone need be of cut stone where there is great wear and tear from any cause, as at the angles generally; or

where an accurate finish is indispensable, as at the hollow quoins. The other parts may be of brick, rubble, beton, etc., but every part should be laid in the best hydraulic mortar.

807. The *filling and emptying the lock chamber* have given rise to various discussions and experiments, all of which have been reduced to the comparative advantages of letting the water in and off by valves made in the gates themselves, or by culverts in the side walls, which are opened and shut by valves. When the water is let in through valves in the gates, its effects on the sides and bottom of the chamber are found to be very injurious, particularly in high lift-walls; besides the inconvenience resulting from the agitation of the boat in the lock. To obviate this, in some degree, it has been proposed to give the lift-wall the form of an inclined curved surface, along which the water might descend without producing a shock on the bottom.

808. The *side culverts* are small arched conduits, of a circular or an elliptical cross section, which are made in the mass of masonry of the side walls, to convey the water from the upper level to the chamber. These culverts, in some cases, run the entire length of the side walls, on a level with the bottom of the chamber, from the lift-wall to the end of the tail-wall, and have several outlets leading to the chamber. They are arranged with two valves, one to close the mouth of the culvert, at the upper level, the other to close the outlet from the chamber, to the lower level. This is, perhaps, one of the best arrangements for side culverts. They all present the same difficulty in making repairs when out of order, and they are moreover very subject to accidents. They are therefore on these accounts inferior to valves in the gates.

809. It has also been proposed, to avoid the inconveniences of culverts, and the disadvantages of lift-walls, by suppressing the latter, and gradually increasing the depth of the upper level to the bottom of the chamber. This method presents a saving in the mass of masonry, but the gates will cost more, as the head and tail gates must be of the same height. It would entirely remove the objection to valves in the gates, as the current through them, in this case, would not be sufficiently strong to injure the masonry.

810. The *bottom of the canal* below the lock should be protected by what is termed an *apron*, which is a covering of plank laid on a grillage, or else one of brushwood and dry stone. The sides should also be faced with timber or dry stone. The length of this facing will depend on the strength of the

current; generally not more than from fifteen to thirty feet from the lock will require it. The entrance to the head-bay is, in some cases, similarly protected, but this is unnecessary, as the current has but a very slight effect at that point.

811. Locks constructed of timber and dry stone, termed *composite-locks*, are to be met with on several of the canals of the United States. The side walls are formed of dry stone carefully laid; the sides of the chamber being faced with plank nailed to horizontal and upright timbers, which are firmly secured to the dry stone walls. The walls rest upon a platform laid upon heavy beams placed transversely to the axis of the lock. The bottom of the chamber usually receives a double thickness of plank. The quoin-posts and mitre-sills are formed of heavy beams.

812. **Lock Gates.** A lock gate (Fig. 246) is composed of



Fig. 246—Represents the elevation of a lock-gate closed.  
*a, a*, quoin-posts.  
*b*, mitre-posts.  
*c, c*, cross pieces framed into *a* and *b*, and firmly connected with them by wrought-iron plates.  
*o*, plank or sheathing of the gate.  
*d*, valve.  
*m, m*, balance-beams.

two leaves, each leaf consisting of a solid framework covered on the side towards the water with thick plank made water-tight. The frame usually consists of two uprights, of several horizontal cross pieces let into the uprights, and sometimes a diagonal piece or brace, intended to keep the frame of an invariable form, is added. The upright, around which the leaf turns, termed the *quoin* or *heel-post*, is rounded off on the back to fit in the hollow quoin; it is made slightly eccentric with it, so that it may turn easily without rubbing against the quoin; its lower end rests on an iron *gudgeon*, to which it is fitted by a corresponding indentation in an iron *socket* on the end; the upper extremity is secured to the side walls by an iron *collar*, within which the post turns. The collar is so arranged that it can be easily fastened to, or loosened from, two iron bars,

termed *anchor-irons*, which are firmly attached by bolts, or a lead sealing, to the top course of the walls. One of the anchor-irons is placed in a line with the leaf when shut, the other in a line with it when open, to resist most effectually the strain in those two positions of the gate. The opposite upright, termed the *mitre-post*, has one edge bevelled off to fit against the mitre-post of the other leaf of the gate.

813. A long heavy beam, termed a *balance-beam*, from its partially balancing the weight of the leaf, rests on the quoin-post, to which it is secured, and is mortised with the mitre-post. The balance-beam should be about four feet above the top of the lock, to be readily manœuvred; its principal use being to open and shut the leaf.

814. The top cross piece of the gate should be about on a level with the top of the lock; the bottom cross piece should swing clear of the bottom of the lock. The position of the intermediate cross pieces may be made to depend on their dimensions: if they are of the same dimensions, they should be placed nearer together at the bottom, as the pressure of the water is there greatest; but, by making them of unequal dimensions, they may be placed at equal distances apart; this, however, is not of much importance except for large gates, and considerable depths of water.

The plank may be arranged either parallel to the uprights, or parallel to the diagonal brace; in the latter position they will act with the brace to preserve the form of the frame.

815. A wide board, supported on brackets, is often affixed to the gates, both for the manœuvre of the machinery of the valves, and to serve as a foot-bridge across the lock. The valves are small gates which are arranged to close the openings made in the gates for letting in or drawing off the water. They are arranged to slide up and down in grooves, by the aid of a rack and pinion, or a square screw; or they may be made to open or shut by turning on a vertical axis, in which case they are termed *paddle gates*. The openings in the upper gates are made between the two lowest cross pieces. In the lower gates the openings are placed just below the surface of the water in the reach. The size of the opening will depend on the time in which it is required to fill the lock.

816. **Accessory Works.** Under this head are classed those constructions which are not a part of the canal proper, although generally found necessary on all canals: as the culverts for conveying off the water-courses which intersect the line of the canal; the inlets of feeders for the supply of water; aqueduct bridges, etc., etc.

**817. Culverts.** The disposition to be made of water-courses intersecting the line of the canal will depend on their size, the character of their current, and the relative positions of the canal and stream.

Small brooks which lie lower than the canal may be conveyed under it through an ordinary culvert. If the level of the canal and brook is nearly the same, it will then be necessary to make the culvert in the shape of an inverted syphon, and it is therefore termed a *broken-back* culvert. If the water of the brook is generally limpid, and its current gentle, it may, in the last case, be received into the canal. The communication of the brook, or feeder, with the canal, should be so arranged that the water may be shut off, or let in at pleasure, in any quantity desired. For this purpose a cut is made through the side of the canal, and the sides and bottom of the cut are faced with masonry laid in hydraulic mortar. A sliding gate, fitted into two grooves made in the side walls, is manœuvred by a rack and pinion, so as to regulate the quantity of water to be let in. The water of the feeder, or brook, should first be received in a basin, or reservoir, near the canal, where it may deposit its sediment before it is drawn off. In cases where the line of the canal is crossed by a torrent, which brings down a large quantity of sand, pebbles, etc., it may be necessary to make a permanent structure over the canal, forming a channel for the torrent; but if the discharge of the torrent is only periodical, a movable channel may be arranged, for the same purpose, by constructing a boat with a deck and sides to form the water-way of the torrent. The boat is kept in a recess in the canal near the point where it is used, and is floated to its position, and sunk when wanted.

**818. Aqueducts, etc.** When the line of the canal is intersected by a wide water-course, the communication between the two shores must be effected either by a canal aqueduct bridge, or by the boats descending from the canal into the stream. As the construction of aqueduct bridges has already been considered, nothing farther on this point need here be added. The expedient of crossing the stream by the boats may be attended with many grave inconveniences in water-courses liable to freshets, or to considerable variations of level at different seasons. In these cases locks must be so arranged on each side, where the canal enters the stream, that boats may pass from the one to the other under all circumstances of difference of level between the two. The locks and the portions of the canal which join the stream must be secured



against damage from freshets by suitable embankments; and when the summer water of the stream is so low that the navigation would be impeded, a dam across the stream will be requisite to secure an adequate depth of water during this epoch.

**819. Canal-Bridges.** Bridges for roads over a canal, termed *canal-bridges*, are constructed like other structures of the same kind. In planning them the engineer should endeavor to give sufficient height to the bridge to prevent those accidents, of but too frequent occurrence, from persons standing upright on the deck of the passage-boat while passing under a bridge.

A novel device, which, on account of its diminutive size, is hardly worthy of the name of a bridge, is used for crossing the canal at Williamsport, Pennsylvania. It is really a small pivot bridge, so constructed that a boat may push it open either way as desired as it passes through, and which will close itself after the boat has passed. As it opens it moves up an inclined plane, so that its weight will aid in closing it. A weight, which is attached to a rope at one end, the rope passing over a pulley and attached to the bridge at the other, is also employed in closing it.

**820. Waste-Weir.** Waste-weirs must be made along the levels to let off the surplus water. The best position for them is at points where they can discharge into natural water courses. The best arrangement for a waste-weir is to make a cut through the side of the canal to a level with the bottom of it, so that, in case of necessity, the waste-weir may also serve for draining the level. The sides and bottom of the cut must be faced with masonry, and have grooves left in them to receive stop-plank, or a sliding gate, over which the surplus water is allowed to flow, under the usual circumstances, but which can be removed, if it be found necessary, either to let off a larger amount of water, or to drain the level completely.

**821. Temporary Dams.** In long levels an accident happening at any one point might cause serious injury to the navigation, besides a great loss of water. To prevent this, in some measure, the width of the canal may be diminished, at several points of a long level, to the width of a lock, and the sides, at these points, may be faced with masonry, arranged with grooves and stop-planks, to form a temporary dam for shutting off the water on either side.

**822. Tide, or Guard Lock.** The point at which a canal enters a river requires to be selected with judgment. Gen-

erally speaking, a bar will be found in the principal water-course at or below the points where it receives its affluents. When the canal, therefore, follows the valley of an affluent, its outlet should be placed below the bar, to render its navigation permanently secure from obstruction. A large basin is usually formed at the outlet, for the convenience of commerce; and the entrance from this basin to the canal, or from the river to the basin, is effected by means of a lock with double gates, so arranged that a boat can be passed either way, according as the level in the one is higher or lower than that in the other. A lock so arranged is termed a *tide* or *guard lock*, from its uses. The position of the tail of this lock is not indifferent in all cases where it forms the outlet to the river; for, were the tail placed up stream, it would be more difficult to pass in or out than if it were down stream.

823. The general dimensions of canals and their locks in this country and in Europe, with occasional exceptions, do not differ in any considerable degree.

**English Canals.** Two classes of canals are to be met with in England, differing materially in their dimensions. The following are the usual dimensions of the cross section of the largest size, and those of their locks:—

Width of section at the water level, from 36 to 40 feet.	
Width at bottom.....	24 “
Depth.....	5 “
Length of lock between mitre-sills.....	75 to 80 “
Width of chamber.....	15 “

The Caledonian canal, in Scotland, which connects Loch Eil on the Western sea with Murray Firth on the Eastern, is remarkable for its size, which will admit of the passage of frigates of the second class. The following are the principal dimensions of the cross section of the canal and its locks:—

Width of canal at the water level.....	110 feet.
Width at bottom.....	50 “
Depth of water... ..	20 “
Width of berm.....	6 “
Length of lock between mitre-sills.....	180 “
Width of chamber at top.....	40 “
Lift of lock.....	8 “

The side walls of the locks are built with a curved batter, they are of the uniform thickness of 6 feet, and are strengthened by counterforts, placed about 15 feet apart, which are 4 feet wide and of the same thickness. The bottom of the chamber is formed with an inverted arch.

**French Canals.** In France the following uniform system has been established for the dimensions of canals and their locks:—

Width of canal at water level.....	52 feet.
Width at bottom.....	33 to 36 “
Depth of water.....	5 “
Length of lock between mitre-sills.....	115 “
Width of lock.....	17 “

The boats adapted to these dimensions are from 105 to 108 feet long,  $16\frac{1}{2}$  feet across the beam, and have a draught of 4 feet.

Width of canal at top.....	50 feet.
Width at bottom.....	30 “
Depth of water.....	5 “
Length of locks.....	100 “
Width of locks.....	15 “

The Rideau canal, which connects Lake Ontario with the River Ottawa, is arranged for steam navigation. A considerable portion of this line consists of slack-water navigation, formed by connecting the natural water-courses between the outlets of the canal. The length of the locks on this canal is 134 feet between the mitre-sills, and their width 33 feet.

The Welland canal, between lakes Erie and Ontario, as originally constructed, received the following dimensions:—

Width of canal at top.....	56 feet.
Width at bottom.....	24 “
Depth of water.....	8 “
Length of locks between mitre-sills.....	110 “
Width of locks.....	22 “

The canals and locks made to avoid the dangerous rapids of the St. Lawrence are in all respects among the largest in the world. The following are the dimensions of the portion of the canal and the locks between Long Sault and Cornwall:—

Width of canal at top.....	132 feet.
Width at bottom.....	100 “
Depth of water.....	8 “
Width of tow-path.....	12 “
Length of locks between mitre-sills.....	200 “
Width of locks at top.....	56.6 “
Width of locks at bottom.....	43 “

A berm of 5 feet is left on each side between the water

way and the foot of the interior slope of the tow-path. The height of the tow-path is 6 feet above the berm. By increasing the depth of water in the canal to 10 feet, the water-line at top can be increased to 150 feet.

The dimensions of the Erie canal as enlarged are:—

Width of canal at top, with bench walls...	81 feet.
Width of canal at top, without bench walls.	75 "
Width of canal at water surface.....	70 "
Width of canal at bottom, with bench walls.	42 "
Width of canal at bottom, without bench walls.....	52 $\frac{1}{3}$ "
Depth of water.....	7 "
Width of tow-path.....	14 "
Width of locks at top.....	18 " 10 in.
Width of locks at bottom.....	17 " 4 $\frac{1}{2}$ in.
Length of lock (between mitre-sills).....	110 "

**824. Locomotion on Canals.** In early times boats were drawn or pushed along by servants or slaves. In civilized countries horses and mules have been chiefly used. A few years since several attempts were made to use steam power, by driving the boat like a propeller, and although it would do the work, yet it was mostly abandoned after a few months. The wheel created such a disturbance in the water as caused it to wash the banks and thus damage them.

A system, known as the *Belgian system*, has been quite extensively used in some of the European countries. It consists of a cable which passes from one end of the canal to the other, and is sunk in it. It is wound around a wheel which is at one end of the boat. Steam power is applied to turn the wheel, and, as the friction of the rope on the wheel prevents it from slipping, it will take up the cable on one side of the wheel and let it out on the other, and thus draw the boat along. One of the objections to this plan is, it requires a large amount of slack cable to accommodate a large traffic, and every boat must draw in all the slack every time it passes over the canal.

During the winter of 1870-71 the Legislature of the State of New York offered a prize of \$100,000 to the party who would make an acceptable mode of applying steam for propelling canal boats on the canals, and no plan was to be considered which involved the Belgian system. The engineer in charge of this project states that in round numbers a thousand plans, coming from all parts of the world, have been presented, but up to the present time the prize has not been awarded.

## CHAPTER IX.

## RIVERS.

825. *Natural features of Rivers.* All rivers present the same natural features and phenomena, which are more or less strongly marked and diversified by the character of the region through which they flow. Taking their rise in the highlands, and gradually descending thence to some lake, or sea, their beds are modified by the nature of the soil of the valleys in which they lie, and the velocities of their currents are affected by the same cause. Near their sources, their beds are usually rocky, irregular, narrow, and steep, and their currents are rapid. Approaching their outlets, the beds become wider and more regular, the declivity less, and the current more gentle and uniform. In the upper portions of the beds, their direction is more direct, and the obstructions met with are usually of a permanent character, arising from the inequalities of the bottom. In the lower portions, the beds assume a more tortuous course, winding through their valleys, and forming those abrupt bends, termed *elbows*, which seem subject to no fixed laws; and here are found those obstructions, of a more changeable character, termed *bars*, which are caused by deposits in the bed, arising from the wear of the banks by the current.

826. The relations which are found to exist between the cross section of a river, its longitudinal slope, the nature of its bed, and its volume of water, are termed the *regimen* of the river. When these relations remain permanently invariable, or change insensibly with time, the river is said to have a *fixed regimen*.

Most rivers acquire in time a fixed regimen, although periodically, and sometimes accidentally, subject to changes from freshets caused by the melting of snow, and heavy falls of rain. These variations in the volume of water thrown into the bed cause corresponding changes in the velocity of the current, and in the form and dimensions of the bed. These changes will depend on the character of the soil, and the width of the valley. In narrow valleys, where the banks do not readily yield to the action of the current, the effects of

any variation of velocity will only be temporarily to deepen the bed. In wide valleys, where the soil of the banks is more easily worn by the current than the bottom, any increase in the volume of water will widen the bed; and if one bank yields more than the other, an elbow will be formed, and the position of the bed will be gradually shifted towards the concave side of the elbow.

827. The formation of elbows occasions also variations in the depth and velocity of the water. The greatest depth is found at the concave side. At the straight portions which connect two elbows, the depth is found to decrease, and the velocity of the current to increase. The bottom of the bed thus presents a series of undulations, forming shallows and deep pools, with rapid and gentle currents.

828. Bars are formed at those points, where from any cause the velocity of the current receives a sudden check. The particles suspended in the water, or borne along over the bottom of the bed by the current, are deposited at these points, and continue to accumulate, until, by the gradual filling of the bed, the water acquires sufficient velocity to bear farther on the particles that reach the bar, when the river at this point acquires and retains a fixed regimen, until disturbed by some new cause.

829. The points at which these changes of velocity usually take place, and near which bars are found, are at the junction of a river with its affluents, at those points where the bed of the river receives a considerable increase in width, at the straight portions of the bed between elbows, and at the outlet of the river to the sea. The character of the bars will depend upon that of the soil of the banks, and the velocity of the current. Generally speaking, the bars in the upper portions of the bed will be composed of particles which are larger than those by which they are formed lower down. These accumulations at the mouths of large rivers form in time extensive shallows, and great obstructions to the discharge of the water during the seasons of freshets. The river then, not finding a sufficient outlet by the ordinary channel, excavates for itself others through the most yielding parts of the deposits. In this manner are formed those features which characterize the outlets of many large rivers, and which are termed *delta*, after the name given to the peculiar shape of the outlets of the Nile.

830. **River Improvements.** There is no subject that falls within the province of the engineer's art, that presents greater difficulties and more uncertain issues than the im-

provement of rivers. Ever subject to important changes in their regimen, as the regions by which they are fed are cleared of their forests and brought under cultivation, one century sees them deep, flowing with an equable current, and liable only to a gradual increase in volume during the seasons of freshets; while the next finds their beds a prey to sudden and great freshets, which leave them, after their violent passage, obstructed by ever shifting bars and elbows. Besides these revolutions brought about in the course of years, every obstruction temporarily placed in the way of the current, every attempt to guard one point from its action by any artificial means, inevitably produces some corresponding change at another, which can seldom be foreseen, and for which the remedy applied may prove but a new cause of harm. Thus, a bar removed from one point is found gradually to form lower down; one bank protected from the current's force transfers its action to the opposite one, on any increase of volume from freshets, widening the bed, and frequently giving a new direction to the channel. Owing to these ever varying causes of change, the best weighed plans of river improvement sometimes result in complete failure.

831. In forming a plan for a river improvement, the principal objects to be considered by the engineer, are, 1st. The means to be taken to protect the banks from the action of the current. 2d. Those to prevent inundations of the surrounding country. 3d. The removal of bars, elbows and other natural obstructions to navigation. 4th. The means to be resorted to for obtaining a suitable depth of water for boats, of a proper tonnage, for the trade on the river.

832. The erosion of the banks of rivers is often the main cause of changes in their regimen, such as the formation of sand banks, opening new channels, change of thalweg. This erosion, moreover, is very prejudicial to adjoining property, and should be strongly opposed. Various means for attaining this end are used. Among these are rip-rap, or random stone, paving the banks, plantations, timber revetment, coverings of fascines, and finally, projecting works called wing-dams, spurs, jetties, or dykes.

1st. *Rip-rap*.—Rip-rap, or random stone, carefully put down and properly kept up, is very effective. It may be economical to use it when stone can be easily obtained. A trench should be dug at the foot of the bank and carried below any expected scour. The stone should then be thrown in, with the smallest pieces at the bottom, and increasing in size to the top.

The blocks on top should be heavy enough to prevent their being washed away by the current.

2d. *Paving*.—Pavements, or stone revetments, may be either of dry stone or of stone laid in hydraulic mortar. Dry stone has the advantage of readily adapting itself to the shape of the ground, but it has also the great disadvantage of falling in entirely in case the foot should be attacked. With good hydraulic masonry a thinner pavement and smaller stones may be used, and when a scour takes place at the foot, the upper part of the revetment forms an arch which may stand by itself until repairs are made. Whatever system be followed, the foot of the pavement should be well protected with rip-rap and the foundation should be put down with great care.

3d. *Plantations*.—Plantations also give a good protection, especially for the upper part of the banks. The common water willow is excellent for this purpose. It grows quickly and spreads rapidly. Willow sticks, about a foot and a half long and an inch in diameter, are stuck a foot into the ground along the bank. At the end of three or four years the plantation will have become a small wood, which will break the current. If it be desired to make ground, the larger branches toward the water may be cut half through, the upper end pointed and stuck in the ground. This growth becomes very thick, and the water within it almost stagnant. At each rise of the river a certain amount of deposit takes place, and the new ground is quickly made. On the Ohio it has been found that willows do not grow below the six-foot stage; consequently they afford no protection below that limit. They are mainly useful to prevent the wash of waves and steamboats.

4th. *Timber revetments*.—These are only mentioned because they may serve a good purpose in an emergency for some threatened point, but for general work they are too perishable to be of much value.

5th. *Fascines*.—In some countries a great deal has been done for the protection of banks by means of revetments of fascines. The elements of fascine work are pickets, fascines of large and small size, saplings, fascine rafts or mattresses, hurdles, reeds and straw. In France, on the Rhine, fascines have been employed to a great extent. This system is now but little used, on account of the cost of materials and labor, which have both increased very much; on the other hand, transportation has now become easy and cheap. Were works like those on the Rhine to be built to-day, large use



would doubtless be made of masonry and rip-rap, as these could be easily carried by rail.

6th. *Wing-dams*.—For the protection of the banks of the Rhine projecting fascine works were formerly used. These were called wing-dams, spurs, or jetties, and were placed normal to the direction of the current. It was found that they were frequently undermined by the scour at the outer end, and in some cases, when not very securely rooted to the bank, the river cut around behind them. The result of experience in the use of wing-dams has led to their abandonment to a great extent. However, it must be acknowledged that wing-dams have given good results on several rivers where they have been properly built and arranged, and where care has been taken to give them an inclination in the direction of the current. On the Ohio river a number of dykes, or wing-dams, nearly parallel to the current, have been built with excellent results.

**833. Measures against inundations.**—Many ways of overcoming floods, and preventing the disasters that arise therefrom, have been proposed. None, however, have been entirely successful, and, in the present state of science, the question seems to have no certain solution. The various systems proposed are as follows: 1st, to build reservoirs for holding back the hurtful part of floods and checking the flow of the water; 2d, levees or embankments raised along the sides of the river; 3d, cut-off canals and horizontal ditches, weirs; 4th, re-wooding and resodding hills and mountains.

1st. *Reservoirs*.—Damage by floods arises from two causes, the volume of the water and its velocity. The former acts by submerging buildings, crops, etc.; the latter by cutting away the land, carrying away structures of various kinds. Of these the velocity is probably the more destructive, and the remedy is to lessen the velocity. This the partisans of the reservoir system claim can be best accomplished by means of storing the greater part of the flood, and, when it subsides, letting off gradually the accumulated water. The opponents of the system claim that it would be impossible to build reservoirs of sufficient capacity to hold back any appreciable part of the falling water. Furthermore, the water held in check on one tributary might be let loose just in time to meet that coming out of another, and thus make the second flood much worse. The cost of these reservoirs would be enormous, and, as their necessity is felt but rarely, the expense would not be justified by the value of the property protected. If built across a large river, they would be very dangerous and difficult to build.

They would submerge valuable land, stop rafting, etc., when half full, interfere with railroads in the valley, etc.

2d. *Levees*.—The question of the efficacy of levees or longitudinal embankments is still a point entirely unsettled by engineers, and it seems to be one for which there is no satisfactory solution. Levees have been used for many years on the Mississippi, on the Po, on the Rhine, in Hungary, and elsewhere. They seem to be the most natural protection against floods and the one that would probably be first adopted. By confining the water-way of a river the height of floods is necessarily increased; therefore levees, when used, should not be placed too near each other. Keeping the water off the land prevents the deposit of the soil brought from other points, which might tend to enrich the ground if allowed to settle thereon. The banks of all rivers in alluvial lands are highest near the river, consequently whenever a levee is undermined if a new one be built it must be on lower ground, and therefore higher and more expensive. The question of levees must be carefully studied for the particular locality to be protected.

3d. *Cut-off canals and horizontal ditches*.—The idea of cut-off canals, whereby the water of a freshet can be drawn away from the river, is very pleasing and apparently very feasible, but when it is examined in detail several serious objections are encountered. The cost would be very great. To obtain any slope for them the entrance for the water would have to be placed so far up stream that only a small portion of the surplus water could be taken. To find an outlet is still more difficult. If the canal be not continued to the sea it would have to be returned to the river, and the evil would only be changed from one point to another. Nearly the same objections apply to horizontal ditches cut in the side slopes of the valley of the stream. The water would have to return to the river and the evil would be unabated.

4th. *Rewooding and resodding hill-sides*.—While it is not yet conclusively shown that forests have any special influence on the amount of rain-fall, it is now generally admitted that they have a great bearing on freshets, because they hold back a great deal of water from the ground, and what does fall is made to pass off gradually instead of suddenly, as is the case in unwooded countries. Sod has much the same effect as woods. Covering the ground with woods and grass increases the length of the freshet, and consequently checks its violence.

834. *Elbows*. The constant wear of the bank, and shifting of the channel towards the concave side of elbows, have

led to various plans for removing the inconveniences which they present to navigation. The method which has been most generally tried for this purpose consists in building out dykes, termed *wing-dams*, from the concave side into the stream, placing them either at right angles to the thread of the current, or obliquely down stream, so as to deflect the current towards the opposite shore.

Wing-dams are usually constructed either of blocks of stone, of crib-work formed of heavy timbers filled in with broken stone, or of alternate layers of gravel and fascines.

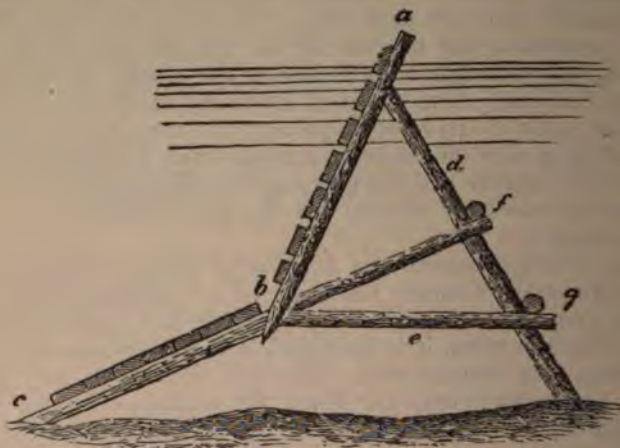

Fig. 247—Represents a section of the timber wing-dams on the Po, formed of plank nailed on the inclined pieces of the ribs.  
*a b* and *b c*, inclined faces of the dam, the first making an angle of  $63^\circ$ , and the second of  $23^\circ$  with the horizon.  
*d* and *e* pieces of the rib.  
*f* and *g* horizontal pieces connecting the ribs.

Within a few years back, wing-dams, consisting simply of a series of vertical frames, or ribs (Fig. 247), strongly connected together, and covered on the up-stream side by thick plank, which present a broken inclined plane to the current, the lower part of which is less steep than the upper, have been used upon the Po, with, it is stated, complete success, for arresting the wear of a bank by the current. These dams are placed at some distance above the point to be protected, and their plan is slightly convex on the up-stream side.

Wing-dams of the ordinary form and construction are now regarded, from the experience of a long series of years on the

Rhine and some other rivers in Europe, as little serviceable, if not positively hurtful, as a river improvement, and the abandonment of their use has been strongly urged by engineers in France.

The action of the current against the side of the dam causes whirls and counter-currents, which are found to undermine the base of the dam, and the bank adjacent to it. Shallows and bars are formed in the bed of the stream, near the dam, by the *débris borne* along by the current after it passes the dam, giving very frequently a more tortuous course to the channel than it had naturally assumed in the elbow. The best method yet found of arresting the progress of an elbow is to protect the concave bank by a facing of dry stone, formed by throwing in loose blocks of stone along the foot of the bank, and giving them the slope they naturally assume when thus thrown in.

Wing-walls were put into the Hudson River many years since for the purpose of removing the bars and improving the stream for navigable purposes. The result has been that they produced a scour in the narrowed part of the stream, which removed the sand and other materials of the bar to points lower down in the stream, where it was again deposited; thus removing the previous obstruction only to produce a worse one in a new place.

Gen. Totten, in an able report to the Government on the improvement of rivers having bars, showed very clearly the error of attempting to improve rivers by means of wing-dams. He recommended the establishment of a uniform channel by *longitudinal* dykes, made of continuous piles or of walls of masonry. This plan has been adopted more recently and with good results.

835. Elbows upon most rivers finally reach that state of development in which the wear upon the concave side, from the action of the current, will be entirely suspended, and the regimen of the river at these points will remain stable. This state will depend upon the nature of the soil of the banks and bed, and the character of the freshets. From observations made upon the Rhine, it is stated that elbows, with a radius of curvature of nearly 3,000 yards, preserve a fixed regimen; and that the banks of those which have a radius of about 1,500 yards are seldom injured, if properly faced.

836. Attempts have, in some cases, been made to shorten and straighten the course of a river, by cutting across the tongue of land that forms the convex bank of the elbow, and turning the water into a new channel. It has generally been

found that the stream in time forms for itself a new bed of nearly the same character as it originally had.

**837. Bars.**—To obtain a sufficient depth of water over bars, the deposit must either be scooped up by machinery and be conveyed away, or be removed by giving an increased velocity to the current. When the latter plan is preferred, an artificial channel is formed, by contracting the natural way, confining it between two low dykes, which should rise only a little above the ordinary level of low water, so that a sufficient outlet may be left for the water during the season of freshets, by allowing it to flow over the dams.

If the river separates into several channels at the bar, dams should be built across all except the main channel, so that by throwing the whole of the water into it the effects of the current may be greater upon the bed.

The longitudinal dykes, between which the main channel is confined, should be placed as nearly as practicable in the direction which the channel has naturally assumed. If it be deemed advisable to change the position of the channel, it should be shifted to that side of the bed which will yield most readily to the action of the current.

**838.** In situations where large reservoirs can be formed near the bar, the water from them may be used for removing it. For this purpose an outlet is made from the reservoir, in the direction of the bar, which is closed by a gate that turns upon a vertical axis, and is so arranged that it can be suddenly thrown open to let off the water. The chase of water formed in this way sweeping over the bar will prevent the accumulation of deposits upon it. This plan is frequently resorted to in Europe for the removal of deposits that accumulate at the mouth of harbors in those localities where, from the height to which the tide rises, a great head of water can be obtained in the reservoirs.

**839.** In the improvement of the mouths of rivers which empty into the sea through several channels, no obstruction should be placed to the free ingress of the tides through all the channels. If the main channel is subject to obstructions from deposits, dams should be built across the secondary channels, which may be so arranged with cuts through them, closed by gates, that the flood-tide will meet with no obstruction from the gates, while the ebb-tide, causing the gates to close, will be forced to recede through the main channel, which, in this way, will be daily scoured, and freed from deposits by the ebb current. The same object may be effected by building dams without inlets across the secondary channels,

giving them such a height that at a certain stage of the flood-tide the water will flow over them and fill the channels above the dams. The portion of water thus dammed in will be forced through the main channel at the ebb.

840. When the bed is obstructed by rocks, it may be deepened by blasting the rocks, and removing the fragments with the assistance of the diving-bell and other machinery.

841. In some of our rivers obstructions of a very dangerous character to boats are met with, in the trunks of large trees which are embedded in the bottom at one end, while the other is near the surface; they are termed *snags* and *sawyers* by the boatmen. These obstructions have been very successfully removed, within late years, by means of machinery, and by propelling two heavy boats, moved by steam, which are connected by a strong beam across their bows, so that the beam will strike the snag, and either break it off near the bottom or uproot it. Other obstructions, termed *rafts*, formed by the accumulation of drift-wood at points of a river's course, are also found in some of our western rivers. These are also in process of removal, by cutting through them by various means which have been found successful.

842. **Slack-water Navigation.**—When the general depth of water in a river is insufficient for the draught of boats of the most suitable size for the trade on it, an improvement, termed *slack-water* or *lock and dam navigation*, is resorted to. This consists in dividing the course into several suitable ponds, by forming dams to keep the water in the pond at a constant head; and by passing from one pond to another by locks at the ends of the dams.

843. The position of the dams, and the number required will depend upon the locality. In streams subject to heavy freshets, it will generally be advisable to place the dams at the widest parts of the bed, to obtain the greatest outlet for the water over the dam. The dams may be built either in a straight line between the banks and perpendicular to the thread of the current, or they may be in a straight line oblique to the current, or their plan may be curved, the convex surface being up-stream, or it may be a broken line presenting an angle up-stream. The last three forms offer a greater outlet than the first to the water that flows over the dam, but are more liable to cause injury to the bed below the stream, from the oblique direction which the current may receive, arising from the form of the dam at top.

844. The cross section of a dam is usually trapezoidal, the face up-stream being inclined, and the one down-stream

either vertical or inclined. When the down-stream face is vertical, the velocity of the water which flows over the dam is destroyed by the shock against the water of the pond below the dam, but whirls are formed which are more destructive to the bed than would be the action of the current upon it along the inclined face of a dam. In all cases the sides and bed of the stream, for some distance below the dam, should be protected from the action of the current by a facing of dry stone, timber, or any other construction of sufficient durability for the object in view.

845. The dams should receive a sufficient height only to maintain the requisite depth of water in the ponds for the purposes of navigation. Any material at hand, offering sufficient durability against the action of the water, may be resorted to in their construction. Dams of alternate layers of brush and gravel, with a facing of plank, fascines, or dry stone, answer very well in gentle currents. If the dam is exposed to heavy freshets, to shocks of ice, and other heavy floating bodies, as drift-wood, it would be more prudent to form it of dry stone entirely, or of crib-work filled with stone; or, if the last material cannot be obtained, of a solid crib-work alone. If the dam is to be made water-tight, sand and gravel in sufficient quantity may be thrown in against it in the upper pond. The points where the dam joins the banks, which are termed the *roots* of the dam, require particular attention to prevent the water from filtering around them. The ordinary precaution for this is to build the dam some distance back into the banks.

846. The safest means of communication between the ponds is by an ordinary lock. It should be placed at one extremity of the dam, an excavation in the bank being made for it, to secure it from damage by floating bodies brought down by the current. The sides of the lock and a portion of the dam near it should be raised sufficiently high to prevent them from being overflowed by the heaviest freshets. When the height to which the freshets rise is great, the leaves of the head gates should be formed of two parts, as a single leaf would, from its size, be too unwieldy, the lower portion being of a suitable height for the ordinary manœuvres of the lock; the upper, being used only during the freshets, are so arranged that their bottom cross pieces shall rest, when the gates are closed, against the top of the lower portions. An arrangement somewhat similar to this may be made for the tail gates, when the lifts of the locks are great, to avoid the difficulty of manœuvring very high gates, by permanently

closing the upper part of the entrance to the lock at the tail gates, either by a wall built between the side walls, or by a permanent framework, below which a sufficient height is left for the boats to pass.

847. The fixed dams used in slack water navigation present one great objection, viz., that during periods of medium high water all navigation must pass through the locks, although the amount of water in the river might be quite sufficient for a natural navigation were the dams not built. This is a great drawback to the system because each lockage causes a delay.

The movable dams that have been for a number of years in use in France remove this difficulty. These dams are so constructed that during high water they may be laid down on a floor, built in the bed of the river, where they are wholly out of the way, and in times of low water they are raised up and form a dam.

Movable dams are divided into two or more parts, the floors of these different parts being raised one above the other, forming a series of steps. The one with the lowest floor is called the navigable pass and is usually placed alongside of the lock. The other parts are called weirs. The pass serves for the purposes of navigation during medium stages; the object of the weirs is to control the water in the pool so as to keep the latter as nearly as possible at a constant level.

848. Movable dams may be divided into two general classes: 1st, Those manœuvred by means of power applied through machinery of any kind; 2d, those manœuvred by the direct pressure of the water.

Of the first class, the systems most in use are the Poirée trestle and needle dam and the Chanoine wicket dam. The Boulé dam of trestles and sliding gates is less common. Of the second class, the bear-trap, the Desfontaines, and the Girard dams, may be regarded as types.

849. The Poirée dam consists of a number of trapezoidal shaped trestles placed across the stream parallel to its axis, and about four feet apart. They are securely fastened to the floor at the bottom and connected together at the top by means of connecting-bars, against the up-stream one of which are supported the upper ends of the needles, which have their lower ends resting against a sill in the floor. The bottom member of the trapezoid has a journal at each end which fits into a box set to receive it in the floor of the dam. The up-stream member is nearly or quite vertical, the top member is horizontal and about two-thirds the length of the bottom piece, the down-stream member reaches from the down-stream end



of the bottom to the same end of the top member. A brace extends from the upper up-stream corner to the lower down-stream corner. The up-stream and down-stream members

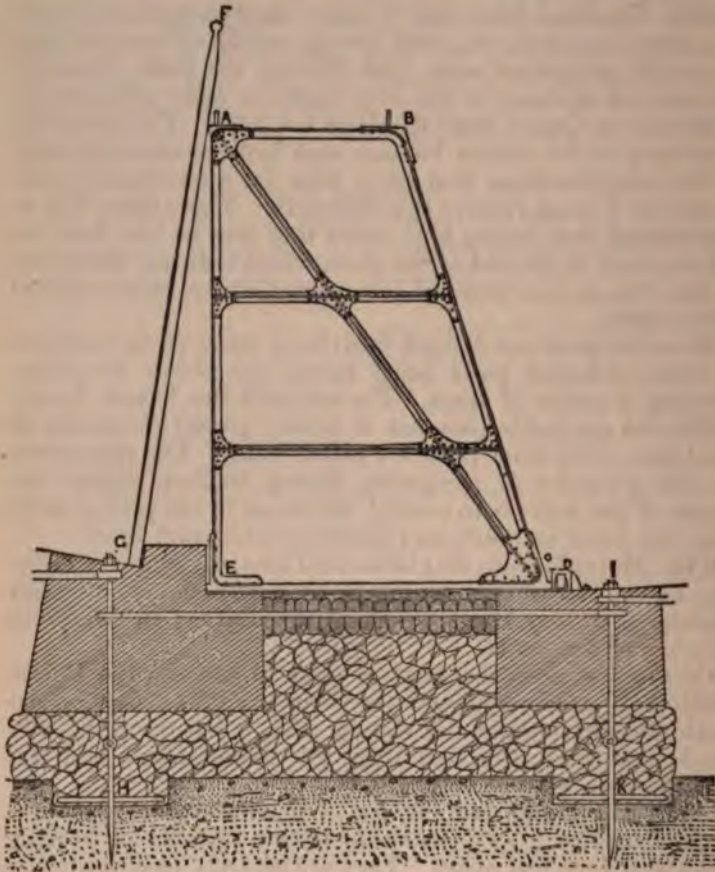

Fig. 248.—Elevation of trestle and needle of the Martot dam on the Seine. A B C E, is the trestle; A B, the cap; B C, down-stream stile; A E, up-stream stile; E C, axle; A C, brace; D, down-stream journal box; F G, needle; G H and I K, anchorages.

are called uprights or stiles, the bottom member is called the axle, and the top member is called the cap. The trestles revolve about the axle, the direction of the revolution being perpendicular to the axis of the current. When standing up the trestles are generally fastened together at the top by means of two con-

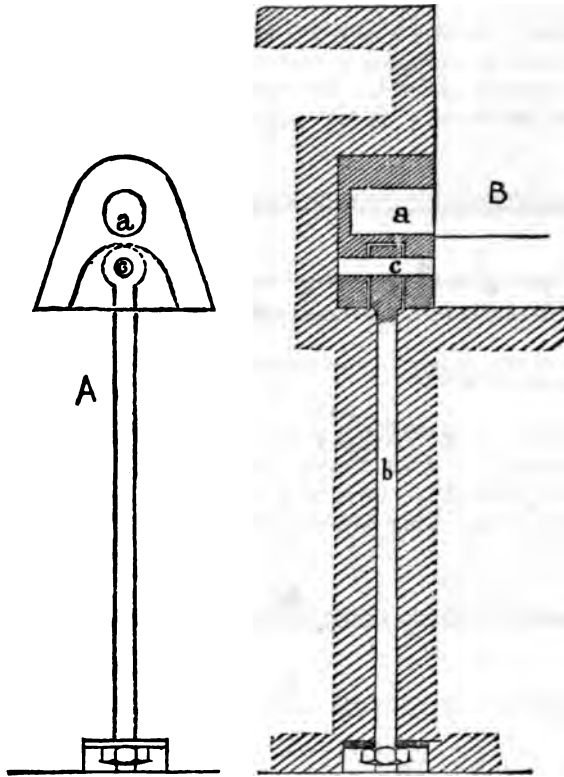

Fig. 249.—A, elevation, and B, section of up-stream anchorage of trestle; a, recess in journal-box to receive journal of trestle; b, holding-down bolt; c, steel pin connecting journal-box and bolt.

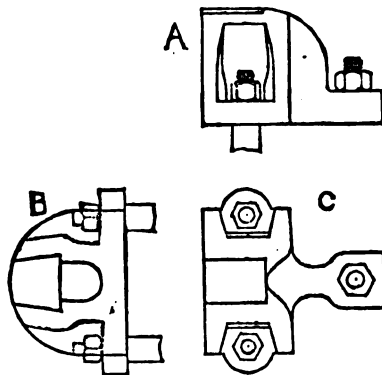

Fig. 250.—A, side elevation; B, front elevation; and C, plan of down-stream journal-box.

necting bars, one of which extends from the up-stream corner of one trestle to the same corner of the next, the other joins the down-stream corners. The up-stream bar is the stronger because it has to support the upper ends of the needles that

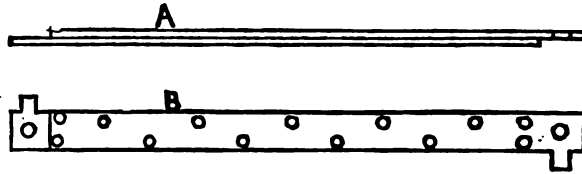

Fig. 251.—A, elevation: B, plan of up-stream connecting bar. The holes at the ends of the bar fit on pins, A, Fig. 248.

form the dam. The needles are pieces of straight wood from six to thirteen or even fifteen feet in length. Their cross-section is generally square, and varies from three to eight inches on a side. They are supported at their upper ends by

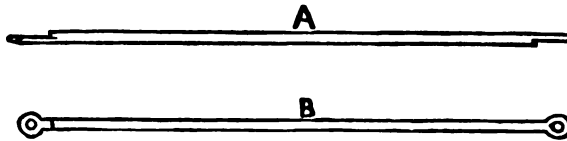

Fig. 253.—A, elevation: B, plan of down-stream connecting bar. The holes at the ends of the bar fit on pins, B, Fig. 248.

the up-stream connecting bar, and at their lower ends by a sill set in the floor of the dam. On the top of the trestles are laid planks, forming a bridge from which the needles are handled.

850. A good deal of leakage takes place between the needles, and many ways of meeting the trouble have been proposed. Among these is to make the alternate needles of a T shape, the arms of the T overlapping the needles on either side. A second is to arm the alternate needles with a strip of India rubber that should cover the intervals on either side. A third is to make the shape of the cross section of the needles that of a regular or semi-regular hexagon and to arrange them in one or two rows. To hang curtains of tarpaulins on the face of the dam has also been suggested. All these arrangements have been abandoned, and the square needles are now used as much more convenient and easy to

handle, and as making a dam that is sufficiently tight for all practical purposes.

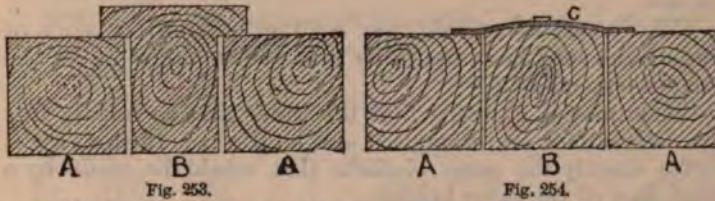

Fig. 253.—T-needle B covering intervals between it and ordinary needles, A A.  
Fig. 254.—Needle B, with india-rubber facing, C, covering intervals between B and A A.

851. The manœuvres of a needle dam are two, viz., to close and to open it. To describe the first operation we will suppose the dam to be entirely open, the trestles lying down on the floor. The dam tenders begin to work on the uppermost trestle. This trestle is grappled for by means of a hook with a long handle. If the trestle be light it can be raised by hand. If it be heavy a strong line or chain is attached by one end to a ring in the handle of the hook and by the other to the drum of a small windlass. When the trestle is nearly up, one man seizes it with a small hand-bar which has two notches or claws made in it at the exact distance apart of the

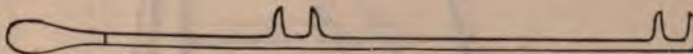

Fig. 255.—Hand-bar used to connect trestle last raised to the preceding until deck planks and connecting bars can be laid.

tops of the trestles when up. This hand-bar holds the trestle temporarily until the planks that form the deck of the bridge are laid and the connecting bars put in place. The windlass is then moved forward and the second trestle grappled for and raised in the same way, and so on to the end. When the last trestle is raised and secured the needles are put in place one by one from the bridge thus constructed. In some cases the caps of the trestles are connected together by a chain leading from one to the next. This chain is long enough to reach from one to the other when the first is standing up and the second is lying down. This saves the trouble of grappling for the trestles, which always causes the loss of more or less time.

To open the dam the needles are first removed. The hand-bar is placed on the last two trestles, the connecting bars and the planks are taken up and the last trestle is laid down.

The others go down in succession, care being taken to let them down easily, because if allowed to fall they might be broken.

852. In case of a slight rise coming in the river, some of the needles may be temporarily removed in order to let the surplus water pass off.

Sometimes it happens that the water rises so rapidly that the dam cannot be dismantled and let down. In this case it forms exactly the same obstacle that would be made by a fixed dam of the same height.

853. To protect the dam tenders in their operations by night, or in stormy weather, a sort of hand-rail is placed on

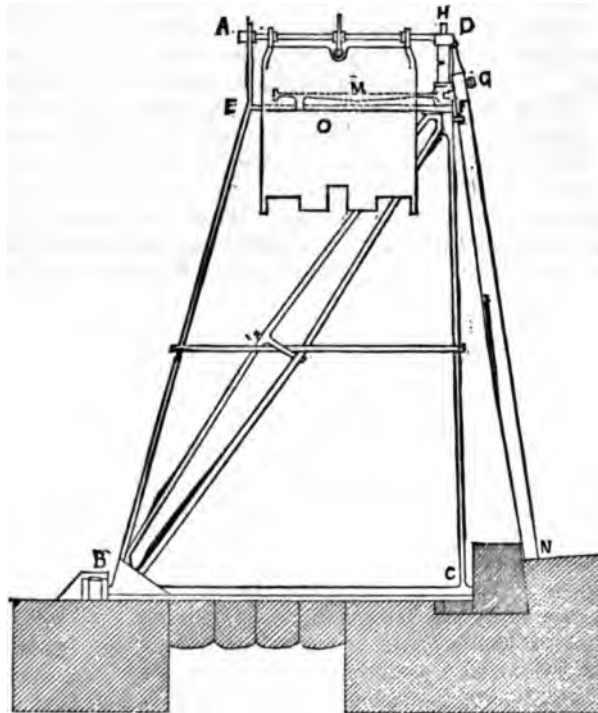

Fig. 256.—Side elevation of trestle on the Belgian Meuse. E B O F, trestle; B E, down-stream stile; O F, up-stream stile; E F, cap; B C, axle; M, movable bar resting against cap; O, attached floor; A D, axle of floor; H, square end of jack-post; G N, needle; G, eye on needle.

one side or other of the trestles, the down-stream side being the better, on account of interfering less with handling the

needles. This hand-rail is formed of a line passing through eyes at the top of vertical pieces set in the trestle at the upper down-stream corner.

854. Two objections to this system are the number of pieces to be handled in connecting the trestles and laying the deck of the bridge, and the small distance between the surface of the water and the bridge.

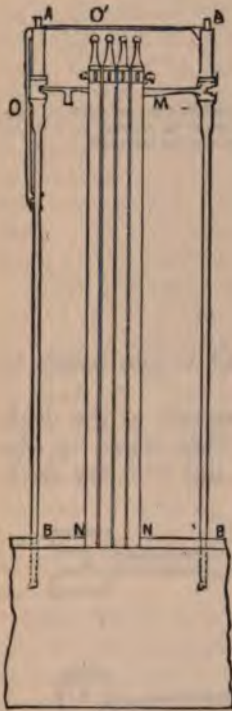

Fig. 257.

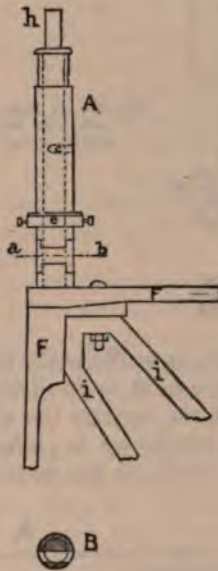

Fig. 258.



Fig. 259.

Fig. 257.—Front elevation of section of dam on the Meuse. A B, trestles; O, floor folded against side of trestle; O', floor connecting trestles; M, movable bar supporting needles; G N, needles; G G, eyes of needles.

Fig. 258.—A, enlarged side elevation of upper up-stream corner of trestle; F F, trestle; i i, brace; A, end of jack-post in place in tube; c, slot for set-screw of jack-post; e, collar for movable bar; B, section on a b showing tube and jack-post when the escapement is open.

Fig. 259.—A, front elevation of above; B, section on a b; C, section on c d. Both sections show position of jack-post with escapement open.

These objections have been very ingeniously met on the Belgian Meuse by making the deck of the bridge of sheet-iron, stiffened at the sides by means of pieces of bar iron. These stiffening pieces are made with an eye at one end and

a claw at the other. Through the eyes passes an axle which is attached to the top of the trestle by a prolongation of the down-stream stile on the one side, and on the other by a tube welded to the cap. A chain reaches from the free end of the attached deck of one trestle to the axle of the deck of the

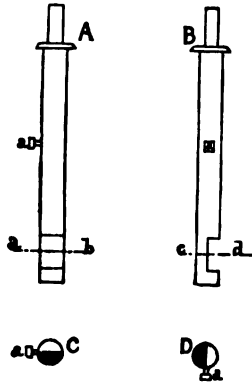

Fig. 260.—A, front elevation, and B, side elevation of jack-post, with escapement closed; C, section on *a b*; D, section on *c d*. In all four *a* is the set screw.

next. This chain is sufficiently long to allow one trestle to be upright and the next to lie down.

To raise one of the trestles the chain fastened to the deck axle of the one already up is pulled in. This draws up the free end of the deck of the next trestle, and with the deck

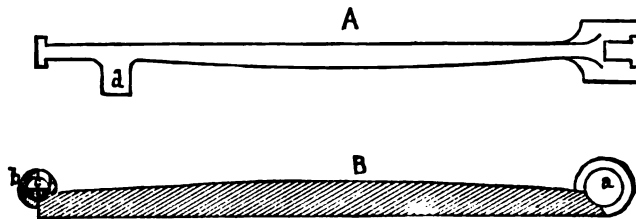

Fig. 261.—A, elevation, and B, horizontal section of movable bar; *a*, eye that fits the tube; *b*, tube, and *c*, jack-post of next trestle with escapement closed; *d*, arm to stop movable bar at cap of trestle when the escapement is opened.

comes the trestle to which it is attached. When the rising trestle is up the claws of its section of the deck are engaged on the deck axle of the preceding, and the movement is finished.

The bar that supports the upper end of the needles is no longer a connecting bar. It simply swings around the tube that forms the up-stream support of the deck axle.

**855. Escapements.** Sometimes it is necessary to let all the needles between two trestles go at once. A special arrangement, called an escapement, is made for this. These escapements are of various kinds. That used on the Belgian Meuse is thus arranged: on the interior of the tube is placed a jack-post, which projects a little above the deck. This projecting end is made square, so that a wrench may be applied to it. The jack-post is cut half way through near the bottom for a length of nearly three inches. It is movable within the tube, and is held in its place by means of a set-screw near the middle of its height. This set-screw moves in a slot cut one-quarter round the tube. The jack-post is thus prevented from moving lengthwise, and at the same time is only allowed to make a quarter revolution inside of the tube. A slot similar to that in the jack-post is also made in the tube on the side towards the trestle of which it receives the claws of the deck. The movable bar has also a slot corresponding to those of the jack-post and tube.

When the escapement is closed the slot of the jack-post is turned down-stream. The movable bar of the next trestle is thus prevented from passing through the slots of the tube and its movable bar. The needles are supported by the movable bar and sill. The bar has near its free end a small projecting arm which prevents it from swinging past the cap of the trestle. The needles are provided each with an eye near the upper end. A line is passed through these eyes to hold the needles from being lost when they are allowed to go. This line is passed under the deck and then fastened to a cable, which is attached either to the bridge or to a pier or abutment.

**856.** When it is desired to open the dam the wrench is applied to the square projecting end of the jack-post, which is turned quarter round, so that its slot may coincide with those of the tube and movable bar. The bar of the next trestle, having then no support at the free end, is carried away by the pressure of the water transmitted through the needles. The latter are carried down between the trestles, and are kept from drifting away by means of the line.

There are other kinds of escapement in use which it is needless to describe. The system of the Belgian Meuse is the best, because it is the least complicated in its workings, and leaves the bridge intact after the support of the needles is removed.

**857. Chanoine Wicket Dam.**—This dam consists of a series of panels, three or four feet wide, each independent of



those alongside, and separated from them by an interval of about four inches. These panels are of wood, rectangular in shape, and free to oscillate about the head of a frame called

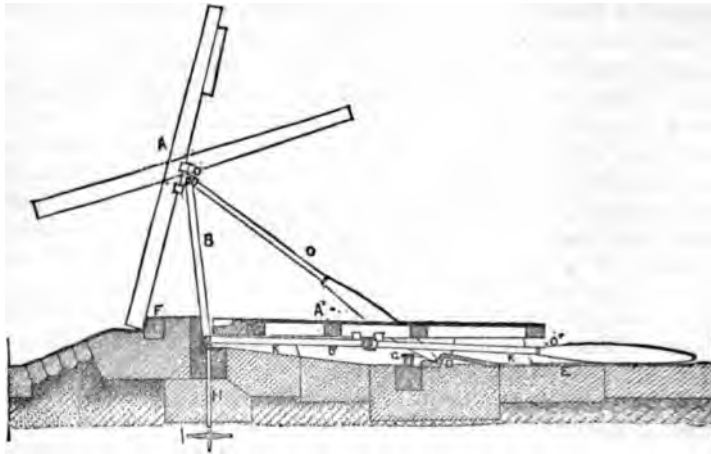

Fig. 262.—Section of Chanoine dam, showing wicket down, up, and swung. A, panel; B, horse; C, prop; D, hurter; E, slide; F, sill; G, trip-bar; H, anchoring bolt; I, anchoring disc; K K, pillows; O, axis of oscillation. A', B', C' show panel, horse, and prop when down. Dotted lines show panel swung.

the *horse*. The horse revolves about an axle at its bottom. To the head of the horse is fastened a long *prop*, the lower

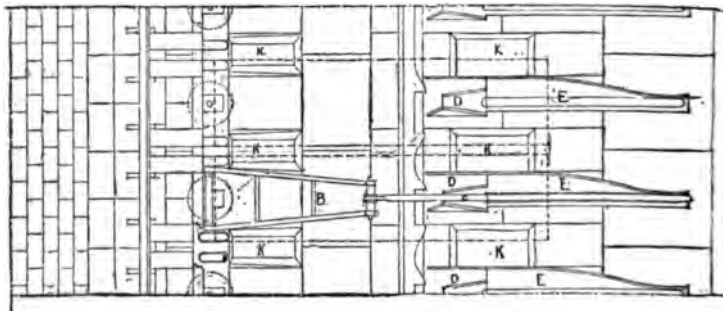

Fig. 263.—Plan of Chanoine dam. B, horse; C, prop; D, hurter; E, slide; F, sill; G, trip-bar; K K, pillows. Dotted rectangles show position of panels when down.

end of which rests against a shoulder or *hurter*. The panel, the horse, and the prop, taken together, are called a *wicket*. The part of the panel above the axis of oscillation is called

the *chase*, the part below is called the *breech*. The lower end of the breech rests against a sill.

The axis of oscillation of the wickets of the pass was formerly placed at five-twelfths or less of the length of the panel from the bottom, but the present practice is to place it at the middle of the panel. The axis of oscillation of the wickets of the weir is placed but little above the centre of pressure,

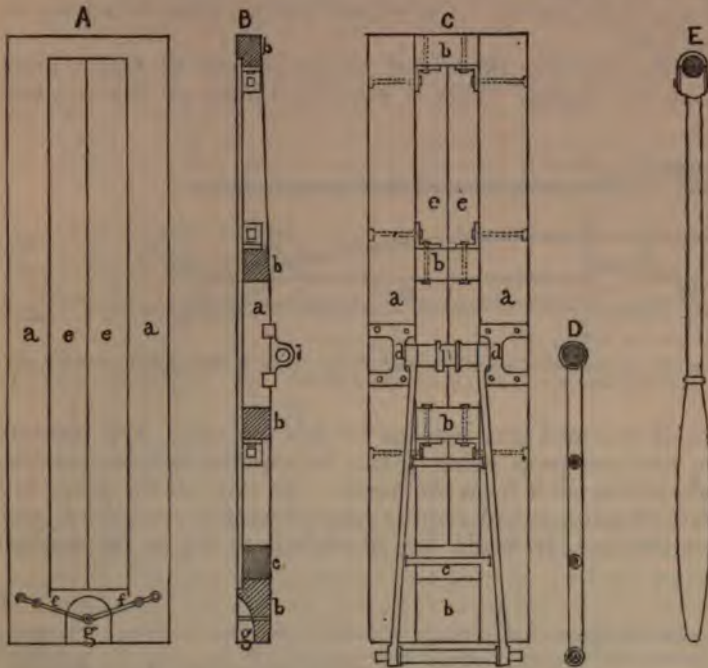

Fig. 264.—A, front view; B, longitudinal section; C, rear view of panel. C also shows horse attached. *a a*, stiles; *b b*, rails; *c*, iron counterpoise; *d*, journal-boxes for head of horse; *e e*, planks; *f f*, bail; *g*, hollow; D, section of horse; E, side view of prop.

so that they may swing spontaneously if the water rises high enough. The wickets of the pass should never swing. The face of the panel makes an angle of  $20^{\circ}$  up-stream, with the vertical line let fall from the centre of oscillation. The prop makes an angle of  $53^{\circ}$  down-stream, and the horse  $5^{\circ}$  down-stream from the same line. In a dam now building in France the inclination of the horse is made up-stream instead of down-stream. This lessens the pull on the horse and the thrust on the prop.

Beyond the hurter is placed the slide. In front of the hurter is the trip-bar, with its guides, rollers, and hooks, the uses of these parts being explained in the manœuvres.

858. The manœuvres of this dam are three: to lower, to raise, and to swing. The wicket is up when the prop rests against the hurter and the foot of the panel against the sill. If, while the wicket is up, the breech be raised so as to let the water pass out both under and over the panel, the latter is said to be *swung*. The wicket is down when it is lying on the floor.

859. To lower the wicket the prop must be drawn away from the hurter. This is done by means of the trip-bar,

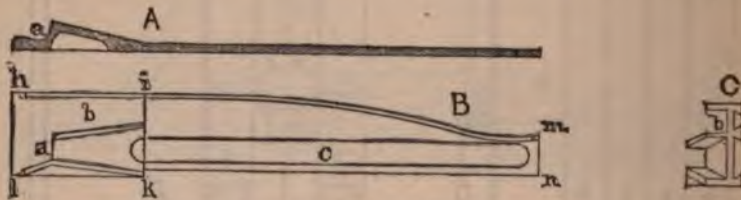

Fig. 265.—A, longitudinal section; B, plan; C, end view of hurter and slide; *h i k l*, hurter; *m n k*, slide; *a*, prop seat; *b*, passage; *c*, groove.

which is armed with catches for this purpose. The pressure on any one prop being great, it requires a corresponding effort to move it from the hurter. To start all the props in a dam at once would require very powerful machinery, and, furthermore, it would be ill-advised to do so on account

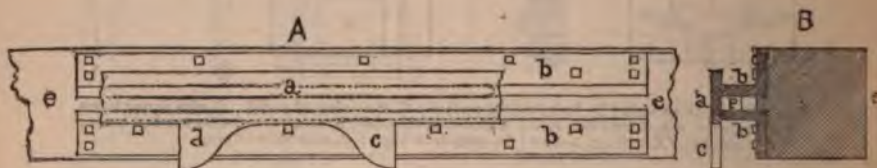

Fig. 266.—A, plan; B, section of trip-bar, guides, and sill; *a*, trip-bar; *b b*, guides; *c*, catch; *d*, counter-catch; *e*, sill; *p*, prisoner.

of letting the entire mass of water in the pool rush out at once, with the risk of doing damage in the pool below. To obviate these difficulties the catches are so arranged on the trip-bar that when the first prop is removed from its hurter the second catch is just beginning to start the second prop, and so on until six or eight wickets have been let down. A certain

part of the water in the pool having now been drawn off, the wickets may be let down by twos and even by threes or fours at the end of the manœuvre. To facilitate the starting of the props the hurters are made with a slight angle down-stream. This angle is of  $3^{\circ}$ , and is called the *escape angle*. The bottom of the prop-seat has a slope downward toward the passage, this slope being called the *escape slope*. To prevent the prop from being displaced by any accident the trip-bar is provided with counter-catches which are evenly spaced so as to be alongside of all the props at once. The trip-bar is made to run straight by means of *guides*. These are generally a pair of L irons placed near together and parallel, the ends having a slight flare. On the bottom of the trip-bar is a projecting stud that moves between the guides and is called the *prisoner*. For greater ease in moving it to and fro the

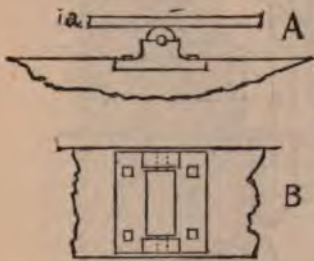

Fig. 207.—A, side view, and B, plan of roller and sill; a, trip-bar resting on roller.

trip-bar rests on rollers placed sufficiently near together to prevent sagging. Motion is communicated to the trip-bar by means of a capstan designed for this purpose. At the end of the trip-bar in the pier or abutment is a rack, into which is geared a pinion attached to the bottom of a shaft, which reaches to the top of the pier. By making this shaft revolve in one way the bar is run out, and in the other way it is run in. An indicator shows the position of the trip-bar. It should always be kept well run in, so as to avoid accidents, and only moved out when it is desired to throw down entirely some of the wickets. Strong hooks projecting over the bar are fastened to its sill to prevent it from being thrown upward and displaced. The slide has a curved guard at its side so constructed as to cause the axis of the prop, when down, to come in line with the middle of the wicket. In the bottom of the slide is a groove, so that when raising a wicket the end of the prop will travel in the right path, until it drops against the hurter.

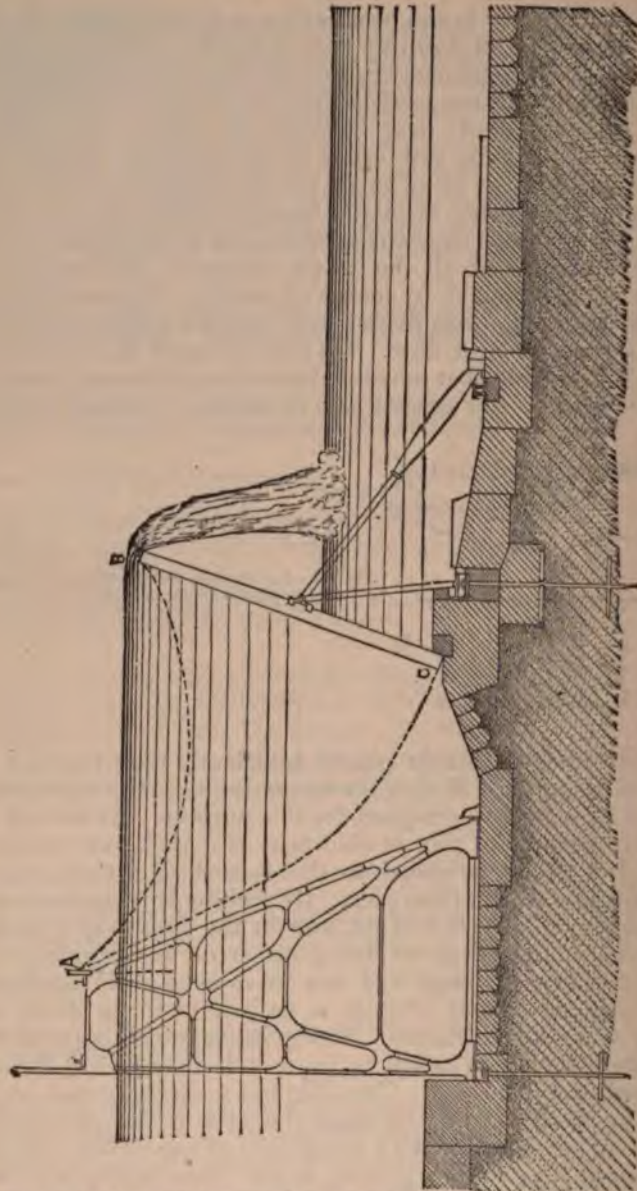

Fig. 268.—Section of Port-a-l'Anglais dam on the Seine near Paris. Poirée trestles used to make a service bridge on the up-stream of wickets, for the purpose of performing manoeuvres more readily. A B and A C, manoeuvring chains from bridge to top and bottom of panel.

860. The wicket is raised by catching the bail at the bottom with a long-handled hook to which a rope or chain is attached. The line is pulled in by means of a windlass mounted either on a service bridge just above the wickets, or else on a boat designed for this service. As the line is drawn in, the end of the breech is raised first, thus presenting the smallest surface of the panel to the current; afterward the entire wicket is drawn forward until the prop drops into its seat at the front of the hurter. In order not to increase the resistance of the current too much at the end of the manœuvre, the wickets, as they are drawn up, are generally left swung. After they are all brought to this position the breeches are pushed down until the current strikes them, after which they are gently lowered to place. This manœuvre can only be performed with the bridge. When the boat is used the wickets have to set up as soon as they are raised. To assist the panel in coming to its upright position, a cast-iron counterpoise is attached to the breech.

861. In some cases wickets have been built with the axis of oscillation very nearly at the centre of pressure of the water, the object of this arrangement being to allow the panel to be swung by the pressure of the water rising more than a certain permitted height above the normal level of the pool. This plan worked successfully so far as opening the wickets was concerned, but when the water returned to the normal level the panels did not retake their position as it was expected they would. Many means for overcoming this difficulty have been devised, but none have proved satisfactory. It is now admitted that self-regulating wickets for the weirs do not work, and the latest practice is to build a light service bridge above them and manœuvre them by means of two chains extending from the bridge to the top and bottom of the panel. By means of these chains the desired amount of swing can be given.

862. The trip-bar is the weakest feature of the Chanoine dam. The machinery to move it is more or less complicated, it is liable to get out of order, and if, for any reason, one wicket should refuse to go down, the movement of the bar is stopped and the rest of the dam has to remain standing. By an arrangement of the hurter lately made the trip-bar is done away with altogether. The hurter has two steps, the higher, which is the prop-seat, is made with a sort of pocket for the end of the prop to rest in, the lower has its down-stream face vertical and making a very acute angle with the axis of the passage. The wicket is raised as in the ordinary system. The

breech-chain is pulled in until the prop falls into its seat. Warning is given of its having reached its place either by the noise of its dropping into the upper step or by the arrival of a marked link at the windlass. The panel is righted by letting out the breech-chain slowly until the sill is touched. To lower the wicket it is first brought to the swing by raising the breech. The motion is continued until the head of the

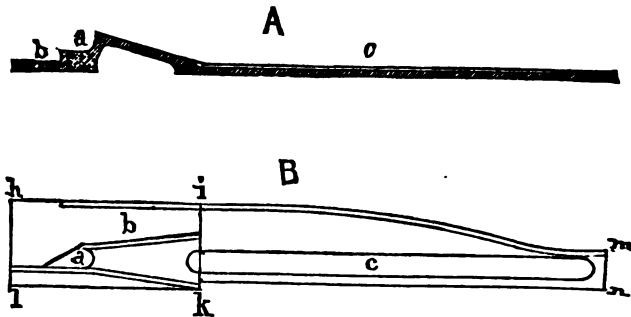

Fig. 260.—A, longitudinal section; B, plan of Pasquean's double-seated hurter and slide; a, prop seat; b, passage; c, groove; A i k l, hurter; i m n k, slide.

horse is pulled up-stream, dragging with it the prop, which then falls down the second step and is thus left without support. The inclined face of this second step directs the prop toward the passage of the hurter. The weight of the system carries it down, and the chain being paid out, slowly prevents it from falling to the bottom with a shock. By means of this device each wicket is entirely isolated and independent. One of them failing to act will not cause any interference with the other, and, even in the event of any difficulty, the absence of counter-catches makes it easy to knock down a prop from a skiff below the dam. A further advantage is that the navigable pass can be made of any width desired, which was not the case with the old trip-bar, because there the width of the pass could not exceed twice the length of a bar, one being manœuvred at each end.

**863. Boulé Dam.**—If an ordinary Poirée dam be stripped of its needles, and in their place there be used sliding gates made of a certain number of planks laid horizontally and firmly fastened together, these gates being slightly shorter than the distance between the axles of the trestles, and having each end resting on a trestle, we shall have the Boulé dam.

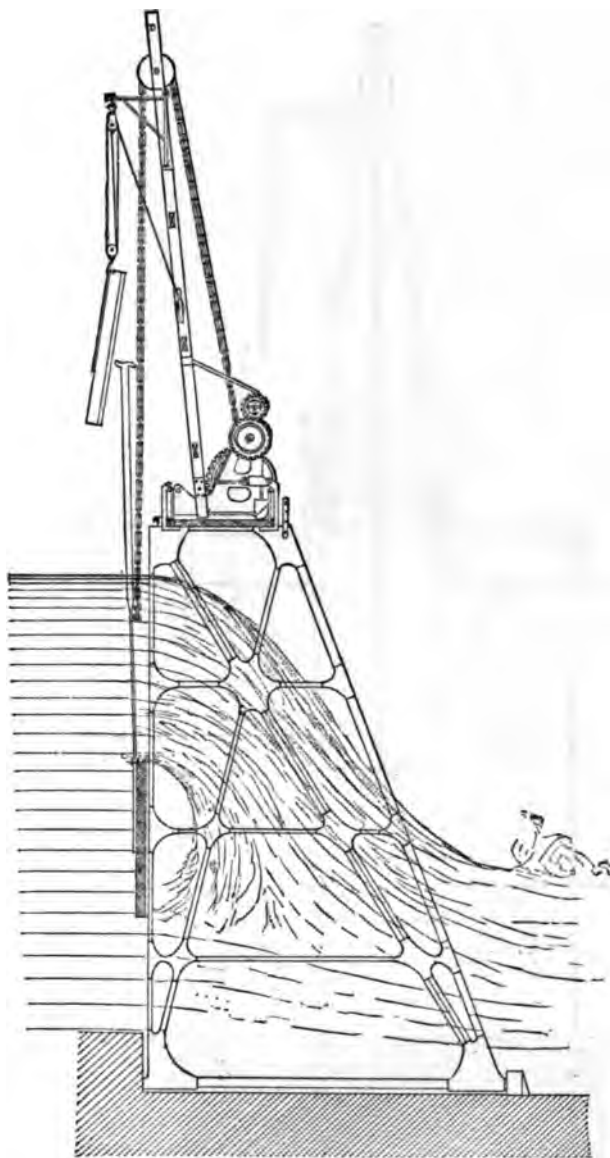

Fig. 270.—Section of Boulé dam, showing manner of raising a gate. The derrick runs on the connecting bars of the trestles.



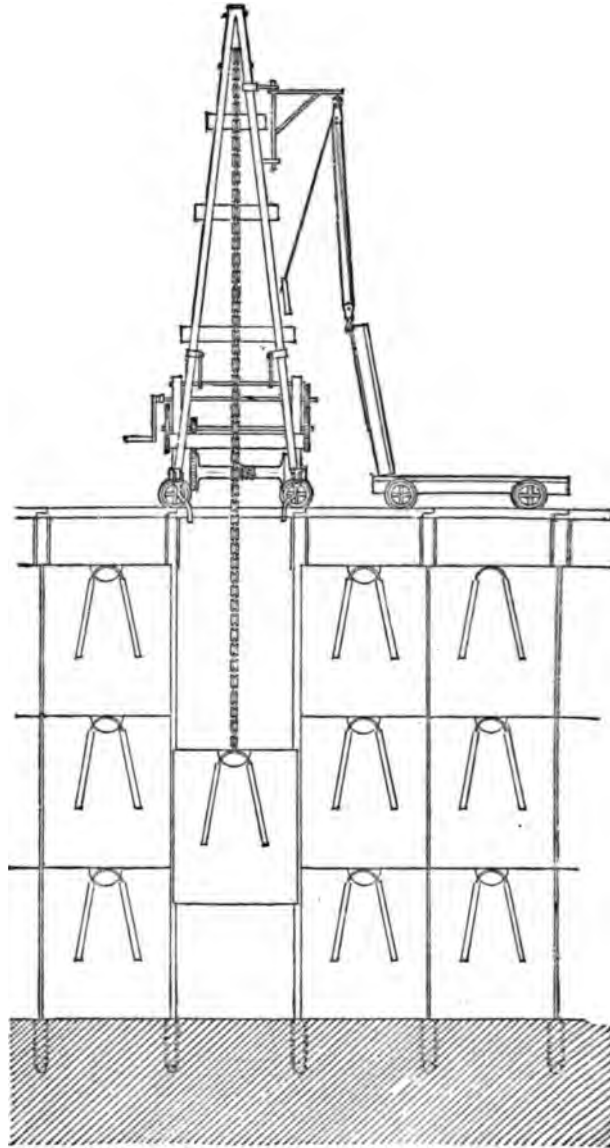

Fig. 271.—Front view of Boulé dam.

The gates are made of four or five planks laid side by side. The thickness of the planks must be proportionate to the distance of the trestles apart and to the head of water. T-irons are bolted to the back of the gate. They answer a double purpose: 1st, they keep the planks from separating and strengthen them; 2d, they are guides to prevent the gates moving sideways and being displaced. A better arrangement is to place ribs on the trestles to act as guides. At the top of the gate a countersunk handle is attached.

884. The manœuvres are two: 1st, to set the gates in place; 2d, to remove them. The manœuvring apparatus is a small

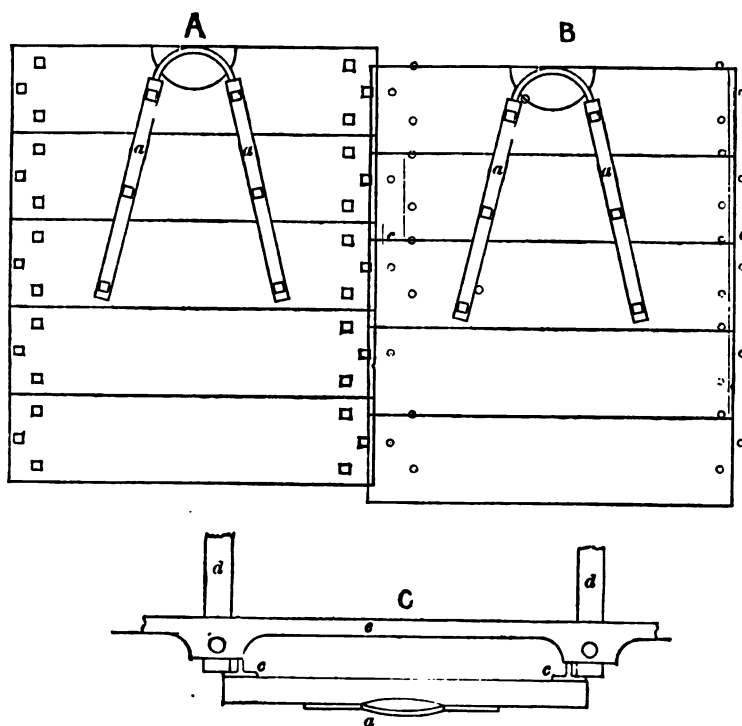

Fig. 272.—A, front view; B, back view; C, plan of Boulé gates; a, a, handle; c, c, T-iron guides; d, d, cap of trestle; e, connecting bar.

derrick that runs on the track formed by the connecting bars of the trestles. To the side of this derrick is attached a little crane as an auxiliary.

The dam being wholly open it is desired to close it. The

trestles are raised exactly as in the Poirée dam. The derrick is run out on the track, followed by a truck carrying three or four gates. The crane picks up a gate from the trunk and swings it around so that the chain of the main derrick can take it. The gate is lowered into place between two trestles, the T-iron guides keeping it in position. The derrick is then pushed on to the next space and another gate is lowered, and so on till a single row has been laid all across the dam. The second row is then laid in the same way as the first, and so on for the third, fourth, or any other row.

To dismantle the dam the operations are performed in reverse order. The top row of gates is removed, then the next below, and so on down.

**865. Bear Trap Gate.**—This style of dam is formed of two plane gates, having their axes of revolution in the floor of the dam. One of them is arranged to fall up-stream and the other down-stream. The one that falls down-stream has its

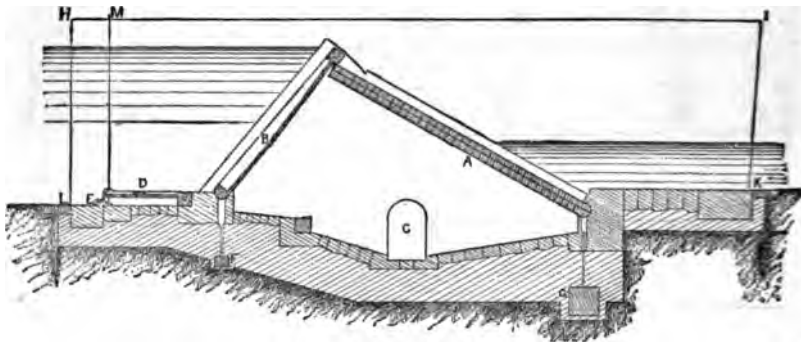

Fig. 273.—Section of bear-trap gate raised. A, lower gate; B, upper gate; C, entrance for water from passage in pier; D, auxiliary gate; E, trigger; E M, trigger rod; F, G, anchorages; H I K L, pier.

axis on the up-stream side, the one that falls up-stream has its axis on the down-stream side. The gate falling down-stream is called the upper gate, the other is called the lower gate. When the dam is down the upper gate projects over the lower. Near the top of the upper gate a bar of wood is fastened to the pier as a stop to the movement of the lower gate. Under the gates a chamber is made in the floor of the dam into which water may be introduced from the upper pool by a lateral conduit. Above the upper gate an auxil-

iliary gate is sometimes placed in order to form a temporary head of water. In the pier of the dam is a passage-way for water. This passage runs from the upper to the lower pool, with an entrance at its side to the chamber under the gates. A valve is placed at each end of the passage, and communication can thus be made between the chamber and either the upper or lower pool.

866. Suppose the dam to be down and it be required to raise it. The valves in the pier are thus arranged: the one leading from the upper pool is opened and the other is closed. Communication is thus made between the upper pool and the chamber. If an auxiliary gate is used it is then released by raising the trigger that holds it down. This gate is hinged on the down-stream side; its buoyancy causes it to rise to a

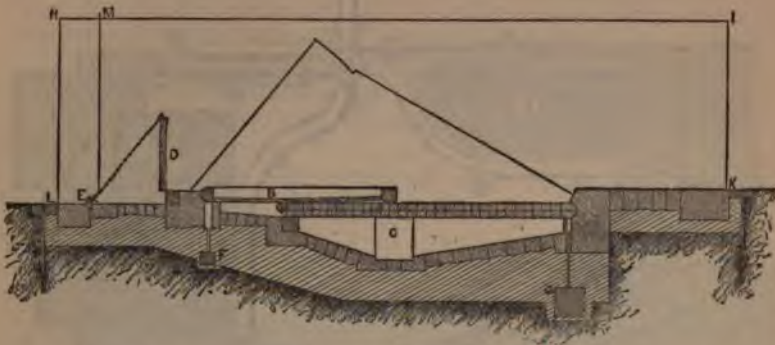

Fig. 274.—Section of bear-trap gate down. A, lower gate; B, upper gate; C, entrance for water from passage in pier; D, auxiliary gate; E, trigger; E M, trigger rod; F and G, anchorages; H I K L, pier.

certain degree and the current then strikes it on the under side and raises it to a vertical position; it thus forms a temporary dam. The water rising in the upper pool exerts a pressure on the under side of the lower gate and gradually raises it. This gate, in rising, forces up the other. When the lower gate reaches the stop placed on the under side of the upper the motion ceases. The gates remain up so long as the communication is kept up between the upper pool and the chamber. When the gates are up the auxiliary gate is returned to its place and confined.

When the dam is to be lowered the position of the valves is reversed, the chamber is cut off from the upper pool and

communication established with the lower. The water in the chamber runs out into the lower pool and the gates fall under their own weight and that of the water resting on them.

**867. Desfontaines Dam.**—This dam is composed of a number of independent sections, each turning on a horizontal axis placed at its middle. The upper half is the *wicket* proper; its function is to form the pool; the lower half is

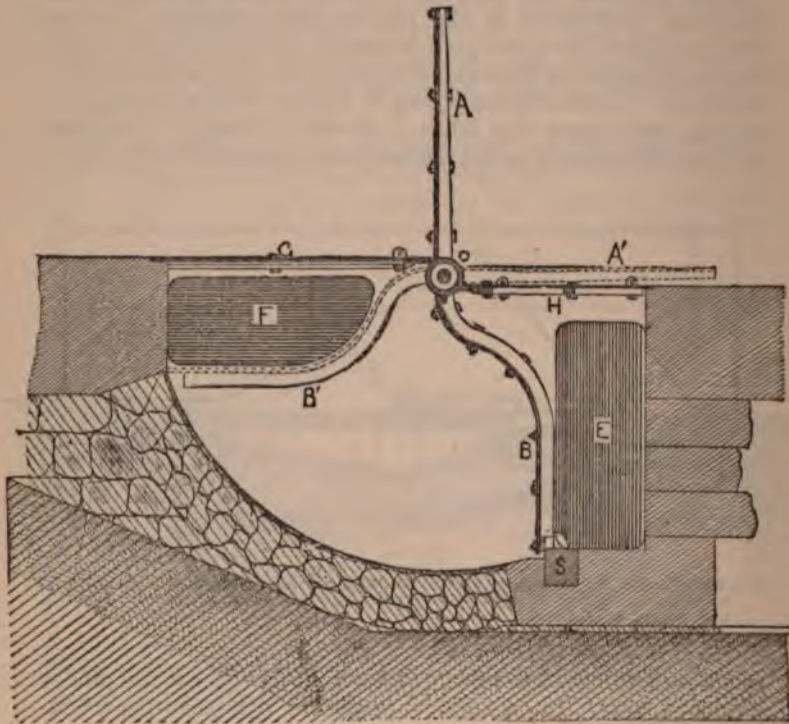

Fig. 275.—Section of Desfontaines dam. A, wicket, and B, counter-wicket, when dam is raised; E, emptying opening in diaphragm; F, filling opening in diaphragm; G, H, covering plates; S, sill; A', B', position of wicket and counter-wicket when down.

called the *counter-wicket*, and its function is merely to move the wicket. These sections are about five feet long, and when in position are so set that their axes of revolution are in the same straight line. The counter-wickets are set in a masonry cavity that runs the entire length of the dam. This

cavity is a quarter of a horizontal cylinder, the axis of which coincides with that of the wickets. The plane sides of this quarter cylinder do not pass exactly through its axis; the horizontal one is raised up a little and the vertical one moved a little down-stream, so that each one leaves a vacant space between it and the counter-wicket when the latter is in its extreme positions. The counter-wicket is also somewhat bent, so that the horizontal side of the quarter cylinder need not be raised too high, and thus cover a part of the wicket. Finally the cavity is divided into as many sections as there are wickets; these sections, called drums, are separated by cast-iron diaphragms, on each side of which is a rib of the same shape as the counter-wicket. In each diaphragm are two openings corresponding to the vacant spaces above mentioned. When the dam is closed the counter-wicket rests against a sill at the bottom of the drum, against the rib of the diaphragm on either side, and against a rib on the cast-iron tube that encloses the axle of the wicket.

At each end of the dam is an abutment or a pier. As the arrangements for admitting the water to manœuvre the dam are the same in either case, those of the pier alone will be described.

868. The pier extends beyond the floor of the dam both up- and down-stream. In each end is a vertical well, one

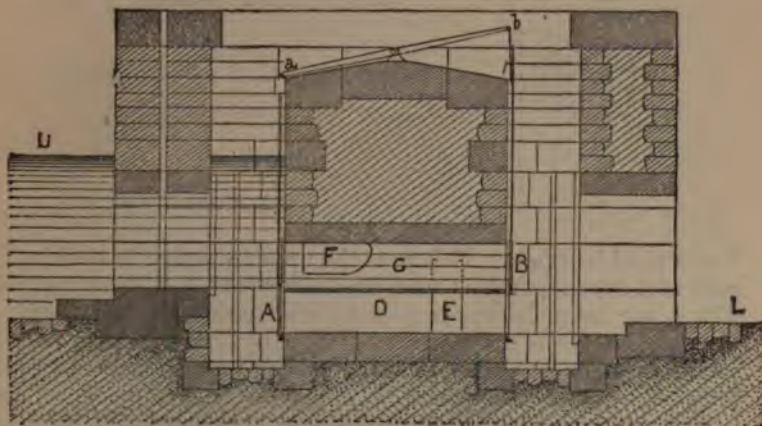

Fig. 276.—Section of pier of Desfontaines dam, with the valves arranged to raise the dam. U, upper pool; L, lower pool; A B, valves; C, top passage; D, bottom passage; E, emptying opening in diaphragm; F, filling opening in diaphragm; a b, oscillating beam to make both valves move in opposite directions at the same time.

being in communication with the upper pool and the other with the lower. The two wells are connected by a rectangular gallery, which is divided in halves by means of a cast-iron plate placed horizontally in the gallery. At each end of the gallery is a valve, just large enough to cover either half, and so arranged that the up-stream end of one passage and the down-stream end of the other shall be open or closed at the same time. The upper passage leads to the openings on the up-stream side of the counter-wickets, and the lower passage to the openings in the down-stream side. A balance-beam on top of the pier gives the motion to the valves.

869. If it be desired to close the dam, the operation is thus performed. The valves are so arranged that the up-stream end of the upper passage and the down-stream end of the

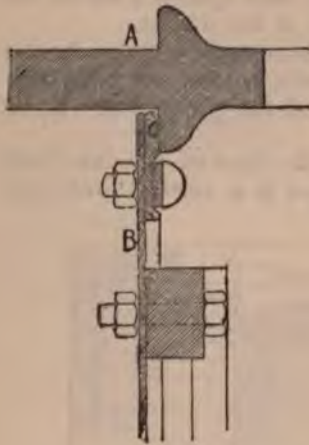

Fig. 277.—Arrangement of side of counter-wicket. A, diaphragm with rib; B, face of counter-wicket; C, India-rubber backing.

lower shall be open. This puts the upper passage in connection with the upper pool and the lower with the lower pool. The water from the upper pool enters the nearest drum, and pressing on the counter-wicket gradually forces it down and thus raises the wicket. Passing in this way from drum to drum the wickets are raised.

When the dam is raised the leakage is reduced to a minimum by having India-rubber strips on all of the edges of the counter-wicket, and this rubber being jammed against the sill and the ribs by the pressure of the water in front, prevents

any great amount of water from passing. The space behind the counter-wicket being in communication with the lower pool prevents the water that leaks through from rising above this level.

To lower the dam the position of the valves is reversed. The pressure of the upper pool is now brought to bear against

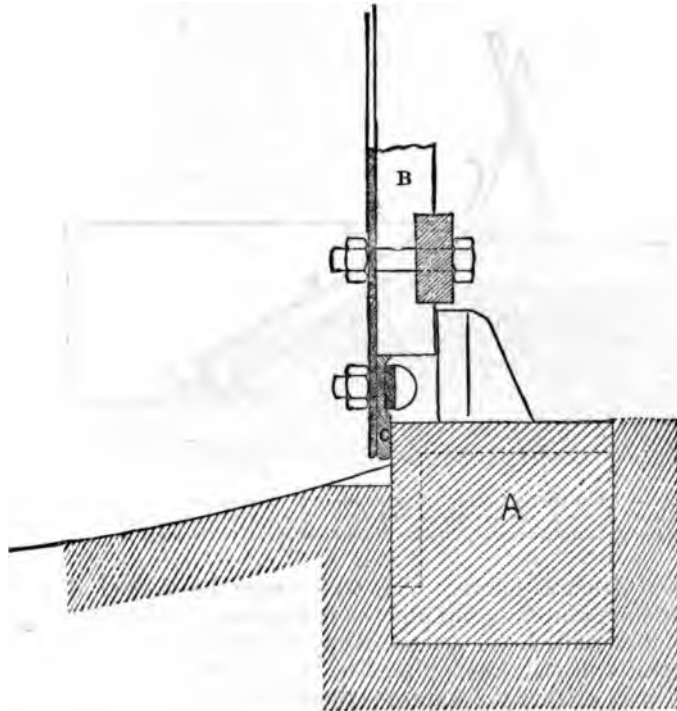

Fig. 278.—Arrangement of bottom of counter-wicket. A, sill; B, counter-wicket; C, India-rubber backing.

the back of the counter-wicket, which, therefore, is forced upward at the same time that the wicket proper is forced down by the direct pressure of the water in the upper pool.

870. In case that sand or gravel, or anything of that sort, should find its way into the drums, the latter are easily washed out by opening the up-stream side of the drums at one end of the dam into the upper pool, and at the other into the lower.



This will cause the water to rush violently through and remove all rubbish.

**871. Girard Dam.**—This dam is composed of a series of shutters or gates, movable about their bottom edge, and actuated by means of large hydraulic jacks. Each shutter has its own jack and is therefore independent of the rest. To each jack is connected a pipe through which water may be

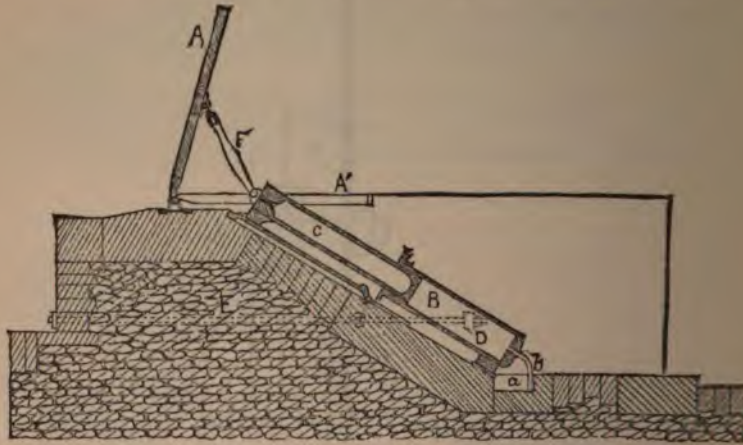

Fig. 279.—Section of Girard dam. A, shutter-up; A', shutter-down; B, hydraulic jack; C, piston; D, lug on side by which it is fastened to masonry by rod E; F, connecting rod; a, trough to receive pipes b, through which water is sent to the jacks.

forced from a pump. The water may be forced directly from the pump into the pipe, or it may be sent through an air-chamber, called the accumulator, the latter being the mode generally used. Each pipe has in the pump-house a three-way cock, so that the water may enter the jacks either directly from the pump or after first passing through the accumulator; or else it can be discharged and the jack emptied. The jack is placed on the down-stream side of the shutters, and forces them up against the current. When the dam is up it is only necessary to shut the water off in the pipe in order to hold it in place. If the cock be turned to let the water escape, the shutter will be forced down by the pressure of the pool. By a proper arrangement of the cocks we may have any motion of the shutters that we choose. One may go up and another come down, while a third is standing all the way up and a fourth is held in any intermediate position.

872. The six systems just given are those best known. Others have been proposed, but they have not been adopted in actual construction. Of these latter we have the Krantz, the Cuvinot, and the Carro.

873. The *Krantz system* consists of a sheet-iron ponton hinged at its upper down-stream corner, and moved by letting water into a chamber underneath it to raise it, and letting the water out to lower it. To the upper up-stream corner of the ponton is fastened a panel similar to that in the Chanoine system. This panel, when the dam is down, lies on top of the ponton, and when the dam is up it is held by the ponton in a position similar to the one it has in the Chanoine dam.

874. The *Cuvinot system* is a modification of the Desfontaines. The wicket and counter-wicket are independent, and revolve on separate axes. The axis of the counter-wicket coincides with that of the cavity. The axis of the wicket is placed up-stream from, and a little higher than that of the counter-wicket. The arms of the counter-wicket, when prolonged beyond the axis, are bent down-stream, so that the two parts of the arms make an angle of 160 degrees with each other. These arms have rollers at the end, and, as the counter-wicket revolves, raise up the wicket which rests upon them.

875. The *Carro system* is a modification of the bear-trap. In it the two gates are hinged together at the top, the bottoms of both gates sliding along the floor. The lower gate is held down by links.

876. The *Caméré system* is one of very recent date; it has been adopted and is to be used in one of the dams now building in France. It consists of a number of narrow slips of wood joined together by articulations in such a way that they may be rolled up into a bundle. The bundle, when unrolled and hung up by one end, forms a curtain, the sides of which, when in place, rest against uprights suspended from an overhead bridge. The curtain is rolled up, like an awning, by means of a line on each side. The curtains may also be used in connection with the Poirée trestles, the latter taking the place of the suspended uprights. This system has not yet been tested on a large scale. The inventor claims, however, that it is especially valuable for great depths and lifts.

877. In the United States some efforts have been made towards the invention of movable dams, but none have yet been built for use on any but a small scale. They have not served

for any purpose connected with navigation. . The bear-trap is an American work, and invention has been mainly confined to modifications thereof, except in the case of the *Brunot gate*. This last differs from the Krantz system in two points: 1st, it has no panel; 2d, the ponton is hinged at the upper up-stream corner, and itself forms the dam.

878. These various forms of dam lend themselves better to some purposes than to others. The Poirée, Chanoine, and Boulé systems are well adapted to service in either the navigable pass or the weirs. The Desfontaines and Girard systems, on account of their high masonry floors, are applicable only to weirs. The bear-trap is only good for small widths, and within limits of thirty-five to forty feet it may work well for either great or small lifts.

879. When the obstruction in a river cannot be overcome by any of the preceding means, as, for example, in those considerable descents in the bed known as rapids, where the water acquires a velocity so great that a boat can neither ascend nor descend with safety, resort must be had to a canal for the purpose of uniting its navigable parts above and below the obstruction.

The general direction of the canal will be parallel to the bed of the river. In some cases it may occupy a part of the bed by forming a dike in the bed parallel to the bank, and sufficiently far from it to give the requisite width to the canal. Whatever position the canal may occupy, every precaution should be taken to secure it from damage by freshets.

880. A lock will usually be necessary at each extremity of the canal where it joins the river. The positions for the extreme locks should be carefully chosen, so that the boats can at all times enter them with ease and safety. The locks should be secured by guard gates and other suitable means from freshets; and if they are liable to be obstructed by deposits, arrangements should be made for their removal either by a chase of water or by machinery.

If the river should not present a sufficient depth of water at all seasons for entering the canal from it, a dam will be required at some point near the lock to obtain the requisite depth.

It may be advisable in some cases, instead of placing the extreme locks at the outlets of the canal to the river, to form a capacious basin at each extremity of the canal between the lock and river, where the boats can lie in safety. The outlets from the basins to the rivers may either be left open at all

times, or else guard gates may be placed at them to shut off the water during freshets.

881. The French have done more for the improvement of their water-ways than almost any other people. All the systems mentioned here, except the bear-trap and the Brunot, are of French origin. The engineering literature of France contains a vast amount of interesting matter on river improvements. Much of this is to be found in the *Annales des Ponts et Chaussées*, in the shape of various exhaustive articles on different subjects. The *Cours de Navigation Intérieur*, by M. de Lagrené, contains the best practice up to the time in which it was written, but since then the subject of movable dams especially has made great strides in advance.

## CHAPTER X.

## SEACOAST IMPROVEMENTS.

882. THE following subdivisions may be made of the works belonging to this class of improvements: 1st. Artificial Roadsteads. 2d. The works required for natural and artificial Harbors. 3d. The works for the protection of the seacoast against the action of the sea.

883. Before adopting any definitive plan for the improvement of the seacoast at any point, the action of the tides, currents, and waves at that point must be ascertained.

884. The theory of tides is well understood; their rise and duration, caused by the attraction of the sun and moon, are also dependent on the strength and direction of the wind, and the conformation of the shore. Along our own seaboard, the highest tides vary greatly between the most southern and northern parts. At Eastport, Me., the highest tides, when not affected by the wind, vary between twenty-five and thirty feet above the ordinary low water. At Boston they rise from eleven to twelve feet above the same point, under similar circumstances; and from New York, following the line of the seaboard to Florida, they seldom rise above five feet.

885. Currents are principally caused by the tides, assisted, in some cases, by the wind. The theory of their action is simple. From the main current, which sweeps along the coast, secondary currents proceed into the *bays*, or indentations, in a line more or less direct, until they strike some point of the shore, from which they are deflected, and frequently separate into several others, the main branch following the general direction which it had when it struck the shore, and the others not unfrequently taking an opposite direction, forming what are termed *counter currents*, and, at points where the opposite currents meet, that rotary motion of the water known as *whirlpools*. The action of currents on the coast is to wear it away at those points against which they directly impinge, and to transport the *débris* to other points, thus forming, and sometimes removing, natural obstructions to navigation. These continual changes, caused by currents, make it extremely difficult to foresee their effects,

and to foretell the consequences which will arise from any change in the direction, or the intensity of a current, occasioned by artificial obstacles.

886. A good theory of waves, which shall satisfactorily explain all their phenomena, is still a desideratum in science. It is known that they are produced by winds acting on the surface of the sea; but how far this action extends below the surface and what are its effects at various depths, are questions that remain to be answered. The most commonly received theory is, that a wave is a simple oscillation of the water, in which each particle rises and falls, in a vertical line, a certain distance during each oscillation, without receiving any motion of translation in a horizontal direction. It has been objected to this theory that it fails to explain many phenomena observed in connection with waves.

In a recent French work on this subject, its author, Colonel Emy, an engineer of high standing, combats the received theory; and contends that the particles of water receive also a motion of translation horizontally, which, with that of ascension, causes the particles to assume an orbicular motion, each particle describing an orbit, which he supposes to be elliptical. He farther contends, that in this manner the particles at the surface communicate their motion to those just below them, and these again to the next, and so on downward, the intensity decreasing from the surface, without, however, becoming insensible at even very considerable depths; and that, in this way, owing to the reaction from the bottom, an immense volume of water is propelled along the bottom itself, with a motion of translation so powerful as to overthrow obstacles of the greatest strength if directly opposed to it. From this he argues that walls built to resist the shock of the waves should receive a very great batir at the base, and that this batir should be gradually decreased upward, until, towards the top, the wall should project over, thus presenting a concave surface at top to throw the water back. By adopting this form, he contends that the mass of water, which is rolled forward, as it were, on the bottom, when it strikes the face of the wall, will ascend along it, and thus gradually lose its momentum. These views of Colonel Emy have been attacked by other engineers, who have had opportunities to observe the same phenomena, on the ground that they are not supported by facts; and the question still remains undecided. It is certain, from experiments made by the author quoted upon walls of the form here described, that they seem to answer fully their intended purpose.

887. **Roadsteads.** The term *roadstead* is applied to an indentation of the coast, where vessels may ride securely at anchor under all circumstances of weather. If the indentation is covered by natural projections of the land, or *capes*, from the action of the winds and waves, it is said to be *land-locked*; in the contrary case, it is termed an *open* roadstead.

The anchorage of open roadsteads is often insecure, owing to violent winds setting into them from the sea, and occasioning high waves, which are very straining to the moorings. The remedy applied in this case is to place an obstruction near the entrance of the roadstead, to break the force of the waves from the sea. These obstructions, termed *breakwaters*, are artificial islands of greater or less extent, and of variable form, according to the nature of the case, made by throwing heavy blocks of stone into the sea, and allowing them to take their own bed.

The first great work of this kind undertaken in modern times, was the one at Cherbourg in France, to cover the roadstead in front of that town. After some trials to break the effects of the waves on the roadstead by placing large conical-shaped structures of timber filled with stones across it, which resulted in failure, as these vessels were completely destroyed by subsequent storms, the plan was adopted of forming a breakwater by throwing in loose blocks of stone, and allowing the mass to assume the form produced by the action of the waves upon its surface. The subsequent experience of many years, during which this work has been exposed to the most violent tempests, has shown that the action of the sea on the exposed surface is not very sensible at this locality at a depth of about 20 feet below the water level of the lowest tides, as the blocks of stone forming this part of the breakwater, some of which do not average over 40 lbs. in weight, have not been displaced from the slope the mass first assumed, which was somewhat less than one perpendicular to one base. From this point upwards, and particularly between the levels of high and low water, the action of the waves has been very powerful at times, during violent gales, displacing blocks of several tons weight, throwing them over the top of the breakwater upon the slope towards the shore. Wherever this part of the surface has been exposed the blocks of stone have been gradually worn down by the action of the waves, and the slope has become less and less steep, from year to year, until finally the surface assumed a slightly concave slope, which, at some points, was as great as ten base to one perpendicular.

The experience acquired at this work has conclusively shown that breakwaters, formed of the heaviest blocks of loose stone, are always liable to damage in heavy gales when the sea breaks over them, and that the only means of securing them is by covering the exposed surface with a facing of heavy blocks of hammered stone carefully set in hydraulic cement.

As the Cherbourg breakwater is intended also as a military construction, for the protection of the roadstead against an enemy's fleet, the cross section shown (in Fig. 248) has been adopted for it. Profiting by the experience of many years' observation, it was decided to construct the work that forms the cannon battery of solid masonry laid on a thick and broad bed of beton. The top surface of the breakwater is covered with heavy loose blocks of stone, and the foot of the wall on the face is protected by large blocks of artificial stone formed of beton. The top of the battery is about 12 feet above the highest water level.



Fig. 248—Represents a section of the Cherbourg breakwater.  
A, mass of stone.  
B, battery of masonry.

The next work of the kind was built to cover the roadstead of Plymouth in England. Its cross section was, at first, made with an interior slope of one and a half base to one perpendicular, and an exterior slope of only three base to one perpendicular; but from the damage it sustained in the severe tempests in the winter of 1816-17, it is thought that its exterior slope was too abrupt.

A work of the same kind is still in process of construction on our coast, off the mouth of the Delaware. The same cross section has been adopted for it as in the one at Cherbourg.

All of these works were made in the same way, discharging the stone on the spot, from vessels, and allowing it to take its own bed, except for the facing, where, when practicable, the blocks were carefully laid, so as to present a uniform surface to the waves. The interior of the mass, in each



case, has been formed of stone in small blocks, and the facing of very large blocks. It is thought, however, that it would be more prudent to form the whole of large blocks, because, were the exterior to suffer damage, and experience shows that the heaviest blocks yet used have at times been displaced by the shock of the waves, the interior would still present a great obstacle.

From the foregoing details, respecting the cross sections of breakwaters, which from experiment have been found to answer, the proper form and dimensions of the cross section in similar cases may be arranged. As to the plan of such works, it must depend on the locality. The position of the breakwater should be chosen with regard to the direction of the heaviest swells from the sea into the roadstead,—the action of the current, and that of waves. The part of the roadstead which it covers should afford a proper depth of water, and secure anchorage for vessels of the largest class, during the most severe storms; and vessels should be able to double the breakwater under all circumstances of wind and tide. Such a position should, moreover, be chosen that there will be no liability to obstructions being formed within the roadstead, or at any of its outlets, from the change in the current which may be made by the breakwater.

888. The difficulty of obtaining very heavy blocks of stone, as well as their great cost, has led to the suggestion of substituting for them blocks of artificial stone, formed of concrete, which can be made of any shape and size desirable. This plan has been tried with success in several instances, particularly in a jetty or mole, at Algiers, constructed by the French government. The beton for a portion of this work was placed in large boxes, the sides of which were of wood, shaped at bottom to correspond to the irregularities of the bottom on which the beton was to be spread. The bottom of the box was made of strong canvas tarred. These boxes were first sunk in the position for which they were constructed, and then filled with the beton.

889. **Harbors.** The term *harbor* is applied to a secure anchorage of a more limited capacity than a roadstead, and therefore offering a safer refuge during boisterous weather. Harbors are either *natural* or *artificial*.

890. An artificial harbor is usually formed by enclosing a space on the coast between two arms, or dikes of stone, or of wood, termed *jetties*, which project into the sea from the shore, in such a way as to cover the harbor from the action of the wind and waves.

891. The plan of each jetty is curved, and the space enclosed by the two will depend on the number of vessels which it may be supposed will be in the harbor at the same time. The distance between the ends, or *leads*, of the jetties which forms the mouth of the harbor, will also depend on local circumstances; it should seldom be less than one hundred yards, and generally need not be more than five hundred. There are certain winds at every point of a coast which are more unfavorable than others to vessels entering and quitting the harbor, and to the tranquillity of its water. One of the jetties should, on this account, be longer than the other, and be so placed that it will both break the force of the heaviest swells from the sea into the mouth of the harbor, and facilitate the ingress and egress of vessels, by preventing them from being driven by the winds on the other jetty, just as they are entering or quitting the mouth.

892. The cross section and construction of a stone jetty differ in nothing from those of a breakwater, except that the jetty is usually wider on top, thirty feet being allowed, as it serves for a wharf in unloading vessels. The head of the jetty is usually made circular, and considerably broader than the other parts, as it, in some instances, receives a lighthouse, and a battery of cannon. It should be made with great care, of large blocks of stone, well united by iron or copper cramps, and the exterior courses should moreover be protected by fender beams of heavy timber to receive the shock of floating bodies.

893. Wooden jetties are formed of an open framework of heavy timber, the sides of which are covered on the interior by a strong sheeting of thick plank. Each rib of the frame (Fig. 249) consists of two inclined pieces, which form the sides—of an upright centre piece,—and of horizontal clamping pieces, which are notched and bolted in pairs on the inclined and upright pieces; the inclined pieces are farther strengthened by struts, which abut against them and the upright. The ribs are connected by large string-pieces, laid horizontally, which are notched and bolted on the inclined pieces, the uprights, and the clamping pieces, at their points of junction. The foundation, on which this framework rests, consists usually of three rows of large piles driven under the foot of the inclined pieces and the uprights. The rows of piles are firmly connected by cross and longitudinal beams notched and bolted on them; and they are, moreover, firmly united to the framework in a similar manner. The interior sheeting does not, in all cases, extend the entire length of

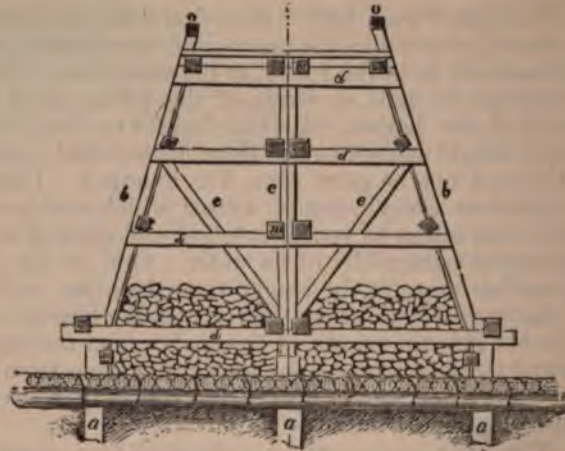

Fig. 249—Represents a cross section of a wooden jetty. *a*, foundation piles. *b*, inclined side pieces. *c*, middle upright. *d*, cross pieces bolted in pairs. *s*, struts. *m*, longitudinal pieces bolted in pairs. *o*, parapet.

the sides, but open spaces, termed *clear-ways*, are often left, to give a free passage and spread to the waves confined between the jetties, for the purpose of forming smooth water in the channel. If the jetties are covered at their back with earth, the clear-ways receive the form of inclined planes.

The foundation of the jetties requires particular care, especially when the channel between them is very narrow. Loose stone thrown around the piles is the ordinary construction used for this purpose; and, if it be deemed necessary, the bottom of the entire channel may be protected by an apron of brush and loose stone.

The top of the jetties is covered with a flooring of thick plank, which serves as a wharf. A strong hand-railing should be placed on each side of the flooring as a protection against accidents. The sides of jetties have been variously inclined; the more usual inclination varies between three and four perpendicular to one base.

894. Jetties are sometimes built out to form a passage to a natural harbor, which is either very much exposed, or subject to bars at its mouth. By narrowing the passage to the harbor between the jetties, great velocity is given to the current caused by the tide, and this alone will free the greater part of the channel from deposits. But at the head of the jetties a bar will, in almost every case, be found to accumulate, from the current alongshore, which is broken

by the jetties, and from the diminished velocity of the ebbing tides at this point. To remove these bars resort may be had, in localities where they are left nearly dry at low water, to reservoirs, and sluices, arranged with turning gates, like those adverted to for river improvements. The reservoirs are formed by excavating a large basin inshore, at some suitable point from which the collected water can be directed, with its full force, on the bar. The basin will be filled at flood-tide, and when the ebb commences the sluice gates will be kept closed until dead low water, when they should all be opened at once to give a strong water chase.

895. In harbors where vessels cannot be safely and conveniently moored alongside of the quays, large basins, termed *wet-docks*, are formed, in which the water can be kept at a constant level. A wet-dock may be made either by an inshore excavation, or by enclosing a part of the harbor with strong water-tight walls; the first is the more usual plan. The entrance to the basin may be by a simple sluice, closed by ordinary lock gates, or by means of an ordinary lock. With the first method vessels can enter the basin only at high tide; by the last they may be entered or passed out at any period of the tide. The outlet of the lock should be provided with a pair of guard gates, to be shut against very high tides, or in cases of danger from storms.

896. The construction of the locks for basins differs in nothing, in principle, from that pursued in canal locks. The greatest care will necessarily be taken to form a strong mass free from all danger of accidents. The gates of a basin-lock are made convex towards the head of water, to give them more strength to resist the great pressure upon them. They are hung and manœuvred differently from ordinary lock gates; the quoin-post is attached to the side walls in the usual way: but at the foot of the mitre-post an iron or brass roller is attached, which runs on an iron roller way, and thus supports that end of the leaf, relieving the collar of the quoin-post from the strain that would be otherwise thrown on it, besides giving the leaf an easy play. Chains are attached to each mitre-post near the centre of pressure of the water, and the gate is opened, or closed, by means of windlasses to which the other ends of the chains are fastened.

897. The quays of wet-docks are usually built of masonry. Both brick and stone have been used; the facing at least should be of dressed stone. Large fender-beams may be attached to the face of the wall, to prevent it from being brought in contact with the sides of the vessels. The cross

section of quay-walls should be fixed on the same principles as that of other sustaining walls. It might be prudent to add buttresses to the back of the wall to strengthen it against the shocks of the vessels.

898. Quay-walls with us are ordinarily made either by forming a facing of heavy round or square piles driven in juxtaposition, which are connected by horizontal pieces, and secured from the pressure of the earth filled in behind them by land-ties; or, by placing the pieces horizontally upon each other, and securing them by iron bolts. Land-ties are used to counteract the pressure of the earth or rubbish which is thrown in behind them to form the surface of the quay. Another mode of construction, which is found to be strong and durable, is in use in our Eastern seaports. It consists in making a kind of crib-work of large blocks of granite, and filling in with earth and stone rubbish. The bottom course of the crib may be laid on the bed of the river, if it is firm and horizontal; in the contrary case a strong grillage, termed a *cradle*, must be made, and be sunk to receive the stone work. The top of the cradle should be horizontal, and the bottom should receive the same slope as that of the bed, in order that when the stones are laid they may settle horizontally.

899. **Dikes.** To protect the lowlands bordering the ocean from inundations, dikes, constructed of ordinary earth, and faced towards the sea with some material which will resist the action of the current, are usually resorted to.

The Dutch dikes, by means of which a large extent of country has been reclaimed and protected from the sea, are the most remarkable structures of this kind in existence. The cross section of those dikes is of a trapezoidal form, the width at top averaging from four to six feet, the interior slope being the same as the natural slope of the earth, and the exterior slope varying, according to circumstances, between three and twelve base to one perpendicular. The top of the dike, for perfect safety, should be about six feet above the level of the highest spring tides, although, in many places, they are only two or three above this level.

The earth for these dikes is taken from a ditch inshore, between which and the foot of the dike a space of about twenty feet is left which answers for a road. The exterior slope is variously faced, according to the means at hand, and the character of the current and waves at the point. In some cases, a strong straw thatch is put on, and firmly secured by pickets, or other means; in others, a layer of fascines is spread over the thatch, and is strongly picketed to it the ends of the pickets

being allowed to project out about eighteen inches, so that they can receive a wicker-work formed by interlacing them with twigs, the spaces between this wicker-work being filled with broken stone; this forms a very durable and strong facing, which resists not only the action of the current, but, by its elasticity, the shocks of the heaviest waves.

The foot of the exterior slope requires peculiar care for its protection; the shore, for this purpose, is in some places covered with a thick apron of brush and gravel in alternate layers, to a distance of one hundred yards into the water from the foot of the slope.

On some parts of the coast of France, where it has been found necessary to protect it from encroachments of the sea, a cross section has been given to the dikes towards the sea, of the same form as the one which the shore naturally takes from the action of the waves. The dikes in other respects are constructed and faced after the manner which has been so long in practice in Holland.

**900. Groins.** Constructions, termed *groins*, are used whenever it becomes necessary to check the effect of the current along the shore, and cause deposits to be formed. These are artificial ridges which rise a few feet only above the surface of the beach, and are built out in a direction either perpendicular to that of the shore, or oblique to it. They are constructed either of clay, which is well rammed and protected on the surface by a facing of fascines or stones; or of layers of fascines; or of one or two rows of short piles driven in juxtaposition; or any other means that the locality may furnish may be resorted to; the object being to interpose an obstacle, which, breaking the force of the current, will occasion a deposit near it, and thus gradually cause the shore to gain upon the sea.

**901. Sea-walls.** When the sea encroaches upon the land, forming a steep bluff, the face of which is gradually worn away, a wall of masonry is the only means that will afford a permanent protection against this action of the waves. Walls made for this object are termed *sea-walls*. The face of a sea-wall should be constructed of the most durable stone in large blocks. The backing may be of rubble or of beton. The whole work should be laid with hydraulic mortar.



## APPENDIX.

**a. Classification of Strains.**—Any rod, or bar of homogeneous structure and uniform cross-sections, may be regarded as a prism, composed of an infinite number of fibres, each of which may, in turn, be considered as a right prism, having an infinitely small area for its base, and its edges parallel to those of the prism.

If a prism so composed be intersected by an infinite number of planes, each perpendicular to its edges, these planes will divide the fibres into infinitely small solids, each of which may be considered as the element of a fibre; and if these elementary solids, or fibres, be referred, in the usual manner, to three rectangular axes, two of which, as **X**, and **Y**, are contained in a plane perpendicular to the edges of the prism, and the third, **Z**, parallel to them, then the area of any elementary fibre will be expressed by  $dx dy$ , and its length by  $dz$ .

**b.** In considering the elementary fibres contained between any two of these consecutive planes, it will be readily seen that, although the relative positions of the planes may be varied in an infinity of ways, they admit of four simple relative movements, which, either singly or combined, will cover all the cases of change of form in the elementary fibres between them, arising from these changes of positions.

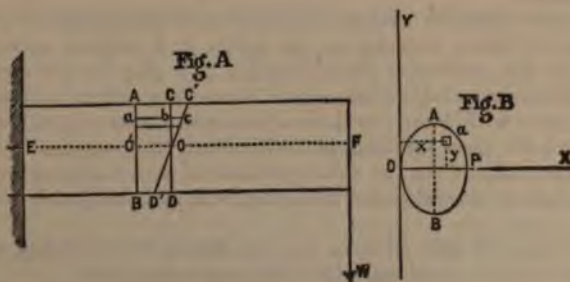

**c.** As an illustration of this, let (Fig. A) be the longitudinal, and (Fig. B) the cross-section of any such prism, and **AB**, and **CD**, be two of the consecutive planes in question.



1st. The plane,  $CD$ , may be moved parallel to  $AB$ , either from or towards it. In the former case, the elementary fibres between the planes will be lengthened, and in the latter shortened; and the strains to which they are subjected will arise from a force of extension in the first case, and one of compression in the second, acting parallel to the fibres.

2d. The plane,  $CD$ , may take the position,  $C'D'$ , by turning around some line,  $O$ , in it as an axis, in which case the elementary fibres on one side of this axis, in conforming to the new position of  $CD$ , will be deflected and lengthened, undergoing a strain of tension; whilst those on the opposite side will be deflected and shortened, undergoing a strain of compression; and those, as  $OO'$ , in the plane of the axis of the prism and of the axis  $O$  of rotation, will be simply deflected, without any change in their original length; the plane,  $CD$ , in its new position  $C'D'$ , continuing normal to all the elementary fibres in their new position of deflection.

3d. The plane,  $CD$ , (Fig. C) may receive a motion of translation in the direction  $CD$ , parallel to  $AB$ , in which any elementary fibre, as  $a$ , will take a new position, as  $a'$ , oblique to its original position.

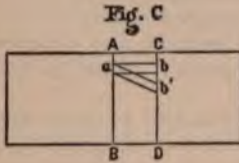

4th. Or the plane,  $CD$ , may receive a motion of rotation around some axis perpendicular to it, in which case, the base of any elementary fibre, as  $b$ , in the plane  $CD$  (Fig. B), will take a new position, describing a small arc in the plane,  $CD$

around the axis of rotation.

It will now be easily apprehended that any elementary fibre being subjected to two or more of these movements combined, the resulting strains brought upon it will arise from these simultaneous movements.

As these relative changes of position of the planes in question are due to forces exterior to the prism, and as their action is resisted by the molecular forces brought into play by the strains on the fibres, several problems arise, from this action and reaction which come within the province of rational mechanics, aided by experiment, for their solution, and which find their application in the resistances offered by the solid portions of structures to the forces to which they are subjected from the form and design of the structure.

The object of this *Note* is to give the mode of solving some of the more simple problems which fall under this head.

d. *Relation between the Elongation and the Force by which it is produced, in the case of a rod or bar of a given cross-section, the force acting in the direction of the axis of the bar.*

From experiments made upon homogeneous bars of small area of cross-section, and within the limits of elasticity of the material of

which the bar is composed, it has been shown that the elongation, from any force acting in the direction of the axis of the bar, is directly proportional to the length of the bar, and to the force itself, and inversely as the area of the cross-section.

Represent (Fig. D) by

$L$ , the original length of the bar.

$W$ , the force applied to lengthen it.

$l$ , the elongation due to  $W$ .

$A$ , the area of the cross-section.

$E$ , a constant to be determined by experiment.

Then, from the law expressed above, obtained from experiment, there obtains the relation

$$l = \frac{W L}{E A},$$

hence

$$W = E A \frac{l}{L}; \quad (A)$$

and

$$E = \frac{W}{\frac{A}{l} \frac{L}{L}} \quad (B)$$

Equation (A) gives the relation between the force and its corresponding elongation; and Eq. (B) shows that the ratio of the strain on the unit of area, expressed by  $\frac{W}{A}$ , and the elongation of the unit of length expressed by  $\frac{l}{L}$  is constant. The value of the constant depending on the nature of the material.

Making  $A = 1$  and  $\frac{l}{L} = 1$ , in Eq. (B), there obtains

$$E = W,$$

that is,  $E$  is the force which, applied to a bar, the cross-section of which is a superficial unit, would produce an elongation equal to the original length of the bar, supposing its elasticity perfect up to this limit. The quantity,  $E$ , thus defined is termed the *coefficient of elasticity*.

Equation (A) may be stated as the fundamental proposition in this subject upon which the solution of all the others depends.

*e. To find the relations between the Elongation and the Forces producing it, when the weight of the bar is taken into consideration.*



In Eq. (A), the only force acting is  $W$ , the weight of the bar itself being neglected. To determine the elongation, the latter being taken into account,

Represent (Fig. D) by

$L$ , the total original length of the bar ;

$A$ , the area of the cross-section ;

$x$ , the original length of any portion as  $A C$  ;

$dx$ , the length of an elementary portion of  $A C$  ;

$W$ , the force applied at the end  $B$  ;

$w$ , the weight of a unit of volume of the bar.

The volume of the portion  $B C$  will be expressed by  $(L - x) A$  ; and its weight by  $(L - x) A w$ .

The total force acting to elongate the portion  $A C$  will be expressed by

$$W + (L - x) A w.$$

The relations, therefore, between this force and the elongation produced by it on any elementary portion  $dx$ , will be obtained by substituting  $dx$  for  $L$ , and  $W + (L - x) A w$  for  $W$ , in Eq. A. Making these substitutions, and finding the corresponding elongation, there obtains

$$l = \frac{W + (L - x) A w}{E A} dx$$

The total length of  $dx$  after elongation will, therefore, be

$$dx + \frac{W + (L - x) A w}{E A} dx$$

Integrating this between the limits  $x = 0$  and  $x = L$ , there obtains

$$L + \frac{W L}{E A} + \frac{\frac{1}{2} w L^2 A}{E A},$$

for the total length of the bar after elongation.

f. It will be readily seen, from the preceding discussion, that the greatest strain on the bar will be at the top, and that it will arise from the force,  $W$ , and its own weight, or from  $W + L A w$ . The strains on the other sections varying with  $x$ , will, therefore, decrease as  $x$  increases. Consequently, the strain on each unit of area of the bar will be variable ; and, representing by  $x$  any variable length, as  $B C$ , estimated from  $B$  upwards, the force acting on the unit of area at any point to produce this strain will, from Eq. (A) be expressed by,

$$\frac{W + x A w}{A} = E \frac{\lambda}{x}; \text{ (C)}$$

in which  $\lambda$  is the elongation corresponding to  $x$ ; and in order that

the strain shall be the same on the unit of area of every section, and therefore equally strong at each section,  $\frac{\lambda}{s}$  must be constant.

g. To apply this, let the cross-section of the bar (Fig. E) at every point be a circle, and let the radius of any one of these circles be represented by  $r$ .

The area of the circle will be

$$\pi r^2,$$

and,  $dx$  being an elementary length of the bar, any elementary volume will be expressed by

$$\pi r^2 dx,$$

and the weight of this elementary volume by

$$\pi r^2 dx w.$$

For any volume of the bar of the length  $x$ , the expression for the weight will be

$$w \int \pi r^2 dx.$$

Substituting these values, in Eq. (C), for  $A$ , and

$x A w$ , and making  $\frac{\lambda}{x} = c$ , there obtains

$$\frac{W + w \int \pi r^2 dx}{\pi r^2} = E c; \quad (D)$$

to represent the strain on the unit of area on any cross-section.

Differentiating Eq. (D) there obtains,

$$w \pi r^2 dx = E c 2 \pi r dr,$$

hence

$$\frac{dr}{r} = \frac{w}{2 E c} dx,$$

which integrated gives

$$\log. r = \frac{w}{2 E c} x + C;$$

which shows that the line cut from the bar, by a section through the axis, is a logarithmic curve.

Making  $\pi r^2 = A$ , and  $E c = m$ , in Eq. (D), there obtains

$$W + w \int A dx = m A; \quad (E)$$

hence, by differentiation,

$$w A dx = m d A;$$

and

$$\frac{d A}{A} = \frac{w}{m} dx.$$

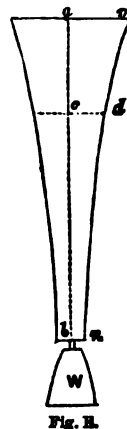

Fig. E.

Integrating this expression between the limits of  $x = 0$ , and  $x = L$ , and representing by  $A'$ , and  $A''$ , the corresponding values of  $A$ , and in which  $r$  will take the corresponding values  $r' = b n$ , and  $r'' = a m$ , there obtains

$$\log. \frac{A''}{A'} = \frac{w}{m} L;$$

hence, passing to the equivalent numbers,

$$A'' = A' e^{\frac{w}{m} L}; \quad (F)$$

But, from Eqs. (D) and (E), the quantity  $E \epsilon = m$ , is evidently the weight or force of tension, on the unit of area at any cross-section of the bar; so that, at the lowest point, where the strain arises from the force  $W$  alone, the total strain on  $A$  will be expressed by  $m A'$ ; hence

$$m A' = W, \text{ and } A' = \frac{W}{m}.$$

Substituting this value of  $A$ , in Eq. (F), there obtains

$$A'' = \frac{W}{m} e^{\frac{w}{m} L},$$

for the value of the area at the upper end.

*h. Relations between a force which produces simple deflection and the elongations and compressions of the fibres of a bar, the cross-section being uniform and symmetrical with respect to the plane in which the force acts.*

In the problem here proposed for solution, the circumstances are the same as those that usually obtain in all structures subjected to forces which act either obliquely or perpendicularly to the fibres of the material of which the parts are composed; as, for example, in the various kind of frames.

In all such cases, the cross-sections of the parts are either uniform, or else they vary by insensible degrees, by a law of continuity from one point to another; the figures of the cross-section, at any two points at finite distances apart, being similar, but regarded as the same between any two sections infinitely near each other.

It has been stated, in the illustration already given, that, in the case of simple deflection, the hypotheses generally adopted are: 1st, that the planes of cross-section, perpendicular to the fibres of any bar, taken at distances infinitely near each other, will remain normal to the fibres after deflection; 2d, that these planes will rotate around some line drawn across the figure of the cross-section;

3d, that the fibres lying on one side of this line will be extended, and those on the other compressed; 4th, that the elongation or compression of any fibre will be proportional to its distance from this line; and 5th, that all the fibres contained in a plane passed through this line and parallel to the axis of the bar, will not be changed in length by the deflection undergone. The central fibre in this plane is termed the *mean or neutral fibre*.

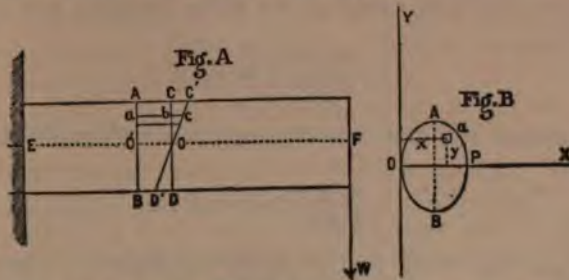

Let (Fig. A) be the longitudinal section, and (Fig. B) the figure of the uniform cross-section, taken at any point as  $AB$  (Fig. A), and which is symmetrical with the line  $AB$  (Fig. B) cut from the plane of cross-section by the plane passed through the axis of the bar, and in which a force,  $W$ , acts at the point  $F$ , to cause deflection in the bar, which may be supposed to be fixed in any manner at the point  $E$ . Let  $EF$  be the mean fibre cut out by the plane of longitudinal section, and  $OP$  the line of the fibres, cut by the plane of cross-section, which are not changed in length by the deflection; and which may be termed the *neutral axis* of the cross-section. Let  $OX$  and  $OY$  be two rectangular co-ordinate axes to which all points of the cross-section are referred.

Represent by

$L$ , the original length of an elementary fibre as  $DB$ ,  $a$ ,  $b$ , (Fig. A)

$a = dx dy$  the area of its cross-section;

$x$  and  $y$ , the co-ordinates of  $a$ ;

$\alpha$ , the infinitely small angle which the plane  $C'D'$  makes with its original position  $CD$  after deflection.

Now, from the hypothesis adopted, any fibre, as  $ab$  (Fig. A), contained between two consecutive planes, will, after deflection, be lengthened by an amount equal to  $b'c'$  in the relative change of position of the plane  $CD$ ; and as the distance of this fibre from the neutral axis is  $y$ , this increase of length will be expressed by,

$$y \alpha;$$

in like manner, the decrease in length of any fibre at the same distance from the neutral axis, on the other side of it, will also be expressed by  $y \alpha$ .

Resuming now Eq. (A), and substituting in its second member  $dx dy = a$  for  $\Delta$ , and  $y a$  for  $l$ , there obtains

$$E dx dy \frac{y a}{L},$$

which expresses the relation between the strain, and the corresponding elongation for any elementary fibre.

Therefore the total strain on the fibres elongated will be expressed by

$$\frac{a}{L} \iint E dx dy y.$$

In like manner the strains on the compressed fibres will be expressed by

$$-\frac{a}{L} \iint E dx dy y;$$

the negative sign being used to denote the contrary direction of the elastic resistance of the compressed fibres.

As these strains are caused by the force  $W$  acting to deflect the bar, and therefore to produce rotation about any neutral axis, as  $OP$ , with an arm of lever  $OF = z$ , there will obtain, to express the conditions of equilibrium of the system of forces,

$$\frac{a}{L} \iint E dx dy y - \frac{a}{L} \iint E dx dy y = 0; \text{ (G)}$$

and

$$\frac{a}{L} \iint E dx dy y^2 + \frac{a}{L} \iint E dx dy y^2 - Wz = 0; \text{ (H)}$$

Eq. (G), which expresses the condition that the algebraic sum of the strains on all the fibres, parallel to the mean fibre  $EF$ , and perpendicular to the plane  $C'D'$ , is equal to zero, shows that the neutral axis,  $OP$ , passes through the centre of gravity of the figure of the cross-section; and Eq. (H) that the sum of the moments of the strains and of the force  $W$  is also equal to zero.

When the centre of gravity coincides with the centre of figure, or the neutral axis divides the cross-section symmetrically, Eq. (H) becomes,

$$2 \frac{a}{L} \iint E dx dy y^2 - Wz = 0. \text{ (I)}$$

1. The expression

$$\iint E dx dy y^2$$

it will be seen is analogous to the general expression for the moment of inertia of a volume of uniform density, in which  $E$  is con

stant and depends only on the physical properties of the material, and  $\iint dx dy y^2$  depends entirely for its value on the figure of the cross-section. To apply this to any particular figure, the integral must be taken between  $x = 0$ , and  $x = b$ , in which  $b$  is the breadth of the figure estimated along the neutral axis; and between  $y = 0$ , and  $y = \frac{1}{2} d$ , in which  $d$  is the length of the figure, estimated along the line drawn through its centre, and perpendicular to the neutral axis.

The expression  $2 \iint E dx dy y^2$  is called the *moment of flexibility*; and  $Wz$  that of the *bending moment*.

k. *Particular moments of flexibility.*—The value of the moment of flexibility, which is a mere problem of calculus, is easily found, for any geometrical figure from the double integral  $\iint dx dy y^2$ .

For examples, when the cross-section of the figure is a rectangle (Fig. F), in which  $b$  is the breadth, and  $d$  the depth, the integral, taken within the limits  $x = 0$ , and  $x = b$ ;  $y = 0$ , and  $y = \frac{1}{2} d$ , becomes

$$2 \iint dx dy y^2 = \frac{1}{12} b d^3.$$

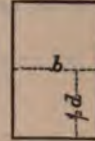

Fig. F.

2. For a cross-section (Fig G), like that of a hollow girder, in which  $b$  is the entire breadth,  $d$  the total depth,  $b'$  the breadth of the hollow interior,  $d'$  its depth, the limits become,  $x = b - b'$ ; and  $y = \frac{1}{2} d - \frac{1}{2} d'$ ; and the moment of flexibility,

$$2 \iint dx dy y^2 = \frac{1}{12} (b d^3 - b' d'^3).$$

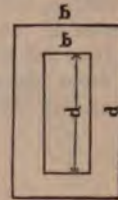

Fig. G.

The expression will be of the same form in the case of the cross-section of the I girder (Fig. H) in which  $b$  is the breadth of the flanges;  $b'$  the sum of breadths of the two shoulders;  $d$  the depth of the girder, and  $d'$  the depth between the flanges.

3. When the cross-section is a circle, and the axes of co-ordinates are taken through the centre, the limits of  $x$  will be  $+ r$  and  $- r$ ; and those of  $y = \sqrt{r^2 - x^2}$  will be the same; and

$$2 \iint dx dy y^2 = \frac{1}{4} \pi r^4*$$

4. For a hollow cylinder, in which  $r$  is the exterior and  $r'$  the interior radius, the integral is  $\frac{1}{4} \pi (r^4 - r'^4)$ .

5. When the cross-section is an ellipse, and the neutral axis coincides with the conjugate axis, if the transverse axis be represented by  $d$ , and the conjugate by  $b$ , and the limits of  $x$  and  $y$  be taken as in the circle, then,

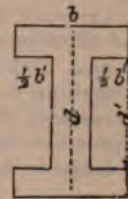

Fig. H.

\* For the integral  $\iint_{-r}^r dx dy y^2$ , see *Church's Calculus*, art. 195, p. 271; and art. 252, p. 341



$$2 \iint dx dy y^2 = \frac{1}{64} \pi b d^3.$$

l. *Strain on the unit of area.*—Returning to the general expression Eq. (I), by representing  $2 \iint dx dy y^2$  by I, it becomes

$$\frac{\alpha}{L} = \frac{Wz}{EI}; \quad (I')$$

multiplying each member of this equation by  $y$ , there obtains,

$$\frac{y\alpha}{L} = \frac{Wz}{EI} y, \text{ or } E \frac{y\alpha}{L} = \frac{Wz}{I} y. \quad (K)$$

But  $y\alpha$  is the elongation of the elementary fibre L at the distance  $y$  from the neutral axis, therefore, Eq. (A), as

$$\frac{W}{A} = E \frac{l}{L},$$

is the strain on the unit of area, so  $E \frac{y\alpha}{L} = \frac{Wz}{I} y$  is the strain referred to the unit of area caused by the deflection on the elementary fibre at the distance  $y$  from the neutral axis.

Taking, for example, a bar having a uniform rectangular cross-section of the depth  $d$  and breadth  $b$ ; and representing by R the limit of the strain on the unit of area of the fibres at the distance  $\frac{1}{2}d$  from the neutral axis, and for  $y$ , substituting  $\frac{1}{2}d$ , and for I its value  $\frac{1}{12}b d^3$ ; there obtains, from Eq. (K),

$$R = \frac{Wz}{\frac{1}{12}b d^3}; \quad (L)$$

which expresses the relations that must exist between  $b$ ,  $d$ ,  $W$  and  $z$  to satisfy this condition.

m. The quantity  $\frac{1}{12} R b d^3$  receives the name of the *moment of rupture*, when R is the strain on the unit of surface at the instant that rupture takes place; and its value has been determined by direct experiment as stated in the subject of the Resistance of Materials. But it is to be noted that as the proportionality of the elongations or compressions of the fibres to the forces causing them is true only within certain limits, and that it fails when the strain approaches that of rupture, the results obtained from Eq. (L) will be found to accord with experiment only within these limits.

n. The equation  $R = \frac{Wz}{I} y$  is used for determining the strength and proportions of prismatic beams. If the beam is prismatic it is evi

dent that the greatest strain will be where the moment of external forces is greatest, and the transverse section at this point is called the *dangerous section*; and generally it is the section most liable to break in any beam.

*Case 1st.* If the beam is fixed at one end and loaded at the free end (Fig. a) we have for the dangerous section

$$R = \frac{Wl}{I} y$$

in which  $l$  is the length of the beam.

If the beam is rectangular this becomes

$$R = 6 \frac{Wl}{b d^2}$$

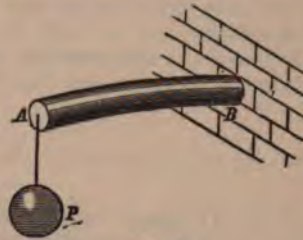

Fig. a.

If it is required to find the depth, we assume a safe value for  $R$ , and have

$$d = \sqrt{\frac{Wl}{6 R b}}$$

In a similar way we may find any one of the quantities when all but one are known.

*Case 2d.* If the beam is uniformly loaded (Fig. b) we have for the dangerous section

$$\frac{1}{2} Wl = \frac{1}{4} R b d^2$$

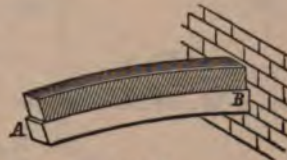

Fig. b.

*Case 3d.* If the beam is supported at its ends and loaded by a weight,  $P$ , placed at the middle (Fig. c), the dangerous section will be at the middle, and we shall have for rectangular beams,

$$\frac{1}{4} P l = \frac{1}{8} R b d^2,$$

in which  $l$  is the length  $AB$  between the supports.

*Case 4th.* If the beam is uniformly loaded and the other conditions the same as in the preceding case, we have

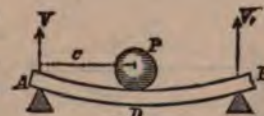

Fig. c.

$$\frac{1}{8} Wl = \frac{1}{8} R b d^2$$

(For other cases, see *Wood's Resistance of Materials*.)

n. *Solids of Equal Resistance.*—A like problem presents itself

in strains caused by deflection, to the ones in which the strains are caused by a force acting in the direction of the fibres; in which, the cross-sections, varying from point to point, but being similar figures, it is proposed so to determine the longitudinal section, that the greatest strain on the unit of area for each cross-section shall be constant.

Representing this constant strain by  $R'$ , and supposing the cross-sections to be rectangles, Eq. (L) becomes

$$R' = \frac{Wz}{\frac{1}{b} d^2} \quad (L')$$

Now Eq. (L') may be satisfied in various ways; by making  $W$  either constant, or variable with  $z$ ; by making either  $b$  or  $d$  constant, or variable; or by making any one of these quantities to vary with the other.

The following cases may be taken as examples of the applications of Eq. (L'):—

*Case 1st.* Suppose a bar (Fig. I), the cross-section of which at every point is a rectangle, with a constant breadth, but variable depth, to be fixed at one end in any manner, and strained by a constant force  $W$ , acting, at the other, in the plane containing the mean fibre, and perpendicular to this fibre. For any cross-section at the distance  $z$  from the point of applica-



Fig. I.

tion of  $W$ , representing the variable depth by  $y$ , Eq. (L') becomes,

$$R' = \frac{Wz}{\frac{1}{b} b y^2} \therefore y^2 = \frac{6 W}{b R'} z;$$

which is the equation of a parabola, the vertex of which is at the point B. Assuming the line  $AB$  of the longitudinal section to be a straight line, the line  $BD$  which bounds the figure on the opposite side will be the parabola given by the equation.

*Case 2d.* If the strain arises from a weight uniformly distributed along the line  $AB$  (Fig. K), and that for a unit of length of the line, the corresponding weight is represented by  $w$ ; then, for any distance  $z$  from  $B$ , the weight will be  $wz$ , and its lever arm, for the cross-section at the distance  $z$  from  $B$ , will be  $\frac{1}{2} z$ . If then the breadth remains constant and

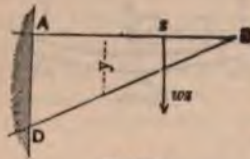

Fig. K.

depth variable, Eq. (L') will take the form,

$$R' = \frac{w z \cdot \frac{1}{2} z}{\frac{1}{2} b y^2}, \therefore y^2 = \frac{3 w}{R b} z^2, \text{ and } y = \sqrt{\frac{3 w}{R b}} z;$$

which is the equation of a right line **BD** of which **B** is the origin of co-ordinates.

*Case 3d.* Taking **W** as in the first case, let the ratio of *b* to *a* be constant, or  $b = dm$ , then Eq. (L') will become

$$R' = \frac{Wz}{\frac{1}{2} m y^2}, \therefore y^2 = \frac{6 W}{R' m} z.$$

which is the equation of a cubical parabola for the curve (Fig. K)

*Case 4th.* Taking **W** as in the first case, let the depth *d* (Fig. L), be constant, and the breadth variable. Representing this variable breadth by *x*, Eq. (L') becomes

$$R' = \frac{Wz}{\frac{1}{2} x d^2}, \therefore x = \frac{6 W}{R' d^2} z;$$

which is the equation of a right line having the origin of co-ordinates at **B**. The figure of the longitudinal section perpendicular to the line of action of **W** will be an isosceles triangle, **CBD**.

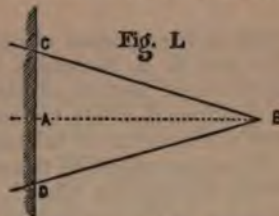

*Case 5th.* Supposing, as in the second case, an equal weight *w* on each unit of length to be distributed along the centre line **AB** (Fig. M), and the depth to be constant and breadth variable. Then for any cross-section at the distance *z* from **B**, Eq. (L') becomes,

$$R' = \frac{\frac{1}{2} w z^2}{\frac{1}{2} x d^2}, \therefore x = \frac{3 W}{R' d^2} z^2;$$

which is the equation of a parabola having its vertex at **B**, at which point **AB** is tangent. The figure of the longitudinal section will therefore be bounded by the two equal and symmetrical parabolic arcs **BC** and **BD**.

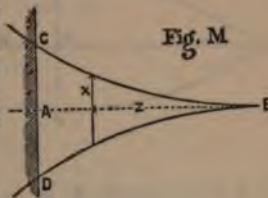

*Case 6th.* Supposing a bar to rest horizontally on two supports, **A, B** (Fig. N), at its two extremities, and to be strained by a weight **W** acting at any point **D**, and that its depth is variable and breadth constant. Represent the length **AB** by  $2l$ , and the distance **CD** between the middle point of **AB** and the cross-section where **W** acts by *z*.

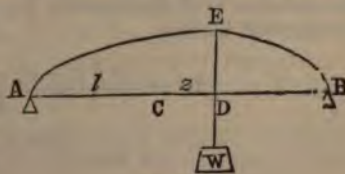

From the theorem of parallel forces, the pressures on the points **A** and **B**, and consequently their reaction, are the parallel components of **W** acting at these points, and are expressed for the point **A**, by  $\frac{l-z}{2l} W$ , and for **B** by  $\frac{l+z}{2l} W$ ; and their respective moments, with regard to the neutral axis in the cross-section at **D**, by  $\frac{(l-z)(l+z)}{2l} W$ . Eq. (L'), therefore for any cross-section, becomes

$$R' = \frac{W(l^2 - z^2)}{2l} \cdot \frac{1}{\frac{1}{2} b y^2} \therefore y^2 = \frac{3W}{R' b l} (l^2 - z^2);$$

which is the equation of an ellipse referred to its centre and axis. The line **AB**, therefore, being a right line, the outline of the longitudinal section of the bar on the opposite side will be the semi-ellipse **AED**; the semi-conjugate axis of which can be found from the equation of the curve by making  $z = 0$ .

Were the weight **W** to act at the point **D** alone, then the problem would fall into the *Case 1*, and the longitudinal section would be bounded by the two parabolic arcs **AE** and **BE**.

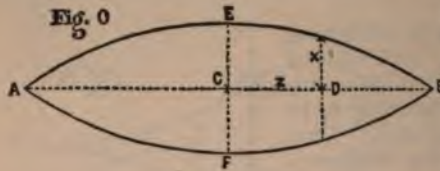

*Case 7th.* Supposing a bar to rest, as in the preceding case, on two supports, **A, B** (Fig. 0), and a weight  $w$  to be distributed over each unit of length of the centre line **AB**; the depth of the bar  $d$  to be constant, and the breadth variable. Representing

by  $2l$  the length **AB**, and by  $z$ , the distance **CD** of any cross-section from the centre **C**, then, from the theorem of parallel forces, as  $2wl$  is the total weight distributed over **AB**, the pressure on each support and consequent reaction will be  $wl$ . But the weight distributed over the portion **DB** is expressed by  $w(l-z)$ . The cross-section at **D** will therefore be strained by the two forces  $wl$  acting at **B** upwards; and  $w(l-z)$  acting through the middle of the distance **DB** downwards, Eq. (L') to conform to these circumstances will become

$$R' = \frac{wl(l-z) - \frac{1}{2}w(l-z)(l-z)}{\frac{1}{2}x a^2},$$

$$\therefore x = \frac{\frac{1}{2}w l^2 + \frac{1}{2}w z^2}{\frac{1}{2}R' a^2},$$

which is the equation of a parabola referred to the co-ordinate axes

**C B, C E.** The longitudinal section perpendicular to the line of action of the force  $2 w l$  will be bounded by two parabolic arcs **A E B**, and **A F B**, the vertices of which will be on the line **E F** bisecting **A B**.

*Case 8th.* If, instead of a weight uniformly distributed along the centre line, a weight **W** were placed at a point **D** (Fig. P) of this line, then the moment of either component of **W** at **A**, or **B**, with respect to the transverse section at **D** will be equal to the moment of flexibility at this section. This case therefore is the same as in *Case 4*, and the outline of the longitudinal section will be two isosceles triangles, having a common base **E F**, and their vertices at **A** and **B**.

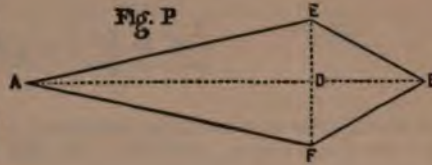

If, as in *Case 6th*, the weight may act at any point, then the outline will be two parabolic arcs, having their vertices on the perpendicular to and bisecting **A B** as in *Case 7th*.

**O.** *Effect of the figure of the cross-section on the resistance to strains caused by deflection.*

From Eq. (K) which gives the strain on the unit of area for any fibre at the distance  $y$  from the neutral axis, or

$$R = \frac{Wz}{I} y,$$

there obtains

$$\frac{Wz}{\frac{I}{y}} = R.$$

From this it is seen, that, for any constant value of the bending moment  $Wz$ , the strain  $R$  on the unit of area for any fibre, at the distance  $y$  from the neutral axis, will be the smaller as  $\frac{I}{y}$  is the greater. But for any two cross-sections, having the same area  $A$ , in which  $y = \frac{1}{2} d$  is the distance of the extreme fibre from the neutral axis  $I$  will be the greater as  $\frac{1}{2} d$  is the greater. These considerations therefore give a very simple means of comparing the relative resistance offered to deflection by cross-sections of equivalent areas, but of different figures.

Taking, for examples, the equivalent cross-sections in the rectangle (Fig. F), the ellipse, and the  $\perp$  girder (Fig. H), the respective values of  $\frac{I}{\frac{1}{2}d}$  are, for the rectangle,

$$\frac{I}{\frac{1}{2}d} = \frac{1}{2} b d^2 = \frac{1}{2} b d \cdot d = \frac{1}{2} A d;$$

for the ellipse, the area of which is  $\frac{1}{2} \pi b d$ , there obtains,

$$\frac{I}{\frac{1}{2}d} = \frac{\frac{1}{4} \pi b d^2}{\frac{1}{2}d} = \frac{1}{2} A d;$$

for the  $\perp$  cross-section, if the breadth  $b - b'$  of the web connecting the two flanges be so small that its area may be neglected in estimating the quantity  $I$ , and in like manner the thickness  $d - d'$  of the flanges be also so small, as compared with  $d$ , that it may also be neglected in the same way, then the value of  $I$  will nearly approach to the quantity  $\frac{1}{2} A d^2$ , in which  $A$  is the area of the flanges, therefore

$$\frac{I}{\frac{1}{2}d} = \frac{\frac{1}{2} A d^2}{\frac{1}{2} d} = \frac{1}{2} A d.$$

Comparing the three values above of  $\frac{I}{\frac{1}{2}d}$ , it is apparent, that,  $A$  being the same in each, the cross-section of greatest resistance is that of the  $\perp$  form; and that of the rectangle is greater than in the ellipse. And that in each,  $A$  remaining the same, but  $b$  varying inversely as  $d$ ,  $\frac{I}{\frac{1}{2}d}$  will increase with  $d$ . This shows that the mass of the fibres should be thrown as far from the neutral axis, which in each of these cases is taken to bisect the distance  $d$ , as the limits of practice will allow. Hence is seen the advantage presented in the cross-sections of Figs. G and H.

p. *Shearing Strain*.—This term is applied to the resistance offered by the fibres to a force acting in a plane perpendicular to them, as illustrated by Fig. C; and the force producing the strain is termed a *shearing force*.

The result of the action of such a force would be such, for example, as would be seen in the distortion that would take place in a very short bar of great relative stiffness, like a nail or peg, which, firmly fixed at one end, should be strained by a force acting on the projecting part perpendicular to its axis.

Comparatively few experiments have been made to determine the amount of resistance offered to this kind of strain. But from the evident analogy of the phenomena in this case to those in the case of the direct elongation of the fibres, writers on the subject have proposed to express the relations between the distortions of the fibres and the forces producing them by formulas analogous to those for the forces and resistances in the cases of direct elongations.

Represent (Fig. C) by

$L$ , the original length of any fibre  $a b$  between the two consecutive planes  $A B$  and  $C D$ .

$\gamma$ , the distance  $b b'$  which every point of the plane  $C D$  has moved in the direction of  $C D$ , relatively to the plane  $A B$ , owing to the force causing this displacement.

$t$ , the strain on any fibre.

$\alpha$ , the area of the cross-section of any fibre.

$G$ , a constant.

Now, in the displacement of  $a b$  from the position  $a b$  to  $a b'$ , it may be assumed from analogy, that the resistance to this displacement is, on the one hand, proportional to  $\alpha$ ; and on the other, to

$\frac{\gamma}{L}$ , which is the measure of this displacement referred to the unit of length. To express the hypothesis there obtains

$$t = G \alpha \frac{\gamma}{L}; \text{ (M)}$$

in which  $G$  may be considered either as constant for any elementary fibre, or as variable from one fibre to another. In either case there obtains

$$\frac{\frac{t}{\alpha}}{\frac{\gamma}{L}} = G; \text{ (N)}$$

which expresses the ratio between the strain on the unit of area of any fibre and the displacement of this area corresponding to a unit of length.

Representing by  $T$  the entire resistance to this displacement of  $C D$ ; by  $A$  its area; and assuming  $G$  as constant throughout its area, there obtains from Eq. (M)

$$T = G A \frac{\gamma}{L}; \text{ (O)}$$

It has been proposed to call the quantity  $E$ , in the preceding analogous expression, *modulus of longitudinal elasticity*, and the quantity  $G$  in this *modulus of lateral elasticity*.

So far as determined by experiment, the ratio of the two quantities, or  $\frac{E}{G}$ , differs but little from 3, for amorphous bodies, but in fibrous bodies there is no definite ratio.

From the preceding discussions it will be seen, from the hypothe

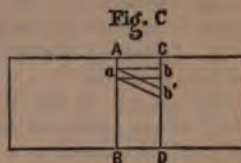



sis adopted, that the resultant of the resistances offered by the longitudinal and lateral elasticities of any material to a strain, caused by any force which calls into action these two resistances, passes through the centre of gravity of the resisting section, this point is termed the *centre of elasticity*.

q. *Limits of the resistance on the unit of area to a longitudinal, or lateral strain.*

By means of the fundamental formulas (A), (L), and (O) the limit of the strain on the unit of area, at the fibre where the strain is greatest, caused by a force acting in the plane of symmetry of the cross-section, whether perpendicular or oblique to the direction of the mean fibre, can be readily determined.

Supposing the force to be oblique to the mean fibre, it can be resolved into two components, one P perpendicular to the direction of the fibre, the other Q parallel to it. The component P will produce a deflection, which will give rise to a certain amount of compression, or extension in the extreme fibre, the value of which, for the unit of area, can be found from formula (L). In like manner the component Q will cause a certain amount of compression, or extension, the value of which, for the unit of area, can be found from the formula (A). Now these strains being in the direction of the fibres, their amount on the unit of area for the extreme fibre, will be equal to the sum of the two calculated from formulas (A) and (L); and should not be greater than the resistance R that can be offered with safety to the unit of area in question; or

$$\frac{P \times d}{I} \cdot \frac{d}{2} + \frac{Q}{A} = R;$$

in which  $\frac{d}{2}$  is the distance of the extreme fibre from the neutral axis; and A is the area of the cross-section.

The component P is also the amount of the shearing force on any cross-section; and the resistance to it on the unit of area can be found from formula (O), denoting by R' its limit there obtains

$$\frac{P}{A} = G \frac{\gamma}{L} = R'.$$

for this limit.

If the strain, therefore, on the unit of area is in the one case less than R, and in the other less than R', the change which the fibres will undergo under the action of the force will be within the limits of safety.

It is important to remark, that the values of R and R', when the sign of equality is used in the two preceding expressions, cannot always be satisfied in practice for any assumed area of cross-section, although for economy of material it is desirable they should be. Taking, for example, a beam of a rectangular cross-section, the area

of which is expressed by  $b d$ , which is deflected by a pressure  $W$  acting with the arm of lever  $l$ , the two preceding expressions, in this case, taken as equalities, become

$$R = \frac{6 W l}{b d^3}, \text{ and } R' = \frac{W}{b d}.$$

As  $W$ ,  $l$ ,  $R$  and  $R'$  are given, the values of  $b d^3$  and  $b d$ , as determined from them can be represented by the equalities

$$b d^3 = m, \text{ and } b d = n;$$

hence, dividing the one by the other, there obtains  $d = \frac{m}{n}$ , and  $b = \frac{n^2}{m}$ . Now these values may be such as to make  $d$  so much greater than  $b$  as to be beyond the limits of practice; in which case a value should be given to  $d$ , such that the value of  $b$ , determined from the equality  $b d^3 = m$ , shall be within the rules of practice, as the strain from deflection is more to be guarded against than that from the shearing force. Whilst the limit from deflection should not be exceeded, neither should that from shearing be dangerously so.

r. *Relations between the strains and the forces producing them in the case of straight beams, or girders of uniform cross-section, resting on two points of support, in which the forces act transversely to the mean fibre.*

The case here given finds a number of applications in the combinations of straight beams of timber or iron in framing; in which it may be necessary to find the reactions of the points of support from the forces acting on the beam, the changes caused by the strains on the fibres, the amounts of the bending moment and the shearing force, with the view of so proportioning the figure and area of the cross-section as to resist the greatest strain to which the unit of area can be subjected at any point.

The strains on a beam, under the circumstances above, may arise either from a weight or pressure acting at one point between the supports; or from weights, or pressures of equal intensity uniformly distributed along the entire length of the beam; or from both of these combined. In either case the weights or pressures must be applied perpendicularly to the mean fibre of the beam, and the reaction of the supports taken vertical.

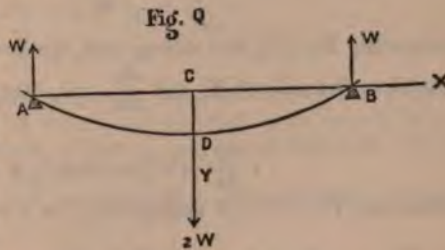

Case 1. (Fig. Q) *Beam resting horizontally on supports at each end, and strained by a force acting perpendicular to the mean fibre at its middle point.*

Represent by

$2l$ , the distance **AB** between the points of support.

$2W$ , the force applied at **C** the middle point.

$x$  and  $y$ , the co-ordinates of any point of the curve **ADB**, assumed by the mean fibre under the action of  $2W$ , referred to the axis **X** and **Y**, through **C**.

$\varepsilon = EI$ , the moment of flexibility, Eq. (I').

$\zeta$ , the radius of curvature at any point.

From the theorem of parallel forces, each point of support will furnish a reaction, expressed by  $-W$ , equal and contrary to the components  $W$  of  $2W$ . Then, from Eq. (I'), there obtains, to express the relations between the bending moment and the moment of flexibility, by substituting  $W(l-x)$  for  $Wz$ , and for  $L$ ,  $dx = \zeta \alpha$

$$\frac{\alpha}{\zeta \alpha} = -\frac{W(l-x)}{\varepsilon}, \text{ or } \frac{1}{\zeta} = -\frac{W(l-x)}{\varepsilon}; \quad (1)$$

and substituting for the radius of curvature  $\zeta$ , the value  $\frac{(dx^2 + dy^2)^{\frac{3}{2}}}{dx \, d^2y}$ ; there obtains,

$$\varepsilon \frac{\frac{d^2y}{dx^2}}{\left(1 + \frac{dy^2}{dx^2}\right)^{\frac{3}{2}}} = -W(l-x). \quad (2)$$

Regarding the deflection as very small,  $\frac{dy^2}{dx^2}$ , which is the square of the tangent to curve at the point  $x, y$ , may be omitted, and Eq. (2) becomes

$$\varepsilon \frac{d^2y}{dx^2} = -W(l-x). \quad (3)$$

Integrating Eq. (3), and noting that, for  $x=0$ , the tangent becomes parallel to the axis of **X**, and  $\frac{dy}{dx} = 0$ , there obtains

$$\varepsilon \frac{dy}{dx} = W(-lx + \frac{x^2}{2}). \quad (4)$$

Integrating Eq. (4), and noting that, for  $x=l, y=0$ , there obtains

$$y = \frac{W}{\varepsilon} \left(-\frac{lx^2}{2} + \frac{x^3}{6}\right) + \frac{W}{\varepsilon} \frac{l^3}{3} = \frac{W}{6\varepsilon} (l-x)(2l^2 + 2lx - x^2); \quad (5)$$

which is the equation of the curve **DB** of the mean fibre. The

greatest ordinate of the curve  $OD$ , represented by  $f$ , is obtained by making  $x = 0$ , Eq. (5); hence

$$f = \frac{1}{8} \frac{W}{s} l^2$$

*Case 2. (Fig. Q) Strain arising from a weight or pressure  $w$ , uniformly distributed over each unit of length of  $2l$ .*

In this case the reaction at each support will be  $-wl$ , and is equal and contrary to either of the two parallel components of  $2wl$ , the total weight.

For any distance  $l-x$  from  $B$ , the weight will be  $w(l-x)$  acting downward; the fibres therefore at the cross-section at the point,  $x, y$ , will have a strain caused by  $-wl$  acting upwards, and  $w(l-x)$  acting downwards. The moment of the force of reaction will be  $-wl(l-x)$ ; and that of  $w(l-x)$  will be  $w(l-x) \frac{1}{2}(l-x) = \frac{1}{2}w(l-x)^2$ . The bending moment therefore will be the algebraic sum of these two. Eq. (3) then becomes

$$s \frac{d^2y}{dx^2} = \frac{1}{2}w(l-x)^2 - wl(l-x) = -\frac{1}{2}w(l^2 - x^2). \quad (6)$$

Hence, by the same processes of integration as in Case 1,

$$s \frac{dy}{dx} = \frac{1}{2}w \left( \frac{x^3}{3} - l^2x \right); \quad (7)$$

$$y = \frac{1}{2} \frac{w}{s} \left( \frac{x^4}{12} - \frac{l^2x^2}{2} \right) + \frac{5}{24} \frac{w}{s} l^2. \quad (8)$$

$$= \frac{1}{24} \frac{w}{s} (l^2 - x^2) (5l^2 - x^2). \quad (9)$$

A comparison of the value obtained for  $f$ , the greatest ordinate, from Eq. (9), and for  $f$ , obtained from the following equation,

$$y^1 = \frac{5}{42} \frac{w}{s} l^2 (l^2 - x^2),$$

which is the equation of a parabola, obtained by omitting  $x^4$  in Eq. (9), the greatest value of which is  $l^2$ , as small with respect to  $5l^2$ , will show that the latter equation may be substituted for the former, as that of the curve  $ADB$ .

From either of the two preceding Eqs. there obtains, for  $f$  corresponding to  $x = 0$ ,

$$f = \frac{5}{24} \frac{w}{s} l^2.$$

To ascertain the position of the cross-section where the greatest

amount of this strain on the unit of area obtains, it will be necessary to examine the values of the bending moments

$$- W(l - x), \text{ and } - \frac{1}{2} w (l^2 - x^2),$$

in the two preceding cases. Each of these will be greatest for  $x = 0$ . Having this greatest value, its relation to the limit  $R$  can be found by the process already given.

The shearing force, which is  $W$  in the one case, and  $w x$  in the other, for any cross-section at the distance  $x$  from  $B$ , it is seen will be constant throughout in *Case 1*, but variable in *Case 2*. Having its greatest value for  $x = l$ , in the latter.

Taking the value of  $f$ , or the greatest amount of deflection in the two cases, it will be seen that, supposing  $f$  the same in both,  $W = \frac{2}{3} w l$ , or that the value of  $f$  obtained from the force  $2 w l$ , uniformly distributed, would be obtained by  $\frac{2}{3} w$  acting at the middle point  $G$ .

If it were desired that the greatest longitudinal tension on the unit of area should in each case be the same, then the greatest values of the two bending moments  $W(l - x)$ , and  $\frac{1}{2} w (l^2 - x^2)$ , must be equal, or,

$$W l = \frac{1}{2} w l^2, \text{ hence } W = \frac{1}{2} w l;$$

which shows that the greatest longitudinal tension on the unit of area when the weight is uniformly distributed is the same as what would arise from half this weight acting at the middle point  $C$ .

It is easy to apply the Eqs. in the preceding cases to the one in which there is weight  $2 W$  acting at the middle point, and one  $2 w l$  uniformly distributed, by remembering that the forces of reaction at  $A$  and  $B$  will be represented in this case by  $W$  and  $w l$ ; and that the bending moment for any cross-section will be the algebraic sum of the bending moments given in the two preceding cases.

*Case 3.* (Fig. R) *Beam having its two ends firmly held down on its supports; as, for example, a beam having its ends embedded in any manner in two parallel walls.*

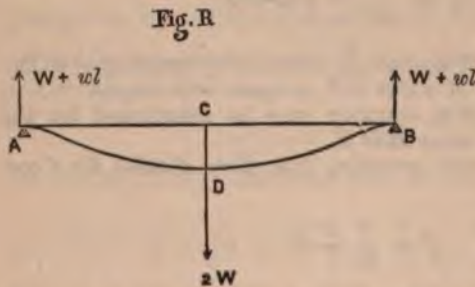

In this case, the strains are produced by a force  $2 W$  acting, as in *Case 1*, at the middle point, and one  $2 w l$  uniformly distributed as in *Case 2*. The circumstances differing from the other two, in that the ends of the beams are supposed to be held in a horizontal position by being firmly embedded. This condition may be sup-

posed to arise from forces acting vertically upon the embedded ends beyond the points of support **A B**.

With respect to either of these forces as the one at the end towards **B**, which may be represented by  $Y$ , it can be transferred to the point **B** by substituting a couple, in the usual manner, the moment of which being unknown may be represented by  $\mu$ . With respect to  $Y$ , it will be determined by the consideration that the reaction at each support will be  $W + w l$ .

Adopting the same notation as in *Cases 1 and 2*, the relation between the moment of flexibility, for any cross-section at the distance  $x$  from **B**, the bending moments, and the moment of the couple  $\mu$ , will be expressed by,

$$\begin{aligned} \varepsilon \frac{d^2 y}{dx^2} &= -W(l-x) - wl(l-x) + \frac{1}{2} w(l-x)^2 + \mu \\ &= -W(l-x) - \frac{1}{2} w(l^2 - x^2) + \mu, \quad (10) \end{aligned}$$

Integrating between the limits of  $x$ , and  $x = 0$ , there obtains,

$$\varepsilon \frac{dy}{dx} = -W\left(lx - \frac{x^2}{2}\right) - \frac{1}{2} w\left(l^2 x - \frac{x^3}{3}\right) + \mu x, \quad (11)$$

But as the tangents to the curve, both at **B** and **C**, are horizontal,  $\frac{dy}{dx} = 0$ , for the values,  $x = 0$  and  $x = l$ . From this last limit therefore, there obtains, from Eq. (11),

$$0 = -\frac{1}{2} W l^2 - \frac{1}{6} w l^3 + \mu l,$$

hence

$$\mu = \frac{1}{2} W l + \frac{1}{6} w l^2.$$

Substituting this value of  $\mu$  in Eq. (11) and reducing, there obtains

$$\begin{aligned} \varepsilon \frac{dy}{dx} &= -W\left(lx - \frac{x^2}{2} - \frac{lx}{2}\right) - \frac{1}{2} w\left(l^2 x - \frac{x^3}{3} - \frac{2}{3} l^2 x\right), \\ &= -\frac{1}{2} W(lx - x^2) - \frac{1}{6} w(l^2 x - x^3); \quad (12) \end{aligned}$$

Integrating Eq. (12), and noting that for  $x = l$ ,  $y = 0$ , there obtains,

$$\varepsilon y = \frac{1}{2} W\left(-\frac{lx^2}{2} + \frac{x^3}{3} + \frac{l^2 x}{6}\right) + \frac{1}{6} w\left(-\frac{l^2 x^3}{2} + \frac{x^4}{4} + \frac{l^3 x}{4}\right). \quad (13)$$

for the equation of the curve **A D B**.

Substituting  $x = 0$ , in Eq. (13), the corresponding value for  $y = f$  becomes

$$f = \frac{1}{12} \frac{l^3}{\varepsilon} (W + \frac{1}{2} w l).$$

From this value of  $f$  it will be seen that it is the same as if one-half of the pressure uniformly distributed had been concentrated at the middle point; and, by making  $w = 0$  and  $W = 0$ , respectively, in it, that the corresponding values of  $f$  obtained will be in the relations of 4 and 5 respectively to 1, as compared with  $f$  in the preceding cases.

Substituting in Eq. (10) for  $\mu$  its value,

$$\mu = \frac{1}{2} W l + \frac{1}{4} w l^2,$$

there obtains for the bending moment,

$$E \frac{d^2 y}{dx^2} = -\frac{W}{2} (l-2x) - \frac{1}{4} w (l^2 - 3x^2). \quad (a)$$

From an examination of this equation it will be seen that it is essentially negative for  $x = 0$ , and that as  $x$  increases its absolute value decreases, up to a value  $x'$  of  $x$  for which

$$-\frac{W}{2} (l-2x') - \frac{1}{4} w (l^2 - 3x'^2) = 0;$$

and which equation, solved with respect to  $x'$ , will give one positive root, comprised between the limits of  $\frac{1}{2} l$  and  $\sqrt{\frac{l^2}{3}}$ ; the first corresponding to  $w = 0$ , and the second to  $W = 0$ . With regard to the root  $x'$  of the preceding expression, as it corresponds to the value  $\frac{d^2 y}{dx^2} = 0$ , it shows that there will be a point of inflection in the curve corresponding to the abscissa  $x'$ ; and, beyond this point, that Eq. (a) changes its sign, and continues increasing in value; and, as the greatest negative value corresponds to  $x = 0$ , and greatest positive value to  $x = l$ , it will be seen, that since these values, which are respectively,

$$-\frac{1}{2} W l - \frac{1}{4} w l^2, \text{ and } \frac{1}{2} W l + \frac{1}{4} w l^2$$

are the one minus, the other plus, the greatest strains on the unit of area of the cross-sections will therefore be at B and D; the lower half of the cross-section being compressed at B, whilst that at D is in a state of tension.

The strains from the shearing force, at any cross-section, will arise from the two forces  $W$ , and  $w(l-x)$ ; and as the introduction of the moment  $\mu$  of the couple does not affect these values, it will have no effect on these strains which will be due alone to them.

S. *Beams supported at three points in the same right line, and acted upon by pressures distributed in any manner perpendicular to the mean fibre.*

When a rigid beam rests upon three or more supports, in the same right line, the ordinary rules of statics do not furnish the means of determining the amount of pressures, and consequent reaction, at each point of support, arising from pressures acting upon the beam; the problem in such a case being indeterminate.

Taking, for example, *Case 2* of a beam resting on two supports, and having a weight uniformly distributed along its length, it has been shown that each support bears one half the distributed load; and that the deflection of the mean fibre at the middle point, represented by  $f$ , is the same as the beam would take were  $\frac{2}{3}$ ths of the load acting alone at the middle point. Now, when the beam is in this condition, it is clear that the pressure upon a support, in contact with it at its middle point, would be zero; and if the support is raised so as to bring the middle of the beam into some position intermediate between **C** and **D**, the pressure on it would be a certain portion of the entire pressure, whilst each extreme support would be relieved of a certain corresponding portion of this pressure, and so on, until, the point of contact being brought in the same right line with the extreme supports, the intermediate support would evidently counteract the total pressure at **C** to which the deflection is due; which being  $\frac{2}{3}$ ths of the entire load, the reaction of the middle support would be equal to this. The two extreme supports, in like manner, would furnish a reaction equal to the remaining  $\frac{1}{3}$ ths, or  $\frac{1}{6}$ ths of the total load for each.

*Case 1.* (Fig. S.) *Beam resting on three points of support in the same right line dividing the length into two unequal segments.*

Let each segment, **A B**, **B C** be supposed to be strained by a

Fig. S

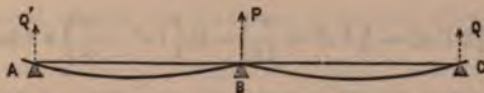

load uniformly distributed along its length, but of unequal intensity on the unit of length in the two.

Represent by

$2l'$  and  $2l$ , the respective lengths of **A B** and **B C**;

$w$ , and  $w'$ , the pressures on the unit of length of  $2l'$  and  $2l$  respectively;

$Q'$  and  $Q$ , the forces of reaction at **A** and **C**;

$P$ , the force of reaction at **B**;

$x$ ,  $y$ , the co-ordinates of any point in either segment referred to the rectangular co-ordinate axes having **B** for origin;

$\omega$ , the angle which the tangent to the curve at **B** makes with the axis of **X**.



In this case the forces of reactions,  $Q'$ ,  $Q$  and  $P$ , are among the quantities to be determined from the conditions of the question.

As the total load, or pressure  $2 w' l'$  and  $2 w l$ , on each segment respectively, may be regarded as acting at the middle point of the segment, and as their sum is equal to the sum of the forces of reaction; from the principles of statics, there obtains the relations,

$$\begin{aligned} Q' + Q + P &= 2 w' l' + 2 w l, \text{ (a)} \\ Q' \times 2 l' + 2 w l \times l &= Q \times 2 l + 2 w' l' \times l'; \text{ (b)} \end{aligned}$$

in which Eq. (a) expresses the relations of the sums of the forces; and Eq. (b) that between their moments with respect to the point B.

Referring to Eq. (6), *Case 2*, § r, there obtains, to express the relation between the moment of flexibility for any cross-section of the segment B C, at the distance  $x$  from B,

$$\epsilon \frac{d^2 y}{dx^2} = \frac{1}{2} w (2 l - x)^2 - Q (2 l - x); \text{ (1)}$$

integrating between the limits of  $x$ , and  $x = 0$ , and observing that for the latter limit,  $\frac{dy}{dx} = \tan. \omega$ ; and that the constant introduced by the integration becomes  $\epsilon \tan. \omega$ ; there obtains

$$\epsilon \frac{dy}{dx} = \frac{1}{2} w \left( 4 l x - 2 l x^2 + \frac{x^3}{3} \right) - Q \left( 2 l x - \frac{x^2}{2} \right) + \epsilon \tan. \omega; \text{ (2)}$$

integrating Eq. (2), there obtains

$$\epsilon y = \frac{1}{2} w \left( 2 l^3 x^2 - \frac{2}{3} l x^3 + \frac{x^4}{12} \right) - Q \left( l x^2 - \frac{x^3}{6} \right) + \epsilon \tan. \omega x, \text{ (3)}$$

for the equation of the curve of the mean fibre of the segment B C.

By simply changing  $w$ ,  $l$ ,  $Q$  to correspond to the notation for the segment A B, and  $+\epsilon \tan. \omega$  into  $-\epsilon \tan. \omega$ , in Eqs. (1), (2) and (3), the same relations will be obtained for the segment A B.

But since, for  $x = 0$  and  $x = 2 l$ ,  $y$  becomes zero, there obtains by the substitution of  $x = 2 l$  for the segment B C, and  $x = 2 l$  for the segment A B, the relations,

$$\begin{aligned} 0 &= 2 w l^3 - \frac{2}{3} Q l^3 + 2 \epsilon \tan. \omega l, \text{ (c)} \\ 0 &= 2 w' l'^3 - \frac{2}{3} Q' l'^3 - 2 \epsilon \tan. \omega l'. \text{ (d)} \end{aligned}$$

From Eqs. (a), (b), (c) and (d), by the ordinary process of elimination, the quantities  $P$ ,  $Q$ ,  $Q'$  and  $\tan. \omega$  can be readily found.

Supposing  $w = w'$  and  $l = l'$ ; then there obtains  $Q = Q'$ , and  $\tan. \omega = 0$ , since the two segments become symmetrical, and the tangent to the curve at **B** parallel to the axis of **X**. Making these substitutions in Eqs. (a) and (c), there obtains

$$\begin{aligned} 2 Q + P &= 4 w l, \text{ (a')} \\ 2 w l &= \frac{3}{8} Q l, \text{ (c')} \end{aligned}$$

By elimination between these two Eqs., there obtains

$$Q = \frac{3}{4} w l = \frac{3}{16} (4 w l), \text{ and } P = \frac{5}{8} (4 w l),$$

which are the same values as already given in the second paragraph of this section.

t. (Fig. T) *Beams resting upon any number of intermediate points of support between their two ends, having their segments uniformly loaded.*

The same processes, followed in the preceding sections, find their applications in the cases that fall under this section; the only difficulty being in the complex character of the solution. To avoid this, the expedient has been adopted, instead of finding the values

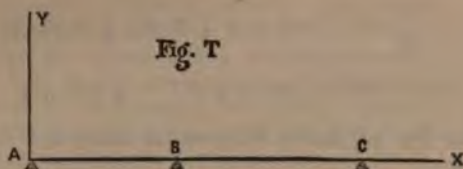

of the forces of reaction at the points of support directly, as in § 8, to use the bending moments taken with respect to the cross-sections at the points of support, as auxiliary unknown terms, and from these to determine the forces of reaction, and also the bending moments and shearing forces for any intermediate points between the supports.

Let **A B** and **B C** be any three of the consecutive points of support of a beam, all of which are in the same right line. Represent by

$l$  and  $l'$ , the segments **A B**, **B C**;

$w, w'$ , the pressures on the unit of length of  $l$  and  $l'$  respectively;

$X', X'', X'''$ , the bending moments for the cross-sections at **A**, **B** and **C** respectively;

$x, y$ , the co-ordinates of any point of the segment  $l$  referred to rectangular co-ordinates having **A** for origin.

Taking a cross-section at any point, at the distance  $x$  from the origin **A**, the weight uniformly distributed over the length  $(l - x)$

and its moment will be  $-\frac{1}{2} w (l - x^2)$ , estimating the direction of the rotation from  $A X$  towards  $A Y$  as positive. Then, in the expression of the bending moment for this point, there will enter this moment, and also the moments of all the other forces, arising from the reactions of the points of support, and the pressures distributed uniformly over the different segments, from  $A$  towards  $X$ ; the moments of which last forces will be expressed in terms containing the first degree of  $x$  only and constants; so that, definitely, the bending moment for this cross-section will be of the form  $A + Bx - \frac{1}{2} w x^2$ ; in which  $A$  and  $B$  are constants, to be subsequently found.

Taking then the general Eq. between the moment of flexibility and the bending moment, there obtains,

$$\varepsilon \frac{d^2 y}{dx^2} = A + Bx - \frac{1}{2} w x^2. (1)$$

Integrating between the limits of  $x$  and  $x = l$ , and representing by  $K'$  what  $\frac{dy}{dx}$  becomes for  $x = 0$ ; and by  $K''$  for  $x = l$ , in determining the value of the constants of integration, there obtains

$$\varepsilon \left( \frac{dy}{dx} - K' \right) = A x + \frac{1}{2} B x^2 - \frac{1}{6} w x^3. (2)$$

$$\varepsilon (K'' - K') = A l + \frac{1}{2} B l^2 - \frac{1}{6} w l^3. (3)$$

Integrating Eq. (2) again, between the limits  $x = 0$ , and  $x = l$ , there obtains

$$-\varepsilon K' = \frac{1}{2} A l + \frac{1}{6} B l^3 - \frac{1}{24} w l^4. (4)$$

Eliminating  $K'$  between Eqs. (3) and (4), there obtains

$$\varepsilon K'' = \frac{1}{2} A l + \frac{1}{6} B l^3 - \frac{1}{8} w l^3. (5)$$

By placing the origin of co-ordinates at  $B$ , the bending moment, for any cross-section in the segment  $BC$ , will, in like manner, take the form  $A' + B'x - \frac{1}{2} w' x^2$ , by using the same processes as in the segment  $AB$ ; and from these it will be seen, that there will be the relation, analogous to Eq. (4), shown by the expression,

$$\varepsilon K'' = \frac{1}{2} A' l' + \frac{1}{6} B' l'^3 - \frac{1}{24} w' l'^4. (6)$$

Eliminating  $K''$  between Eqs. (5) and (6), there obtains

$$\frac{1}{2} A l + \frac{1}{2} A' l' + \frac{1}{6} B l^3 + \frac{1}{6} B' l'^3 - \frac{1}{2} w l^3 - \frac{1}{24} w' l'^4 = 0. (7)$$

Now the quantities  $A, B, A', B'$ , can be expressed in terms of  $X, X'', X'''$ ; for the function  $A + Bx - \frac{1}{2} w x^2$  should have the same

values as  $X$  and  $X''$ , for  $x = 0$  and  $x = l$ ; making these substitutions for  $x$  in this function, there obtains

$A = X'$  for  $x = 0$ ; and  $A + B l - \frac{1}{2} w l^2 = X''$ , for  $x = l$ .  
Hence

$$A = X', \text{ and } B = \frac{1}{2} w l + \frac{X'' - X'}{l}. \quad (\text{a})$$

In like manner,

$$A' = -X'', \text{ and } B' = \frac{1}{2} w' l' + \frac{X''' - X''}{l'}. \quad (\text{b})$$

Substituting these values of  $A, B, A', B'$  in Eq. (7), there obtains

$$\frac{1}{2} X' l + \frac{1}{2} X'' (l + l') + \frac{1}{2} X''' l + \frac{1}{24} w l^3 + \frac{1}{24} w' l'^3 = 0; \\ \text{nence,} \\ X' l + 2 X'' (l + l') + X''' l + \frac{1}{2} (w l^3 + w' l'^3) = 0; \quad (\text{c})$$

which expresses the relation between the bending moments for any three consecutive points of support.

This striking theorem furnishes the means of obtaining the relations between the bending moments for any number of cross-sections on consecutive points of support. Supposing  $n + 1$  to be the number of consecutive supports, represented by  $A_0, A_1, A_2, \dots, A_{n-2}, A_{n-1}, A_n$ ; and the corresponding bending moments by  $X_0, X_1, X_2, \dots, X_{n-1}, X_n$ . It will be apparent, in the first place, that from the conditions of the problem, the bending moments  $X_0$  and  $X_n$  of the two extremities must be zero; and that, therefore, the quantities alone to be determined will be from  $X_1$  to  $X_{n-1}$ , or  $n - 1$  unknown terms. To find these it will only be necessary to apply Eq. (c) successively to each consecutive pair of segments to obtain the number of equations from which, by successive elimination,  $X_1, X_2, \dots$ , can be found.

Having, in this manner, determined the bending moments  $X_1$  for the corresponding points of support; that for any point, between two supports, of an intermediate segment, can be found; and the equation between it and the moment of flexibility be deduced; by determining, from Eq. (a), the values of  $A$  and  $B$  corresponding to this segment, and substituting them in Eq. (1). The final equation determined by integrating the equation twice, will give the relations between  $x$  and  $y$  of the curve of the mean fibre in this segment.

*Applications of Formula (c).*—This formula can be applied, first to find the bending moments at the points of support; and second, from their values to deduce the pressures or reactions at those points.

*Case 1. Beams resting on three points of support at equal distances apart.*—This case, which has already been considered, is repeated here to compare more directly this method with the one treated in § 8. In this case, the quantities represented by  $l, l', w,$

$w$ , Eq. (c) become respectively  $2l$  and  $w$ ; and  $X', X''$  are each zero. Making these changes, there obtains,

$$2X''(2l + 2l) + \frac{1}{4}(8wl^2 + 8w^2l^2) = 0, \text{ or } 8X''l + 4w^2l^2 = 0$$

hence  $X' = -\frac{1}{4}w^2l$ .

But from Ec. (1), § 8, making  $x = 0$ , the value of the bending moment for the intermediate point of support is  $2Ql - 2w^2l^2$ , by changing the signs of both members of the equation to conform to the foregoing value of  $X'$ . Equating these two values of the bending moment, there obtains,

$$2Ql - 2w^2l^2 = -\frac{1}{4}w^2l^2, \text{ hence } Q = \frac{3}{8}w^2l = \frac{3}{16}(4w^2l),$$

which is the same value as before found.

*Case 2. Beam resting on four points of support, the two extreme segments being equal and the middle one unequal to either of the others.*

Fig. U



Let  $A, B, C, D$  (Fig. U) be the four points of support; the segment  $AB = CD$ . Represent the segments  $AB, CD$  by  $l$ , and  $BC$  by  $n l$ ; by  $w_1, w_2, w_3$  the pressures on the units of length on the segments  $AB, BC, CD$  respectively.

First, to find the bending moments,  $X_1, X_2$ , for the cross-sections at  $B, C$  there obtains from Form. (c), for the segments  $AB, BC$ ,

$$2X_1(l + n l) + X_2 n l + \frac{1}{4}(w_1 l^2 + w_2 n^2 l^2) = 0, \text{ (x)}$$

as  $X_0 = 0$ ; and for segments  $BC, CD$ ,

$$X_1 n l + 2X_2(l + n l) + \frac{1}{4}(w_2 n^2 l^2 + w_3 l^2) = 0, \text{ (y)}$$

as  $X_3 = 0$ .

Eliminating between Eqs. (x), (y), there obtains,

$$X_1 = \frac{l^2}{4(2+n)(2+3n)} [n w_2 - n^2(2+n) w_2 - 2(1+n) w_3] \text{ (m)}$$

$$X_2 = \frac{l^2}{4(2+n)(2+3n)} [n w_1 - n^2(2+n) w_2 - 2(1+n) w_3] \text{ (n)}$$

Taking now the general expression for the bending moment,  $X$ , at any point of the segment  $CD$ , which is of the form,

$$X = a + \beta x - \frac{1}{2} w_3 x^2,$$

and determining the values of  $a$  and  $\beta$ , as in Eqs. (a), (b); and

making  $X = 0$ , for  $x = 0$ ; and  $X = X_2$ , for  $x = l$ ; the values of  $x$  being estimated from **D**, there obtains

$$a = 0, \text{ and } \beta l - \frac{1}{2} w_2 l^2 = X_2;$$

which substituted in the preceding expression, there obtains

$$X = \left( \frac{X_2}{l} + \frac{1}{2} w_2 l \right) x - \frac{1}{2} w_2 x^2. \quad (o)$$

In like manner, for the segment **CB**, estimating the  $x$ 's from **C**, the general value of  $X$  takes the form

$$X = a' + \beta' x_1 - \frac{1}{2} w_2 x_1^2;$$

determining  $a'$  and  $\beta'$  from the conditions that for  $x = 0$ ,  $X = X_2$ , and for  $x_1 = n l$ ,  $X = X_1$ ; there obtains, after eliminating  $a'$ ,  $\beta'$ ,

$$X = X_2 + \left( \frac{X_1 - X_2}{n l} + \frac{1}{2} w_2 n l \right) x_1 - \frac{1}{2} w_2 x_1^2. \quad (p)$$

For the segment **AB**, estimating the  $x$ 's from **A**, by a simple change of the notation, placing  $X_1$  for  $X_2$ , and  $w_1$  for  $w_2$ , in the value for  $X$  for the segment **CD**, there obtains

$$X = \left( \frac{X_1}{l} + \frac{1}{2} w_1 l \right) x_2 - \frac{1}{2} w_1 x_2^2. \quad (q)$$

Now the object of the proposition may be, either to find the reaction at the points of support as in *Case 1*; or to find the strain on the unit of area at any cross-section. In the first case, the mode of proceeding will be the same as in *Case 1*. The bending moment, arising from the force of reaction regarded as unknown, and from the total force distributed over the first segment which is known, must be placed equal to the bending moment as given in the Eq. (m), and from the resulting equation the force of reaction can be found. In like manner, the difference between the moments of the forces of reaction at **A** and **B**, and of the total forces on the two segments, **AB**, **BC**, must be placed equal to the bending moment given in Eq. (n), to find the force of reaction at **B**. The same processes must be followed for the two segments **DC**, **CB**.

In the second case, to find the strain on the unit of area for any cross-section, in either segment, the Eqs. (o), (p), (q) must be used, as in *Cases 2, 3*, § r.

*Case 3. To determine the reactions at the points of support in a beam uniformly loaded on each unit of length and resting on five points of support at equal distances apart.*

Let **A, B, C, D, E**, (Fig. V) be the five points of support. Represent by

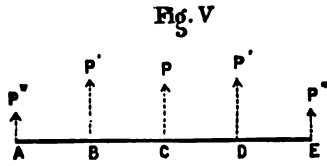

Fig. V

$l$ , the equal distances **A B, B C**, etc.;  
 $w$ , the weight on the unit of length;  
 $P$ , the force of reaction at the middle point **C**;  
 $P', P'$ , the equal forces of reaction at the point **B, D**;  
 $P'', P''$ , the same at the extreme points **A, E**;

$X', X''$ , the bending moments at **B** and **C**.

Resuming Eq. (c) and applying it successively to the segments, **A B, B C**, and **B C, C D**, there obtains for the two first

$$2 X' (l + l) + X'' l + \frac{1}{2} (w l^2 + w l^2), \text{ or } 4 X' + X'' + \frac{1}{2} w l^2 = (0); \text{ and for the two } B C, C D,$$

$$X' + 2 X'' + \frac{1}{2} w l^2 = 0;$$

and by elimination,

$$X' = -\frac{3}{8} w l^2, \text{ and } X'' = -\frac{1}{4} w l^2.$$

Now, for the segment **A B**, the forces acting upon it, to produce deflection, are the force of reaction at **A** which is  $P''$ , and the weight  $w l$  uniformly distributed over the segment; from this there obtains, as in the preceding cases,

$$P'' l - \frac{1}{2} w l^2 = + X' = -\frac{3}{8} w l^2. \therefore P'' = \frac{1}{8} w l = \frac{1}{16} (4 w l).$$

For the segment **B C**, the forces producing deflection are the two forces of reaction  $P'', P'$ , acting with the respective arms of lever  $2 l$  and  $l$ ; and the two equal weights  $w l$ , the one acting with the arm of lever  $\frac{3}{2} l$ , and the other with the arm of lever  $\frac{1}{2} l$ , hence

$$P''. 2 l + P' l - \frac{3}{2} w l^2 - \frac{1}{2} w l^2 = + X'' = -\frac{1}{4} w l^2;$$

hence, substituting for  $P''$ , and reducing,

$$P' = \frac{3}{8} w l = \frac{3}{16} (4 w l).$$

Having determined  $P''$  and  $P'$ , there obtains, since the sum of the forces of reaction is equal to the entire load,

$$P + 2 P'' + 2 P' = 4 w l. \therefore P = \frac{1}{2} (4 w l).$$

*Case 4. Suppose that the beam is uniformly loaded and resting on  $n$  points of support at equal distances apart.*

Let  $l$  = one of the equal distances,

$w$  = the load on a unit of length,

$X_0, X_1, X_2, \text{ etc.}$ , be the bending moments over the supports,

$V_0, V_1, V_2, \text{ etc.}$ , be the reactions of the supports, and

$n$  = the number of supports.

If  $n$  be even the reaction of the  $\frac{1}{2}n^{\text{th}}$  and  $(\frac{1}{2}n + 1)^{\text{th}}$  supports will be equal, and if  $n$  be odd the  $\frac{1}{2}(n + 1)$  will be the middle support, and the reaction of the supports equidistant from the middle will be equal.

In this case Eq. (c) becomes when  $n$  is even,

$$\begin{aligned} X_0 + 4 X_1 + X_2 + \frac{1}{2} w l^2 &= 0 \\ X_1 + 4 X_2 + X_3 + \frac{1}{2} w l^2 &= 0 \\ X_2 + 4 X_3 + X_4 + \frac{1}{2} w l^2 &= 0 \\ \dots & \dots \\ X_{\frac{1}{2}n-2} + 4 X_{\frac{1}{2}n-1} + X_{\frac{1}{2}n} + \frac{1}{2} w l^2 &= 0 \\ X_{\frac{1}{2}n-1} + 4 X_{\frac{1}{2}n} + X_{\frac{1}{2}n+1} + \frac{1}{2} w l^2 &= 0 \end{aligned}$$

In this case  $X_0 = 0$ . When  $n$  is known  $X_1, X_2$ , etc., become completely known, after which  $V_0, V_1$ , etc., may be found.

To find the inclination of the curve at the ends for any number of supports, we begin with the general equation of moments, which in this case becomes

$$\varepsilon \frac{d^2 y}{dx^2} = -V_0 x + \frac{1}{2} w x^2.$$

Integrating once gives

$$\varepsilon \frac{dy}{dx} = -\frac{1}{2} V_0 x^2 + \frac{1}{6} w x^3 + C_1,$$

Integrating again gives

$$\varepsilon y = -\frac{1}{6} V_0 x^3 + \frac{1}{24} w x^4 + C_1 x + C_2$$

But  $y = 0$  for  $x = 0 \therefore C_2 = 0$ ,

Also  $y = 0$  for  $x = l \therefore C_1 = \frac{1}{6} V_0 l^3 - \frac{1}{24} w l^4$

Hence  $\varepsilon \frac{dy}{dx} = \frac{1}{6} V_0 (l^3 - 3x^2) + \frac{1}{24} w (4x^3 - l^3)$

And  $\varepsilon y = \frac{1}{6} V_0 (l^3 x - x^3) + \frac{1}{24} w (x^4 - l^3 x)$ .

At the first support  $x = 0$ , and  $\frac{dy}{dx} = \text{tang. } i$

$$\therefore \text{tang. } i = \left[ 4 V_0 - w l \right] \frac{l^3}{24 \varepsilon}$$

At the middle of the first space  $x = \frac{1}{2} l$ , and the deflection at that point is

$$y = \Delta = \left[ 24 V_0 - 7 w l \right] \frac{l^4}{384 \varepsilon}$$

u. *Application of the theorems in the preceding sections to esti*



making the effect of the external forces in producing strains on the parts composing a frame.

Every part of a frame may be subjected either to a direct strain of compression, or extension, from an external force acting in the direction of the fibres; to a strain on the fibres by a force acting perpendicular to them; or to one arising from a force acting obliquely to the fibres so as to produce simple deflection, and either direct extension, or compression.

The forces themselves may be classified under two heads. 1st. Those which are directly applied to certain points. 2d. Those which are transmitted, from the points of application of the first, through the intermedium of parts of the frame to other points, and which, from the relationship of the parts of the frame to each other, can be found, by the laws of statics, when the first are given, or can be determined, as in the cases just examined of reactions.

The problems, therefore, which present themselves for solution in this section, are to find the directions and intensities of the forces acting on each piece; and to determine from them the form and dimensions of the cross-section of each, so that the strain on the unit of surface shall at no point be greater than the limit allowed for safety.

*Case 1. (Fig. W.) Beam resting at the lower end upon a horizontal support, and at the upper against a vertical surface, and strained by a weight applied at its middle point.*

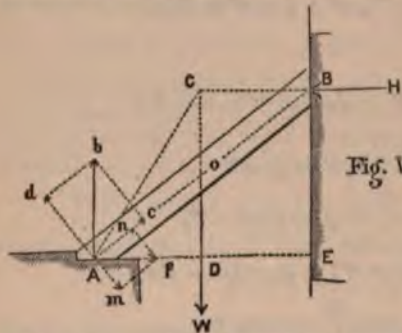

Fig. W

Let  $AB$  be the axis of the beam;  $O$  the middle point where the weight  $W$  is applied. Represent by  $l$ , the length  $AB$ ; by  $\alpha$ , the angle between  $AB$  and the vertical line through  $O$ ;  $H$ , the horizontal force of reaction at the point  $B$  where the beam rests against the vertical surface, and which is equal and contrary to a corresponding horizontal reaction at the point  $A$ ,

arising from a shoulder which prevents the lower end from moving outwards.

As the couple  $H, -H$  tends to turn  $AB$  in a direction contrary to the action of  $W$ , from the conditions of equilibrium their moments must be equal, hence

$$H \times CD = W \times AD.$$

But  $CD = BE = l \cos. \alpha$ ; and  $AD = \frac{1}{2} AE = \frac{1}{2} l \sin. \alpha$ ; and substituting these values in the preceding expression, there obtains

$$H l \cos. \alpha = W \frac{1}{2} l \sin. \alpha, \therefore H = \frac{1}{2} W \tan. \alpha.$$

The beam therefore is subjected at its lower end to the force of vertical reaction  $W$ , and one of horizontal reaction  $H$ .

Now representing the force  $W$ , by the line  $A b$ ; and the one  $H$  by the line  $A p$ ; and constructing the parallelograms of forces, on these two lines respectively as resultants, having the components perpendicular and parallel to  $A B$ ;  $A d$  and  $A m$  will be the perpendicular components of  $A b$  and  $A p$ , and  $A c$ ,  $A n$  the parallel components. Finding the values of these components from the diagram, there obtains

$$A d = W \sin. \alpha, A c = W \cos. \alpha; A m = \frac{1}{2} W \tan. \alpha \cos. \alpha, A n = \frac{1}{2} W \tan. \alpha \sin. \alpha.$$

The two perpendicular components, it will be seen, act in a contrary direction, and therefore the strain on the fibres, arising from simple deflection, will be due to their difference; whilst the components along  $A B$  acting in the same direction will produce a direct strain of compression on the fibres due to their sum.

The greatest value for the bending moment will evidently be for the cross-section of the beam at  $O$  where the weight  $W$  acts. Therefore to express its value for this point, there obtains

$$(W \sin. \alpha - \frac{1}{2} W \tan. \alpha \cos. \alpha) \frac{1}{2} l = \frac{1}{4} W \sin. \alpha l.$$

Supposing the cross-section of the beam to be a rectangle, and representing the side in the direction in which  $W$  acts by  $d$ , and the breadth by  $b$ , there obtains, §  $q$ , for the limit of the strain on the unit of area at the extreme fibre, due to the deflection

$$R' = \frac{\frac{1}{4} W \sin. \alpha l}{\frac{1}{2} b d^2} = \frac{3}{4} W \sin. \alpha \frac{l}{b d^2}$$

For the strain on the unit of surface from the direct compression arising from the sum of the parallel components, there obtains

$$R'' = \frac{W \cos. \alpha + \frac{1}{2} W \tan. \alpha \sin. \alpha}{b d}$$

Now taking the sum  $R' + R''$ , the limit  $R'''$  of the strain on the unit of area must be less than this sum, or

$$R''' < R' + R''.$$

In the preceding example, as in the following in this section, the relative dimensions of the lengths of the beams and their cross-section are supposed to be such that  $f$ , or the greatest ordinate of the curve of the mean fibre, arising from the deflection, may be regarded

as so small that the direction of the components of the external forces parallel to this fibre shall deviate so slightly from a right line that it may be regarded as such. In any other case the moment of the algebraic sum of these components would have to be added to the moment of the algebraic sum of the perpendicular components to obtain the bending moment. In practice it is seldom that this is necessary, as the amount of deflection allowed is always very small.

*Case 2. (Fig. X.) Beam having one end solidly fixed and supported at some intermediate point between the two ends, either by another inclined beam below, or by a bar above it, to sustain the action of a weight at the other end.*

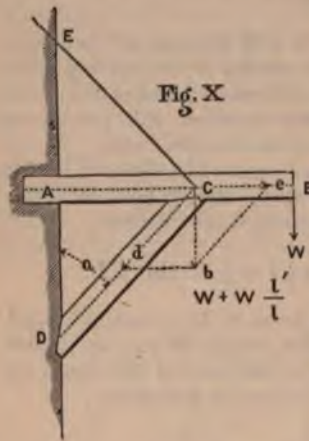

Let  $AB$  be the projecting portion of the beam,  $C$  the intermediate point to which a beam  $DC$ , or a bar  $EC$  is attached.

Represent by  $W$ , the weight acting at  $B$  perpendicular to  $AB$ ;  $AC = l$  and  $BC = l'$  the lengths of the two segments;  $\alpha$ , the angle  $ADC$ .

The beam being held in its position and prevented from turning around  $C$  by the downward vertical reaction at the point  $A$ . Representing this force of reaction by  $W'$ , there obtains, from the theorem of parallel forces,

$$W' l = W l', \therefore W' = \frac{W l'}{l};$$

and for the resultant of  $W$  and  $W'$  which acts through the point  $C$ ,

$$W + W \frac{l'}{l} = W \frac{l + l'}{l}.$$

Representing this resultant by the line  $Cb$ , and constructing the parallelogram of forces in the directions  $CB$ ,  $CD$  of the axes of the beams, there obtains

$$Ce = W \frac{l + l'}{l} \tan. \alpha; \quad Cd = W \frac{l + l'}{l \cos. \alpha}$$

Taking the segment  $AC$ , it will be seen that its fibres will be strained by the force  $W \frac{l'}{l}$ , acting at  $A$  to produce simple deflec-

tion; and by the force  $W \frac{l+l'}{l} \tan. \alpha$ , acting in the direction  $C e$ , to produce direct extension. The limits of the strains on the unit of area of the cross-section as a rectangle, in which  $d$  and  $b$  represent the sides, as in the preceding case, will be,

$$R' = \frac{W \frac{l'}{l}}{\frac{1}{2} b d}, \text{ and } R'' = \frac{W \frac{l+l'}{l} \tan. \alpha}{b d};$$

and for  $R''' < R' + R''$ ,

$$R''' < \frac{6 W l'}{b d^2 l} + W \frac{l+l'}{b d l} \tan. \alpha.$$

As the strain on the lower beam is direct compression, there obtains for this limit,

$$R'' < \frac{W (l+l')}{b' d' \cos. \alpha l}$$

in which  $b'$  and  $d'$  are the sides of the rectangular cross-section.

Like expressions would be found for the bar, the directions of the direct strains being reversed. Those on the segment  $A C$  being compressions, and those on the bar extensions.

*Case 3. (Fig. Y.) Strains on the parts of a frame of three beams arising from a pressure at one of the angular points, or from pressures uniformly distributed over the lengths of two of the parts.*

In this combination the beams are united at the angular points by some of the usual joints for such purposes.

Suppose, in the first place, the beam  $B C$  to be horizontal, and to rest on two fixed supports at  $B, C$ , and the pressure at  $A$  to arise from a weight  $W$ .

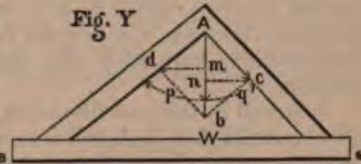

Setting off from  $A$  the length  $A b$  along a vertical line, to represent the weight  $W$ ; constructing on this line, as a resultant, the parallelogram of forces, having the components  $A d, A c$ , in the directions of the two beams  $A B, B C$ ; and denoting the angles between  $A b$  and its two components by  $p$  and  $q$ , there obtains

$$A d = W \frac{\sin. q}{\sin. (p + q)}; \quad A c = W \frac{\sin. p}{\sin. (p + q)}.$$

If, from  $d$  and  $c$ , two lines  $d m, c n$  be drawn perpendicular to

$A b$ , they will be equal, and will represent the horizontal pressure or reaction of the beams at the point  $A$ , which is expressed by

$$d m = c n = \frac{\sin. p \sin. q}{\sin. (p + q)} W.$$

Now as the pressures, represented by the components  $A d$ ,  $A c$ , are transmitted through the beams to the points  $B$  and  $C$  respectively, they can each be resolved into two components, one vertical which will be counteracted by the points of support  $B, C$ ; and one horizontal, counteracted by the resistance offered by the beam  $BC$ .

The vertical component at  $B$  is evidently equal to  $A m$ , and the one at  $C$  to  $A n$ ; the horizontal components at  $B$  and  $C$  are each equal to  $d m = c n$ . From the diagram there obtains

$$A m = W \frac{\sin. q \cos. p}{\sin. (p + q)}; \quad A n = W \frac{\sin. p \cos. q}{\sin. (p + q)};$$

for the vertical components, or pressures on the points of support.

When the angles,  $p$  and  $q$  are equal, there obtains

$$A d = A c = \frac{1}{2} \frac{W}{\cos. p}; \quad d m = c n = \frac{1}{2} W \tan. p; \quad A m = A n = \frac{1}{2} W.$$

The strains on  $AB, AC$  will be compressions; and that on  $BC$  extension. Their limit on the unit of area will be determined as in the preceding cases for direct compression or extension; which values, however, would be true only under the supposition that the relations between the lengths  $AB, AC$  and the areas of their cross-sections were such that there would be no strain from deflection.

It is well in this and like cases, for convenience, to note, that the two triangles  $A d b, A c b$  into which the parallelogram is divided by  $A b$ , are similar to the triangle  $BAC$ ; that the perpendiculars  $d m, c n$  divide  $A b$  into segments which are respectively proportional to the two segments into which  $BC$  is divided by  $A b$  prolonged; and that in the resolution of either component of  $A b$ , as  $A d$  for example, at any point, as  $B$ , on its line of direction, into components perpendicular and parallel to  $A b$ , the two components will be respectively  $d m$ , and  $A m$ , which is the segment of  $A b$  between  $A$  and  $d m$ .

In the case of an equal pressure,  $w$ , on each unit of length of  $AB, AC$ , represented by  $l, l$  respectively, each beam may be regarded as in *Case 1*; the strains arising from the vertical pressures  $w l$  and  $w l'$  acting at the middle points of the beams.

*Case 4. (Fig. Z.) Roof truss framed with struts and king-post.*

The strains on the different parts in this and like cases are usually due to a weight uniformly distributed along the rafters, in which may be included the weight of each rafter.

The struts **E D**, **F D** are intended to diminish the amount of deflection of the rafters, keeping the middle point of each in the same right line as the two ends. Each rafter therefore will be in the condition of a beam resting on three supports in a right line, in which  $\frac{5}{8}$ ths of the component of  $w l$  perpendicular to the rafter will act at the middle point, and  $\frac{3}{16}$ ths at each end.

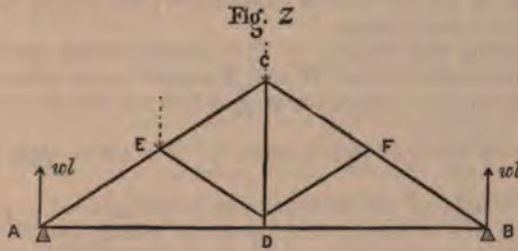

Representing by  $l$  the length **A C**, **B C** of the rafters; by  $w$  the weight on the unit of length; and by  $\alpha$ , the angle **C A B** between each rafter and the tie-beam **A B**; then the normal pressure at the middle point of each rafter will be  $\frac{5}{8} w l \cos. \alpha$ , and that at each end  $\frac{3}{16} w l \cos. \alpha$ . The components parallel to or along the rafters will produce direct compression.

*Pressure on the Struts.*—This pressure will arise from  $\frac{5}{8} w l \cos. \alpha$ . Representing by  $\beta$  the angle between the strut and rafter, and by **P** the pressure in the direction of the strut, the component of **P** perpendicular to the rafter must be equal to the normal pressure on the rafter, or,

$$P \sin. \beta = \frac{5}{8} w l \cos. \alpha. \therefore P = \frac{5}{8} w l \frac{\cos. \alpha}{\sin. \beta}$$

*Tension on king-post.*—This tension arises from the downward pull of the pressure **P** on each strut, which is transmitted to the lower end of the king-post, and from the weight of the tie-beam.

As each strut makes an angle  $(\beta - \alpha)$  with the tie-beam, the component of **P** along the king-post will be  $P \sin. (\beta - \alpha)$ , and as the king-post prevents deflection of the tie-beam at the middle point, the additional pull on the part of the king-post above the lower end of the struts will be  $\frac{5}{8} W'$ ; in which  $W'$  represents the weight of the tie-beam. Therefore calling the total pull **T**, there obtains,

$$T = \frac{5}{8} W' + 2 P \sin. (\beta - \alpha).$$

*Vertical reaction of the points of support on the foci of each rafter from the weight of the roof-covering and tie-beam.*

Representing by  $W$  the vertical reaction at  $A, B$ ,  $2W$  will evidently be equal to the sum of  $2wl$  the weight of the roof-covering, and of  $\frac{5}{8}W'$  which is the pull on the king-post from the weight of the tie-beam transmitted to the junction  $C$  of the rafters; there obtains to express the equality

$$2W = 2wl + \frac{5}{8}W'. \therefore W = wl + \frac{5}{16}W'.$$

*Tension on the tie-beam.*—The forces applied to the foot of each rafter at  $A, B$ , are the vertical reactions  $W$ , the weight  $\frac{3}{16}wl$ , and the tension on the tie-beam.

Representing this tension by  $T$ , it is evident that the difference between the components of  $W$  and  $T$  normal to the rafter must be equal to the normal component of  $\frac{3}{16}wl$ ; from this there obtains

$$W \cos. \alpha - T \sin. \alpha = \frac{3}{16}wl \cos. \alpha. \therefore T = (W - \frac{3}{16}wl) \tan. \alpha.$$

When the weight of the tie-beam may be disregarded in producing deflection it will be subjected to the strain arising from  $T$  alone.

From the preceding expressions, the values of  $T$  and  $T'$  can be obtained by substituting for the values of  $P$  and  $W$  respectively.

The strains on each segment of the rafter  $AC$ , for any cross-section, will arise from the forces acting normally to the segments at  $A$  and  $C$  which produce deflection, and from the forces acting along the rafter producing compression at the cross-section. These can be readily found in a similar manner to *Case 1*.

Having found the amount of strain for each piece of the frame, the limit of the strain on the unit of area of the cross-section can be determined in the usual way.

*Case 5. (Fig. A'.) Roof truss in which the rafters are divided into three equal segments, and supported at the points of division by struts, the lower ends of which are supported by a king or queen-post.*

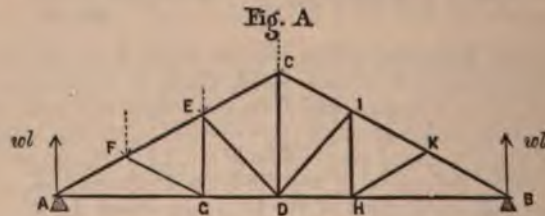

Let  $AF, FE, EC$  be the three equal segments;  $FG, ED$  the two struts supporting the points  $F, E$ , and supported at their lower ends by the queen and king-posts,  $EG, CD$ .

The more usual manner of determining the amount of strain on each part of the truss is to consider it as composed of several secondary triangular frames or trusses in which the piece common to any two of the secondary trusses, as a strut or tie-beam, for example, is subjected to the strains arising from the compressions or extensions brought upon it from the forces acting on the parts with which it is connected.

Taking the half  $A C D$  of the primary  $A C B$ , it may be regarded as composed of the secondary trusses  $A F G$ ,  $A E D$ ,  $E C D$ ; in which the strut  $F G$ , and the segment  $A G$  of the tie-beam form parts of the two first, etc.

As each of the equal segments of the rafter bears one-third of the weight, or  $\frac{1}{3} w l$ , uniformly distributed over it, and is supported at its two ends, the support of each end will sustain one-half of this third or  $\frac{1}{6} \cdot \frac{1}{3} w l = \frac{1}{6} w l$ . In this way the supports  $A$ ,  $C$ , bear directly  $\frac{1}{6} w l$ ; and the two  $F$ ,  $E$  bear  $\frac{1}{3} w l$ .

Now each of these triangular frames may be regarded, as in *Case 3*, as acted upon by a vertical force at its vertex, the effect of which is to produce a direct compression on the two sides, and extension on the base. To find the amount of these for  $A F G$ , construct the parallelogram of forces having  $\frac{1}{6} w l$  for the resultant, and the components in the directions  $F A$ ,  $F G$ . Representing by  $\alpha$  the angle  $F A G$ , these components, as the triangle  $A F G$  is isosceles, will be equal, and each equal to  $\frac{1}{6} \frac{w l}{\sin \alpha}$ . These components exert compressions on  $F A$ ,  $F G$ , which are transmitted to the points  $A$  and  $G$ .

Here the first is sustained by the vertical reaction of the point of support, and that of the segment of the tie-beam  $A G$ . To find these reactions, resolve  $\frac{1}{6} \frac{w l}{\sin \alpha}$  at  $A$  into two components, one vertical, the other horizontal. The first will be  $\frac{1}{6} w l$ ; the second  $\frac{1}{6} w l \cot \alpha$ . By a like process, the vertical and horizontal components of  $\frac{1}{6} \frac{w l}{\sin \alpha}$  at  $G$  will be  $\frac{1}{6} w l$  which is sustained by the queen-post  $E G$  and transmitted through it to the point  $E$ , thus producing direct extension on the queen-post  $\frac{1}{6} w l \cot \alpha$ ; and the horizontal component will be equal and opposite to the one at  $A$ , and will produce direct extension on the segment  $A G$  of the tie-beam.

For the second truss  $A E D$ , there will be a direct force  $\frac{1}{6} w l$ , and the transmitted force  $\frac{1}{6} w l$ , or  $\frac{1}{6} w l + \frac{1}{6} w l = \frac{1}{3} w l$  acting at  $E$ . This resolved in the directions  $E A$ ,  $E D$ , will give  $\frac{1}{3} \frac{w l}{\sin \alpha}$  for

the component along  $E A$ , and  $\frac{1}{3} \frac{w l}{\sin \angle E D G}$  for that along  $E D$

These two components are transmitted, through the rafter and strut respectively, to the points  $A$ ,  $D$ , and are there counter



acted by the reactions of the support **A**, and the tie-beam on the one hand, and by those of the king-post **C D** and the tie-beam on the other. The extension on the tie-beam will be  $\frac{1}{2} w l \tan. \alpha$ ; the vertical pressure at **A**,  $\frac{1}{2} w l$ ; and the pull on the king-post  $\frac{1}{2} w l$ .

For the half **A C D** of the primary truss, there is a direct force  $\frac{1}{2} w l$ , and the transmitted force  $\frac{1}{2} w l$ , or  $\frac{1}{2} w l + \frac{1}{2} w l = \frac{1}{2} w l$  acting at **C**. This resolved at **C** in the direction **C A** and perpendicular to the direction  $\frac{1}{2} w l$ , gives for the first  $\frac{1}{2} \frac{w l}{\sin. \alpha}$  and  $\frac{1}{2} w l \cot. \alpha$ . This last component is equal and contrary to the like component of  $\frac{1}{2} w l$ , for the other half **B C D** of the primary truss.

From this method of considering the connection of the secondary trusses with each other, and with the primary truss, and the pressures to which they are subjected, it will be seen that the segment **A F** of the secondary truss, **A F G**, will be strained by the pressure at **F**, and by those on the segments **F E**, **E C** of the rafter; and the segment **A G** of the tie-beam by those on **G D**, by which it is connected with **A E D** and **A C D**. In like manner the strains on the parts, **E F**, **G D**, which connect the secondary truss **A E D** with the primary, will arise from the pressures at **E** and **C**. Adding together these different forces, there obtains

$$\frac{1}{2} \frac{w l}{\sin. \alpha} + \frac{1}{2} \frac{w l}{\sin. \alpha} + \frac{1}{2} \frac{w l}{\sin. \alpha} = \frac{3}{2} \frac{w l}{\sin. \alpha}, \text{ for the compression of the segment } \mathbf{A F}.$$

$$\frac{1}{2} \frac{w l}{\sin. \alpha} + \frac{1}{2} \frac{w l}{\sin. \alpha} = \frac{1}{2} \frac{w l}{\sin. \alpha}, \text{ for the compression on the segment } \mathbf{F E}.$$

$$\frac{1}{2} \frac{w l}{\sin. \alpha} = \frac{1}{2} \frac{w l}{\sin. \alpha}, \text{ for the compression on } \mathbf{E C}.$$

In like manner the tension on the segment **A G** of the tie-beam will be found equal to  $\frac{3}{2} w l \cot. \alpha$ ; and that on the segment **G D**,  $\frac{1}{2} w l \cot. \alpha$ , as this segment forms a part both of the secondary truss **A E D** and of the primary.

*Case 6. (Fig. B'.) Roof trusses of wrought and cast-iron.*

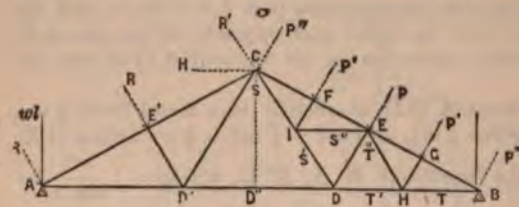

In these combinations the rafters of the truss are of wrought-iron of a **T** or **I** cross-section; the struts of cast-iron, and the tie-beams

and rods of wrought-iron, of round or rectangular cross-section.

In ordinary spans the rafters are supported by a single strut, as at **E' D'**, which prevents the deflection at the middle point, by the

reaction of the two tie-rods  $A D'$ ,  $C D'$ , to which the lower end of the strut is fastened. When the length of the rafter is so great that one strut would not give sufficient stiffness, two intermediate struts are inserted, dividing the rafter into four equal segments; the intermediate, like the main strut, being held in place by tie-rods.

In the first combination there will be one secondary truss only, as shown in the left half of the Fig. In the second, there will be three secondary trusses; but each of the two smaller ones, being connected only with the larger secondary and the primary, will be affected only by the pressures on these two.

Taking the case of a single strut, represent by  $w$ , as in the preceding cases, the weight on the unit of length of the rafter;  $l$ , its length;  $\alpha$ , the angle  $C A B$ ;  $H$ , the horizontal reaction of the rafters at the point  $C$ ;  $R$ , the pressure on the strut  $E' D'$ ;  $T$ , the tension on the tie-rod  $A D'$ ;  $S$ , the tension on  $C D'$ .

Leaving out of consideration the weights of the strut and tie-rods, as small in comparison with  $w l$ , the weight of the rafters and roof-covering,  $w l$  may be taken as acting through the middle point  $E'$  of  $A C$ , and its moment therefore will be equal to the moment of the couple  $H, -H$ , at  $C$  and  $A$ . From this there obtains

$$w l \cdot \frac{1}{2} A D'' = H \cdot C D'.$$

or, placing for  $\frac{1}{2} A D''$  and  $C D'$ , their values  $\frac{1}{2} l \cos. \alpha$ ,  $l \sin. \alpha$ ,

$$\frac{1}{2} w l^2 \cos. \alpha = H l \sin. \alpha. \therefore H = \frac{1}{2} w l \cot. \alpha.$$

Considering the rafter as a single beam, calling  $R$  the normal pressure at the point  $E'$ , and  $R'$  those at the points  $A, C$ , there obtains, *Case 4*,

$$R = \frac{5}{8} w l \cos. \alpha. \quad R' = \frac{3}{16} w l \cos. \alpha.$$

To find the tension  $T$  on the tie-rod  $A D'$ ; the difference between the normal component of the tension and that of the reaction  $w l$  of the weight of the roof at the point  $A$  is equal to the normal component  $R'$ , therefore

$$w l \cos. \alpha - T \sin. \alpha = \frac{3}{16} w l \cos. \alpha. \therefore T = \frac{5}{8} w l \cot. \alpha.$$

To find the tension  $S$  on  $C D'$ ; the difference of the component of this tension and of the component of  $H$  perpendicular to the rafter is also equal to  $R'$ , therefore,

$$\frac{1}{2} w l \cos. \alpha - S \sin. \alpha = \frac{3}{16} w l \cos. \alpha. \therefore S = \frac{1}{16} w l \cot. \alpha.$$

As the portion of the tie-beam between the points  $D' D$  belongs only to the primary truss  $A C B$ , the strain upon it will be due to

the horizontal reaction  $H$  of the two halves of the truss at  $C$ , and will therefore be equal to  $\frac{1}{2} w l \cot. a$ .

From these values of the forces of compression and extension on the different parts of the truss, the strains on the unit of area on each part can be found as in the preceding case.

*Case 7.* (Fig.  $B'$ .) As the rafter is here supported at three intermediate points of support, dividing it into four equal segments, each of which sustains  $\frac{1}{4} w l$  uniformly distributed, the normal pressure, and consequent reactions, at the points of support will be the same as found, *Case 3*, §  $t$ .

Representing by

$P$ , the normal pressure at the middle point of the rafter ;

$P'$ ,  $P''$ , those at the other two intermediate points ;

$P'''$ ,  $P''''$ , those at the ends ;

$T$ ,  $T'$ , the tensions on the segments  $B H$ ,  $D H$  of the horizontal tie-rod of the larger secondary truss ;

$S$ ,  $S'$ , those on the corresponding segments of the inclined tie-rod ;

$T''$ ,  $S''$ , those on the two tie-rods of the smaller secondary trusses ;

$H$ , the horizontal reaction of the halves of the primary truss, and which is equal to the tension on the segment  $D D'$  of the tie-rod which connects them ;

$w l$ , the vertical reaction at  $B$  ;

$a$ , the angle  $C B D''$  ;

$R$ , the pressure on the main strut  $D E$ .

Then there obtains for the tension  $H$  of the segment  $D D'$  of the tie-beam

$$H = \frac{1}{2} w l \cot. a$$

For the tension  $T$  of the segment  $B H$  of the tie-beam

$$w l \cos. a - T \sin. a = P'' \quad \therefore \quad T = \frac{w l \cos. a - P''}{\sin. a}$$

For the corresponding tension  $S$  on the segment  $C I$  of the inclined tie-rod,

$$H \sin. a - S \sin. a = P'' \quad \therefore \quad S = \frac{H \sin. a - P''}{\sin. a}$$

For the tensions  $T'$   $T''$ , as they with  $T$  and  $P'$  are in equilibrio at the point  $H$ , the algebraic sums of their components perpendicular and parallel to  $H G$ , will respectively be equal to zero ; therefore

$$T' \cos. a + T'' \cos. a - T \cos. a = 0 \quad \therefore \quad T' + T'' - T = 0$$

$$T' \sin. a - T'' \sin. a - T \sin. a + P' = 0,$$

$$\therefore (T' - T'' - T) \sin. a + P' = 0.$$

In like manner, for the tensions  $S'$ ,  $S''$ ,  $S$  and the pressure  $P'$ , there obtains

$$\begin{aligned} S' + S'' - S &= 0 \\ (S' - S'' - S) \sin. \alpha + P' &= 0 \end{aligned}$$

From these four last equations, the values of  $T'$ ,  $T''$ ,  $S'$ ,  $S''$  can be readily found, as  $S$  and  $P'$  are known. Those of  $T''$  and  $S''$ , are

$$T'' = S'' = \frac{1}{2} \frac{P}{\sin. \alpha}$$

The strain upon the main strut is due to the normal pressure  $P$  and the components of  $T''$  and  $S''$  in the direction of  $P$ ; there obtains therefore,

$$R = P + (T'' + S'') \sin. \alpha.$$

This value of  $R$  is balanced by the components of  $T'$ ,  $S'$  in the contrary direction.

Fig. C'

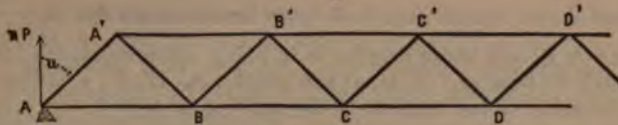

*Case 8. (Fig. C'.) Single lattice girder.*—This girder, which consists of an upper and lower beam  $A'D'$ ,  $AD$ , connected by diagonal braces  $A'A'$ ,  $A'B'$ ,  $B'B'$ , etc., which make equal angles with  $AD$ ,  $A'D'$ , may be regarded as an articulated system in which the points of articulation are  $A$ ,  $A'$ ,  $B$ ,  $B'$ , etc.; and the strains upon each piece may be found as in *Case 5*.

The girder may be strained either by a single force acting at any point of it perpendicular to  $A'D'$  or  $AD$ ; or by equal forces acting at the points of articulation  $B$ ,  $C$ ,  $D$ , etc., which would result from a uniform pressure along the lower beam.

Supposing the girder to rest on horizontal points of support at its extremities, let  $2W$  be a weight suspended at its middle point, and  $\alpha$  the angle between the braces and a vertical line; then each point of support will yield a reaction  $W$ , and will cause a strain in the direction of the axes of each of the two pieces  $AA'$ ,  $AB$  connected at  $A$ . To find the direction and amount of each of these forces, let a length equal to  $W$  be set off from  $A$  on the vertical through it, as the resultant pressure, and the parallelogram of forces be constructed on it, having its components in the direction  $AA'$

$B A$ ; that in the direction  $A A'$  will be  $\frac{W}{\cos. a}$ , the other  $W \tan. a$ ; showing that  $A A'$  is subjected to compression and  $B A$  to extension.

The force  $\frac{W}{\cos. a}$  is transmitted to the point  $A'$ , where it is received and counterbalanced by the resistances offered by the pieces  $A' B'$  and  $A' B$ . Prolonging  $A A'$ , beyond  $A$ , setting off from  $A'$  on this prolongation  $\frac{W}{\cos. a}$  as a resultant, and constructing the parallelogram of forces in the direction  $B A'$  and  $A' B'$ ; the component in the direction  $B A'$  will be  $\frac{W}{\cos. a}$ ; that in  $A' B'$ ,  $2 W \tan. a$ . The first will cause extension, the second compression.

The force  $\frac{W}{\cos. a}$  is transmitted to the point  $B$ , where, resolved in the directions  $B B'$ ,  $B C$ , the two components will be as before  $\frac{W}{\cos. a}$ , and  $2 W \tan. a$ ; and the same will obtain by a like process at the other points of articulation.

From this it is seen that each brace bears a strain due to  $\frac{W}{\cos. a}$ ; the one  $A A'$  and those parallel to it being compressed, the others subjected to tension. That, at the points,  $A', B', C'$ , etc., there is a compression of the segment to the right equal to  $2 W \tan. a$ , from the action of each brace separately, but as these pressures collectively accumulate from  $A'$ , by  $2 W \tan. a$  at  $B', C', D'$ , etc.; the pressures on the successive segments will be

$2 W \tan. a$  for  $A' B'$ ;  $4 W \tan. a$  for  $B' C'$ ;  $6 W \tan. a$  for  $C' D'$ , etc.

On the lower beam, in like manner, the tension on the segment  $A B$  is  $W \tan. a$ ; that on  $B C$ ,  $3 W \tan. a$ ; on  $C D$ ,  $5 W \tan. a$ , etc. The compressions and tensions thus increasing towards the middle of the upper and lower beams.

It may be remarked that the directions of the compression are from  $A'$  towards  $A$ , etc., for the compressed braces; and those of the tensions from  $A'$  towards  $B$ , etc.

Were the force  $2 W$  to act at any other point, it would be simply necessary to find, from the theorem of parallel forces, the components at the points of support, and find from these, regarded as the reactions of these points, the strains as just explained.

In the case where the weight is uniformly distributed, let  $2 w$  be the vertical weight at each lower point  $B, C$ , etc., and  $n$  the number of these lower points. The entire distributed weight will be  $2 n w$ , from which there will be a reaction  $n w$  at each support.

It is to be noted, in the first place, that following out the same methods for the reaction  $n w$  as in the preceding example for that **W**, the same law of compressions and tensions would obtain; but as at each point **B, C, D**, etc., there is a direct vertical force  $2 w$ , acting in opposition to the transmitted force through the braces, the components of  $2 w$  in the direction of the braces and lower beam must be subtracted from those of the transmitted forces along these pieces.

Thus for the point **A**, the components of  $n w$  are  $\frac{n w}{\cos. \alpha}$ , and  $n w \tan. \alpha$ ; at the point **A'** they are  $\frac{n w}{\cos. \alpha}$  and  $2 n w \tan. \alpha$ ; at the point **B** they are  $\frac{n w}{\cos. \alpha} - \frac{2 w}{\cos. \alpha} = \frac{(n-2) w}{\cos. \alpha}$  and  $2 n w \tan. \alpha - 2 n w \tan. \alpha = (2n-2) w \tan. \alpha$ ; at the point **B'** they are  $\frac{(n-2) w}{\cos. \alpha}$  and  $2(2n-2) w \tan. \alpha$ , etc.

To obtain the compression or extension on any brace it will only be necessary to subtract  $\frac{2 w}{\cos. \alpha}$  from that on the one preceding.

To obtain the compression on any segment of the upper beam, there must be added to the compression transmitted to it by the brace with which it is connected, the respective compressions on each of the segments preceding it. The same law obtains for the segments of the lower beam.

Thus for the compressed braces **AA', BB', CC'**, etc., the forces of compression are respectively,

$$\frac{n w}{\cos. \alpha}, \frac{(n-2) w}{\cos. \alpha}, \frac{(n-4) w}{\cos. \alpha}, \frac{(n-6) w}{\cos. \alpha}, \text{ etc.}$$

For the upper segments **A'B', B'C', C'D'**, etc., the forces of compression are respectively,  $2 n w \tan. \alpha$ ,  $4(n-1) w \tan. \alpha$ ,  $6(n-2) w \tan. \alpha$ ,  $8(n-3) w \tan. \alpha$ , etc.

For the lower segments **AB, BC, CD**, etc., the forces of tension are respectively,  $n w \tan. \alpha$ ,  $[n+2(n-1)] w \tan. \alpha$ ,  $[n+4(n-2)] w \tan. \alpha$ ,  $[n+6(n-3)] w \tan. \alpha$ , etc.

From the preceding expressions it will be seen that the strains on the struts decrease from the points of support towards the middle of the truss; and the compressions on the upper segments and the tensions on the lower increase from these points to the middle.

It may be noted that in this case, as in *Case 5*, the successive resolutions of the external forces might have been made by commencing at the middle secondary truss, composed of the two middle braces and the segment of either the lower or upper beam connect-

ing their two divergent sides at the base, and in this way the same results have been arrived at by the successive accumulations of pressure at the points of articulation, from the successive additions of the secondary triangular trusses which compose the entire truss. In *Case 5* also, as in this case, the resolutions of the external forces might have commenced with the primary truss, descending from this to each secondary truss in its order. The mode of building up the main truss, piece by piece, and showing the effect of these successive additions upon the strains, is more palpable to many than the contrary process.

The foregoing expressions can each be deduced from a general term as follows: let  $i$  represent the numbers 1, 2, 3, etc., or the order of each term; then

$$2 i (n - i + 1) w \tan. \alpha$$

will be the general term from which the compression on each segment of the upper horizontal beam can be deduced; and

$$\left\{ n + 2 (i - 1) (n - i + 1) \right\} w \tan. \alpha$$

that from which the tensions on the segments of the bottom beam can be found.

The maximum of the first expression is given by the relation  $i = \frac{n+1}{2}$ ; and that of the second by  $i = \frac{n+2}{2}$ . These values cannot obtain rigorously at the same time, since  $i$  can only be an entire number; but one of them may be rigorously true and the other very nearly so when the value of  $n$  is considerable. The two maximum values will be

$$\frac{1}{2} p \tan. \alpha (n + 1)^2 \text{ and } \frac{1}{2} p \tan. \alpha \left\{ (n + 1)^2 - 1 \right\}.$$

In other words, if  $N$  represents the number of times that the segment  $AB$  is contained in the horizontal distance between the end supports; then the greatest horizontal compression or tension will be sensibly expressed by  $\frac{1}{2} w N^2 \tan. \alpha$ .

To pass now from the abstract case above to the ordinary lattice truss, like those used in our country, the following approximate methods may be employed. In the first place, the segments of the horizontal chords which are supposed to be a system articulated at their extremities may be replaced by two entire beams, the mean fibres of which will be  $ABCD \dots$  and  $A'B'C'D' \dots$ ; for as the transversal dimensions of each of them is very small compared to their length, they will be very flexible, which will permit of their being assimilated to a system articulated as above mentioned. **It**

the second place, the single brace  $A A'$  may be subdivided into several others inclined like it in the same direction and at equal distances apart so as to occupy the space between  $A A'$  and  $B B'$ ; the same transformation may be supposed made with respect to the other set of braces. It will readily be inferred that if  $A B$  is but a small portion of the entire distances between the supports, the second transformation will have but a slight effect on the compressions and tensions of the horizontal beams; and as regards the braces, compressed between any two consecutive parallel ones of the first system, they will as a whole produce about the same effects as the two they replace; and the sum of the areas of their cross-sections should therefore be the same as that of the two they replace.

It should be well understood that in this change the braces of the new system are supposed to be connected only at their ends. But in fact they are usually connected where they cross each other, which is in favor of the safety of the system, but as it is not easy to render a satisfactory account of the effect of this connection it may be left out of consideration.

The *method* given in the preceding analysis is applicable to the cases where the load is applied to the upper chord, and also where it is applied to only a part of the joints (or nodes) of the lower or upper chord. It may easily be shown that some of the members of the webbing will be strained most when a part of the uniform load is removed, but the strains upon the horizontal members (chords) will be greatest when the frame is fully loaded. In the figure

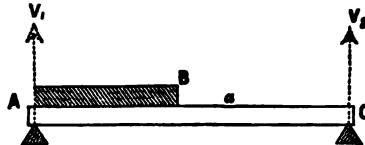

Let  $L = AC$ ;

$w$  = the weight per foot of length of the beam (or of the dead load);

$w'$  = the weight per foot of length of the moving or live load;

$x = AB$  = the length of the live load;

$V_1$  = the upward action of the support at A;

$V_2$  = the upward action of the support at C;

$z = Cs$  = the distance from C; and

$S_s$  = the shearing stress, or the resultant vertical force at any required point.

We have

$$V_1 = \frac{1}{2} w L + \frac{w'}{L} (L - \frac{1}{2} x) x$$

$$V_2 = \frac{1}{2} w L + \frac{w' x^2}{2L}$$

$$S_s = V_2 - w z = \frac{1}{2} w L + \frac{w' x^2}{2L} - w z$$



If now we suppose that the load extends from **A** to **a**, the support at **C** will sustain

$$V_s = \frac{w' \times B a (x + \frac{1}{2} B a)}{L} + \frac{1}{2} w L + \frac{w' x^2}{2L}$$

and the vertical force at **a** will be

$$\frac{w' \times B a (x + \frac{1}{2} B a)}{L} + \frac{1}{2} w L + \frac{w' x^2}{2L} - w x$$

which evidently exceeds the former value of  $S_s$  and hence the vertical shearing stress at any point is greatest where the load extends from that point to the support. It now remains to be shown that the greatest when it extends over the longer segment.

If the live load extends from **A** to **a**, then  $x = L - x$  and the shearing stress will be

$$S_s = \frac{1}{2} w L + \frac{w' x^2}{2L} - w (L - x)$$

If the live load extends from **a** to **C**, the shearing stress will be,

$$S's = \frac{1}{2} w L + \frac{w'}{2L} (L - x)^2$$

$$\therefore S_s - S's = -\frac{1}{2} (w' + 2w) (L - 2x) - wx$$

which is zero for  $x = \frac{1}{2} L$ ;  
negative for  $x < \frac{1}{2} L$ ; and  
positive for  $x > \frac{1}{2} L$ ;

hence, the vertical shearing stress at any point for an uniform load is greatest when the longer segment is loaded and the shorter is unloaded.

Reducing the preceding value of  $S_s$  gives

$$S_s = \frac{w' x^2}{2L} + wx - \frac{1}{2} w L,$$

which, considered as the equation of a curve, is represented in the annexed figure. The ordinates are  $s$  and the abscissa is  $x$ .

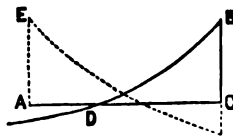

If a live load were placed upon the beam and extend over the whole length, and the beam be considered as a rigid body, and the live load move off with a shock in the direction from **C** towards **A**, then will the ordinates of the curve **DB** at any point represent the vertical shearing stress when the rear end of the load reaches that point.

point. The curve through E represents the case for a load moving off in the opposite direction.

In truss-bridges, having parallel chords, the vertical shearing is sustained by the inclined ties or braces, and hence they should incline one way (either from or towards) from C to D, and in the opposite direction from A to where the other curve cuts the line AC. For a certain distance, each side of the centre, they incline both ways. In the case of lattice-bridges, or Warren girders, the inclined pieces which constitute the tie-braces near the middle of the truss may be subjected to both tension and compression under the action of a moving load.

The law of strains upon the chords may also be illustrated by assuming that the strains are continuous functions of the abscissa.

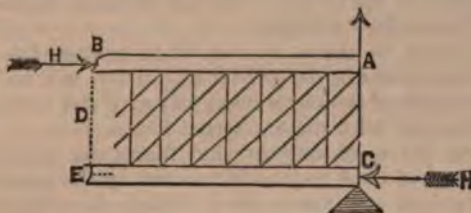

Let  $w$  = the load per foot of length;  
 $W$  = the total load on the bridge;  
 $H$  = the strain on the chords at any point;  
 $D$  = the depth of the truss; and  
 $x$  = AB.

Taking the origin of moments at E, and we have

$$\frac{1}{2} W x - \frac{1}{2} w x^2 = H.D \therefore H = \frac{W x - w x^2}{2D},$$

which is the equation of a parabola.

In the case of truss-bridges the strains upon the chords do not constantly vary, but are uniform from one joint (or point of attachment of the ties) to the next, but the *general law* of change is the same for all trusses having parallel chords as that above illustrated. For analyses of panel systems see Wood's *Treatise on Bridges and Roofs*.

v. *Curved Beams*. By a curved beam will be understood a beam which is made to assume any curvilinear form in the direction of its length, most generally, in cases of practice, either that of a circular or a parabolic arc, and which is used to resist and transmit to fixed points of support the strains caused by the exterior forces to which it may be subjected.

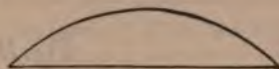

In conformity to what most generally obtains in practice, and for the greater simplification of the analytical results, such a beam will be supposed, 1st, to be of uniform cross-section; 2d, to be generated by the cross-section being moved along the mean fibre of the beam, which is assumed to be a plane curve, so that it shall always be in a plane perpendicular to that of the mean fibre and normal to it, and have its centre of gravity on the mean fibre; 3d, that the dimensions of the cross-section, in the direction of the radius of curvature of the mean fibre, shall be but a very small fraction of this radius. These conditions being satisfied, any very small fractional portion of the beam, comprised between two consecutive positions of the generating cross-section, may be regarded as a right prism, composed of elementary fibres, each of which has an element of the cross-section for its base, and the distance between the two consecutive planes for its length.

A curved beam, as above defined, when subjected to the action of external forces, which, for greater simplicity, will be assumed as acting in the plane of the mean fibre, may give rise to three distinct problems connected with these external forces.

In the first place, all the external forces are not in all cases given; as a part of them may be occasioned by the reactions caused by the fixed points, or other means by which the extremities of the beam are kept in position, and this reaction, being an unknown force, has to be found, as a preliminary step to the solution of two other problems: The one to find the tensions or pressures on the fibres caused by the external forces; the other to find the change of form in the beam caused by the same forces.

Prob. 1. *To find the forces of reaction caused by the external forces at the points of support of the curved beam.*

With the conditions already laid down, to further simplify the problem, and bring it within what usually obtains in practice; let us suppose the curved beam to be symmetrical with respect to a vertical line drawn through the top point of the mean fibre; that it rests at its lowest points on two supports which are on the same horizontal line; and that it is acted upon either by a single vertical

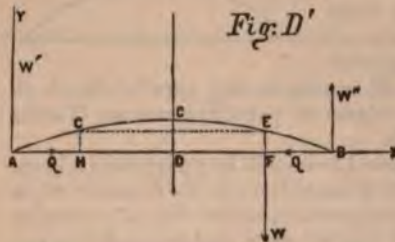

force, at some point between the top and bottom; or that it is subjected to a strain arising from a weight uniformly distributed along a horizontal line, and transmitted to the beam, or by one which is uniformly distributed directly along the beam.

*Case 1.* Let ACB, Fig. D', be the curve of the mean fibre, regarded as symmetrical with respect to the vertical CD, resting on the points of support A, B,

on the same horizontal line A B; and let W be the vertical force acting on it at the point E.

Represent by W' and W'' the two vertical components of the forces of reaction at the points A and B; by Q' and Q the horizontal components of the same forces; by 2 a the chord A B of the arc; by d the arm of lever of W with respect to the point A, regarded as the centre of moments.

From the conditions of statical equilibrium, there obtains

$$\begin{aligned} Q' - Q &= 0. \\ W' + W'' + W &= 0. \\ W'' 2 a - W. d &= 0. \end{aligned}$$

Here we have but three equations and four unknown quantities. A fourth equation may be obtained, and the problem thus made determinate, by introducing the condition that the points of support shall remain fixed.

To express this last condition, let us, in the first place, consider the force W to be replaced by its two components, one perpendicular to the cross-section at any point, as E for example, and which will produce an elongation or a shortening of the fibres, either by extension or by compression; the other by a couple, the moment of which may be expressed by M, and which will produce like effects on the same by bending the beam. The effect of these forces on the beam, were it free to move at the two ends, would be to change the length of the chord A B of the arc.

Now, assuming the lines A X and A Y as the axes of co-ordinates; and resuming equations (A) and (I'); the first of which (A)

$$i = \frac{W L}{E A},$$

expresses the elongation due to a force acting parallel to the mean fibre; and the second (I')

$$* \alpha = \frac{W z. L}{E I}$$

gives the angle between two consecutive normals after the deflec-

\* Supposing the point B to move through the small angle  $\alpha$ , around E as fixed, it will describe an arc B M, with the radius E B, which will be expressed by  $E B \times \alpha$ . Now the horizontal and vertical components of this motion, considering the small arc B M as a right line, are B O and M O. But as the triangles E F B and B O M are right angled and similar there obtains

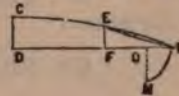

$$E B : F E :: B M : B O = \frac{B M \times F E}{F B} = y \alpha,$$

by substituting  $E B \times \alpha$  for B M, and  $y$ , the ordinate of the point E, for F B

tion caused by the bending forces; representing by  $dx$  the length of the elementary prism along the mean fibre, we obtain from (A), substituting  $P$  for the normal component of all the forces for  $L$ ,  $dx$ , the projection of the elementary prism on the axis

$$\frac{P dx}{EA}, (a')$$

as the amount by which the portion of the chord  $dx$  is elongated or compressed. Again, from Eq. (I'), substituting  $M$  for  $W$  bending moment, with respect to the neutral axis at  $E$ , of a deflecting forces, forming a couple, acting at  $B$ , and  $ds$ , the length of the elementary prism, for  $L$ ; and noting that were the point free to move around the neutral axis at  $E$ , that the horizontal component of its motion towards  $A$  would be found by multiplying angle  $\alpha$  by the ordinate  $y$  of the point  $E$ , or  $y \alpha$ , there obtain express this change of length of  $ds$  in the direction  $BA$ ,

$$\frac{M ds y}{EI}, (b')$$

Now by the addition of the expressions (a') and (b'), there obtain

$$\frac{M ds y}{EI} + \frac{P dx}{EA}, (c')$$

to express the total elongation or compression of the portion of the chord corresponding to  $ds$ . Integrating (c') between the limits  $0$  and  $2\alpha$  we obtain

$$\int_0^{2\alpha} \left( \frac{M y}{EI} \frac{ds}{dx} + \frac{P}{EA} \right) dx = 0, (1)$$

to express the fourth equation, containing the condition that the length of the chord shall remain unchanged.

Now in Eq. (1),  $M$  is the moment of all the deflecting forces

In like manner

$$EB : FB :: BM : MO = \frac{BM \times FB}{EB} = (a-x) \alpha,$$

by substituting as above for  $BM$ , and  $(a-x)$ , the abscissa of the point for  $FB$ .

The quantities  $BO$  and  $MO$  are evidently the amount by which the deflection  $FB$  of the half span and that  $FE$  of the rise would be changed if the point  $B$  free to take the motion assumed, the point  $E$  remaining fixed.

known and unknown, with respect to the point E, acting at B. Representing by  $M'$  the moment of those that are known, and by  $Q y$  that of the unknown, there obtains

$$M = M' - Q y. (d')$$

In like manner, the components of P and Q, on the projection of the tangent at the point E, may be represented by  $P'$  for that of the known forces; and by  $Q \frac{dx}{ds}$  for the unknown. There obtains therefore

$$P = P' - Q \frac{dx}{ds}. (e')$$

In other words,  $M'$  is the sum of the moments, with respect to any point E of the mean fibre, the ordinate of which is  $y$ , of all the forces which act from this point to the point B, the moment of Q not being considered; and, in like manner,  $P'$  is the sum of the projections of the same forces on the tangent at E, Q being also here left out.  $M'$  and  $P'$  are thus immediately functions of  $x$  and easily found; the only unknown quantities in M and P being the unknown terms  $W''$  and Q; the first of which is given by the third of the equations of the statical equilibrium of the forces. Substituting the values of M and P, expressions (d'), (e'), in Eq. (1), and making  $E I = \epsilon$ , and  $E A = e$ , there obtains:

$$\int_0^{2a} \frac{M' y}{s} \frac{ds}{dx} dx - Q \int_0^{2a} \frac{y^2 ds}{s dx} dx + \int_0^{2a} \frac{P'}{e} dx - Q \int_0^{2a} \frac{1}{e} \frac{dx}{ds} dx = 0; (2)$$

hence

$$Q = \frac{\int_0^{2a} \frac{M' y}{s} \frac{ds}{dx} dx + \int_0^{2a} \frac{P'}{e} ds}{\int_0^{2a} \frac{y^2 ds}{s dx} dx + \int_0^{2a} \frac{1}{e} \frac{dx}{ds} ds}. (3)$$

Having thus determined the values of  $W''$  and  $Q$ , those of  $W$  and  $Q'$  can be found from the three equations of statical equilibrium above.

$Q$  and  $Q'$ , which are equal in the case under consideration, are the horizontal pressures on the points of support, and are to be called the *horizontal thrust*.

*Case 2. The arc being symmetrical and loaded symmetrically.* The conditions in this case are the same as in the preceding case, that, instead of a single weight  $W$  acting at  $E$ , there is another acting at the point  $G$ , symmetrically situated with  $E$ , with respect to the vertical  $CD$  bisecting the chord.

Taking  $DY$  and  $DX$  as the axes of co-ordinates, Eq. (4) comes for this case,

$$\int_0^a \left( \frac{M y ds}{s dx} + \frac{P}{e} \right) dx = 0. \quad (4)$$

Substituting in Eq. (4)  $M' - Q y$  for  $M$ , and  $P' - Q \frac{dx}{ds}$  for  $P$ , there obtains

$$\int_0^a \frac{M' y ds}{s dx} dx - Q \int_0^a \frac{y' ds}{s dx} dx + \int_0^a \frac{P'}{e} dx - Q \int_0^a \frac{1}{e} \frac{dx}{ds} dx = 0. \quad (5)$$

hence

$$Q = \frac{\int_0^a \frac{M' y}{s} \frac{ds}{dx} dx + \int_0^a \frac{P'}{e} dx}{\int_0^a \frac{y'}{s} \frac{ds}{dx} dx + \int_0^a \frac{1}{e} \frac{dx}{ds} dx} \quad (6)$$

*Application of the preceding Eqs. to the case of a curved*

*the mean fibre of which is a circular arc, and which is acted on by a weight  $W$  applied at the point  $E$ .*

*Case 1.* Let  $A C B$  (Fig.  $E'$ ) be the arc of mean fibre, supported at the points  $A, B$ , and acted on at the point  $E$  by the weight  $W$ .

Taking  $O$  for the centre of the curve, let  $D Y, D X$  be the co-ordinate axes. Represent by

$2 a = A B$  the chord of the arc ;

$f = D C$  the versed sine, or rise ;

$\rho = O B$  the radius of the arc ;

$\alpha$  the angle which a radius  $O I$ , at any point  $I$ , makes with the axis  $O Y$  ;

$\phi$  the angle which  $O B$  makes with  $O Y$  ;

$\theta$  the particular value of  $\alpha$  which corresponds to the point  $E$  ;

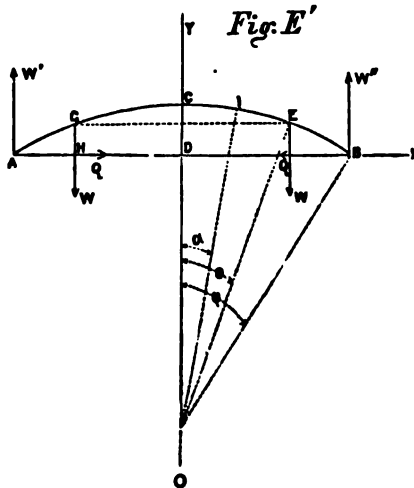

$W'', Q, W', Q'$  the vertical and horizontal components of the forces of reaction at the points  $B, A$ .

Using the same notation as in the preceding equations ; there obtains to express the statical conditions of equilibrium

$$\begin{aligned} Q - Q' &= 0 \\ W' + W'' - W &= 0 \\ W \rho (\sin \phi + \sin \theta) &= 2 W'' \rho \sin \phi. \end{aligned}$$

Eliminating  $W''$  between the second and third Eqs. there obtains :

$$W'' = \frac{1}{2} W \left( 1 + \frac{\sin \theta}{\sin \phi} \right),$$



$$W' = \frac{1}{2} W \left(1 - \frac{\sin \theta}{\sin \phi}\right),$$

$$Q = Q'.$$

$W'$  and  $W''$  being known from the first two Eqs. there remains only  $Q$  and  $Q'$  to be found. To find these, it will only be necessary to substitute the known terms in these Eqs. in Eq. (3) to find  $Q$ . But we have a more simple and neat method of arriving at the same result by supposing an equal weight  $W$  to act at the point  $G$ , symmetrical with respect to  $E$ , and the co-ordinate axis  $QY$ , and then to use Eq. (6) to find the value of  $Q$ . Supposing the second equal weight  $W$  to be applied at  $G$ , and that the horizontal component of the new reaction to be represented by  $Q_1$ , then, by a very simple process of reasoning, it can be shown, that the relation expressed by

$$2 Q = Q_1$$

will obtain.

Introducing this value of  $2 Q$  in Eq. (6), there obtains

$$Q_1 = \frac{\int_0^a \frac{M' y}{\epsilon} \frac{ds}{dx} dx + \int_0^a \frac{P'}{\epsilon} ds}{\int_0^a \frac{y}{\epsilon} \frac{ds}{dx} dx + \int_0^a \frac{1}{\epsilon} \frac{dx}{ds} dx}. \quad (7)$$

In finding the values of  $M'$  and  $P'$ , it must be observed, that, after the application of the second weight  $W$ , the vertical components of the reactions at  $A$  and  $B$  are respectively  $W$ .

Now, in calculating the values of  $M'$  and  $P'$  in functions of the angle  $\alpha$ , the following relations obtain,

$$\text{From } \alpha = 0 \text{ to } \alpha = \theta, \quad \begin{cases} M' = W \rho (\sin \phi - \sin \theta), \\ P' = 0, \end{cases}$$

$$\text{From } \alpha = \theta \text{ to } \alpha = \phi \quad \begin{cases} M' = W \rho (\sin \phi - \sin \alpha), \\ P' = -W \sin \alpha; \end{cases}$$

also  $y = \rho (\cos \alpha - \cos \phi)$ ,  $x = \rho \sin \alpha$ ,  $ds = \rho d\alpha$ ,  $dx = \rho \cos \alpha d\alpha$ ; substituting these values of  $M'$ ,  $P'$ , etc., in Eq. (7), and observing that  $\rho = \frac{a}{\sin \phi}$ , and  $\epsilon$  and  $\epsilon$  are constants, there obtains for the numerator of the fraction,

$$\int_0^a \left( \frac{M' y ds}{\epsilon dx} + \frac{P'}{\epsilon} \right) dx = \frac{W \rho^3}{\epsilon} (\sin \phi - \sin \theta) \int_0^\theta (\cos \alpha - \cos \phi) d\alpha + \frac{W \rho^3}{\epsilon} \int_\theta^\phi \left\{ \sin(\phi - \sin \alpha) (\cos \alpha - \cos \phi) - \frac{r^2}{a^2} \sin^2 \phi \sin \alpha \cos \alpha \right\} d\alpha;$$

and for the denominator,

$$\int_0^a \left( \frac{y^2 ds}{\epsilon dx} + \frac{1 dx}{\epsilon ds} \right) dx = \frac{\rho^3}{\epsilon} \int_0^\phi \left\{ (\cos \alpha - \cos \phi)^2 + \frac{r^2}{a^2} \sin^2 \phi \cos^2 \alpha \right\} d\alpha$$

Performing the algebraic operations indicated by the symbols, and integrating the resulting monomials, by well known rules, ( $\alpha$ ) and then doubling the denominator of  $Q$ , the value of  $Q$  will be found. This value can be placed under the following form :

$$Q = W \frac{A - \frac{r^2}{a^2} \sin^2 \phi (\sin^2 \phi - \sin^2 \theta)}{B + \frac{r^2}{a^2} \sin^2 \phi (\phi + \sin \phi \cos \phi)}, \quad (8),$$

by making

$$A = \frac{1}{2} (\sin^2 \phi - \sin^2 \theta) + \cos \phi (\cos \theta + \theta \sin \theta - \cos \phi - \phi \sin \phi),$$

$$B = \phi + 2 \phi \cos^2 \phi - 3 \sin \phi \cos \phi.$$

*Case 2. Horizontal thrust caused by the weight of the curved piece itself, or by a weight uniformly distributed over a portion of its length.*

---

(a) For the integrals  $\int \sin \alpha \cos \alpha d\alpha$  and  $\int \cos^2 \alpha d\alpha$  see *Threat's Calculus*, Arts. 190, 191, pp. 265, 266.

Represent by  $w$  the weight uniformly distributed over unity of length of the mean fibre; by  $\theta_1$  and  $\theta_2$ , the limits of the angles between which a weight expressed by  $w \rho (\theta_2 - \theta_1)$  acts; and by  $w \rho d \theta$  the weight on the element of the arc comprised between  $\theta$  and  $\theta + d \theta$ .

Now, the infinitely small horizontal thrust  $d Q$ , caused by the weight  $w \rho d \theta$  distributed over the arc  $\rho d \theta$ , will, from Eq. (8), be expressed by

$$d Q = \frac{A - \frac{1}{2} \frac{r^2}{a^2} \sin^2 \phi (\sin^2 \phi - \sin^2 \theta)}{B + \frac{r^2}{a^2} \sin^2 \phi (\phi + \sin \phi \cos \phi)} w \rho d \theta. \quad (9)$$

Clearing the denominator, Eq. (9), dividing by  $w \rho$ , and integrating, there obtains

$$\frac{Q}{w \rho} \left\{ B + \frac{r^2}{a^2} \sin^2 \phi (\phi + \sin \phi \cos \phi) \right\} = \int_{\theta_1}^{\theta_2} A d \theta - \frac{1}{2} \frac{r^2}{a^2} \sin^2 \phi \left\{ (\theta_2 - \theta_1) \sin^2 \phi - \int_{\theta_1}^{\theta_2} \sin^2 \theta d \theta \right\} \quad (10)$$

Restoring the preceding value of  $A$ , performing the algebraic operations indicated by the symbols, and integrating the several differential monomials, there obtains,

$$\begin{aligned} \frac{Q}{w \rho} \left\{ B + \frac{r^2}{a^2} \sin^2 \phi (\phi + \sin \phi \cos \phi) \right\} &= \left( \frac{1}{2} \sin^2 \phi - \cos^2 \phi - \phi \right. \\ &\quad \left. \sin \phi \cos \phi - \frac{1}{4} \right) \\ &\quad \times (\theta_2 - \theta_1) + \frac{1}{4} (\sin \theta_2 \cos \theta_2 - \sin \theta_1 \cos \theta_1) \\ &\quad + 2 \cos \phi (\sin \theta_2 - \sin \theta_1) - \cos \phi (\theta_2 \cos \theta_2 - \theta_1 \cos \theta_1) \\ &\quad - \frac{1}{2} \frac{r^2}{a^2} \sin^2 \phi \left\{ (\theta_2 - \theta_1) (\sin^2 \phi - \frac{1}{2}) + \frac{1}{2} \sin \theta_2 \cos \theta_2 - \frac{1}{2} \sin \theta_1 \right. \\ &\quad \left. \cos \theta_1 \right\}. \quad (10) \end{aligned}$$

---

(b) For the integral  $\int \theta \sin \theta d \theta$  see *Church's Calculus*, Art. 169, p. 234.

By making  $C = \frac{1}{2} - \frac{1}{2} \cos^2 \phi - \phi \sin \phi \cos \phi + \frac{1}{2} \frac{\sin \phi}{\phi} \cos \phi$ ,  
and  $D = \frac{1}{2} (\sin^2 \phi - \frac{1}{2} + \frac{1}{2} \frac{\sin \phi}{\phi} \cos \phi)$ , placing them in the preceding  
Eq., and then obtaining the value of  $Q$ , we have

$$Q = 2 w \rho \phi \frac{C - D \frac{r^2}{a^2} \sin^2 \phi}{B + \frac{r^2}{a^2} \sin^2 \phi (\phi + \sin \phi \cos \phi)} \quad (11)$$

for the horizontal thrust due to the weight of the curved piece; and which would be sensibly the same in form were a weight uniformly distributed over the top surface of the piece to be added to its own weight.

To apply this formula when the weight of the entire curved piece is alone considered, we should have to substitute, in Eq. (10), for  $w$  the weight of a right prism having the same cross-section as the piece, and one foot, if the foot is the unit of measure, in height, and make  $\theta_1 = \phi$ ,  $\theta_2 = -\theta$ , at the same time.

*Case 3. A weight being uniformly distributed along the chord of the arc, or over a horizontal line through its crown, and transmitted to the piece, to determine the horizontal thrust.*

In this case, as the  $w$  corresponds to the unit in length measured along the horizontal, the elementary arc of the mean fibre, which has for its length  $\rho d\theta$ , will have for its projection on the horizontal,  $\rho \cos \theta d\theta$ , and it will sustain a weight expressed by  $w \rho \cos \theta d\theta$ . Substituting this value in Eq. (9) there obtains

$$dQ = w \rho \cos \theta d\theta \frac{A - \frac{1}{2} \frac{r^2}{a^2} \sin^2 \phi (\sin^2 \phi - \sin^2 \theta)}{B + \frac{r^2}{a^2} \sin^2 \phi (\phi + \sin \phi \cos \phi)} \quad (12). \quad (c)$$

To obtain the value of  $Q$  between any two limits,  $\theta_1$  and  $\theta_2$ , Eq. (12) must be integrated between these limits. Performing the algebraical operations indicated by the symbols, and integrating each of the differential monomials, there obtains,

---

(c) For the integral  $\int \theta \sin \theta \cos \theta d\theta$ , which occurs in Eq (12), see *Thural's Calculus*, Art. 169, p. 234, and Art. 190, p. 265.

$$\frac{Q}{w \rho} \left\{ B + \frac{r^2}{a^2} \sin^2 \phi (\phi + \sin \phi \cos \phi) \right\} = \left( \frac{1}{2} \sin^2 \phi - \cos^2 \phi - \phi \cos \phi \right) (\sin \theta_2 - \sin \theta_1) - \frac{1}{2} (\sin^2 \theta_2 - \sin^2 \theta_1) + \frac{1}{2} \cos \phi (\theta_2 - \theta_1) + \frac{1}{2} \cos \phi (\theta_2 \sin^2 \theta_2 - \theta_1 \sin^2 \theta_1) + \frac{3}{4} \cos \phi (\sin \theta_2 \cos \theta_2 - \sin \theta_1 \cos \theta_1) - \frac{1}{2} \frac{r^2}{a^2} \sin^2 \phi \left\{ (\sin \theta_2 - \sin \theta_1) \sin^2 \phi - \frac{1}{2} (\sin^2 \theta_2 - \sin^2 \theta_1) \right\}.$$

By making  $\theta_1 = -\phi$ ,  $\theta_2 = \phi$ , and substituting  $\frac{a}{\sin \phi}$  for  $\rho$ , making  $C' = -\frac{1}{2} + \frac{r^2}{12} \sin^2 \phi + \frac{1}{4} \frac{\phi}{\sin \phi} \cos \phi - \frac{1}{2} \phi \sin \phi \cos \phi$  there obtains

$$C' = \frac{1}{2} \frac{r^2}{a^2} \sin^2 \phi$$

$$Q = 2 w a \frac{B + \frac{r^2}{a^2} \sin^2 \phi (\phi + \sin \phi \cos \phi)}{\sin \phi} \quad (13)$$

$$B + \frac{r^2}{a^2} \sin^2 \phi (\phi + \sin \phi \cos \phi)$$

for the value of the horizontal thrust in this case.

By introducing the value of the versed sine, or rise  $C D$ , ( $E'$ ) represented by  $f$ , into the preceding expressions, and by suitable developments and changes, for the purpose of simplifying results, the details of which cannot be entered into here, it can be shown, that, when the rise is small in comparison with the span  $\frac{f}{a}$  is a small fraction, the resulting values of  $Q$  will be approximately as follows:

When the load is uniformly distributed over the mean fibre,

$$Q = w \rho \phi \frac{a}{2f} \left( \frac{1 - \frac{3}{7} \frac{f^2}{a^2}}{1 + \frac{15}{8} \frac{r^2}{f^2}} \right); \quad (t)$$

and when distributed uniformly over the chord, or span,

$$Q = \frac{w a^2}{2 f} \left( \frac{1 - \frac{1}{7} \frac{f^2}{a^2}}{1 + \frac{15}{8} \frac{r^2}{f^2}} \right). \quad (t')$$

Now, as the value of  $Q$  in the case of a suspension system, being  $2 a$  for the span and  $f$  for the rise, in which the weight  $w$ , each unit of length, is uniformly distributed over the span, is

pressed by  $Q = \frac{w a^3}{2 f}$ , it follows, from the preceding value of  $Q$ , that it is less in a rigid than in a flexible system, under the same circumstances.

Prob. 2. *To find the maximum longitudinal strain on the unit of area in any given cross-section.*

The next problem, connected with this subject, is to find the amount of tension or compression on the unit of area of any cross-section of the piece, having given the extraneous forces to which it is subjected.

In the solution of this problem, the hypotheses will be adopted: 1st, that the distances of the extreme fibres from the horizontal line drawn through the centre of gravity of the cross-section are equal; 2d, that the weight, comprising that of the piece itself, is uniformly distributed with respect to a horizontal line drawn through the points of support; 3d, that the material is homogeneous throughout.

Preserving the same notations as in the preceding cases, call  $y$  the distance of any fibre from the horizontal through the centre of gravity of the section considered;  $+\frac{1}{2}h$  and  $-\frac{1}{2}h$  the distances of the extreme fibres from the same point.

As shown in what precedes, all the extraneous force, by which any cross-section is strained, can be reduced to one  $P$  acting in the plane of the mean fibre and perpendicular to the cross-section; and to a couple the moment of which is represented generally by  $M$ . Now from Eqs. (A) and (K) § I we have to express the strain on the unit of area, arising from the force  $P$ ,  $\frac{P}{A}$ , or  $\frac{P E}{e}$ , substituting  $e$  for  $E A$ ; and for the strain on the unit of area, at the distance  $y$  from the neutral axis, substituting in Eq. (K)  $M$  for  $W z$ , and  $e$  for  $I$ , there obtains, to express this strain,

$$\frac{M E y}{e}$$

Regarding the normal component  $P$  as positive, its value as before determined will be expressed by the equation,

$$P = -Q \cos \alpha - w \rho \sin^3 \alpha;$$

and the moment  $M$  by the equation

$$M = \frac{1}{2} w \rho^2 (\sin^2 \phi - \sin^2 \alpha) - Q \rho (\cos \alpha - \cos \phi).$$

The value of  $P$ , as here given, being essentially negative, the strain on the unit of surface, expressed by  $\frac{P E}{e}$ , will be one of com

pression. As to the expression  $\frac{M E y}{\epsilon}$ , which may be either positive or negative, it may give strains either of tension or compression, as points on one or the other side of the neutral axis are taken: the points strained may be either on the concave or convex face of the curved piece, as  $M$  is taken positive or negative.

As the strains due to  $P$  and the couple  $M$  are superposed, there will be a strain on the unit of area at the distance  $y$ , the absolute value of which will be expressed by

$$-\frac{P E}{\epsilon} \pm \frac{M E y}{\epsilon};$$

and when  $M$  produces a pressure, the sign of the second term of the preceding expression should be so taken as to add the two terms together. But, for the points, where  $M$ , acting alone, would produce a tension, their difference should be taken.

Now of the different values of this algebraic sum of the superposed forces, which vary with the angle  $\alpha$ , or the assumed position of the cross-section, that one is the important one which gives the greatest cross-strain on the unit of area at that point in which this strain is greatest in each cross-section, or the value of  $y$  corresponding to  $+\frac{h}{2}$  and  $-\frac{h}{2}$ .

Before proceeding to find this greatest value of the strain in question, it will be necessary to ascertain which of the two signs of  $\frac{M E y}{\epsilon}$  should be taken, as respects the position of the cross-section considered. For this purpose, taking the value of  $M$ , which is

$$M = -Q \rho (\cos \alpha - \cos \phi) + W' \rho (\sin \phi - \sin \alpha) - \frac{1}{2} w \rho^2 (\sin \phi - \sin \alpha)^2,$$

making  $Q = n \rho w a$ ,  $n$  being a number to be calculated, and recalling that  $W' = w \rho \sin \phi = w a$ , and substituting these values of  $Q$  and  $W'$  in the preceding expressions, there obtains

$$M = \frac{1}{2} w \rho^2 (\sin^2 \phi - \sin^2 \alpha) - 2 n w \rho^2 \sin \phi (\cos \alpha - \cos \phi);$$

and as  $\sin^2 \phi - \sin^2 \alpha = \cos^2 \alpha - \cos^2 \phi$ , there further obtains,

$$M = \frac{1}{2} w \rho^2 (\cos \alpha - \cos \phi) (\cos \alpha + \cos \phi - 4 n \sin \phi).$$

This expression reduces to zero for  $\alpha = \phi$ , as was to be expected, since the reactions of the support were supposed to be taken at the centres of elasticity of the extreme sections; it also reduces to zero for





$$\begin{aligned} \text{from } \alpha = 0 \text{ to } \alpha = \alpha_1 \dots \dots q &= \frac{E}{e} \left( -P + \frac{M h}{2 r^2} \right), \\ \text{from } \alpha = \alpha_1 \text{ to } \alpha = \phi \dots \dots q' &= \frac{E}{e} \left( -P - \frac{M h}{2 r^2} \right). \end{aligned}$$

If, on the contrary,  $n < \frac{1}{2} \cot \phi$ , it would mean that, even  $\alpha = \phi$ ,  $M$  would still be positive, and consequently that it be so throughout the arc. We would only have to examine the expression

$$q = \frac{E}{e} \left( -P + \frac{M h}{2 r^2} \right).$$

It is easy to see in these two cases the position occupied by the curve of pressure. In fact  $M$  is only the moment of the force applied to the centre of pressure, referred to the centre of elasticity in the same section. Then, from the known direction of  $P$  in a positive direction taken for  $M$ , we may conclude that if  $M$  is positive the curve of pressure lies above the mean fibre, and be  $M < 0$ .

We can now consider the principal question. There are two cases to be distinguished, when  $n > \frac{1}{2} \cot \phi$ , and when  $n < \frac{1}{2} \cot \phi$  for it has been shown that the maximum pressure in a given section is generally differently expressed in passing from one to the other of these cases.

The maximum pressure in a given section is expressed, then, by the following formulas:

$$\text{In the portion CH of the piece (Fig. F'); } q = \frac{E}{e} \left( -P + \frac{M h}{2 r^2} \right)$$

$$\text{In the portion HB } \dots \dots q' = \frac{E}{e} \left( -P - \frac{M h}{2 r^2} \right)$$

Substituting for  $P$  and  $M$  their values, in terms of  $\alpha$ , arranging the terms as respects the  $\cos \alpha$ , and placing  $1 - \cos^2 \alpha$  and  $\cos^2 \phi$  for  $\sin^2 \alpha$  and  $\sin^2 \phi$ , there obtains:

$$q = \frac{w \rho E}{e} \left[ \left( -1 + \frac{1}{2} \frac{\rho h}{r^2} \right) \cos^2 \alpha - \left( -1 + 2 \frac{\rho h}{r^2} \right) 2 n \sin \phi \cos \alpha + 1 + \frac{1}{2} \frac{\rho h}{r^2} \cos \phi (4 n \sin \phi - \cos \phi) \right]$$

$$q' = \frac{w \rho E}{e} \left[ - \left( 1 + \frac{1}{2} \frac{\rho h}{r^2} \right) \cos^2 \alpha + \left( 1 + \frac{1}{2} \frac{\rho h}{r^2} \right) 2 n \sin \phi \cos \alpha + 1 - \frac{1}{2} \frac{\rho h}{r^2} \cos \phi (4 n \sin \phi - \cos \phi) \right]$$

The greatest of the maxima of these two expressions must

obtained when  $\alpha$  varies between the limits in which they are applicable, viz., between 0 and  $\alpha_1$  for the first, and  $\alpha_1$  and  $\phi$  for the second.

To this end (Fig. F') it may be remarked in the first place that if  $q$  and  $q'$  are represented by the ordinates of two curves of which the corresponding values of the  $\cos \alpha$  are the abscissas, all the ordinates will be positive within the above limits. Moreover, these curves will be parabolas: the one belonging to  $q$  having its concavity uppermost, the other lowermost. This is easily seen, by recalling that  $r^2 < \frac{h^2}{4}$ ; whence  $\frac{1}{4} \frac{\rho h}{r^2} > \frac{\rho}{h}$ . On the other hand, as

$h$  can be but a small fraction of  $\rho$ , it follows that  $\frac{\rho}{h} - 1$ , and still

more  $\frac{1}{4} \frac{\rho h}{r^2} - 1$  are positive quantities. Hence the coefficient of  $\cos^2 \alpha$  is positive in the first equation, and negative in the second; therefore the two parabolas should have the above-mentioned position.

From this position, it can be at once seen that the greatest value of  $q$  should belong to one of the limits  $\alpha = 0$  or  $\alpha = -\alpha_1$ . The first will give

$$q_1 = \frac{w \rho}{e} E \left\{ 2n \sin \phi + \frac{1}{4} \frac{\rho h}{r^2} \sin \phi \left[ \sin \phi - 4n(1 - \cos \phi) \right] \right\},$$

or else, since  $\rho \sin \phi = \alpha$  and  $\frac{1 - \cos \phi}{\sin \phi} = \tan \frac{1}{2} \phi$ ,

$$q_1 = \frac{w \alpha}{e} E \left[ 2n + \frac{1}{4} \frac{\alpha h}{r^2} (1 - 4n \tan \frac{1}{2} \phi) \right]. \quad (1)$$

As to the value belonging to  $\alpha = \alpha_1$ , or to the point H, it cannot be considered here, for it will be found among the values of  $q'$ ; the point H belongs as much to the portion BH as the portion CH of the mean fibre.

The parabola belonging to  $q'$  turning its concavity to the axis of  $x$ , and having its ordinates positive, it is plain that the horizontal tangent will give the maximum, if it belongs to a value of  $\cos \alpha$  between the limits  $\cos \alpha_1$  and  $\cos \phi$ : the maximum must belong to one of these limits. Let us seek the condition for the first hypothesis. For this, let  $\alpha_1$  be the angle  $\alpha$  belonging to the horizontal tangent in question: this angle must satisfy the equation

$$\frac{dq'}{d \cos \alpha} = C$$

whence,

$$-(1 + \frac{1}{4} \frac{\rho h}{r^2}) \cos \alpha_1 + (1 + \frac{1}{4} \frac{\rho h}{r^2}) n \sin \phi = 0$$

or

$$\cos \alpha_2 + n \sin \phi \frac{1 + \frac{\rho h}{\frac{1}{2} r^2}}{1 + \frac{\rho h}{r^2}}.$$

This value will be true for

$$\cos \alpha_2 < \cos \alpha_1 \text{ and } \cos \alpha_2 > \cos \phi,$$

that is, substituting for  $\cos \alpha_2$  and  $\cos \alpha_1$  their values,

$$\begin{aligned} n \sin \phi \frac{1 + \frac{\rho h}{\frac{1}{2} r^2}}{1 + \frac{\rho h}{r^2}} &< 4 n \sin \phi - \cos \phi \\ n \sin \phi \frac{1 + \frac{\rho h}{r^2}}{1 + \frac{\rho h}{\frac{1}{2} r^2}} &> \cos \phi. \end{aligned}$$

Collecting in the first inequality the terms containing  $n$ , it

$$n \sin \phi \frac{3 + \frac{\rho h}{r^2}}{1 + \frac{\rho h}{\frac{1}{2} r^2}} > \cos \phi,$$

and, thus written, it is an evident consequence of the second latter gives

$$n > \frac{1}{2} \cot \phi \left( 1 + \frac{1}{1 + \frac{\rho h}{\frac{1}{2} r^2}} \right),$$

or

$$n > \frac{1}{2} \cot \phi \left( 1 + \frac{2 \sin \phi}{2 \sin \phi + \frac{\alpha h}{r^2}} \right) \quad (2)$$

The first principal case is characterized by the relation  $n > \frac{1}{2} \cot \phi$ ; but this inequality does not necessarily involve inequality because  $\frac{1}{2} \cot \phi$  is there multiplied by a factor greater than 1. This case must then be divided into two secondary cases.

1st. *The condition expressed by inequality (2) is satisfied.* The maximum pressure on the portion H B then belongs to  $\alpha = \alpha_1$ . It is found by the substitution of  $\cos \alpha$ , in the general expression for  $q'$ ; but to avoid a complicated calculation,  $\frac{\rho h}{r^2}$  being quite a large number, the value of  $\cos \alpha_1$ ,

$$\cos \alpha_1 = n \sin \phi \frac{1 + \frac{1}{2} \frac{\rho h}{r^2}}{1 + \frac{1}{2} \frac{\rho h}{r^2}}$$

will differ little from  $2 n \sin \phi$ , because there is no great error in suppressing the term 1 in the numerator and denominator of the fraction. Besides, when near a maximum, we can, without sensible alteration, take the value of the function corresponding to a value of the variable that is near the one giving the maximum. Substituting  $2 n \sin \phi$  for  $\cos \alpha$  in the expression for  $q'$ , and making  $\rho = \frac{\alpha}{\sin \phi}$ , we will find for the value of  $q'_1$  of the maximum in question

$$q'_1 = \frac{w \alpha E}{\sigma} \left[ \frac{1}{\sin \phi} + \frac{\alpha h}{r^2} (n - \frac{1}{2} \cot \phi)^2 \right]. \quad (3)$$

2d. *The inequality (2) is not satisfied.* Under this supposition, the parabola belonging to  $q'$  has not, in the portion considered, a horizontal tangent. The maximum, in this portion, belongs then to one of the two limits  $\alpha = \alpha_1$ , or  $\alpha = \phi$ .  $\cos \alpha_1$  is known from the equation

$$\cos \alpha_1 = 4 n \sin \phi - \cos \phi.$$

Substituting successively this value and  $\cos \phi$  in  $q'$ , which here reduces to  $-\frac{P E}{\sigma}$ , because M reduces to zero at the limits in question, we find two results,

$$q' = \frac{w \rho}{r^2} E [6 n \sin \phi \cos \phi - (8 n^2 - 1) \sin^2 \phi]$$

$$= \frac{w \alpha}{\sigma} E [6 n \cos \phi - (8 n^2 - 1) \sin \phi],$$

$$q_1 = \frac{w \alpha}{\sigma} E (2 n \cos \phi + \sin \phi). \quad \dots \quad (4)$$

It is easy to see that  $q'$ , the value belonging to  $\cos \alpha = \cos \phi$ , is greater than  $q''$ , for by subtraction

$$q' - q'' = 4n \frac{w\alpha}{e} E (2n \sin \phi - \cos \phi).$$

Besides, in the present case, we have  $n > \frac{1}{2} \cot \phi$  and, consequently,  $2n \sin \phi > \cos \phi$ , which proves the enunciation. In the second subdivision of the first principal case, the maximum pressure on the part H B, is at the point B, and is given by formula (4).

In whichever of the two subdivisions it is found, we must always, to obtain the greatest maximum sought, take the maximum in the portion C H, then in the portion H B, and choose the greater. The preceding discussion on the first principal case may be thus summed up:

*When  $n$  (the ratio of the thrust to the entire weight of the span) is greater than the limit indicated by inequality (2), the maximum pressure will be the greater of the two values given by the formulas (1) and (3), the first of which belongs to the extrados at the top, and the second to the intrados, at a point taken on the arc between the springing lines A, B and the crown C.*

*When  $n$  is included between the above limit and  $\frac{1}{2} \cot \phi$ , we must in the preceding rule substitute formula (4) for (3), which gives the maximum pressure at the joint of the springing lines.*

*Maximum pressure when  $n < \frac{1}{2} \cot \phi$ . In this case we have only to consider the expression*

$$q = \frac{E}{e} \left( -P + \frac{M h}{r^2} \right),$$

the maximum for which is to be found for  $\alpha$  varying from 0 to  $\phi$ . This expression is identical with that for  $q$  already used; if then the corresponding parabola be considered, we must conclude that the maximum for this expression must necessarily belong to one of the limits of  $\alpha$ . Besides  $\alpha = 0$  gives formula (1);  $\alpha = \phi$  gives formula (4), for  $M$  being zero,  $q$  and  $q'$  become equal. Hence the greater of the two values given by these formulas must be taken. Consequently there is no difference between the second principal case and the second subdivision of the first case.

The only cases to be distinguished are, then,  $n$  greater and  $n$  smaller than the limit given by formula (2): the first requiring the use of formulas (1) and (3), the second that of formulas (3) and (4).

In the preceding discussions, as the material is considered homogeneous throughout the cross-section,  $e$  is only the sum of the products of the superficial elements by the coefficient of longitudinal elasticity  $E$ , or  $E A$ , since  $E$  does not change from one fibre to another; hence

$$\frac{E}{\epsilon} = \frac{E}{EA} = \frac{1}{A}.$$

**Prob. 3.** *To find the changes in the versed sine, or rise, CD, (Fig E'), of the curve of the mean fibre from the action of the extraneous forces.*

Having determined, by the preceding calculations, the values of all the extraneous forces, the change in the dimensions of the rise of the arch can be found, and the now remaining problem resulting from their action be solved.

*Case 1.* Let the beam, in the first place, be taken as subjected to a strain arising from a weight uniformly distributed along the mean fibre. The action of this weight, supposing the extremities of the curve at A and B to be fixed, would be to press the crown at C downwards, and thus change the length of the rise CD; or, supposing the curve to be firmly fixed at C and to be left free at B, to change the position of B vertically in relation to C. The amount of this vertical change in the position of B is given for any point from B to C in the foot-note to p. 597-8, and is equal to  $(a - x) \alpha$ : in which, according to the notation used in the preceding problems,  $\alpha$  is the infinitely small angle between two consecutive normals, and  $(a - x)$  is the abscissa of the point considered; DY and DX being the axes of co-ordinates.

Resuming the Eqs. (K) and (A), and representing by  $\Delta f$  the change in length of the rise, there will obtain, to express this quantity,

$$\Delta f = \int_0^a \left\{ \frac{M(a-x) ds}{\epsilon} + \frac{P}{\epsilon} dy \right\} = \int_0^a \left\{ \frac{M(a-x) ds}{\epsilon} \frac{dx}{dx} + \frac{P dy}{dx} \right\} dx. \quad (X')$$

Now M, as in the preceding propositions, represents the sum of the moments of all the extraneous forces, including those of the reactions at the points of support; and P the sum of the components of the same forces perpendicular to the plane of the joint considered; or, in other words, the sum of the projections of these forces on the tangent to the mean fibre at the point whose abscissa is  $(x - a)$ , and ordinate  $y$ .

As in the preceding propositions, so all the variables in the preceding expression (X') will be expressed in that of one alone, which is that of  $\alpha$ , the angle that any assumed radius OI makes with the axis OY.

Denoting, as before, by  $\theta$ , the value of  $\alpha$  for any joint OE; and by  $w$  the weight of the load uniformly distributed over ACD for each unit of length of the curve, there will obtain:

$w \rho d\theta$ , to express the weight on the element  $s d\theta$ ;  
 $w \rho \phi$ , for the vertical reaction at the point B;  
 $w \rho \phi (\rho \sin \phi - \rho \sin \alpha) = w \rho^2 \phi (\sin \phi - \sin \alpha)$ , for the moment of the reaction due to the weight of the portion I B of the arc

$$- \int_{\alpha}^{\phi} w \rho d\theta (\rho \sin \theta - \rho \sin \alpha), \text{ for the moment of the weight}$$

of the portion I B;

$- Q (\rho \cos \alpha - \rho \cos \phi)$ , for the moment of the horizontal reaction at B;

Therefore, there obtains, to express M,

$$M = - \int_{\alpha}^{\phi} w \rho^2 (\sin \theta - \sin \alpha) d\theta + w \rho^2 \phi (\sin \phi - \sin \alpha) - (\cos \alpha - \cos \phi).$$

In like manner, there obtains,

$$P = - Q \cos \alpha - w \rho \phi \sin \alpha + w \rho (\phi - \alpha) \sin \alpha.$$

By reduction, M and P become respectively

$$M = - w \rho^2 (\cos \alpha - \cos \phi + \alpha \sin \alpha - \phi \sin \phi) - Q \rho (- \cos \phi);$$

$$P = - Q \cos \alpha - w \rho \alpha \sin \alpha.$$

Now expressing  $x, y, ds$  &c., in terms of  $\alpha$ , there obtains  
 $x = \rho \sin \alpha, y = \rho (\cos \alpha - \cos \phi), dx = \rho \cos \alpha d\alpha, dy = \rho \sin \alpha d\alpha,$

$$ds = \rho d\alpha, a = DB = \rho \sin \phi.$$

Substituting these values in Eq. (X'), there obtains,

$$\begin{aligned} - \Delta f &= \frac{w \rho^4}{\epsilon} \int_0^{\phi} (\sin \alpha - \sin \phi) (\cos \alpha - \cos \phi + \alpha \sin \alpha \\ &\quad \sin \phi) d\alpha \\ &+ \frac{Q \rho^3}{\epsilon} \int_0^{\phi} (\sin \alpha - \sin \phi) (\cos \alpha - \cos \phi) d\alpha \\ &+ \frac{w \rho^3}{\epsilon} \int_0^{\phi} \alpha \sin^2 \alpha d\alpha + \frac{Q \rho}{\epsilon} \int_0^{\phi} \sin \alpha \cos \alpha d\alpha. \end{aligned}$$

From the reductions required in the algebraic operation the preceding propositions, all the differential monomials in foregoing value of  $-\Delta f$  can be readily integrated, and

$$\int_0^{\phi} \alpha \sin^2 \alpha \, d\alpha, \text{ (*)}, \text{ which becomes by integration,}$$

$$-\frac{1}{2} \alpha \sin \alpha \cos \alpha + \frac{1}{4} \sin^2 \alpha + \frac{1}{4} \alpha^2.$$

Performing then the algebraical operations indicated, there obtains,

$$-\Delta f = \frac{w \rho^4}{\epsilon} \left( -\frac{9}{4} \sin^2 \phi + \frac{5}{2} \phi \sin \phi \cos \phi + 1 - \cos \phi - \phi \sin \phi \right. \\ \left. + \phi^2 \sin^2 \phi + \frac{1}{4} \phi^3 \right) \\ - \frac{Q \rho^3}{r} \left( \frac{3}{2} \sin^2 \phi - \phi \sin \phi \cos \phi + \cos \phi + 1 \right) \\ + \frac{w \rho^2}{4 \epsilon} \left( -2 \phi \sin \phi \cos \phi + \sin^2 \phi + \phi^2 \right) + \frac{Q \rho}{2 \epsilon} \sin^2 \phi, \text{ (x)}$$

When the arc  $\phi$  is small, which is usually the case within the ordinary limits of practice, the preceding expression, by suitable reductions, the details of which cannot be entered into here, reduces to

$$-\Delta f = 1.56 \frac{w \rho^2}{\epsilon \left( 1 + \frac{15 \rho^2}{8 f^2} \right)} \left( 1 + 0.0081 \frac{f^2 \rho}{a^2 r^2} \right). \text{ (x')}$$

Although the preceding expression has been constructed under the supposition that  $\phi$  is quite small, and the arch very flat, in which case  $\phi \rho = a$ , and  $\phi = 2 \tan \frac{1}{2} \phi = \frac{2f}{a}$ , it will still give approximate values of no very considerable errors when  $\phi = \frac{\pi}{2}$ , in which case  $f = a = \rho$ , and the preceding expression becomes

$$-\Delta f = \frac{w \rho^2}{\epsilon \left( 1 + \frac{15 \rho^2}{8 f^2} \right)} \left( 1.56 + 0.0127 \frac{\rho^2}{r^2} \right), \text{ (x'')}$$

*Case 2. To find the changes in the versed sine of the curve when the weight, or load, is uniformly distributed over the chord, or span of the curve.*

In this case, as the weight is uniformly distributed along the

---

(\*) For this integration see Church's *Calculus*, art. 169, p. 284, and art. 190, p. 264.



span, calling  $w'$  the weight on the unit of length of the span on any portion of it, denoted by  $l$ , and which acts perpendicular to it, will be  $w' l$ .

Adopting the same notation, only changing  $w$  into  $w'$ , as in the preceding case, there obtains,

$$-\frac{1}{2} w' \rho^2 (\sin \phi - \sin \alpha)^2,$$

for the moment of the portion of the weight distributed over the portion of the arc which corresponds to I B;  $w' \rho^2 \sin \phi (\sin \alpha)$ , for the moment of the vertical reaction at B;

$- Q \rho (\cos \alpha - \cos \phi)$ , for the moment of the horizontal reaction at the point B.

Therefore, to express M, there obtains,

$$M = -\frac{1}{2} w' \rho^2 (\sin \phi - \sin \alpha)^2 + w' \rho^2 \sin \phi (\sin \phi - \sin \alpha) - Q \rho (\cos \alpha - \cos \phi);$$

in which expression that value of Q (Eq.  $t'$ ) which has been taken for the horizontal thrust when the weight is uniformly distributed along the span must be here taken.

Substituting in Eq. (X'), and going through a series of operations and reductions in all respects analogous to the preceding case, there obtains,

$$-\Delta f + 1.56 \frac{w' \rho^2}{a \left(1 + \frac{15 r^2}{8 f^2}\right)} \left(1 + 0.0122 \frac{f^4}{a^3 r^2}\right). \quad (y')$$

From calculations made of the exact values of  $\Delta f$  for  $\frac{\pi}{2}$  as  $\alpha$  it has been found, that the one given by the preceding expression (y') will be very nearly exact for  $\frac{\pi}{4}$ ; but that for  $\frac{\pi}{2}$  the result will be noticeably too great, but still will not increase  $\Delta f$  more than 40 per cent. of its true value.

*Table of the average values of the Moduli E and G.*

Average values for E, the modulus or coefficient of longitudinal elasticity for some of the more common building materials.

Cast-iron .....	E = 17,000,000 lbs. per square i
Wrought-iron bars and bolts. .	29,000,000 " " "
Wrought-iron wire.....	25,300,000 " " "
Steel bars.....	31,500,000 " " "
Pine timber.....	1,600,000 " " "
Oak timber.....	1,700,000 " " "

Average values of  $G$ , the modulus or coefficient of lateral elasticity.

Cast-iron.....	$G = 2,850,000$ lbs. per square inch.				
Wrought-iron.....	9,000,000	"	"	"	"
Pine timber.....	89,000	"	"	"	"
Oak timber.....	82,000	"	"	"	"

For fuller developments of the subject of this Note, see Moseley: *Mechanical Principles of Engineering and Architecture*. Navier: *Cours de Mécanique Appliquée*. Bresse: *Cours de Mécanique Appliquée*.



# INDEX.

---

- ABRASION**, comparative resistance of stone to, 17  
**Abutment piers**, 295  
**Abutments**, 248  
     " how strengthened, 258  
     " of domes, 258  
     " of iron bridges, 325  
     " of suspension bridges, 363  
     " of wooden bridges, 310  
**Accessory works of a canal**, 488  
**Action of frost on masonry**, 261  
**Adherence of mortar**, 73  
**Adhesion of iron spikes**, 170  
**Adie**, effect of temperature on stone, 115  
**Agaric mineral**, 79  
**Air**, compressed, use of, 229  
**Air-lime**, 18  
**Air-locks**, double, 224  
**Air-slaking**, 88  
**Albany**, the capitol at, 239  
**Algiers**, mole at, 538  
**Alleghany river bridge**, 344  
**Alloys for preserving iron**, 96  
**American bridges**, 307  
     " iron bridges, 326  
     " wooden bridges, 324  
**Analyses of magnesian limestones**, 22  
     " of puzzolana, etc., 43  
**Analysis of Chittenango hydraulic limestone**, 21  
     " of Manlius hydraulic limestone, 20  
     " of Ulster County hydraulic limestone, 21  
**Angle of deflection of rails**, 437  
     " of repose, 407  
**Annular arch**, 250  
**Appendix**, 545  
**Approaches of a bridge**, 305  
**Aqueduct**, 279  
     " bridge, 279  
     " bridges, 391  
     " of Fontainebleau, 187  
     " Potomac, 298, 308, 212  
**Aqueducts**, canal, 489  
**Arch braces**, 320  
**Arch**, centring the, 289  
     cylindrical, 284  
     " inverted, or counter, 237  
     " lines of the, 283  
     " stones, 248  
     " surfaces of the, 282  
     " triumphal, 362  
     " volumes of the, 288  
**Arched bridges**, 289  
     " truss, 337  
**Arches**, 248  
     " classification, 282  
     " cloistered, 258  
     " iron, 327  
     " masonry of, 258  
     " oblique, 285  
     " relieving, 245  
     " rupture of, 257  
     " settling of, precautions  
         against, 258  
     " wooden, 277, 321  
**Architecture for bridges**, 294  
     " of bridges, 307  
**Areas**, 239  
     " strain on unit of, 524  
**Arenes**, 48  
**Argillaceous sands**, 48  
     " stones, 8  
**Artificial hydraulic limes**, 41  
     " puzzolanas, 43  
     " stone, Ransome's, 63  
**Asphalte in masonry**, 255  
**Asphaltic roadways, etc.**, 427  
     " pavements, 421  
**Asphaltum**, 75  
**Attrition**, resistance of stone to, 16  
  
**BACKING**, in masonry, 174  
**Backs**, in masonry, 174  
**Ballast**, advantage of, 445  
     " for railroad, 434  
**Baltimore and Ohio R. R. grade**, 439  
**Bands**, flexible, for inclined planes, 439  
**Banks**, protecting, of rivers, 496  
**Barlow**, experiments on wrought iron, 154  
     " experiments with bar iron, 148  
     " on elasticity of iron, 107

- Barlow, resistance of timber to de-  
trusion, 130  
" strain of timber, 122  
" strength of timber, 120  
Barking trees, 80  
Barracks of Notre Dame, 188  
Bars, cast iron, effect of horizontal  
impact on, 144, 145  
" of rivers, 494  
" of wrought iron, strength of,  
148  
" river, 502  
Bartlett, effect of temperature on  
stone, 114  
Basins, 541  
Batter, or bâtir, 174  
Bays in bridges, 282  
" of suspension bridge, 357  
Beam, cast iron, form to resist trans-  
verse strain, 141  
" a straining, 272  
Beams, 263, 265  
" cast iron, rules to determine  
strength, 143; curved, 595  
" deflection of wooden, 128  
" fishing a, 268  
" iron, influence of form, 188  
" joints of, end to end, 268  
" open-built, 271  
" problems on, 564  
" supported and acted on by  
pressure, 564  
Bearing, the, 265  
Bear-trap gate, 554  
Bed of the foundation, 190  
" or build, in masonry, 175  
Bed-plates, experiments on, 454  
Belgian system of canal locomotion,  
493  
Bell-metal, 98  
Benches of a road, 412  
Berlin castings, polish for, 102  
Best pavement, 421  
Beton, 46, 60  
" agglomerate, 64, 187  
" strength of, 118  
*Beton-Cointet*, 62  
Binder, a, in masonry, 178  
Birdseye marble, 10  
Bituminous mastic, 74  
Boat-bridge, 391  
Boiler iron, strength of, 148  
Bollman's truss, 337  
Bonds in brickwork, 184  
" in masonry, 179  
Bordeaux bridge, 309  
Boucherie, preserving timber, 84  
" seasoning timber, 81  
Boulogne artificial hydraulic cement  
42  
Boulogne pebbles, 20  
Braces, 264  
" for detached frames, 395  
Bracket scaffolding, 185  
Brard, effects of frost on stone, 14  
Bramah's table of strength of stone,  
110  
Brass, 98  
" strength of, 167  
Breakage of steel rails, 464  
Breakers, ice, 318  
Breaking strain of wrought iron,  
152  
" weight of iron tubes, 354  
Break-joints in masonry, 178  
Breakwater, Algiers, 538  
" Delaware, 587  
" of Cherbourg, 536  
" of Plymouth, 587  
Breakwaters, 536  
Brecciated porphyry, 5  
Briare canal, 475  
Brick, 76  
" making, 77  
" masonry, 188  
Bridge, Alleghany River, 344  
" at Leavenworth, 229  
" at Nantes, 231  
" at Omaha, 229  
" at Szegedin, 227  
" Britannia tubular, 350  
" built by Rendel, 309  
" Coalbrookdale, 326  
" definition of a, 279  
" East River, 229, 234, 379  
" frame, ribs in a, 322  
" Fribourg, 370  
" Grosvenor, 290  
" Harlem, 226  
" Kulenberg, 347  
" Linville, 334  
" Louisville, 339  
" Menai, 368  
" Monongahela, 373  
" New London, 301  
" Niagara, 374  
" nomenclature, 314  
" of Bordeaux, 309  
" of Neuilly, 295  
" over the Dordogne, 308  
" over the Lary, 309  
" over the Patapsco, 307  
" over the Savannah, 229  
" over the Scorf, 230  
" over the Theiss, 237  
" over the Tweed, 368

- Bridge, Post's combination, 343**  
 " " iron, 340  
 " Schuylkill, 317  
 " Seekonk River, 201  
 " Southwark, 326  
 " Staines, 326  
 " St. Louis, 281  
 " St. Louis and Illinois, 344  
 " Sunderland, 326  
 " swing, Providence, 385  
 " Tewksbury, 326  
 " Victoria, 354, 212  
 " Waterloo, 292  
**Bridges, 279**  
 " American, 307  
 " approaches of, 305  
 " aqueduct, 391  
 " arched, 289  
 " architecture, 307  
 " bays in, 282  
 " boat, 391  
 " canal, 490  
 " cast iron, 325  
 " celebrated wooden, 324  
 " construction of, 294  
 " draw, 381  
 " effect of temperature on, 331  
 " English, 307  
 " " iron, 326  
 " French, 307  
 " " iron, 326  
 " iron, American, 326  
 " " European, 327  
 " " trussed, 332  
 " location of, 280  
 " movable, 380  
 " of N. Y. State canal, 321  
 " piers for, 295  
 " rolling, 380, 391  
 " stone, 279  
 " " of Europe, 308  
 " style of architecture, 294  
 " superstructure of, 302  
 " suspension, 357  
 " tubular, 347  
 " turning, 394  
 " water wings of, 306  
 " wing-walls, 299  
 " wooden, 310  
 " wrought iron, 347  
**Bridle pieces, 274**  
**Britannia tubular bridge, 350**  
**Broken-stone road covering, 423, 425**  
**Bronze, 98**  
**Brown, tensile strength of cast iron,**  
 131  
 " Tweed bridge, 368  
**Brunel, experimental arch, 184**  
**Brunel, Hungerford bridge, 371**  
**Buck's system, 286**  
**Buhr, 7**  
**Building materials, 3**  
**Built beam, 265**  
**Burnetizing, 83**  
**Burning brick, 78**  
**Burr's truss, 318**  
**Buttresses, 205**  
**CABLES of suspension bridges, 360**  
**Caisson dams, 212-217**  
 " (in arches), 255  
 " pneumatic, 229  
**Calcareous sands, 48**  
 " stones, 9  
**Calcination of limestone, 25, 36**  
**Calculation of solid contents, 409**  
**Caledonian canal, 491**  
**Canal aqueducts, 489**  
 " aqueduct bridges, 392  
 " Briare, 475  
 " bridges, 490  
 " bridges of N. Y. State, 321  
 " Caledonian, 491  
 " Chenango, 476  
 " culverts, 489  
 " Erie, 493  
 " feeders, 474  
 " gauging for a, 475  
 " lock, 472  
 " lock-gates, 487  
 " locks, 482  
 " locks, lift of, 479  
 " reservoirs, 474, 476  
 " Rideau, 492  
 " temporary dams, 490  
 " tide-lock, 490  
 " waste weir, 490  
 " Welland, 492  
**Canals, 467**  
 " accessory works of, 466  
 " cross-section of, 470  
 " embankments of, 469  
 " English, 491  
 " experiments on, 472  
 " French, 492  
 " in U. S., 487  
 " Languedoc, 475  
 " leakage of, 472  
 " levels of, 480  
 " location of, 469  
 " locomotion on, 493  
 " the St. Lawrence, 492  
 " water-supply of, 471  
**Capitol at Albany, 289**  
 " roof of, at Montpellier, 400, 403

- Capping, 255  
 Carpentry, 263  
 Carrollton, viaduct, 308  
 Cast-iron bars, effect of horizontal  
   " impact on, 144, 145  
   " beam, form of to resist  
     transverse strain, 141  
   " bridges, 325  
   " edge rail, 431  
   " for building, 89  
   " lockers for, 101  
   " strength of, 131  
 Catch-water drains, 418  
 Cedar, 88, 89  
 Cement, hydraulic, 18, 19, 20, 49  
   " injected into masonry, 261  
   " limestones, 18  
   " Portland, 20  
   " Portland, strength of, 117  
   " Roman or Parker's, 12  
   " Roman, strength of, 118  
 Cements, artificial hydraulic, 41  
   " hydraulic, tables of, 20  
 Central Pacific grade, 439  
 Centre of elasticity, 562  
 Centres of arches, 289  
 Chains of suspension bridges, 360  
 Chaley, Fribourg bridge, 370  
 Characters of good brick, 78  
   " of hydraulic limestones,  
     23  
 Chenango canal, 476  
 Cherbourg breakwater, 536  
 Chestnut, 88  
 Chittenango hydraulic limestone, 21  
 Church of beton agglomerate, 187  
 Clarke, frame for concrete, 186  
 Clark, resistance of iron to shearing  
   strain, 161  
 Classification of arches, 282  
   " of masonry, 174  
   " of soils, 190  
 Cleaning roads, 429  
 Cloistered arches, 258  
 Close joints in masonry, 177  
 Coalbrookdale bridge, 326  
 Coal-tar for masonry, 260  
 Coefficients of linear expansion, 167  
 Cofferdams, 208, 212  
 Coffers, strength of, 166  
 Coignet-beton, 187  
   " proportions for, 189  
 Coignet, church built by, 188  
 Coignet's mill, 54  
 Coloring timber, 85  
 Columns, cylindrical, resistance of,  
   132  
 Common limestone, §
- Common mortar, 46  
 Compact limestone, 9  
 Comparative strength of iron, steel,  
   and hemp rope, 156  
 Component parts of structures, 238  
 Composite locks, canal, 487  
   " posts, bridge, 342  
 Compressed air for tunnelling, 442  
   " use of, 229  
 Compressible soils, foundations in,  
   192  
 Compression, resistance of cast iron  
   to, 131  
   " resistance of wrought  
     iron to, 154  
 Compressing roads, 427  
 Compressive strain, resistance of  
   timber of, 123  
 Conclusions on strength of wrought  
   iron, 149  
 Concrete, 46, 59  
   " Clarke's frame for, 186  
   " durability of, 71  
   " walls, 185  
   " strength of, 118  
 Conglomerate marble, 10  
 Conoidal arch, 250  
 Constable, embankment walls, 242  
 Construction of bridges, 294  
   " masonry, 236  
 Contents, solid, of a road, 409  
 Contraction of solids, 106  
 Copal varnish, 101  
 Copper, 98  
   " strength of, 166  
 Corbels, 272  
 Coriolis, table of wear of stone, 17  
 Corrugated iron, 97  
 Counter-arch, 237  
   " currents, 504  
 Counterforts, 244  
 Country roads, 425  
 Course, in masonry, 174  
 Courses, foundation, 236  
 Coursing joints, 286  
 Covered drains, 417  
 Covering of road, broken stone, 423,  
   425  
 Coverings, road, 419  
 Cramping metal, a, 99  
 Crib-work, 310  
   " coffer-dams, 212  
 Cross dimensions of roads, 429  
   " mitre drains, 418  
   " section of a canal, 47C  
   " strains, frames for, 264  
   " tie for railroad, 434  
 Crossing-places, 423

- Crossing-plate, 437  
 Crossings of railroads, 436  
 Crushing force, measure of, 108  
 Cubical stone pavement, 422  
 Culvert of canal reservoir, 478  
 Culvert, 417; canal, 489  
 Curb-stones, 423  
 Currents, 534  
 Curtois on puzzolanas, 45  
 Curved beams, 595  
 Curves of railroads, 436  
 Cut stone, 174  
 Cylindrical arch, 284  
 Cylindrical columns, resistance of, 132  
 Cypress, 89  
  
**DAMS**, coffer, 208, 212  
     " of canal reservoirs, 476  
 Dangerous section, 555  
 Daniel and Wheatstone, strength of stone, 112  
 Deductions from experiments as to strength of stone, 113  
 Deductions from Von Weber's experiments, 461  
 Dee, bridge over the, 290  
 Defects of timber, 82  
 Definitions in bridge nomenclature, 314  
     " in masonry, 174  
 Deflection, angle of, of rails, 437  
     " of wooden beams, 128  
 Deflections, effects of time on, 136  
 Delafield, tubular ribs, 328  
 Delaware breakwater, 537  
 Delta of rivers, 495  
 Depot roof truss, 399  
 Desfontaines dam, 526  
 Destroyers of timber, 86  
 Deterioration of hydraulic cement, 40  
 Detrusion, resistance of timber to, 130  
 Dikes, 542  
     " longitudinal, on rivers, 499  
 Dimensions, cross, of roads, 429  
     " of a lime-kiln, 29  
     " of a wall, 240  
 Disk piles, 197  
 Distributing canal reservoir, 476  
 Docks, wet, 541  
 Dolomites, 10  
 Dome, 251  
 Domes, abutments of, 253  
     " and roofs, 400  
 Dordogne, bridge over the, 303  
 Double air-locks, 224  
  
 Dove-tail joint, 271  
 Drainage of a road, 413, 416  
 Drain in tunnels, 442  
 Drains, 417, 418  
 Draught, prism of, 474  
 Draw-bridges, 331  
 Dredge, chains of suspension bridges, 363  
 Drift in a tunnel, 440  
 Drip of a bridge, 302  
 Driver, pile, 197, 198  
 Drying brick, 78  
 Dufour, experiments relative to suspension bridges, 367  
 Duleau on elasticity of iron, 106  
 Dunlop, resistance of iron to torsion, 162  
 Durability of concrete, 71  
     " of iron, 94  
     " of mortars, 57  
     " of rails, 433  
     " of stone, 13  
     " of suspension bridges, 367  
     " of timber, 86  
 Dutch dikes, 542  
  
**EARLE'S** method for preserving timber, 84  
 Earthen dams, 476  
 Earth for brick, 77  
 Earth-work of a road, 411  
 East River bridge, 229, 234, 379  
 Edge-rails, 431  
 Effect of horizontal impact on cast-iron bars, 144, 145  
     " of temperature on copper, 167  
     " of temperature on masonry, 261  
     " of trains on sleepers, 448  
     " of speed on roads, 443  
 Effects of bed-plates, 454  
     " of frost on stone, 14  
     " of heat on stone, 15  
     " of temperature on bridges, 331  
     " of temperature on iron, 137  
     " of temperature on tensile strength of wrought iron, 158  
     " of time on elongation of wrought iron, 155  
     " of time upon deflections, 136  
 Elasticity, centre of, 562  
     " lateral and longitudinal, 561  
     " limits of, 106  
 Elbow-joint, 252  
 Elbow-joints in masonry, 176



- Elbows of rivers, 494, 497  
 Elongation of wrought iron, 155  
 Embankment of canals, 469  
   " wall for, 240  
   " of roads, 409, 414  
 Embankments, settling of, 414  
 Emy on waves, 535  
 Enclosure, walls of, 238  
 Engines, pile, 197  
 England, pavements of, 421  
   " piles in, 208  
 English bond in brick-work, 184  
   " bridges, 307  
   " canals, 491  
   " iron bridges, 326  
 Enlargement of water way, 306  
 Erie canal, 473, 493  
 Europe, beton agglomeré in, 187  
   " stone-bridges of, 308  
 European iron bridges, 327  
   " wooden bridges, 324  
 Excavations for a road, 411  
 Expansion, linear, 167  
   " of stone, 114, 115  
 Experiments of Von Weber on rails, 442  
   " on bars of hot blast-iron, 139, 140  
   " on bed-plates, 454  
   " on canals, 472  
   " on cast-iron bar by impact, 144, 145  
   " on force of traction, 407  
   " on permanent ways, 444  
   " on strength of frames, 274  
   " on strength of materials, 104  
   " on suspension bridges, 367  
   " on transverse strength of cold-blast iron, 136  
   " on tube for bridge, 350  
   " on wrought-iron, 154  
 Extension of solids, 106  
   " resistance of cast-iron to, 181  
 FACE, in masonry, 174  
 Facing, in masonry, 174  
 Fairbairn, effects of time on deflections of horizontal bars, 136  
   " experiments on plate iron, 147  
   " on cast-iron, 92  
   " ratio of resistances of hot and cold blast iron, 146  
   " strength of steel, 164  
 Fairbairn, tenacity of iron, 138  
   " tubular bridges, 348  
 Fascines, 419  
 Fat limes, 18  
 Features of rivers, 494  
 Feeders, canal, 474  
 Felling trees, 80  
 Fender-beams, 311  
 Fender for bridge piers, 285  
 Filling, in masonry, 174  
 Fink truss, 338  
 Finlay, suspension bridges, 357  
 Fire-brick, 79  
 Fire-stone, 7  
 Fish-bellied rail, 431  
 Fishing a beam, 268  
 Fisk, experiments on canals, 473  
 Flagging, 7, 8  
 Flash pointing, 260  
 Flemish bond in brick-work, 184  
 Flexible bands, for inclined planes, 439  
 Folding wedges, 266  
 Fontainebleau, aqueduct of, 187  
 Force, shearing, 560  
   " of the wind, 394  
   " of traction, 407  
   " to draw spikes out of sleepers, 456  
 Forces and strains, relations between, 563  
 Forest trees, 86  
 Form, influence of, on cast-iron beams, 138  
 Form of a lime-kiln, 29  
   " of a wall, 240  
   " of cast-iron beam to resist transverse strain, 141  
   " of section of retaining walls, 243  
   " sand, for pavements, 421  
 Formula for breaking-weight of iron tubes, 354  
 Foundation courses, 236  
   " definition of, 190  
 Foundations by pneumatic processes, 220  
   " double air-locks for, 224  
   " in compressible soil, 193  
   " in marshy soils, 193  
   " lateral yielding of, 204  
   " of land structures, 190  
   " of structures in water, 208  
   " on piles, 196  
   " rock, 191  
   " sand, 193

- Foundations, sand for, 203**  
 " stony ground, 191  
**Fox, iron trussed bridges, 333**  
**Frame, a, 263**  
 " bridge, ribs in a, 323  
**Frames for cross-strains, 264**  
 " strength of, 274  
**Framing, 263**  
 " for intermediate supports, 272  
**France, pavements of, 423**  
 " pile-driving in, 200  
 " tubular ribs in, 329  
**Freestone, 7**  
**French bridges, 307**  
 " canal feeders, 475  
 " canals, 492; dikes, 543  
 " engineers, on roads, 426  
 " experiments on strength of frames, 274  
 " iron bridges, 326  
 " method for leaks in walls, 260  
 " mortars and cements, 50  
**Fribourg bridge, 370**  
**Frost, action on masonry, 261**  
 " action on stone, 14  
**Frost's table of comparative resistance of abrasion, 17**  
*Fucoides demissus, 10*  
**Fuel for lime-burning, 27**  
**Funk's experiments on railway spikes, 451**  
  
**GALVANIZING iron, 95**  
**Gas-houses, roofs of, 397**  
**Gates, canal lock, 487**  
**Gauge of a railroad, 435**  
**Gauging for a canal, 475**  
**Gillmore, on Hoffman lime-kiln, 34**  
**Girard dam, 530**  
**Girdling trees, 80**  
**Gneiss, 6**  
**Grade of railroads, 439**  
**Gradients, 405**  
 " railroads, 438, 439  
**Grand Trunk road, 432**  
**Granite, 6**  
**Grant, on Telford, etc., roads, 425**  
 " strength of Portland cement, 117  
**Granular limestone, 9**  
**Gravel roads, 425**  
**Graywacke slate, 8**  
**Great Western Railway, 432**  
**Greenstone, 5**  
**Grillage, a, 193**  
**Groins, seaconst, 543**  
**Grosvenor bridge, 290**  
  
**Grout, 46**  
**Guard for bridge piers, 295**  
 " lock of a canal, 490  
**Gun-metal, 98**  
**Gunpowder pile-driver, 198**  
**Gypsum, 13**  
  
**HALL's method for arches, 288**  
**Harbors, 538**  
**Harlem bridge, 226**  
**Headers in masonry, 177**  
**Heading in a tunnel, 440**  
**Heat, effects on stone, 15**  
**Hodgkinson, on blast for cast-iron, 91**  
 " on cylindrical columns, 132  
 " on elasticity of cast iron, 106  
 " on pillars, 135  
 " ratio of resistances of hot and cold blast iron, 146  
 " resistance of iron wire to impact, 161  
 " resistance of square pillars, 123  
**Hodgkinson's experiments on plate iron, 147**  
 " form of iron beams, 138  
 " formula for strength of cast-iron beams, 143  
 " measure of crushing force, 108  
 " strain of timber, 122  
 " strength of cast-iron, 131  
**Hoffman lime-kiln, 34**  
**Hoosac tunnel, 442**  
**Horizontal bars, deflections of, 136**  
**Horizontal thrust, 600**  
**Hornblende slate, 8**  
**Horn-stone, 7**  
**Hot-blast, economy of, 91**  
**Howe's truss, 317**  
**Hudson, wing-walls on, 499**  
**Hungerford bridge, 371**  
**Hydraulic cement, 18, 19, 20, 49**  
 " cements, table of, 20  
 " lime, 18, 19, 20  
 " limes, artificial, 41  
 " limes, most suitable, 65  
 " limestone, 11, 12, 18  
 " limestones, characters and tests of, 23  
 " mortar, 46, 48

- ICE-BREAKERS**, 313  
 Ice, to guard bridges against, 208  
 Improved traction in steel rails, 465  
 Improvements of rivers, 495  
     " of steel rails, 465  
     " seacoast, 534  
**Inclined planes**, 439  
     " streets, 272  
**Increasing strength of retaining-walls**, 244  
**Influence of form on cast-iron beams**, 138  
**Injecting cement into masonry**, 261  
**Injury of mortar**, 51  
**Intermittent lime-kilns**, 28  
**Inundations, measures against**, 498  
**Inverted arch**, 237  
**Iron arches**, 327  
     " bridge at Staines, 331, 332  
     " bridge, Post's, 340  
     " bridges, European, 327  
     " cast, 89  
     " cast, bridges, 325  
     " cast, strength of, 131  
     " cold blast, strength of, 136  
     " corrugated, 97  
     " durability of, 94  
     " effects of temperature on, 137  
     " for building, 89  
     " neutral axis of, 107  
     " piles, 203  
     " pillars, 134  
     " protection of, 94, 95  
     " rails, 431  
     " resistance to shearing strain, 161  
     " roof trusses, 396  
     " spikes, adhesion to timber, 170  
     " steely, 98  
     " trussed bridges, 332  
     " tubes, breaking-weight of, 354  
     " wire, resistance to impact, 161  
     " wrought, 92  
     " wrought, effects of temperature on, 158  
     " wrought, elongation of, 155  
     " wrought, Kirkaldy's conclusions on strength of, 149  
     " wrought, resistance to compression, 154  
     " wrought, resistance to transverse strain, 154  
     " wrought strength of, 147  
     " wrought, thermo-tension of, 161  
**JAPAN varnish**, 101  
**Jervis, experiments on canals**, 472  
     " on canal reservoirs, 476  
**Jetties**, 538  
**Johnson, adhesion of iron spikes**, 176  
     " effects of thermo-tension, 161  
**Joint, dove-tail**, 271  
     " elbow, 252  
     " scarf, 268  
**Joints**, 264, 267  
     " coursing, 286  
     " in masonry, 175  
     " mortise and tenon, 270  
     " of beams end to end, 268  
     " rail, 464  
     " tie, 271  
**Joists**, 264  
**Juniper**, 89  
**KEYS**, 266  
**Kilns, lime**, 27  
**King-bolt**, 266  
     " post, 273  
**Kirkaldy, effect of heat on wrought iron**, 161  
     " experiments on wrought iron, 149  
     " strength of steel, 164  
**Kullenberg bridge**, 347  
**Kyanizing**, 83  
**LACKERS for cast iron**, 101  
**Land-locked roadstead**, 536  
**Land structures, foundations of**, 190  
**Languedoc canal**, 475  
**Larch**, 88  
**Larmier of a bridge**, 302  
**Lary, bridge over the**, 309  
**Lateral forces, resistance of rail to**, 442  
     " yielding of foundations, 204  
**Latrobe, bridge built by**, 307  
**Lattice truss**, 316  
**Lead**, 99  
     " strength of, 167  
**Leakage of a canal**, 472  
**Leaks in walls**, 260  
**Leaning retaining-wall**, 243  
**Leavenworth bridge**, 229  
**Levels of canals**, 480  
**Lewis, a, in masonry**, 183  
**Lift of canal locks**, 479  
     " prism of, 474  
**Lighthouse of Port Said**, 187  
**Lime**, 18.  
     " burning in U. S., 81.  
     " kilns, 27.  
     " stone, 9.  
**Limes, hydraulic, most suitable**, 65  
**Limestone, calcination of**, 25.  
**Limits of elasticity**, 106.

- Limits of resistance on the unit of area to a strain, 562  
 Linear contraction, etc., of metals, etc., from temperature, 167  
     " expansion, coefficients of, 167  
 Lines of the arch, 283  
 Lintel, 247  
 Linville bridge, 334  
 Liverpool and Manchester road, rail of, 431  
 Load, effect on roads, 445  
 Location of a bridge, 280  
     " of canals, 469  
     " of common roads, 405  
 Locality, effect on stone, 15  
 Lock and dam navigation, 531  
     " gates, canal, 487  
     " of a canal, 472  
     " tide or guard, of a canal, 490  
 Locks, canal, 482  
     " for basins, 511  
     " left of canal, 479  
 Locomotion on canals, 493  
 Locust, 88  
 London bridge, new, 301  
 Longitudinal dikes on rivers, 499  
 Long's truss, 315  
 Losses of water in a canal, 472  
 Louisville bridge, 339  
 Lowlands, dikes to protect, 542  
 Lumachella marble, 10
- MCADAM**, pavement of, 424  
 McCallum's truss, 320  
 McDonald, swing bridge by, 385  
 Macadamized roads, 424  
 Machines for mortar, 51  
 Machines, power-drilling, 442  
 Macneill, force of traction, 407  
 Magnesian limestone, 10  
 Main chains of suspension bridges, 363  
 Malaxator, the, 54  
 Mallet, caoutchouc varnish, 102  
     " on preserving iron, 94, 95  
     " report on iron, 90, 91  
     " varnish for zincked iron, 102  
 Mallet's processes for preserving iron, 97  
 Manipulations of mortar, 51  
 Manlius hydraulic limestone, 20  
 Manner of reducing hydraulic cement, 40  
 Map and memoir for a road, 405  
 Marble, 9  
 Marbles, 10
- Marshy soils, 49  
     " soils, foundations in, 195  
 Masonry, 172  
     " component parts of structures, 238  
     " construction of, 236  
     " dams, 478  
     " effect of temperature on, 261  
     " of arches, 253  
     " of tunnels, 441  
     " repairs of, 260  
 Mastic for roads, 428  
 Mastics, 74  
 Materials, building, 3  
     " for frames, 263  
     " for roads, 428  
     " strength of, 104  
 Meager limes, 18  
 Means for centring the arch, 290  
 Measure of crushing force, 108  
 Measures against inundations, 498  
     " for increasing strength of retaining-walls, 244  
 Menai suspension bridge, 368  
 Metal fastenings in masonry, 180  
 Metals, 89  
     " strength of, 167  
 Methods of powdering calcined lime stone, 37  
     " of preserving surface of stone, 103  
     " of seasoning timber, 81  
     " of strengthening masonry, 179  
 Mica slate, 6  
 Mill, Ft. Warren mortar, 52  
     " of Cointet, 54  
 Millstone, 7  
 Minard and Desormes, strain of timber, 122  
 Mineral, agaric, 79  
     " tar, 74  
 Model tube for bridge, 349  
 Modillions, 302  
 Modulus of lateral elasticity, 561  
     " of longitudinal elasticity, 561  
 Mole at Algiers, 538  
 Moment of rupture, 554  
 Monongahela wire bridge, 373  
 Mont Cenis railroad, 439  
     " tunnel, 442  
 Montpellier, roof of capitol st., 400, 402  
 Morin, cubical stone pavements, 423  
 Morris, on roads, 409  
 Mortar, 46

- Mortar, adherence of, 73**  
 " bed in brickwork, 184  
 " how injured, 51  
 " hydraulic, 46, 48  
 " manipulations of, 51  
 " mill, 52  
**Mortars exposed to weather, 50**  
 " setting and durability of, 57  
 " strength of, 115  
 " theory of, 58  
**Mortise joints, 270**  
**Movable bridges, 380**  
  
**NANTES, bridge at, 231**  
**Narrow gauge for railroad, 435**  
**Natural features of rivers, 494**  
 " puzzolanas in U. S., 43  
**Navigable canals, 467**  
**Navigation, slack-water, 531**  
**Neuilly bridge, 295**  
**Neutral line or axis, 106**  
**Newell stone in masonry, 176**  
**Niagara suspension bridge, 374**  
**Nomenclature, bridge, 314**  
**Norton, deflection of wooden beams**  
 128  
  
**OAK, 87**  
**Object in framing, 263**  
**Oblique arches, 285**  
**Obstructions in rivers, 530**  
**Offsets, 236**  
**Omaha bridge, 229**  
**Open-built beams, 271**  
 " side drains, 417  
**Operations in tunnelling, 440**  
**Oriental granite, 6**  
**Owen, effects of frost on stone, 15**  
  
**PAGE's lime-kilns, 34**  
**Paint, black, 101**  
 " gray or stone color, 101  
 " lead color, 101  
 " white (for exposed wood), 101  
**Paints, 100**  
**Palladiumizing iron, 97**  
**Pallu, church built by, 188**  
**Parallel rail, 432**  
**Parapet of wooden bridge, 323**  
**Paris, concrete walls in, 185**  
 " sewers, 188  
**Park, Central, of N. Y., roads, 425**  
**Parker's cement, 12**  
**Pauley, artificial hydraulic lime, 41**  
 " hydraulic cements, 50  
 " on adherence of mortars, 73,  
 74  
 " strength of stone, 111  
  
**Patapoco, bridge over the, 307**  
**Pavement, best, 421**  
 " of cubical stone, 423  
 " rubble, 421  
**Pavements, 419, 420**  
 " asphaltic, 421  
 " in England, 421  
 " in France, 422  
 " stone for, 420  
 " wooden, 421  
**Paving-stones, 420**  
**Pebbles, Boulogne, 20**  
**Permanent strain in stone, 113**  
 " way, stability of, 443  
 " ways, experiments on, 441  
**Perpetual lime-kilns, 28, 31**  
**Petot, on lime-kilns, 29, 30**  
 " on mortars, 59  
 " table of limes, 19  
**Physical characters of hydraulic lime-**  
**stones, 23**  
**Pieces, bridge or suspension, 274**  
**Piera, 248**  
 " abutment, 205  
 " for bridges, 205  
 " for wooden bridges, 310  
 " of iron bridges, 325  
 " of suspension bridges, 363  
**Pig-metal, colors, 93**  
**Pile engines, 197**  
**Piles, diaphragm, 197**  
 " foundations on, 196  
 " of iron, 203  
 " pneumatic, 220  
 " screw, 196  
 " sheeting, 208  
**Pillars, comparative strength of, 124**  
 " iron, 134  
 " pressure on, 134  
 " properties of, 134  
 " resistance of wood, 123  
 " transverse strain on, 125  
**Pine, 88**  
**Pinning up in masonry, 177**  
**Pittsburgh, bridge at, 344**  
**Plank-roads, 430**  
**Plaster-of-Paris, 13**  
**Plate-band, the, 247**  
**Platform, a, 193**  
**Plymouth breakwater, 587**  
 " bridge near, 309  
**Pneumatic caissons, 229**  
 " piles, 220  
 " processes for foundations,  
 220  
**Pointing, 259**  
**Polencean, tubular ribs, 329**  
**Polish for Berlin castings, 103**

- Poncelet, embankment walls, 240  
   " movable bridge, 382  
 Pont d'Austerlitz, 326  
   " des Arts, 326  
   " du Carrousel, 326  
 Porphyry, 5  
 Portland cement, 20  
   " cement, strength, etc., of,  
     117  
 Port Said lighthouse, 187  
 Post's combination bridge, 342  
   " iron bridge, 340  
   " truss, 339  
 Potomac aqueduct, 298, 308, 212  
 Power-drilling machines, 442  
 Pratt's truss, 320  
 Precautions against arches settling,  
   258  
   " water, 192  
   " yielding of founda-  
     tions, 204  
 Preservation of suspension bridges,  
   306  
   " timber, 83, 84  
 Preservatives of iron, 95  
 Preserving iron, 94  
   " surface of stone, 103  
 Prism of draught, 474  
   " of lift, 474  
   " what is a, 545  
 Prize for canal locomotion, 493  
 Problems for strains on bars, 546  
   " on beams, 564  
   " on curved beams, 595  
   " on lattice girder, 589  
   " on roof trusses, 583  
 Processes for making steel, 98  
   " for preserving iron, 97  
 Proofs of suspension bridges, 366  
 Proportions for Coignet betons, 189  
   " for concrete, 68  
 Props, 272  
 Protecting banks of rivers, 496  
   " sides of a road, 411  
 Protection of masonry, 260  
 Providence swing bridge, 385  
 Puddling, 10  
 Puddling, 208  
 Purlins, 393  
 Puzzolana, 43  
  
 QUALITY of brick, 77  
 Quarries of marble, 11  
 Quarry-bed, 183  
 Quay walls, 542  
 Quays of wet-docks, 541  
 Queen-posts, 274  
 Quicklime, 9  
  
 RAFTERS, 264, 393  
 Rafts in rivers, 531  
 Rail, fish-bellied, 431  
   " in U. S., 432  
   " joints, 464  
   " of Great Western road, etc., 432  
   " parallel, 432  
   " resistance to lateral forces, 442  
 Railroad ballast, 434  
   " crossings, 464  
   " curves, 436  
   " gradients, 438, 439  
   " sidings, 436  
   " street crossings, 438  
   " switches, 437  
   " tunnels, 439  
   " turn-plates, 438  
   " velocity on, 438  
 Railroads, effect of speed on, 443  
   " gauge of, 435  
   " grade of, 439  
 Rail, straight, 432  
 Rails, 430  
   " angle of deflection, 437  
   " durability of, 433  
   " rolled, 433  
   " steel, 433  
   " steel, breakage of, 464  
   " steel-headed, 466  
   " steel, results, 464  
   " steel, wear of, 464  
   " supports of, 433  
   " wear of, 433  
   " wrought iron, 433  
 Railways, 430  
   " temporary, 434  
 Railway sleepers, 462  
   " spikes, Funk's experiments,  
     451  
   " spikes, Von Weber's experi-  
     ments, 453  
 Raising large stones, 182  
 Range, 248  
 Ransome's artificial stone, 63  
 Ratio of tensile to compressive forces  
   in cast iron, 132  
 Raucourt de Charleville, protection of  
   masonry, 260  
 Reconnaissance for a road, 403  
 Red sandstone, 8  
 Reducing hydraulic cement, 40  
 Regimen of a river, 494  
 Relation between strains and forces,  
   563  
 Relieving-arches, 245  
 Rendel, bridge built by, 309  
 Rennie, effect of temperature on  
   bridges, 331

- Rennie, experiments on iron, 168  
 " strength of copper, 166  
 " strength of tin and lead, 167  
 " table of strength of stone, 110  
 " tensile strength of cast iron, 131  
 Renwick's process for protecting timber, 86  
 Repairs of masonry, 260  
 " of roads, 428  
 Repose, angle of, 407  
 Requisites of strength in masonry, 175  
 Recherches on strength of materials, 164  
 Resistance of cast iron to compression, 131  
 " of cast iron to extension, 131  
 " of copper to strain, 166  
 " of cylindrical columns, 132  
 " of iron to torsion, 162  
 " of iron-wire to impact, 161  
 " solids of equal, 555  
 " of square wood pillars, 123  
 " of timber to detrusion, 130  
 " of timber to strain, 122, 125  
 " of timber to transverse strain, 125  
 " of wrought iron to compressive strain, 154  
 " of wrought iron to tensile strain, 147  
 Reservoirs, canal, 474, 476  
 Results of steel rails, 464  
 Retaining-walls, 239  
 Revêtements, 245  
 Rhine, wing-dams on, 493  
 Ribs for light arches, 290  
 " in a bridge-frame, 322  
 " of iron bridges, 325  
 " tubular, 325, 329  
 Rideau canal, 492  
 Riebell, strength of frames, 374  
 River bars, 502  
 " improvements, 495  
 Rivers, 494  
 " protecting banks of, 496  
 Road covering, broken stone, 423, 425  
 " coverings, 419  
 " drainage, 413, 416  
 " effect of speed on, 443  
 Roadsteads, 536  
 Roads, 403  
 " benches of, 413  
 Roads, cleaning of, 429  
 " country, 425  
 " cross dimensions of, 429  
 " earthwork of, 411  
 " embankments of, 409, 414  
 " excavations for, 411  
 " French views on, 426  
 " gravel, 425  
 " location of common, 405  
 " macadamized, 424  
 " map and memoir of a, 405  
 " mastic for, 428  
 " materials for, 428  
 " park, 426  
 " plank, 430  
 " repairs of, 428  
 " Roman, 421  
 " setting lines of, 410  
 " side channels of, 417  
 " side slope of, 411  
 " slips on, 412  
 " stone for, 15  
 " summer, 429  
 " surface water of, 418  
 " Telford's plan, 424  
 Roadway of suspension bridges, 364  
 " of wooden bridge, 323  
 Roadways, asphaltic, 427  
 Rock, 4  
 Rock foundations, 191  
 Roebling, East River bridge, 380  
 " experiments on wire, 158  
 " Monongahela bridge, 373  
 Rogers, analyses of magnesian lime stones, 22  
 Rolled rails, 433  
 Roller for compressing roads, 427  
 Rolling bridges, 380, 391  
 " mills, roof of, 400  
 Roman cement, 12  
 " strength of, 118  
 " roads, 421  
 Rome (N. Y.) bridge, 344  
 Rondelet, on adherence of mortars, 71  
 " on walls, 238  
 " specific gravity and strength of stone, 113  
 Roofing slate, 8  
 Roof of capitol at Montpelier, 400, 402  
 " of University of Mich., 401, 402  
 " truss, depot, 399  
 " problems on, 553  
 " trusses, 393  
 " iron, 396  
 Roofs, 393  
 " and domes, 400  
 " snow and wind on, 394

- Ropes for inclined planes, 439**  
 " iron, steel, and hemp, comparative strength of, 156  
**Rot, wet and dry, 83**  
**Rubble pavement, 431**  
 " stone masonry, 183  
**Rules to determine strength of cast-iron beams, 143**  
**Rupture by compression, 107**  
 " by tensile force, 107  
 " moment of, 554  
 " of arches, 257  
  
**SALT in mortar, 47**  
**Sand, 47**  
 " Fontainebleau, 187  
 " for centring arches, 290  
 " for foundations, 203  
 " for pavements, 420  
 " foundations, 192  
**Sandstone, 7**  
**Savannah, bridge over the, 228**  
**Sawyers in rivers, 530**  
**Scaffolding, 185**  
**Scarf-joint, 208**  
**Schonectady bridge, 344**  
**Schuykill bridge, 317**  
**Scorff, bridge over the, 230**  
**Screw piles, 196**  
**Seacoast improvements, 534**  
 " walls, 543  
 " water for mortar, 189  
**Seasoning timber, 81**  
**Section, dangerous, 555**  
 " of retaining-walls, 243  
**Seekonk River bridge, 201**  
**Septaria, 20**  
**Setting lines of a road, 410**  
 " of mortars, 57  
**Settling of arches, precautions against, 253**  
 " of embankments, 414  
**Severn, bridge over, 326**  
**Sewers of beton agglomeré, 188**  
**Seyssel bituminous sandstone, 74**  
**Shafts for road drainage, 413**  
 " working, 440  
**Shearing strain, 560**  
 " " resistance of iron to, 161  
**Sheeting piles, 208**  
**Ship-worms, 86**  
**Shoe-plates, 290**  
**Shores, 272**  
**Side channels of roads, 417**  
 " cuttings, 416  
 " drains, 417  
 " slope of a road, 411  
  
**Sidewalks, 423**  
 " asphaltic, 427  
**Sidings of railroads, 436**  
**Sienite, 5**  
**Silex, 4**  
**Silicious sands, 47**  
 " stones, 4  
**Single lattice girder, 589**  
**Slack-water navigation, 531**  
**Slaked lime, 9**  
**Slaking lime, 37**  
**Slate, graywacke, 8**  
 " hornblende, 8  
 " mica, 6  
 " roofing, 8  
 " talcose, 7  
**Sleeper for railroad, 434**  
**Sleepers, force to draw spikes out, 456**  
 " how affected, 448  
 " railway, 462  
**Slips on a road, 412**  
**Smith (W. S.) on pneumatic caissons, 229**  
**Snags, 530**  
**Snow, weight of, 394**  
**Soapstone, 7**  
**Soffit, 248**  
**Soils, compressible, foundations in, 192**  
 " for foundations, 190  
 " wet and marshy, 419  
**Solders, 99**  
**Solid-built beams, 265**  
 " contents of a road, 409  
**Solids, extension and contraction of, 106**  
 " of equal resistance, 525  
**Souillac, bridge of, 308**  
**Southwark bridge, 326**  
**Specific gravity of cast iron, 92**  
**Speed of trains, effect of, 443**  
**Spikes, force to draw out of sleepers, 456**  
 " iron, adhesion to timber, 170  
 " railway, experiments on, 451, 453  
**Spoil-bank, 416**  
**Springs, causing road slips, 413**  
**Spruce, 89**  
**Stability of a permanent way, 443**  
**Staines bridge, 326**  
 " iron bridge at, 331, 332  
**Statuary marble, 10**  
**Steatite, 7**  
**Steam for canals, 493**  
 " pile-driver, 198  
**Steel, 98**  
**Steel-headed rails, 466**



- Steel rails, 433  
   " breakage of, 464  
   " results, 464  
   " traction on, 465  
   " wear of, 464  
 Steel, strength of, 163  
 Steep gradients, railroad, 439  
 Stephenson, tubular bridges, 348  
 Stirrups, 266  
 Stone, 4  
 Stone bridges, 279  
   " of Europe, 308  
   " for pavements, 420  
   " jetty, 539  
   " preserving surface of, 103  
   " tramways, 420  
 Stones, arch, 243  
   " broken, road covering, 423, 425  
   " cut, 174  
   " durability of, 13  
   " expansion of, 114, 115  
   " paving, 420  
   " strength of, 109  
 Stoney, tables of strength of rope, 150  
 Stony ground foundations, 191  
 Straight rail, 432  
 Strain, breaking, of wrought iron, 152  
 Strain on pillars, 135  
   " on unit of area, 554  
   " permanent, on stone, 118  
   " resistance of timber to, 122, 125  
   " resistance of wrought iron to, 147  
   " shearing, 560  
   " shearing, resistance of iron to, 161  
   " workings of wrought iron, 152  
 Strains and forces, relations between, 563  
   " classification of, 545  
   " cross, frames for, 264  
 Straining beam, 272  
 Street crossings of railroads, 438  
 Strength, etc., of Portland cement, 117  
   " comparative, of iron, steel, and hemp rope, 157  
   " in masonry, requisites of, 175  
   " of beton, 118  
   " of boiler iron, 148  
   " of cast iron, 91, 181  
   " of cast iron beams, rules to determine, 143  
   " of concrete, 118  
   " of copper, 166  
   " of frames, 274  
   " of materials, 104  
   " of mortars, 115  
   " of other metals, 167  
   " of Roman cement, 118  
   " of steel, 163  
   " of stone, 109  
   " of timber, 119  
   " of wrought iron, 98, 147  
   " of wrought iron, effect of temperature on, 158  
 Strengthening brick-work, 184  
 Stretchers, in masonry, 177  
 Striking-plates, 290  
 St. Lawrence canals, 492  
 St. Louis bridge, 231  
 St. Louis and Illinois bridge, 344  
 Structures, component parts of, 288  
   " foundations, 190  
   " in water, 208  
 Struts, 264  
   " inclined, 272  
 Stucco, 260  
 Style of architecture for bridges, 294  
 Summer roads, 429  
 Summit level, 467, 471  
 Sunderland bridge, 326  
 Superstructure of a bridge, 303  
 Support, framing for intermediate, 273  
 Supports of rails, 433  
   " vertical, 289  
 Surfaces of the arch, 282  
 Surface water of a road, 413  
 Survey for a bridge, 280  
 Surveys, 405  
 Suspending chains of bridges, 364  
 Suspension bridge, East River, 379  
   " Fribourg, 370  
   " Hungerford, 371  
   " Menai, 368  
   " Monongahela, 373  
   " Niagara, 374  
   " over the Tweed, 368  
 Suspension bridges, 357  
   " abutments, 363  
   " cables of, 360  
   " chains of, 360  
   " durability of, 367  
   " main chains of, 363  
   " piers of, 362  
   " preservation of, 366  
   " proofs of, 366  
   " roadway, 364  
   " vibrations of, 363  
 Suspension pieces, 274  
 Sustaining-walls, 239, 415

- Sweden, experiments on steel, 163  
 Swing-bridge, Providence, 335  
 Swinging-bridges, 330  
 Switches, railroad, 437  
 System of Buck, 286  
 Szegedin, bridge at, 227
- TABLE of average values of moduli, 618  
 " of coefficients of linear expansion, 168  
 " of experiments on cast-iron bar impinged upon, 144, 145  
 " of hydraulic cements, 20  
 " of ratio of tensile to compressive forces in cast iron, 132  
 " of results of experiments on bars of hot-blast iron, 139, 140  
 " of strength of boiler-iron, 148  
 " of strength of square and round bars of wrought iron, 148  
 " of strength of stone, 110, 111, 112  
 " of wear of stone, 16, 17  
 " comparative strength of iron, steel, and hemp-rope, 186
- Talcose slate, 7  
 Tall's bracket scaffolding, 185  
 Tar, mineral, 74  
 Tedford, Menai bridge, 368  
 Telford pavement, 424  
 Temperature, effect on bridges, 331  
 " effect on copper, 167  
 " effect on masonry, 261  
 " effect on stone, 114  
 " effect on strength of wrought iron, 158  
 " effect to expand metals, etc., 167  
 " effects on iron, 137
- Temporary dams, canal, 490  
 " railways, 434
- Tensile strain, resistance of timber to, 122  
 " resistance of wrought-iron to, 147
- Tenon joints, 270  
 Terms in bridge nomenclature, 314  
 Testing cast iron, 91  
 Tests of hydraulic limestones, 23  
 " of steel-rails, 465  
 Tewksbury bridge, 326  
 Thames tunnel, 184  
 Theiss, bridge over the, 227  
 Theory of mortars, 58  
 " of tides, 534  
 " of waves, 535
- Thermo-tension, effects on wrought-iron, 161  
 Thickness of walls, 238  
 Thomas viaduct, the, 307  
 Through, a, in masonry, 178  
 Tidal water, coffer-dams in, 210  
 Tide-lock of a canal, 490  
 Tides, theory of, 534  
 Tie-joints, 271  
 Ties, 264  
 " for detached frames, 395
- Tiles, 79  
 Timber, adhesion of iron-spikes to, 176  
 " defects of, 82  
 " destroyers, 86  
 " durability of, 86  
 " most durable, 83  
 " neutral axis of, 107  
 " preservation of, 83, 84  
 " resistance to detrusion, 130  
 " resistance to strain, 122, 125  
 " seasoning, 81  
 " strength of, 119
- Time, effects of, in elongation of wrought iron, 155  
 " effects of, on deflections, 130
- Tin, 99  
 " strength of, 167
- Torsion, resistance of iron to, 162  
 Totten, on brick masonry, 184  
 " on river wing-dams, 499  
 " strength of mortars, 116
- Town's truss, 316  
 Tow-path, 468  
 Traction, force of, 407  
 " on steel rails, 465
- Tramways, iron, 430  
 " stone, 420
- Transverse strain on wrought iron, 154  
 " strain, resistance of timber to, 125  
 " strength of cold-blast iron, 136
- Trapezoidal truss, Whipple's 332  
 Trass, 43  
 Tredgold, resistance of timber to detrusion, 130  
 Tree, trunk of, 80  
 Trees, felling, 80  
 " girdling and barking, 80  
 " of United States, 86
- Treussart, beton foundations of coffer-dams, 215  
 " on hydraulic mortar, 49  
 " on puzzolanas, 44
- Trial-lines, 405

- Triumphal arch, 369**  
**Trunk of a tree, 80**  
**Truss, arched, 337**  
   " Bollman's, 337  
   " bridges, vertical shearing, 595  
   " Burr's, 318  
   " depot roof, 399  
   " Fink, 338  
   " Howe's, 317  
   " lattice, 316  
   " Linville, 334  
   " Long's, 315  
   " McCallum's, 320  
   " Post's, 339  
   " Pratt's, 320  
   " Town's, 316  
   " weights borne by, 275  
   " Whipple's trapezoidal, 333  
**Trusses for wooden bridges, 315**  
   " iron roof, 396  
   " roof, 393  
**Tube, model, for bridge, 349**  
**Tubes, iron, breaking weight of, 354**  
**Tubular bridge, Britannia, 350**  
   " bridges, 347  
   " iron-ribs, 328, 329  
**Tunnel, Hoosac, 442**  
   " Mont Cenis, 443  
**Tunnelling, operations in, 440**  
**Tunnels, 439**  
   " drainage of, 442  
   " masonry of, 441  
   " water in, 442  
**Turnbull, bridge built by, 308**  
**Turning-bridges, 380, 384**  
**Turn-plates, 438**  
**Tweed, suspension bridge over, 368**  
**ULSTER Co. hydraulic limestone, 21**  
**Under-pinning in masonry, 177**  
**United States, canals, 487**  
   " lime-burning in, 31  
   " rail used in, 432  
**Unit of area, strain on, 554**  
**University of Michigan, roof of, 401, 402**  
**VARIETIES of iron, 90, 92**  
   " oak, 87  
   " paints, 101  
   " pine, 88  
   " steel, 98  
**Varnish, copal, 101**  
   " for zincked iron, 103  
   " Japan, 101  
**Varnishes, 100**  
**Velocity on a railroad, 438**  
**Verd antique, 11**  
**Vertical supports, 239**  
**Vesniel, Gothic church, 187**  
**Viaduct, 279**  
   " the Carrollton, 308  
   " the Thomas, 307  
**Vibrations of suspension bridges, 365**  
**Vicat, artificial hydraulic lime, 41**  
   " cement limestones, 18  
   " effect of temperature on bridges, 331  
   " fuel for lime-burning, 27  
   " hydraulic magnesian limestones, 21  
   " magnesian limestone of France, 22  
   " on dolomites, 11  
   " on elongation of wrought iron, 155  
   " on hydraulic mortar, 49  
   " strength of mortar, 50  
   " strength of mortars, 116  
   " strength of stone, 113  
**Victoria bridge, 212, 354**  
**Volumes of the arch, 288**  
**Von Weber, experiments on rails, 442**  
**Von Weber on stability of permanent ways, 443, 446**  
**Von Weber's experiments, deductions from, 461**  
**Von Weber's experiments on railway spikes, 453**  
**Voussoirs, 248, 283**  
**WADE, crushing-weights of cast iron, 160**  
   " tenacity of iron, 138  
**Walker, table of wear of stone, 16**  
**Wall for an embankment, 240**  
**Walls, concrete, 185**  
   " of enclosure, 238  
   " quay, 542  
   " retaining or sustaining, 239  
   " sea, 548  
   " sustaining, 415  
**Waste-weir, 479**  
   " of a canal, 490  
**Water decreases linear expansion, 169**  
   " effect on stone, 15  
   " flame lime kilns, 34  
   " in tunnels, 442  
   " precautions against, 192  
**Waterloo bridge, 292**  
**Water, structures in, 208**  
   " supply of a canal, 477  
   " wings of a bridge, 306  
**Water-way, 467**

- Water-way**, enlargement of, 306  
 " in bridge-building, 280  
**Waves**, 535  
**Wear** of rails, 433  
 " of steel rails, 464  
 " of stone, 14  
 " Coriolis' table, 17  
 " Walker's table, 16  
**Weather**, mortars exposed to, 50  
**Wedges**, folding, 266  
**Weight** of snow, 394  
**Welland canal**, 492  
**Wernwag's Schuylkill bridge**, 317  
**Wet-docks**, 541  
**Whipple's trapezoidal truss**, 333  
 " truss, modifications of, 334  
**Whirlpools**, 534  
**Woelker**, experiments relative to suspension bridges, 367  
**Width** of roads, 429  
**Williamsport canal bridge**, 490  
**Wind**, force of the, 394  
**Wing-dams**, 497  
**Wing-walls** of bridges, 299  
**Wire**, iron, resistance to impact, 161  
**Wood**, 79  
**Wooden arches**, 277, 321  
 " beams, deflection of, 128  
 " bridges, 310  
**Wooden bridges**, celebrated, 324  
 " jetties, 539  
 " pavements, 421  
**Wood pillars**, resistance of, 123  
**Working strain** of stone, 111-114  
 " strain of wrought iron, 152  
**Works**, accessory, of a canal, 438  
**Wright, W. H.**, on mortar mill, 53  
**Wrought iron**, 92  
 " bridges, 347  
 " conclusions of Kirkaldy on strength of, 149  
 " elongation of, 155  
 " rail, 431  
 " rails, 433  
 " resistance to compression, 154  
 " resistance to transverse strain, 154  
 " strength of, 147  
 " temperature, effects on, 158  
 " thermo-tension of, 161  
**YIELDING** of arches, 257  
**ZINC**, 99  
**Zincked iron**, varnish for, 103  
**Zincking iron**, 95  
**Zoofagous paint**, 102, 103













2 dia  
J.H.

