

6.77

6.77 A viscous, incompressible fluid flows between the two infinite, vertical, parallel plates of Fig. P6.77. Determine, by use of the Navier-Stokes equations, an expression for the pressure gradient in the direction of flow. Express your answer in terms of the mean velocity. Assume that the flow is laminar, steady, and uniform.

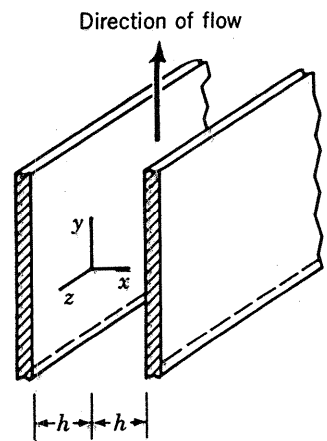

FIGURE P6.77

With the coordinate system shown $u=0, w=0$ and from the continuity equation $\frac{\partial v}{\partial y}=0$. Thus, from the y -component of the Navier-Stokes equations (Eq. 6.127b), with $g_y = -g$,

$$0 = -\frac{\partial P}{\partial y} - \rho g + \mu \frac{d^2 v}{dx^2} \quad (1)$$

Since the pressure is not a function of x , Eq. (1) can be written as

$$\frac{d^2 v}{dx^2} = \frac{P}{\mu}$$

(where $P = \frac{\partial P}{\partial y} + \rho g$) and integrated to obtain

$$\frac{dv}{dx} = \frac{P}{\mu} x + C_1 \quad (2)$$

From symmetry $\frac{dv}{dx} = 0$ at $x=0$ so that $C_1 = 0$. Integration of Eq. (2) yields

$$v = \frac{P}{\mu} \frac{x^2}{2} + C_2$$

Since at $x = \pm h$, $v = 0$ it follows that $C_2 = -\frac{P}{2\mu} (h^2)$ and therefore

$$v = \frac{P}{2\mu} (x^2 - h^2)$$

The flowrate per unit width in the z -direction can be expressed as

$$q = \int_{-h}^h v dx = \int_{-h}^h \frac{P}{2\mu} (x^2 - h^2) dx = -\frac{2}{3} \frac{P h^3}{\mu}$$

Thus, with V (mean velocity) given by the equation

$$V = \frac{q}{2h} = -\frac{1}{3} \frac{P h^2}{\mu}$$

it follows that

$$\frac{\partial P}{\partial y} = -\frac{3\mu V}{h^2} - \rho g$$