

# PMM-PIV

(Phase-averaged 3D Unsteady flow around a surface ship)

PMM Test:

- (a) Static drift test
- (b) Pure sway test
- (c) **Pure yaw test**
- (d) Yaw and drift test

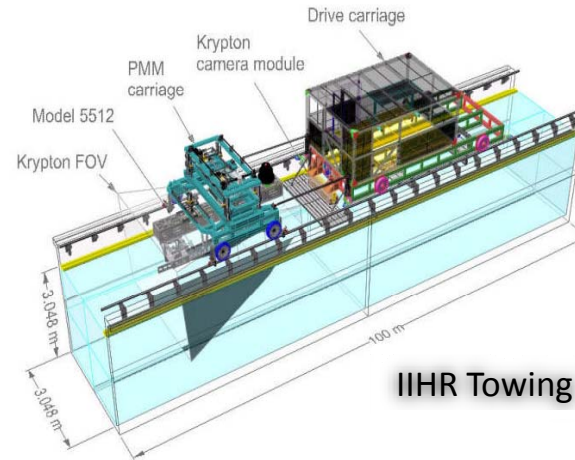
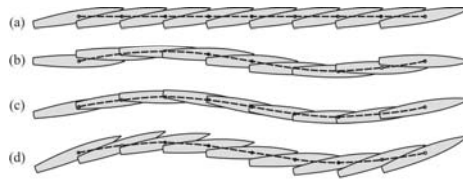

IIHR Towing Tank Facility

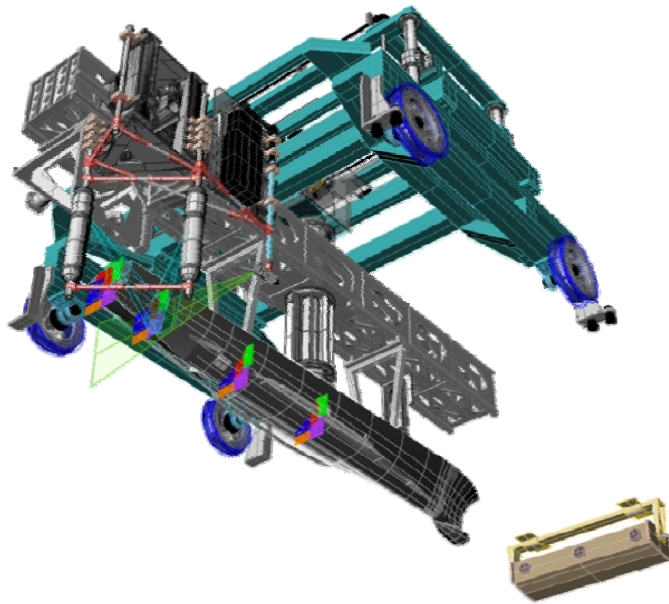

PMM-PIV arrangement

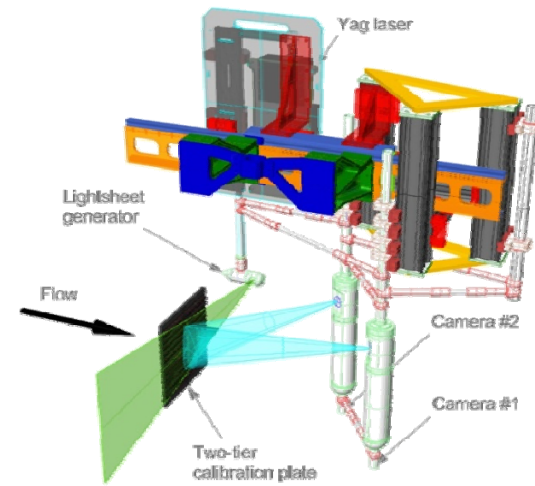

3D Stereo PIV System

# Comparisons with CFD<sup>†</sup>

(Turbulent flow structure)

EFD

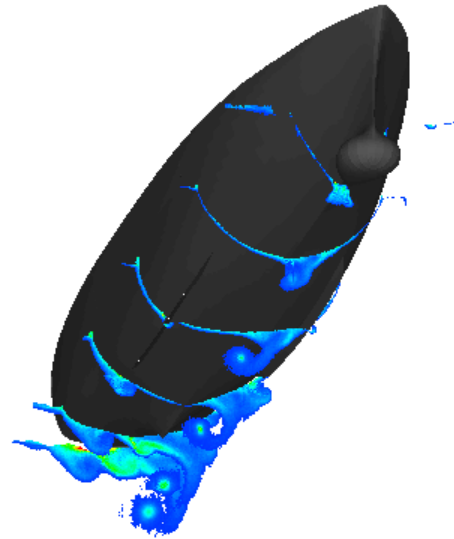

CFD

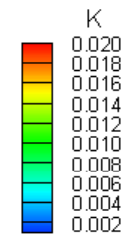

<sup>†</sup> N. Sakamoto, P. Carrica, J. Shao , CFDSHIP-IOWA (2006)

# Comparisons with CFD<sup>†</sup>

(Vortical flow structure)

RANS

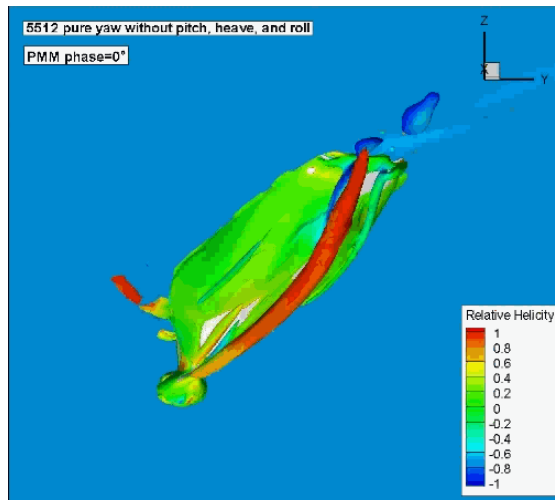

DES

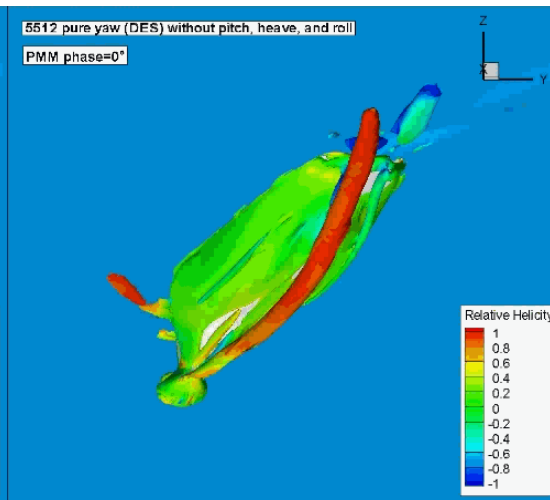

PIV

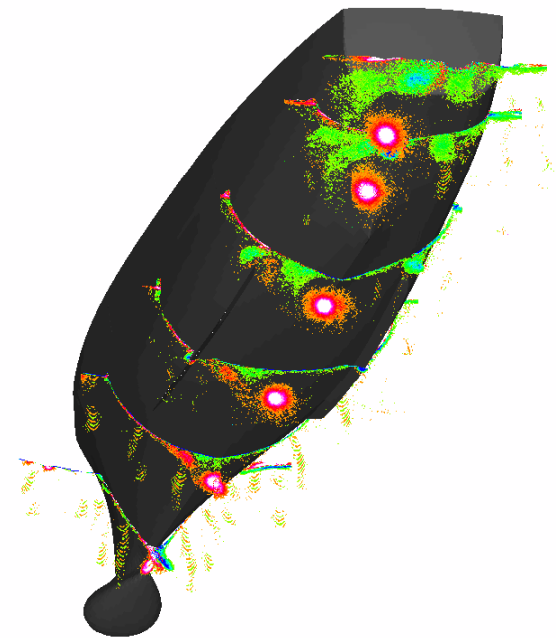

<sup>†</sup> N. Sakamoto, P. Carrica, J. Shao , CFDSHIP-IOWA (2006)