

Eliminating the "Mole"



The CEO of a firm in a highly competitive industry believes that one of her key employees is providing confidential information to the competition....

The chief executive officer of a firm in a highly competitive industry believes that one of her key employees is providing confidential information to the competition.

She is 90% certain that this informer is the **vice-president of finance**, whose contacts have been extremely valuable in obtaining financing for the company.

- If she decides to fire this VP and he *is* the informer, she estimates that the company will gain **\$500,000**.
- If she decides to fire this VP but he *is not* the informer, the company will lose his expertise and still have an informer within the staff—the CEO estimates that this outcome would cost her company about **\$2.5 million!**
- If she decides not to fire this VP, she estimates that the firm will lose **\$1.5 million** whether or not he is actually the informer (since in either case the informer is still with the company).

Before deciding whether to fire the VP for finance, the CEO could order *lie detector tests*.

To avoid possible lawsuits, the lie detector tests would have to be administered to all company employees, at a total cost of \$150,000.

Another problem she must consider is that the available lie detector tests are not perfectly reliable:

- the probability of a *false positive* is 15%
- the probability of a *false negative* is 5%.

That is, *since here “positive” means detecting a lie,*

- if a person is not lying, the test will incorrectly suggest that the person is lying 15% of the time.
- if a person is lying, the test will incorrectly suggest that the person is telling the truth 5% of the time.

In order to minimize the expected total cost of managing this difficult situation, what strategy should the CEO adopt?

Also, determine the *maximum* amount of money that the CEO should be willing to pay to administer lie detector tests.

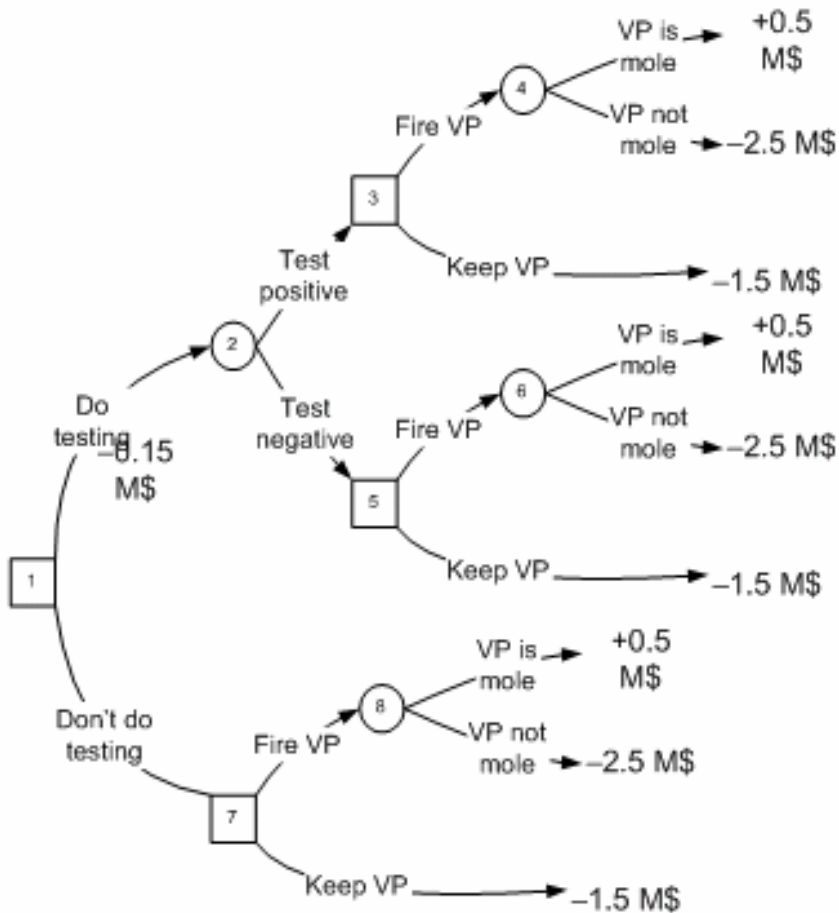

The **posterior probabilities** need to be computed using **Bayes' Rule**:

“States of nature”:

- VP is mole
- VP not mole

“Observations of experiment”:

- positive (he is lying)
- negative (he is truthful)

For example:

$$P\{VP \text{ is Mole} \mid +\} = \frac{P\{VP \text{ is Mole} \& +\}P\{VP \text{ is Mole}\}}{P\{+\}}$$

Computation of posterior probabilities

$$\begin{aligned}P\{VP \text{ is Mole} | +\} &= \frac{P\{+ | VP \text{ is Mole}\}P\{VP \text{ is Mole}\}}{P\{+\}} \\ &= \frac{(0.95)(0.9)}{0.87} \\ &= \frac{0.855}{0.87} \\ &= 0.9828\end{aligned}$$

where

$$\begin{aligned}P\{+\} &= P\{+ | VP \text{ is Mole}\}P\{VP \text{ is Mole}\} + P\{+ | VP \text{ not Mole}\}P\{VP \text{ not Mole}\} \\ &= (0.95)(0.9) + (0.15)(0.1) \\ &= 0.87\end{aligned}$$

Computation of posterior probabilities

$$\begin{aligned}P\{VP \text{ is Mole} | -\} &= \frac{P\{- | VP \text{ is Mole}\}P\{VP \text{ is Mole}\}}{P\{-\}} \\ &= \frac{(0.05)(0.9)}{0.13} \\ &= \frac{0.045}{0.13} \\ &= 0.3462\end{aligned}$$

We can now insert these probabilities in the decision tree and “fold it back”...

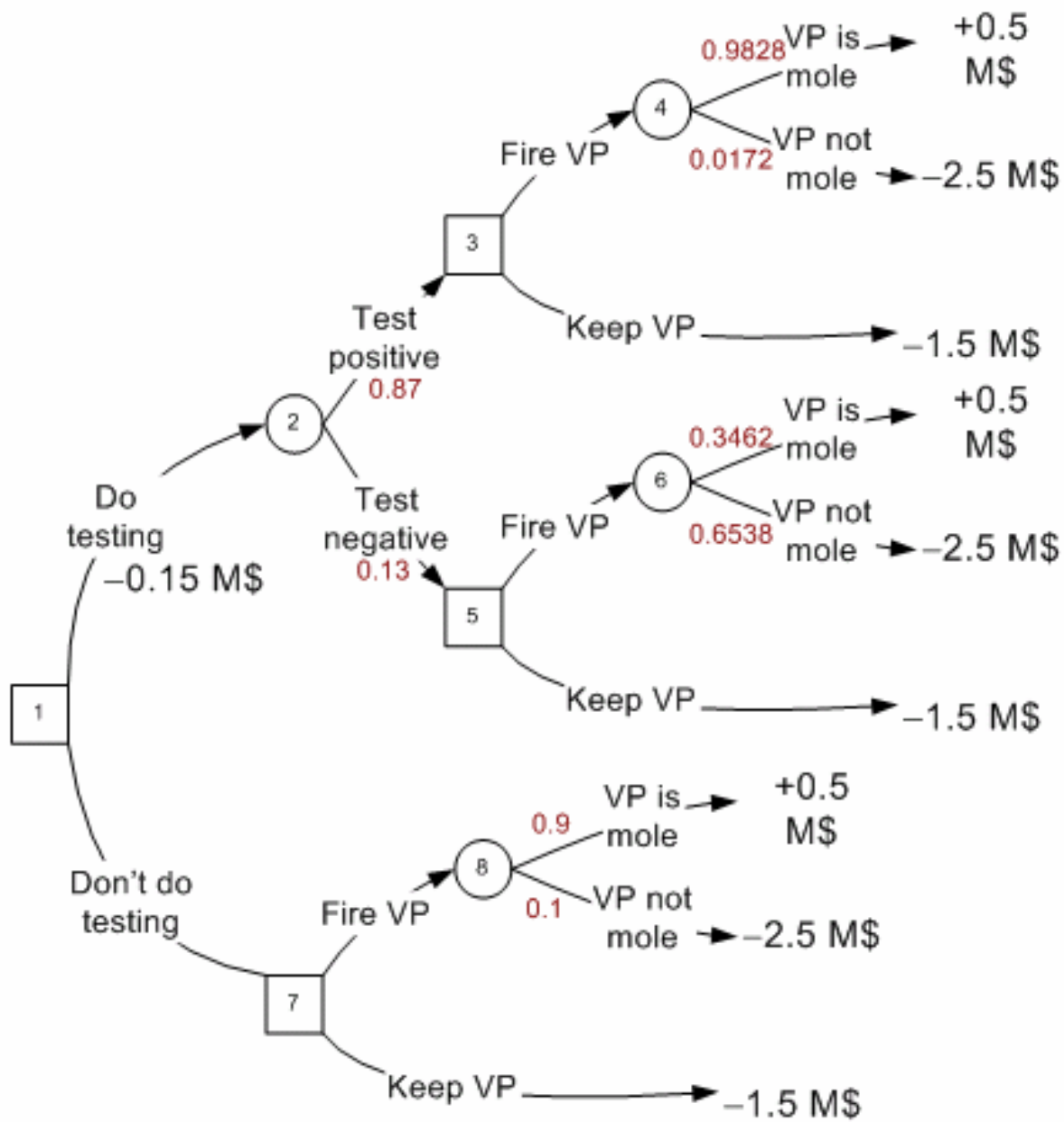

Treeplan
Excel add-in

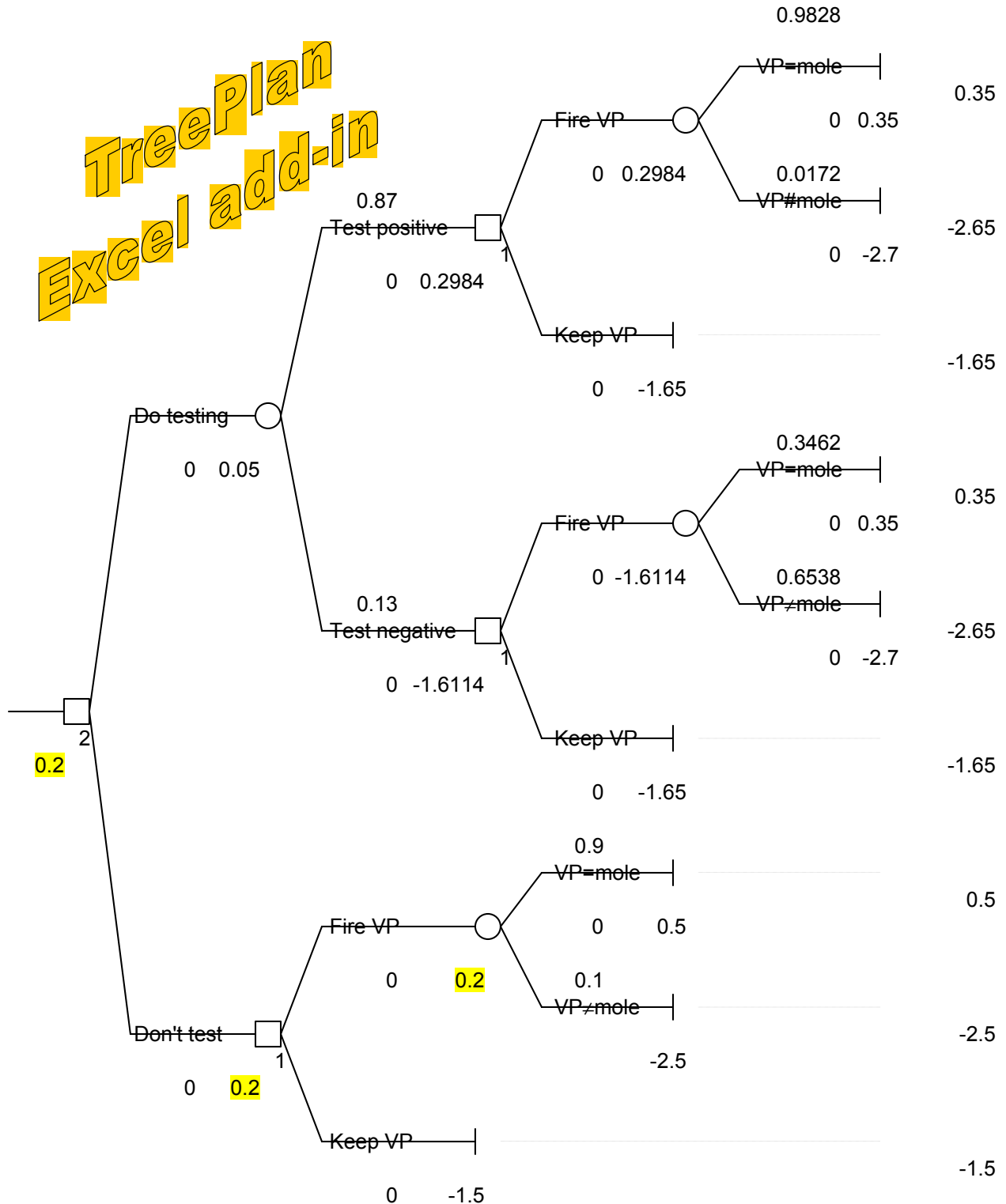

The optimal strategy is not to administer the lie detector test, but to fire the VP!