

## Chapter 2: Pressure Distribution in a Fluid

### Pressure and pressure gradient

In fluid statics, as well as in fluid dynamics, the forces acting on a portion of fluid (CV) bounded by a CS are of two kinds: body forces and surface forces.

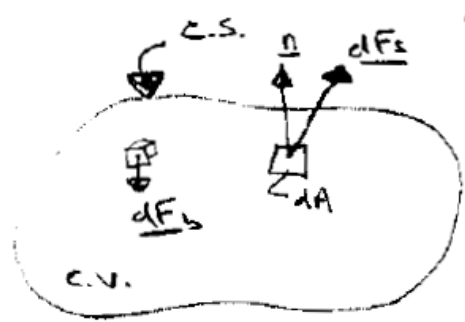

Body Forces: act on the entire body of the fluid (force per unit volume).

Surface Forces: act at the CS and are due to the surrounding medium (force/unit area-stress).

In general, the surface forces can be resolved into two components: one normal and one tangential to the surface. Considering a cubical fluid element, we see that the stress in a moving fluid comprises a 2<sup>nd</sup> order tensor.

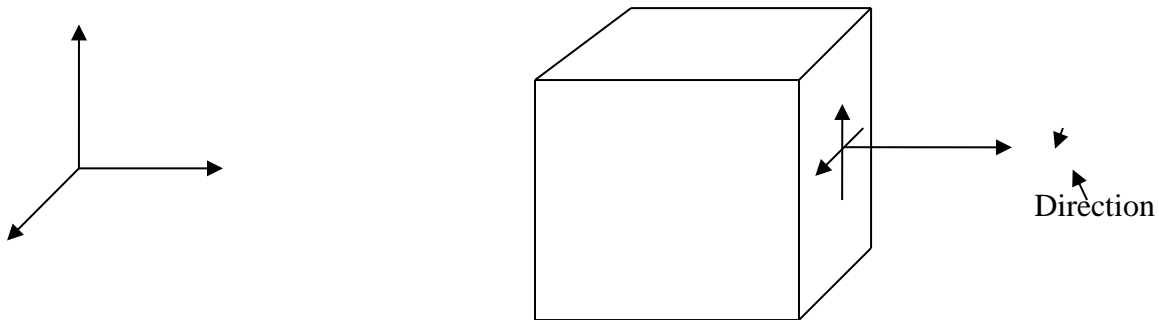

$$\sigma_{ij} = \begin{bmatrix} \sigma_{xx} & \sigma_{xy} & \sigma_{xz} \\ \sigma_{yx} & \sigma_{yy} & \sigma_{yz} \\ \sigma_{zx} & \sigma_{zy} & \sigma_{zz} \end{bmatrix}$$

Since by definition, a fluid cannot withstand a shear stress without moving (deformation), a stationary fluid must necessarily be completely free of shear stress ( $\sigma_{ij}=0, i \neq j$ ). The only non-zero stress is the normal stress, which is referred to as pressure:

$$\sigma_{ii} = -p$$

$\sigma_n = -p$ , which is compressive, as it should be since fluid cannot withstand tension. (Sign convention based on the fact that  $p > 0$  and in the direction of  $-\underline{n}$ )

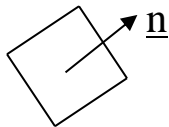

Or  $p_x = p_y = p_z = p_n = p$

(One value at a point, independent of direction;  $p$  is a scalar)

i.e. normal stress (pressure) is isotropic.

This can be easily seen by considering the equilibrium of a wedge-shaped fluid element  $V = 10^{-9} \text{ mm}^3$

$$\sum F_x : -p_n dA \sin \alpha + p_x dA \sin \alpha = 0$$

$$p_n = p_x$$

$$\sum F_z : -p_n dA \cos \alpha + p_z dA \cos \alpha - W = 0$$

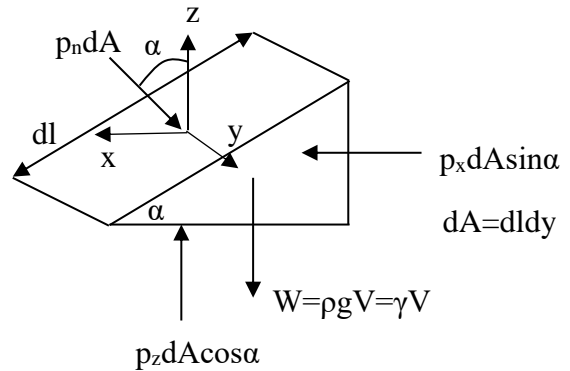

Where:

$$W = \gamma V \quad V = \Delta y \frac{1}{2} \Delta x \Delta z$$

$$\Delta x = \Delta l \cos \alpha \quad \Delta z = \Delta l \sin \alpha \quad \Delta y \Delta l = dA \Rightarrow \Delta y = dA / dl$$

$$W = \gamma dA \cos \alpha \frac{1}{2} dl \sin \alpha$$

$$\Rightarrow -p_n dA \cos \alpha + p_z dA \cos \alpha - \gamma dA \cos \alpha \frac{1}{2} dl \sin \alpha = 0$$

$$-p_n + p_z - \frac{\gamma}{2} dl \sin \alpha = 0$$

$$p_n = p_z \text{ for } dl \rightarrow 0 \text{ i.e. } p_n = p_x = p_y = p_z$$

Note: For a fluid in motion, the normal stress is different on each face and not equal to  $p$

$$\sigma_{xx} \neq \sigma_{yy} \neq \sigma_{zz} \neq -p$$

For an incompressible fluid, by convention  $p$  is defined as the average of the normal stresses:

$$p = \bar{p} = -\frac{1}{3}(\sigma_{xx} + \sigma_{yy} + \sigma_{zz}) = -\frac{1}{3}\sigma_{ii}$$

The fluid element experiences a force on it because of the fluid pressure distribution if it varies spatially.

Consider the net force in the x direction due to  $p(\underline{x}, t)$ .

$$dF_{x_{net}} = pdydz - \left( p + \frac{\partial p}{\partial x} dx \right) dydz$$

$$= -\frac{\partial p}{\partial x} dx dy dz$$

1<sup>st</sup> order  
Taylor  
series

The result will be similar for  $dF_y$  and  $dF_z$ ; consequently, we conclude:

$$d\underline{F}_{press} = \left[ -\frac{\partial p}{\partial x} \hat{i} - \frac{\partial p}{\partial y} \hat{j} - \frac{\partial p}{\partial z} \hat{k} \right] \Delta \nabla$$

Or:  $\underline{f} = -\nabla p$  force per unit volume due to  $p(\underline{x}, t)$ .

Note: if  $p = \text{constant}$ ,  $\underline{f} = 0$ .

## Equilibrium of a fluid element

Consider now a fluid element which is acted upon by both surface forces and a body force due to gravity:

$$\underline{dF}_{grav} = \rho \underline{g} d\underline{\nabla} \quad \text{or} \quad \underline{f}_{grav} = \rho \underline{g} \quad (\text{per unit volume})$$

Application of Newton's law yields:  $m\underline{a} = \sum \underline{F}$

$$\rho d\underline{\nabla} \underline{a} = (\sum \underline{f}) d\underline{\nabla}$$

$$\rho \underline{a} = \sum \underline{f} = \underline{f}_{body} + \underline{f}_{surface} \quad \text{per unit } d\underline{\nabla}$$

$$\underline{f}_{body} = \rho \underline{g} \quad \text{and} \quad \underline{g} = -g \hat{k} \Rightarrow \underline{f}_{body} = -\rho g \hat{k} \quad \begin{matrix} z \uparrow \\ g \downarrow \end{matrix}$$

$$\underline{f}_{surface} = \underline{f}_{pressure} + \underline{f}_{viscous}$$

(Includes  $\underline{f}_{viscous}$ , since in general  $\sigma_{ij} = -p\delta_{ij} + \tau_{ij}$ )

$$\underline{f}_{pressure} = -\nabla p$$

Viscous part

$$\underline{f}_{viscous} = \mu \left[ \frac{\partial^2 \underline{V}}{\partial x^2} + \frac{\partial^2 \underline{V}}{\partial y^2} + \frac{\partial^2 \underline{V}}{\partial z^2} \right] = \mu \nabla^2 \underline{V}$$

For  $\rho, \mu = \text{constant}$ , the viscous force will have this form (chapter 4).

$$\rho \underline{a} = \underbrace{-\nabla p}_{\text{pressure gradient}} + \underbrace{\rho \underline{g}}_{\text{gravity}} + \underbrace{\mu \nabla^2 \underline{V}}_{\text{viscous}} \quad \text{with} \quad \underline{a} = \frac{\partial \underline{V}}{\partial t} + \underline{V} \cdot \nabla \underline{V}$$

Note that  $\underline{V} \cdot \nabla \underline{V}$  is nonlinear, i.e., product of unknowns!

This is called the Navier-Stokes equation and will be discussed further in Chapter 4. Consider solving the N-S equation for  $p$  when  $\underline{a}$  and  $\underline{V}$  are known.

$$\nabla p = \rho(\underline{g} - \underline{a}) + \mu \nabla^2 \underline{V} = \underline{B}(\underline{x}, t)$$

This is simply a first order PDE for  $p$  and can be solved readily. For the general case ( $\underline{V}$  and  $p$  unknown), one must solve the NS and continuity equations, which is a formidable task since the NS equations are a system of 2<sup>nd</sup> order nonlinear PDEs.

We now consider the following special cases:

1) Hydrostatics ( $\underline{a} = \underline{V} = 0$ )

2) Rigid body translation or rotation ( $\nabla^2 \underline{V} = 0$ )<sup>1</sup>

3) Irrotational motion ( $\nabla \times \underline{V} = 0$ )

$$\underbrace{\nabla \times (\nabla \times \underline{b}) = \nabla(\nabla \cdot \underline{b}) - \nabla^2 \underline{b}}_{\text{vector identity}}$$

For vector  $\underline{b} = \underline{V}$

$\nabla \times \underline{V} = 0 \Rightarrow$  if  $\rho = \text{constant}$   $\nabla^2 \underline{V} = 0 \Rightarrow$  Euler equation  $\Rightarrow \int \Rightarrow$  Bernoulli equation  
 also,

$$\nabla \times \underline{V} = 0 \Rightarrow \underline{V} = \nabla \phi \ \& \ \text{if } \rho = \text{const.} \Rightarrow \nabla^2 \phi = 0$$

---

<sup>1</sup> No viscous stresses since volume fluid element does not deform in shape or size.

## **Case (1) Hydrostatic Pressure Distribution**

$$\nabla p = \rho \underline{g} = -\rho g \mathbf{k} \quad z \uparrow \quad \downarrow g$$

$$\text{i.e. } \frac{\partial p}{\partial x} = \frac{\partial p}{\partial y} = 0 \quad \text{and} \quad \frac{\partial p}{\partial z} = -\rho g \quad dp = -\rho g dz$$

$$\text{or } p_2 - p_1 = -\int_1^2 \rho g dz = -g \int_1^2 \rho(z) dz$$

Spherical planet uniform density  $g = g_0 \left(\frac{r_0}{r}\right)^2 \cong$   
constant near earth's surface  $r_0$

liquids  $\rightarrow \rho = \text{constant (for one liquid)}$   
 $p = -\rho g z + \text{constant}$

( $z = 0$ ,  $p = \text{constant} = p_{\text{atm}}$ ;  $p$  increases  $z < 0$  and decreases  $z > 0$ )

gases  $\rightarrow \rho = \rho(p, t)$  which is known from the equation  
of state:  $p = \rho R T \rightarrow \rho = p / R T$

$\frac{dp}{p} = -\frac{g}{R T(z)} dz$  which can be integrated if  $T = T(z)$  is  
known as it is for the atmosphere.

## Manometry

Manometers are devices that use liquid columns for measuring differences in pressure. A general procedure may be followed in working all manometer problems:

- 1.) Start at one end (or a meniscus if the circuit is continuous) and write the pressure there in an appropriate unit or symbol if it is unknown.
- 2.) Add to this the change in pressure (in the same unit) from one meniscus to the next (plus if the next meniscus is lower, minus if higher).
- 3.) Continue until the other end of the gage (or starting meniscus) is reached and equate the expression to the pressure at that point, known or unknown.

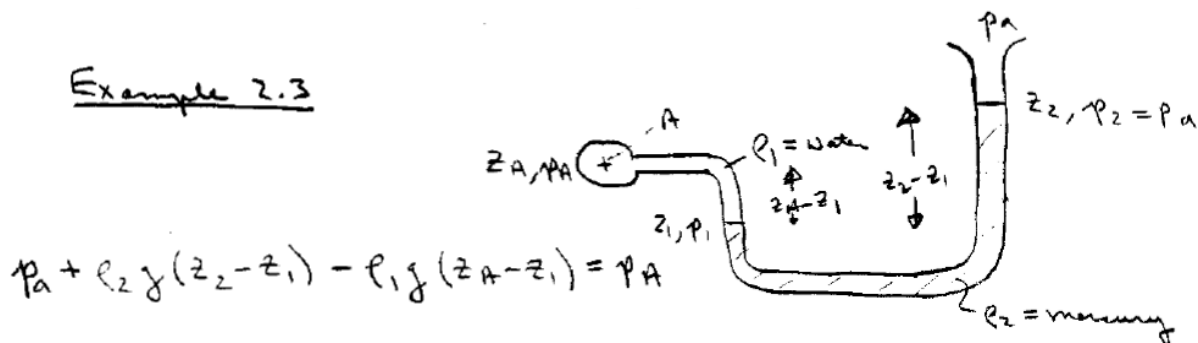



## Hydrostatic forces on plane surfaces

The force on a body due to a pressure distribution is:

$$\underline{F} = - \int_A p \underline{n} dA$$

where for a plane surface  $\underline{n} = \text{constant}$  and we need only consider  $|\underline{F}|$  noting that its direction is always towards the surface:  $|\underline{F}| = \int_A p dA$ .

Consider a plane surface  $\overline{AB}$  entirely submerged in a liquid such that the plane of the surface intersects the free surface with an angle  $\alpha$ . The centroid of the surface is denoted  $(\bar{x}, \bar{y})$ .

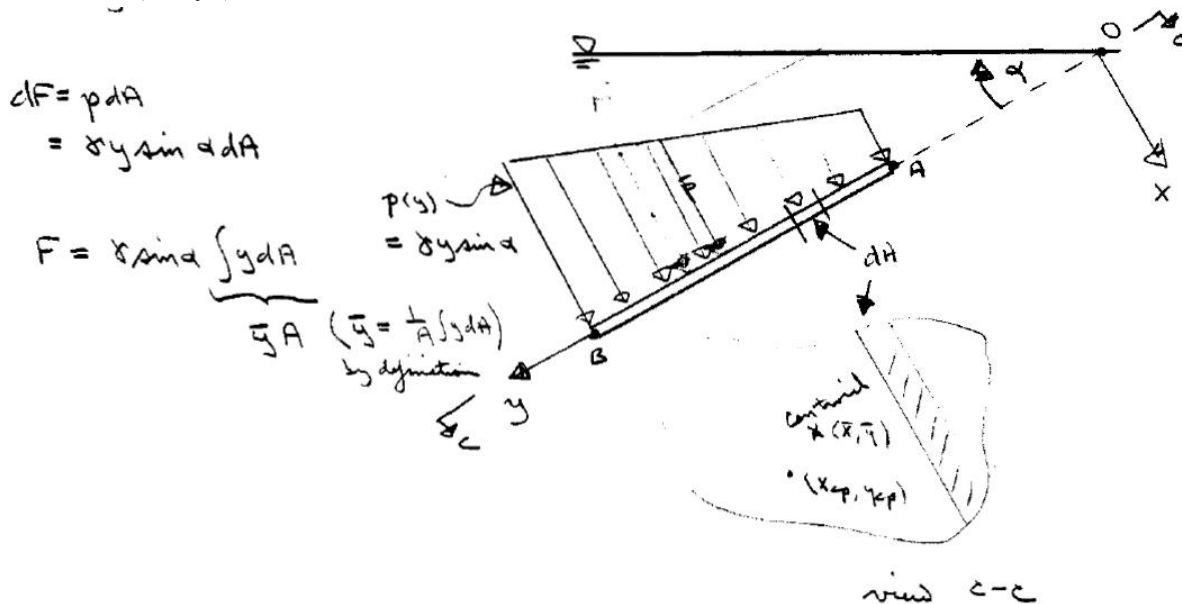

$$F = \gamma \sin \alpha \bar{y} A = \bar{p} A$$

Where  $\bar{p}$  is the pressure at the centroid.

To find the line of action of the force which we call the center of pressure ( $x_{cp}$ ,  $y_{cp}$ ) we equate the moment of the resultant force to that of the distributed force about any arbitrary axis.

$$y_{cp} F = \int_A y dF$$

$$= \gamma \sin \alpha \int_A y^2 dA \quad \text{Note: } dF = \gamma y \sin \alpha dA$$

$$\int_A y^2 dA = I_o \rightarrow \text{moment of Inertia about } O - O$$

$$= \bar{y}^2 A + \bar{I}$$

$\bar{I} = \text{moment of inertia WRT horizontal centroidal axis}$

$$\rightarrow F = \bar{p}A = \gamma \sin \alpha \bar{y}A$$

$$\rightarrow y_{cp} \gamma \sin \alpha \bar{y}A = \gamma \sin \alpha (\bar{y}^2 A + \bar{I})$$

$$\rightarrow \boxed{y_{cp} = \bar{y} + \frac{\bar{I}}{\bar{y}A}}$$

and similarly, for  $x_{cp}$

$$x_{cp} F = \int_A x dF$$

where

$\bar{I}_{xy} = \text{product of inertia}$

$$I_{xy} = \bar{I}_{xy} + \bar{x}\bar{y}A$$

$$\boxed{x_{cp} = \frac{\bar{I}_{xy}}{\bar{y}A} + \bar{x}}$$

Note that the coordinate system in the text has its origin at the centroid and is related to the one just used by:

$$x_{text} = x - \bar{x} \quad \text{and} \quad y_{text} = -(y - \bar{y})$$

## Hydrostatic Forces on Curved Surfaces

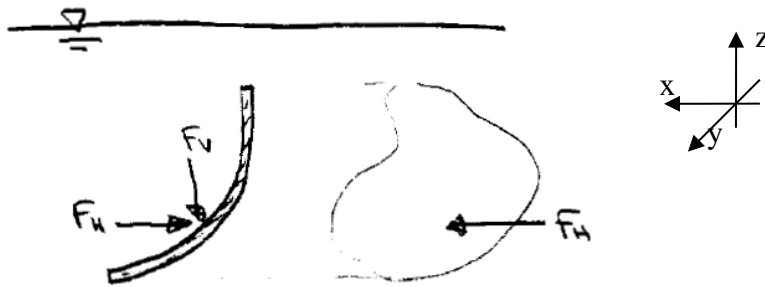

In general,

$$\underline{F} = -\int_A p \underline{n} dA$$

Horizontal Components:

$$F_x = \underline{F} \cdot \hat{i} = -\int p \underbrace{\underline{n} \cdot \hat{i}}_{dA_x} dA$$

$$F_y = -\int_{A_y} p dA_y$$

$dA_x$  = projection of  $\underline{n} dA$  onto a plane perpendicular to x direction  
 $dA_y$  = projection of  $\underline{n} dA$  onto a plane perpendicular to y direction

The horizontal component of force acting on a curved surface is equal to the force acting on a vertical projection of that surface including both magnitude and line of action and can be determined by the methods developed for plane surfaces.

$$F_z = -\int p \underline{n} \cdot \hat{k} dA = -\int_{A_z} p dA_z = \gamma \int_{A_z} h dA_z = \gamma \nabla$$

Where  $h$  is the depth to any element area  $dA$  of the surface. The vertical component of force acting on a curved surface is equal to the net weight of the total column of fluid directly above the curved surface and has a line of action through the centroid of the fluid volume.

## Example Drum Gate

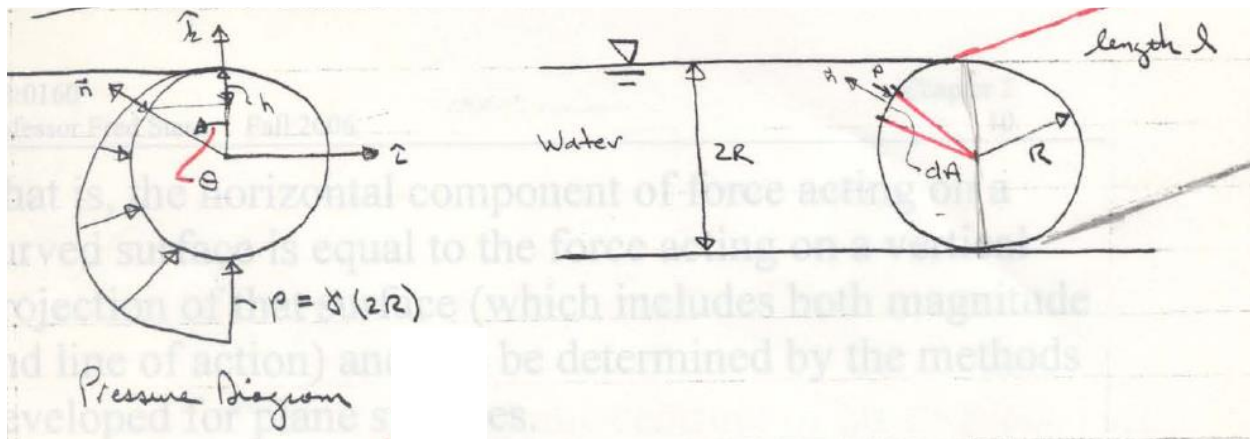

$$h = R - R \cos \theta = R(1 - \cos \theta)$$

$$p = \gamma h = \underbrace{\gamma R(1 - \cos \theta)}_h$$

$$\vec{n} = -\sin \theta \hat{i} + \cos \theta \hat{k}$$

$$dA = lR d\theta$$

$$\underline{F} = -\int_0^\pi \underbrace{\gamma R(1 - \cos \theta)}_p \underbrace{(-\sin \theta \hat{i} + \cos \theta \hat{k})}_n \underbrace{lR d\theta}_{dA}$$

$$\underline{F} \cdot \hat{i} = F_x = \gamma R^2 \int_0^\pi (1 - \cos \theta) \sin \theta d\theta$$

$$= \gamma R^2 \left( -\cos \theta \Big|_0^\pi + \frac{1}{4} \cos 2\theta \Big|_0^\pi \right) = 2\gamma R^2$$

$$= \underbrace{\gamma R^2}_p \underbrace{2Rl}_A$$

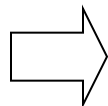

Same force as that on projection of gate onto vertical plane perpendicular direction

$$F_z = -\gamma l R^2 \int_0^\pi (1 - \cos\theta) \cos\theta d\theta$$

$$= -\gamma l R^2 \left( \sin\theta - \frac{\theta}{2} - \frac{1}{4} \sin 2\theta \right)_0^\pi$$

$$= -\gamma l R^2 \frac{\pi}{2} = \gamma l \left( \frac{\pi R^2}{2} \right) = \gamma V$$

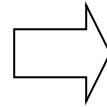

Net weight of water above curved surface

Another approach:

$$F_1 = \gamma l \left[ R^2 - \frac{1}{4} \pi R^2 \right]$$
$$= \gamma l R^2 \left[ 1 - \frac{1}{4} \pi \right]$$

$$F_2 = \gamma l \frac{\pi R^2}{2} + F_1$$

$$F = F_2 - F_1 = \frac{\gamma l \pi R^2}{2}$$



## Buoyancy and Stability

### Archimedes Principle

$$F_B = F_{V(2)} - F_{V(1)}$$

= fluid weight above 2<sub>ABC</sub> -  
fluid weight above 1<sub>ADC</sub>

= weight of fluid equivalent  
to the body volume

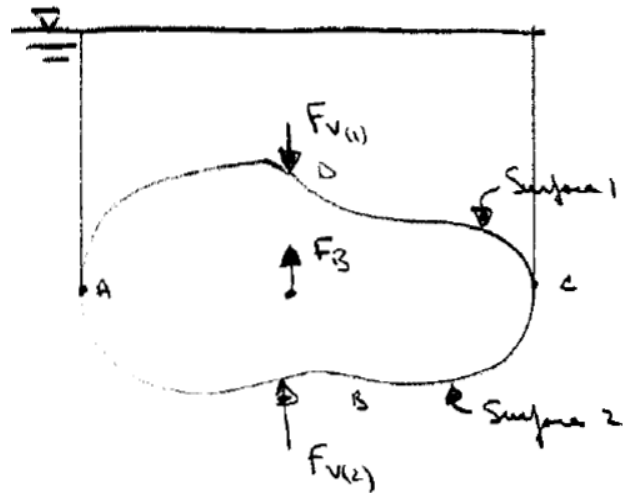

In general,  $F_B = \rho g \nabla$  ( $\nabla$  = submerged volume).

The line of action is through the centroid of the displaced volume, which is called the center of buoyancy.

Example: Floating body in “dynamic” heave motion

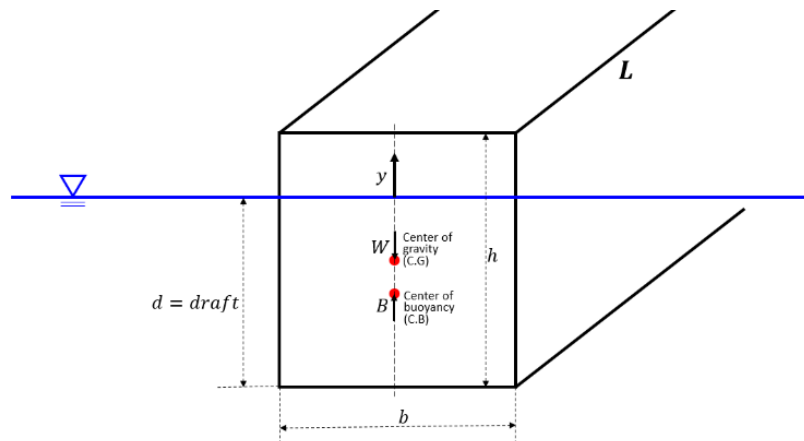

Weight of the block  $W = \rho_b Lbhg = mg = \gamma \nabla_0$  where  $\nabla_0$  is displaced water volume by the block for initial static equilibrium position and  $\gamma$  is the specific weight of the liquid.

$$W = B \Rightarrow \underbrace{\rho_b Lbhg}_W = \underbrace{\rho_w Lbdg}_B \Rightarrow d = \frac{\rho_b}{\rho_w} h = S_b h$$

$S_b = \text{specific gravity of the block}$

$$\rho_b = \rho_w : d = h$$

$$\rho_b > \rho_w : d > h \quad \text{sink}$$

$$\rho_b < \rho_w : d < h \quad \text{floating}$$

**Instantaneous displaced water volume:**

$$\nabla = \nabla_0 - yA_{wp}$$

$$\begin{aligned} \sum F_V = m \ddot{y} &= B - W = \gamma \nabla - \gamma \nabla_0 \\ &= -\gamma A_{wp} y \end{aligned}$$

$$y > 0: \nabla \downarrow B \downarrow$$

$$y < 0: \nabla \uparrow B \uparrow$$

$$m \ddot{y} + \gamma A_{wp} y = 0$$

$$\ddot{y} + \frac{\gamma A_{wp}}{m} y = 0$$

$$y = A \cos \omega_n t + B \sin \omega_n t$$

Use initial condition ( $t=0, y = y_0, \dot{y} = \dot{y}_0$ ) to determine A and B:

$$y = y_0 \cos \omega_n t + \frac{\dot{y}_0}{\omega_n} \sin \omega_n t$$

Where

$$\omega_n = \sqrt{\frac{\gamma A_{wp}}{m}}$$

period

$$T = \frac{2\pi}{\omega} = 2\pi \sqrt{\frac{m}{\gamma A_{wp}}}$$

Spar Buoy

T is tuned to decrease response to ambient waves: we can increase T by increasing block mass  $m$  and/or decreasing waterline area  $A_{wp}$ .



## Stability of Immersed and Floating Bodies

Here we'll consider transverse stability. In actual applications both transverse and longitudinal stability are important.

### Immersed Bodies

FIGURE 3.15  
*Conditions of stability for immersed bodies.*  
(a) Stable. (b) Neutral.  
(c) Unstable.

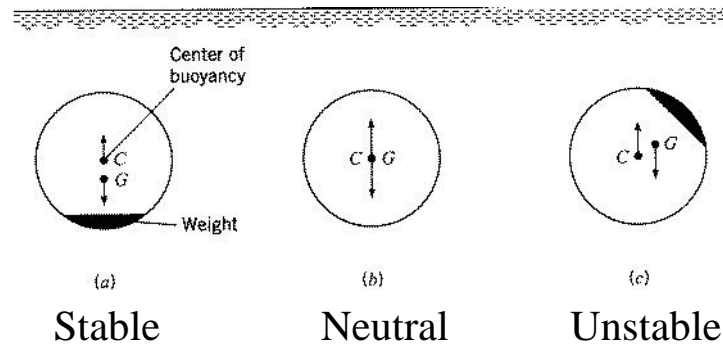

Static equilibrium requires:  $\sum F_v = 0$  and  $\sum M = 0$

$\sum M = 0$  requires that the centers of gravity and buoyancy coincide, i.e.,  $C = G$  and body is neutrally stable

If C is above G, then the body is stable (righting moment when heeled)

If G is above C, then the body is unstable (heeling moment when heeled)

## Floating Bodies

For a floating body the situation is more complicated since the center of buoyancy will generally shift when the body is rotated depending upon the shape of the body and the position in which it is floating.

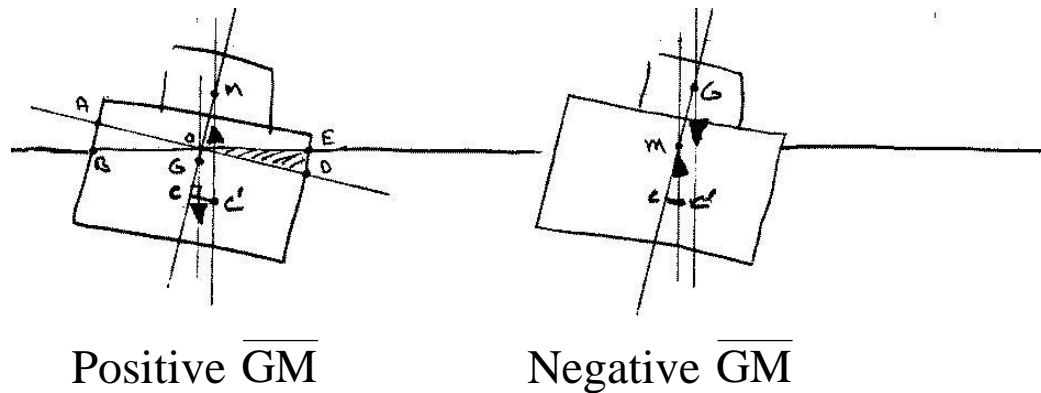

The center of buoyancy (centroid of the displaced volume) shifts laterally to the right for the case shown because part of the original buoyant volume AOB is transferred to a new buoyant volume EOD.

The point of intersection of the lines of action of the buoyant force before and after heel is called the metacenter M and the distance GM is called the metacentric height. If GM is positive, that is, if M is above G, then the ship is stable; however, if GM is negative, the ship is unstable.

$\alpha =$  small heel angle

$\bar{x} = CC' =$  lateral displacement of C

C = center of buoyancy  
 i.e., centroid of displaced volume  $\nabla$

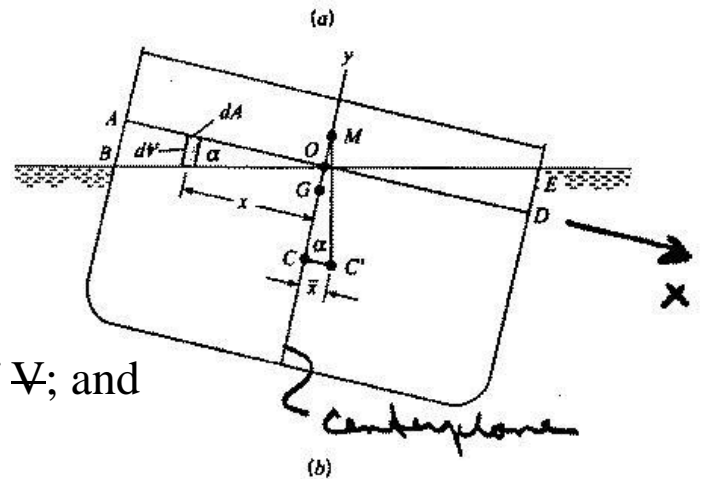
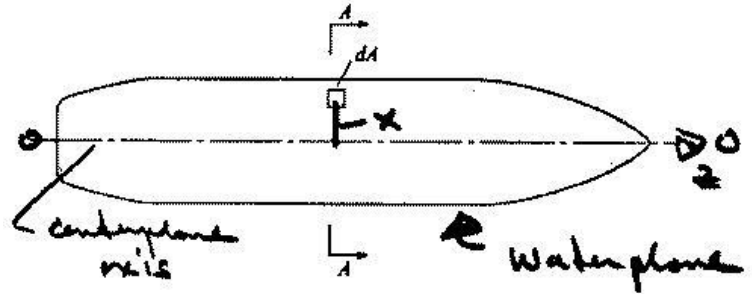

Solve for GM: find  $\bar{x}$  using:

- (1) basic definition for centroid of  $\nabla$ ; and
- (2) trigonometry

**(1) Basic definition of centroid of volume  $\nabla$**

$$\bar{x}\nabla = \int x dV = \sum x_i \Delta V_i \quad \text{moment about center plane}$$

$$\begin{aligned} \bar{x}\nabla &= \underbrace{\text{moment } V \text{ before heel}} - \text{moment of } \nabla_{AOB} \\ &\quad + \text{moment of } \nabla_{EOD} \\ &= 0 \text{ due to symmetry of} \\ &\quad \text{original } V \text{ about } y \text{ axis} \\ &\quad \text{i.e., ship center plane} \end{aligned}$$

$$\bar{x}\nabla = - \int_{AOB} (-x) dV + \int_{EOD} x dV$$

$$dV = y dA = x \tan \alpha dA \quad (\tan \alpha = y/x)$$

$$\bar{x}\nabla = \int_{AOB} x^2 \tan \alpha dA + \int_{EOD} x^2 \tan \alpha dA$$

$$\bar{x}\nabla = \tan \alpha \int x^2 dA$$

$\underbrace{\hspace{10em}}$   
 ship waterplane area

moment of inertia of ship waterplane  
 about z axis O-O; i.e.,  $I_{OO}$

$I_{OO}$  = moment of inertia of waterplane  
 area about center plane axis

(2) **Trigonometry**

$$\bar{x}\nabla = \tan \alpha I_{OO}$$

$$CC' = \bar{x} = \frac{\tan \alpha I_{OO}}{\nabla} = CM \tan \alpha$$

$$CM = I_{OO} / \nabla$$

$$GM = CM - CG$$

$$GM = \frac{I_{OO}}{\nabla} - CG$$

$GM > 0$       Stable

$GM < 0$       Unstable

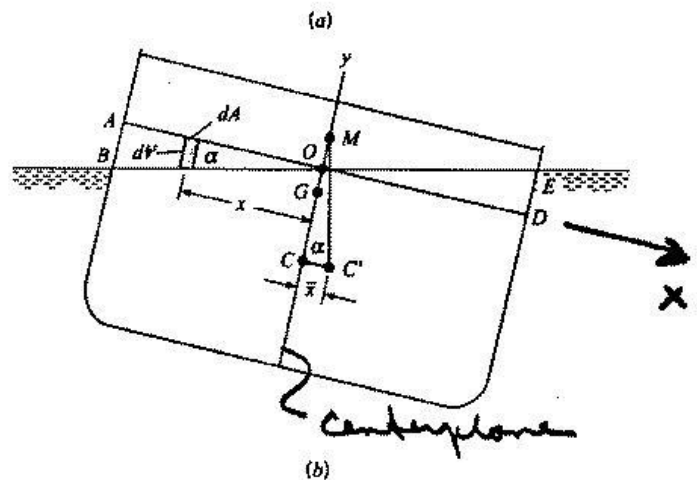
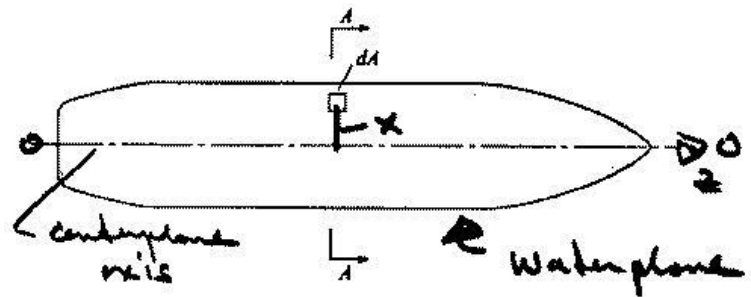

**Roll:** The “dynamic” rotation of a ship about the longitudinal axis through the center of gravity.

Consider symmetrical ship heeled to a very small angle  $\theta$ . Solve for the subsequent motion due only to hydrostatic and gravitational forces.

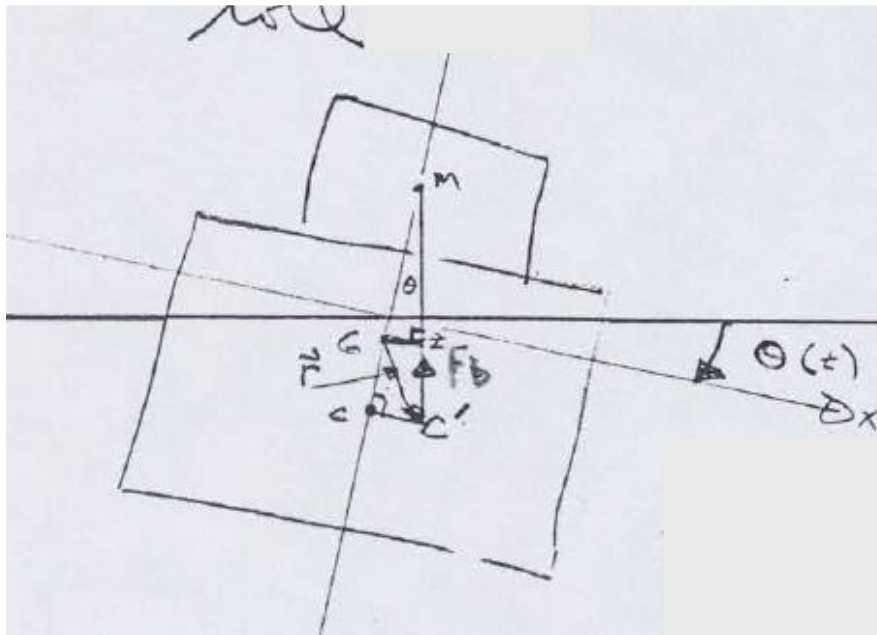

$$\underline{F}_b = (\cos\theta\hat{j} - \sin\theta\hat{i})\rho g \nabla \quad (\rho g \nabla = \Delta = \text{displacement})$$

$$\underline{M}_g = \underline{r} \times \underline{F}_b$$

$$\begin{aligned} \underline{M}_g &= (-GC\hat{j} + CC'\hat{i}) \times \Delta(\cos\theta\hat{j} - \sin\theta\hat{i}) \\ &= (-GC\sin\theta + CC'\cos\theta)\Delta\hat{k} \\ &= (-GC + CM)\sin\theta\Delta\hat{k} \\ &= GM\sin\theta\Delta\hat{k} \end{aligned}$$

Note:  $\tan\theta = CC'/CM = GZ/GM = \sin\theta/\cos\theta$   
 $CC'\cos\theta = CM\sin\theta$

Note: recall that  $M_o = |\overline{F}| \cdot d$ , where d is the perpendicular distance from O to the line of action of  $\overline{F}$ .

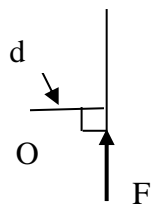

$$\begin{aligned} M_G &= GZ \Delta \\ &= GM \sin\theta \Delta \end{aligned}$$

$$\sum M_G = -I \ddot{\theta}$$

$I$  = mass moment of inertia about long axis through G

$\ddot{\theta}$  = angular acceleration

$$I \ddot{\theta} + \Delta GM \sin \theta = 0$$

for small  $\theta$ :  $\ddot{\theta} + \frac{\Delta GM}{I} \theta = 0$

$$\frac{\Delta GM}{I} = \frac{\rho g \nabla GM}{I} = \frac{mgGM}{I}$$

$k = \sqrt{I/m}$  definition of radius of gyration

$$k^2 = I/m \quad mk^2 = I \quad \frac{\Delta GM}{I} = \frac{gGM}{k^2}$$

The solution to this equation is,

$$\theta(t) = \theta_o \cos \omega_n t + \frac{\dot{\theta}_o}{\omega_n} \sin \omega_n t$$

0 for no initial velocity

where  $\theta_o$  = the initial heel angle

$\omega_n$  = natural frequency

$$= \sqrt{\frac{gGM}{k^2}} \quad = \frac{\sqrt{gGM}}{k}$$

Simple (undamped) harmonic oscillation:

The period of the motion is  $T = \frac{2\pi}{\omega_n} \quad T = \frac{2\pi k}{\sqrt{gGM}}$

Note that large GM decreases the period of roll, which would make for an uncomfortable boat ride (high frequency oscillation).

Earlier we found that GM should be positive if a ship is to have transverse stability and, generally speaking, the stability is increased for larger positive GM. However, the present example shows that one encounters a “design tradeoff” since large GM decreases the period of roll, which makes for an uncomfortable ride.

## Parametric Roll:

The periodicity of the encounter wave causes variations of the metacentric height i.e.  $GM=GM(t)$ . Therefore:

$$I \ddot{\theta} + \Delta GM(t)\theta = 0$$

Assuming  $GM(t) = GM_0 + GM_1 \cos(\omega t)$ :

$$I \ddot{\theta} + \Delta (GM_0 + GM_1 \cos(\omega t))\theta = 0 \Rightarrow$$

$$\ddot{\theta} + (\omega_n^2 + C \cos(\omega_e t))\theta = 0$$

where

$$\omega_n = \frac{\sqrt{gGM_0}}{k}; \quad C = \frac{GM_1}{GM_0}; \quad \Delta = mg; \quad I = mk^2; \quad \text{and } \omega_e = \text{encounter wave freq.}$$



By changing of variables ( $\tau = \omega_e t$ ):

$$\ddot{\theta}(\tau) + \delta(1 + C \cos \tau)\theta(\tau) = 0 \quad \text{and} \quad \delta = \frac{\omega_n^2}{\omega_e^2}$$

This ordinary 2nd order differential equation where the restoring moment varies sinusoidally, is known as the Mathieu equation. This equation gives unbounded solution (i.e. it is unstable) when

$$\delta = \frac{\omega_n^2}{\omega_e^2} = \left(\frac{2n+1}{2}\right)^2 \quad n = 0, 1, 2, 3, \dots$$

For the principle parametric roll resonance,  $n=0$  i.e.,

$$\omega_e = 2\omega_n \quad \frac{2\pi}{T_e} = 2 \times \frac{2\pi}{T_n} \Rightarrow T_n = 2T_e$$

[Hosseini, H., Stern, F., Olivieri, A., Campana, E., Hashimoto, H., Umeda, N., Bulian, G. and Francescutto, A., "Head-Waves Parametric Rolling of Surface Combatant," Ocean Engineering, Vol. 37, Issue 10, July 2010, pp. 859 – 878.](#)



## **Case (2) Rigid Body Translation or Rotation**

In rigid body motion, all particles are in combined translation and/or rotation and there is no relative motion between particles; consequently, there are no strains or strain rates, and the viscous term drops out of the Navier-Stokes (NS) equations ( $\mu \nabla^2 \underline{v} = 0$ ).

$$\nabla p = \rho(\underline{g} - \underline{a})$$

from which we see that  $\nabla p$  acts in the direction of  $(\underline{g} - \underline{a})$ , and lines of constant pressure must be perpendicular to this direction (by definition,  $\nabla f$  is perpendicular to  $f = \text{constant}$ ).

The NS equations are derived for an inertial reference frame and must be transformed for a non-inertial reference frame for the present purposes of rigid body motion, which is a simplification of the more general case of non-rigid body fluid motion.

FIGURE 4.6 Geometry showing the relationship between a stationary coordinate system  $O123$  and a noninertial coordinate system  $O'1'2'3'$  that is moving, accelerating, and rotating with respect to  $O123$ . In particular, the vector connecting  $O$  and  $O'$  is  $\underline{X}(t)$  and the rotational velocity of  $O'1'2'3'$  is  $\underline{\Omega}(t)$ . The vector velocity  $\underline{u}$  at point  $P$  in  $O123$  is shown. The vector velocity  $\underline{u}'$  at point  $P$  in  $O'1'2'3'$  differs from  $\underline{u}$  because of the motion of  $O'1'2'3'$ .

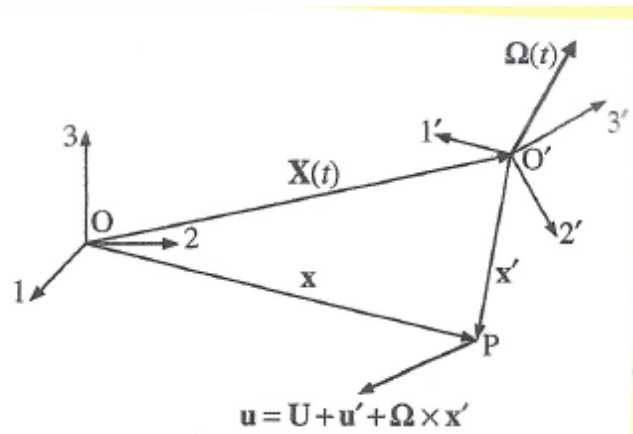

General case discussed after NS equations derived is required for rotating machinery, maneuvering vehicles, geophysical flows (atmospheric, oceanic), etc.

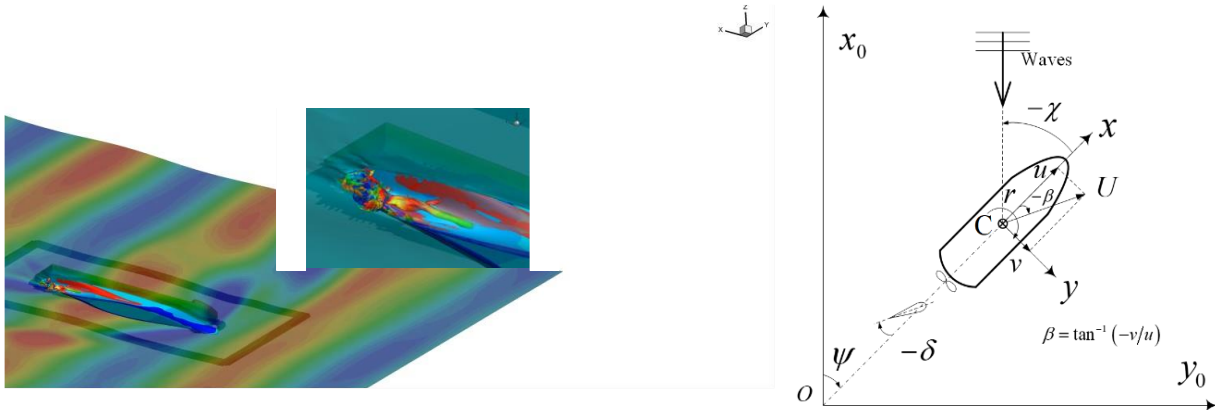

[KCS movie](#)

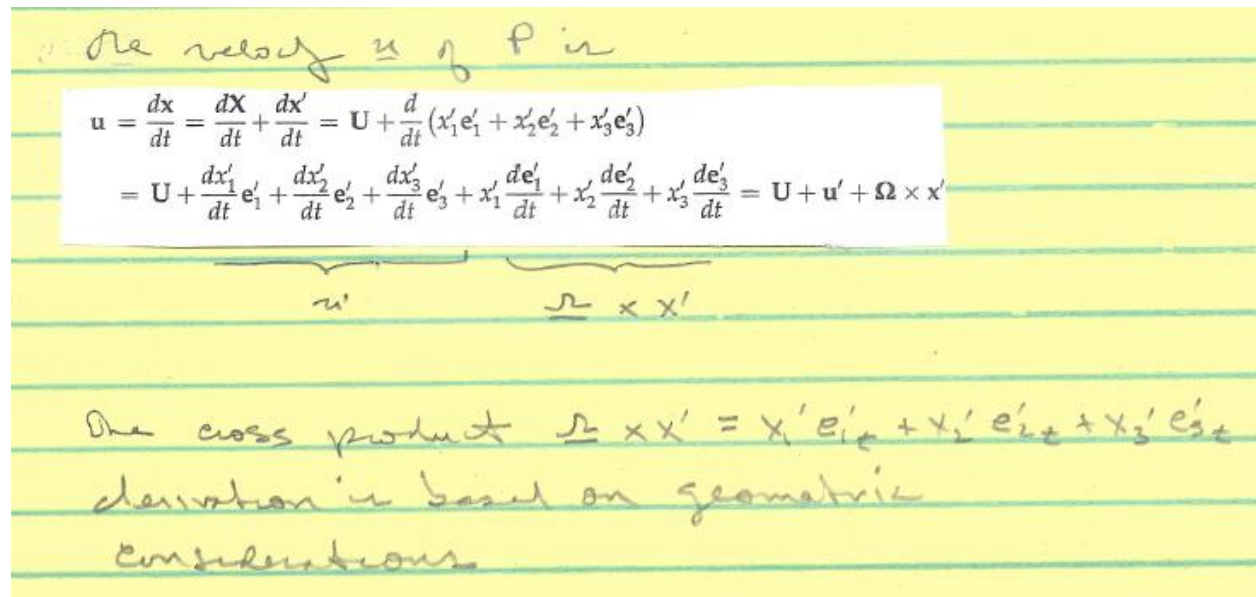

O' translates at  $\underline{U}$  and rotates at  $\underline{\Omega}$  = the angular velocity vector relative to O.

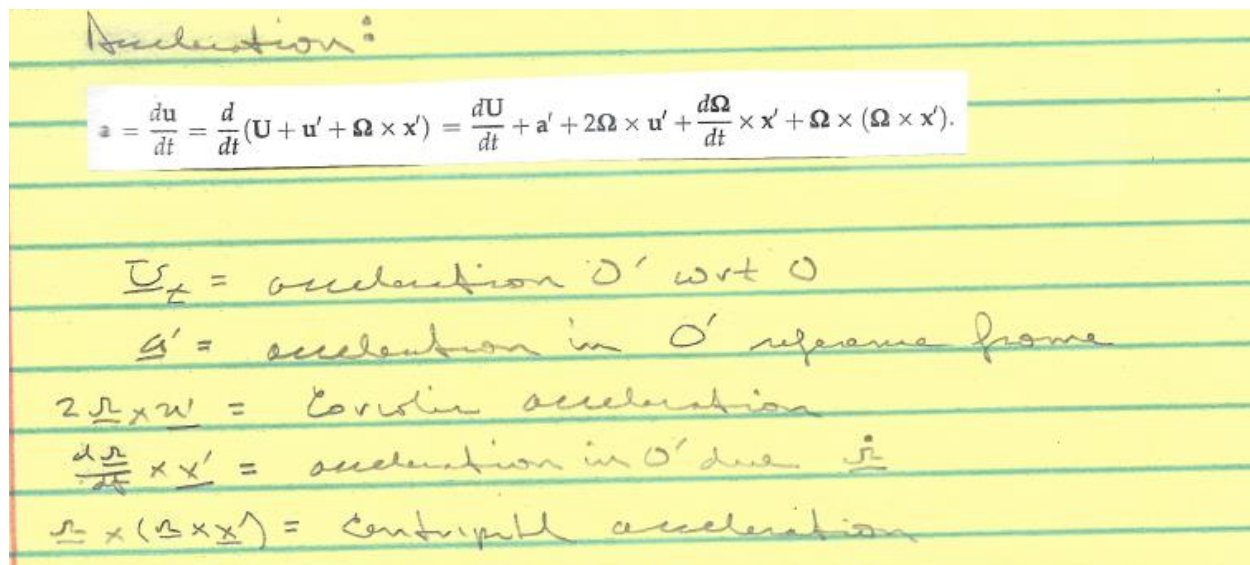

Usually, all these terms are not present simultaneously. In fact, fluids can rarely move in rigid body motion unless restrained by confining walls. Here we consider (1) rigid body acceleration and (2) rigid body rotation, as an introduction to pressure variation in a moving fluid.

For rigid body motion  $\underline{u}' = 0$ , as all fluid particles in the non-inertial reference frame move at the same velocity, i.e.,

$$\underline{u} = \underline{U} + \underline{\Omega} \times \underline{x}'$$

$$\frac{d\underline{u}}{dt} = \underline{a} = \frac{d\underline{U}}{dt} + \underline{\Omega} \times (\underline{\Omega} \times \underline{x}') + \frac{d\underline{\Omega}}{dt} \times \underline{x}'$$

### (1) Uniform Linear Acceleration

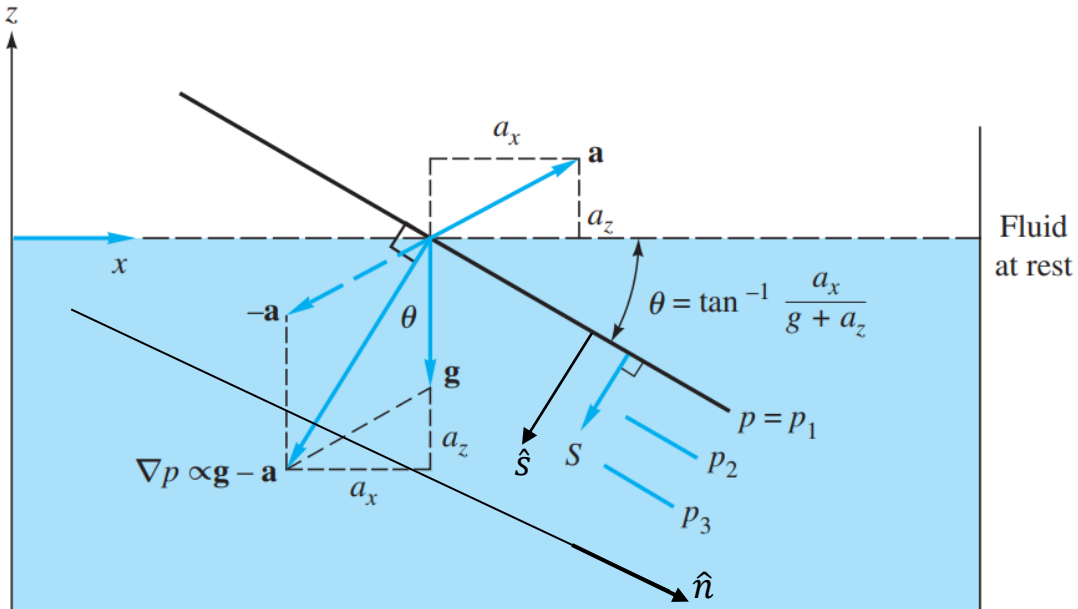

$$\nabla p = \rho(\underline{g} - \underline{a}) = \text{Constant}$$

$$= -\rho[(g + a_z)\hat{k} + a_x\hat{i}]$$

$$\frac{\partial p}{\partial x} = -\rho a_x$$

1.  $a_x < 0$        $p$  increase in  $+x$
2.  $a_x > 0$        $p$  decrease in  $+x$

$$\frac{\partial p}{\partial z} = -\rho(g + a_z)$$

1.  $a_z > 0$                        $p$  decrease in  $+z$
2.  $a_z < 0$  and  $|a_z| < g$        $p$  decrease in  $+z$  but slower than  $g$
3.  $a_z < 0$  and  $|a_z| > g$        $p$  increase in  $+z$

unit vector in the direction of  $\nabla p$ :

$$\hat{s} = \frac{\nabla p}{|\nabla p|} = \frac{(g + a_z)k + a_x \hat{i}}{\left[ (g + a_z)^2 + a_x^2 \right]^{\frac{1}{2}}}$$

lines of constant pressure are perpendicular to  $\nabla p$ .

$$n = \hat{s} \times j = \frac{a_x k - (g + a_z) \hat{i}}{\left[ a_x^2 + (g + a_z)^2 \right]^{\frac{1}{2}}}$$

unit vector in direction of  $p = \text{constant}$

angle between  $n$  and  $x$  axes:

$$\theta = \tan^{-1} \frac{a_x}{(g + a_z)}$$

The pressure variation in the direction of  $\nabla P$  is greater than in ordinary hydrostatics; that is:

$$\frac{dp}{ds} = \nabla p \cdot \hat{s} = \rho \underbrace{\left[ a_x^2 + (g + a_z)^2 \right]^{\frac{1}{2}}}_G \quad \text{which is } > \rho g$$

$$\begin{aligned} p &= \rho G s + \text{constant} \\ &= \rho G s \quad \text{gage pressure} \end{aligned}$$

### (3) Rigid Body Rotation

Consider a cylindrical tank of liquid rotating at a constant rate  $\underline{\Omega} = \Omega \hat{k}$  :

Fig. 2.22 Development of paraboloid constant-pressure surfaces in a fluid in rigid-body rotation. The dashed line along the direction of maximum pressure increase is an exponential curve.

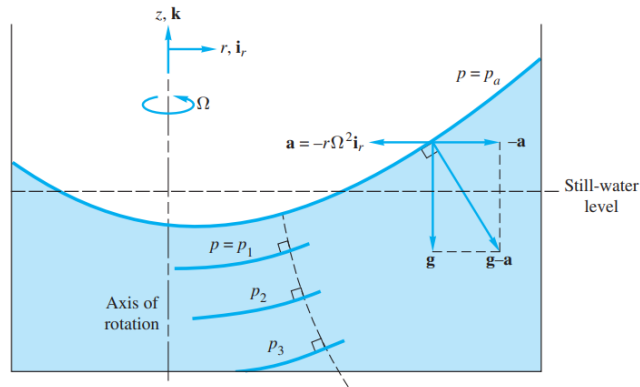

$$\nabla p = \rho(\underline{g} - \underline{a})$$

$$\underline{a} = \underline{\Omega} \times (\underline{\Omega} \times \underline{r}_0) = -r\Omega^2 \hat{e}_r$$

$$\nabla p = \rho(\underline{g} - \underline{a}) = -\rho g \hat{k} + \rho r \Omega^2 \hat{e}_r$$

i.e.  $\frac{\partial p}{\partial r} = \rho r \Omega^2$        $\frac{\partial p}{\partial z} = -\rho g$

integrate with respect to r:  $p = \frac{\rho}{2} r^2 \Omega^2 + f(z) + c$

integrate with respect to z:  $p = f(r) + -\rho g z + C$

$$f(z) = -\rho g z + C$$

$$p = \frac{\rho}{2} r^2 \Omega^2 - \rho g z + \text{Constant}$$

The constant is determined by specifying the pressure at one point; say,  $p = p_0$  at  $(r,z) = (0,0)$ .

$$p = p_0 - \rho g z + \frac{\rho}{2} r^2 \Omega^2$$

(Note: Pressure is linear in  $z$  and parabolic in  $r$ )

Curves of constant pressure  $p=p_1$  are given by:

$$z = \frac{p_0 - p_1}{\rho g} + \frac{r^2 \Omega^2}{2g} = a + br^2$$

which are paraboloids of revolution, concave upward, with their minimum points on the axis of rotation.

The unit vector in the direction of  $\nabla p$  is:

$$\hat{s} = \frac{-\rho g \hat{k} + \rho r \Omega^2 \hat{e}_r}{\left[ (\rho g)^2 + (\rho r \Omega^2)^2 \right]^{1/2}}$$

$$\tan \theta = \frac{dz}{dr} = -\frac{g}{r \Omega^2} \quad \text{slope of } \hat{s}$$

$$-\frac{\Omega^2}{g} dz = \frac{dr}{r} \rightarrow -\frac{\Omega^2 z}{g} = \ln r$$

i.e.,  $r = C_1 \exp\left(-\frac{\Omega^2 z}{g}\right)$  equation of  $\nabla p$  surfaces

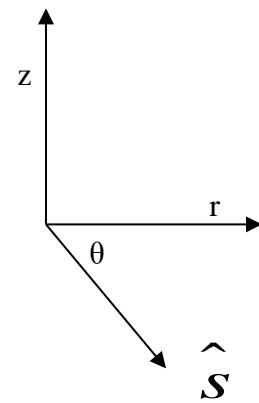

The position of the free surface is found, as it is for linear acceleration, by conserving the volume of fluid.

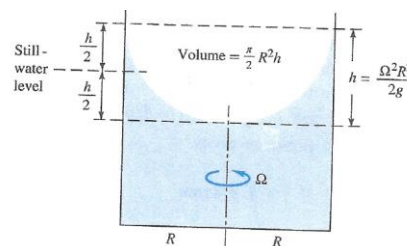

Fig. 2.23 Determining the free-surface position for rotation of a cylinder of fluid about its central axis.

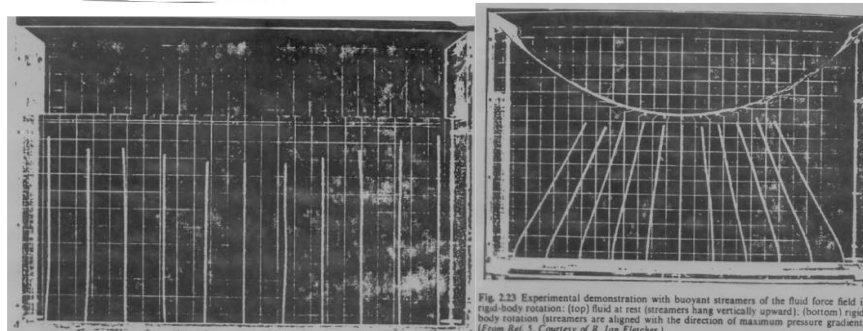

Fig. 2.23 Experimental demonstration with buoyant streamers of the fluid force field in rigid-body rotation: (top) fluid at rest (streamers hang vertically upward), (bottom) rigid-body rotation (streamers are aligned with the direction of maximum pressure gradient). [From Ref. 5. Courtesy of R. Ian Fletcher.]

## **Case (3) Pressure Distribution in Irrotational Flow; Bernoulli Equation**

Navier-Stokes for constant property incompressible flow:

$$\rho \underline{a} = -\nabla(p) - \rho g \hat{k} + \mu \nabla^2 \underline{V} = -\nabla(p + \gamma z) + \mu \nabla^2 \underline{V}$$

$$\rho \left[ \frac{\partial \underline{V}}{\partial t} + \underline{V} \cdot \nabla \underline{V} \right] = -\nabla(p + \gamma z) + \mu [\nabla(\nabla \cdot \underline{V}) - \nabla \times (\nabla \times \underline{V})]$$

Viscous term=0 for  $\rho$ =constant and  $\underline{\omega}$ =0, i.e., potential flow solutions also solutions NS under such conditions! But cannot satisfy no slip condition and suffers from D'Alembert's paradox that drag = 0.



In fluid dynamics, d'Alembert's paradox (or the hydrodynamic paradox) is a contradiction reached in 1752 by French mathematician Jean le Rond d'Alembert. D'Alembert proved that – for incompressible and inviscid potential flow – the drag force is zero on a body moving with constant velocity relative to the fluid. Zero drag is in direct contradiction to the observation of substantial drag on bodies moving relative to fluids, such as air and water, especially at high velocities corresponding with high Reynolds numbers. It is a particular example of the reversibility paradox.

1. Additionally, assuming inviscid flow:  $\mu=0$  and using vector identity

$$\underline{V} \cdot \nabla \underline{V} = \frac{1}{2} \nabla \underline{V} \cdot \underline{V} - \underline{V} \times (\nabla \times \underline{V})$$

$$\rho \left[ \frac{\partial \underline{V}}{\partial t} + \left( \frac{1}{2} \nabla \underline{V} \cdot \underline{V} - \underline{V} \times (\nabla \times \underline{V}) \right) \right] = -\nabla(p + \gamma z) \text{ Euler Equation}$$

$$\frac{\partial \underline{V}}{\partial t} + \nabla \left[ \frac{V^2}{2} + \frac{p}{\rho} + gz \right] = \underline{V} \times \underline{\omega} \quad V^2 = \underline{V} \cdot \underline{V} \quad (\underline{\omega} \neq 0)$$



2. Additionally, assuming steady flow:  $\frac{\partial}{\partial t} = 0$

$$\nabla B = \underline{V} \times \underline{\omega}$$

$$B = \frac{V^2}{2} + \frac{p}{\rho} + gz$$

Consider:

$\nabla B$  perpendicular  $B = \text{constant}$

$\underline{V} \times \underline{\omega} = \nabla B$  perpendicular  $\underline{V}$  and  $\underline{\omega}$

Therefore,  $B = \text{constant}$  contains streamlines and vortex lines:

$$\hat{e}_s \cdot \nabla B = \frac{\partial B}{\partial s} = 0$$

$$\hat{e}_v \cdot \nabla B = 0$$

$$B = \frac{V^2}{2} + \frac{p}{\rho} + gz = \text{constant along streamlines}$$

and vortex lines.

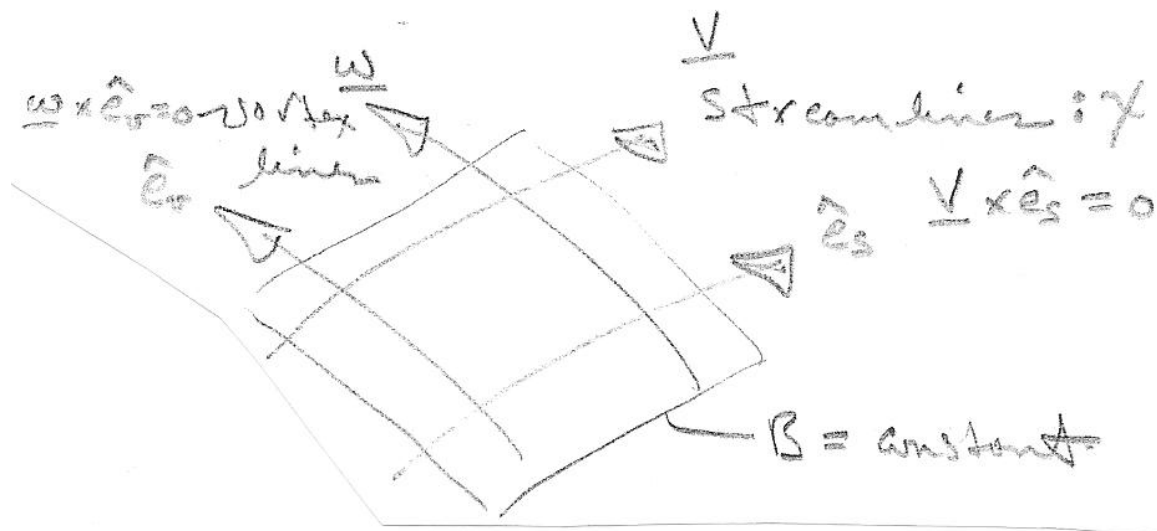

3. Additionally assuming irrotational flow:  $\underline{\omega}=0$

$\nabla B = 0$   $B = \text{constant}$  (everywhere same constant)

$$\frac{V^2}{2} + \frac{p}{\rho} + gz = B$$

4. Unsteady, inviscid, incompressible, and irrotational flow:  
 $\underline{\mu}=0$ ,  $\rho = \text{constant}$ ,  $\underline{\omega}=0$ , i.e., potential flow

$$\underline{V} = \nabla \phi$$

$$V^2 = \nabla \phi \cdot \nabla \phi$$

$$\nabla \left[ \frac{\partial \phi}{\partial t} + \frac{\nabla \phi \cdot \nabla \phi}{2} + \frac{p}{\rho} + gz \right] = 0$$

$$\frac{\partial \phi}{\partial t} + \frac{\nabla \phi \cdot \nabla \phi}{2} + \frac{p}{\rho} + gz = B(t)$$

$B(t) = \text{time dependent constant}$

### Alternate derivation using stream line coordinates:

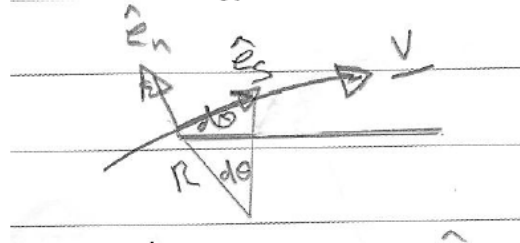

$R$  = local radius of curvature along streamline

$$\underline{V} = v_s(s,t)\hat{e}_s + v_n\hat{e}_n = v_s(s,t)\hat{e}_s$$

$$\nabla = \hat{e}_s \frac{\partial}{\partial s} + \hat{e}_n \frac{\partial}{\partial n}$$

$$\underline{a} = \frac{D\underline{V}}{Dt} = \frac{\partial \underline{V}}{\partial t} + \underline{V} \cdot \nabla \underline{V} = \frac{\partial \underline{V}}{\partial t} + v_s \frac{\partial \underline{V}}{\partial s} = \left[ \frac{\partial v_s}{\partial t} \hat{e}_s + v_s \frac{\partial \hat{e}_s}{\partial t} \right] + v_s \left[ \frac{\partial v_s}{\partial s} \hat{e}_s + v_s \frac{\partial \hat{e}_s}{\partial s} \right]$$

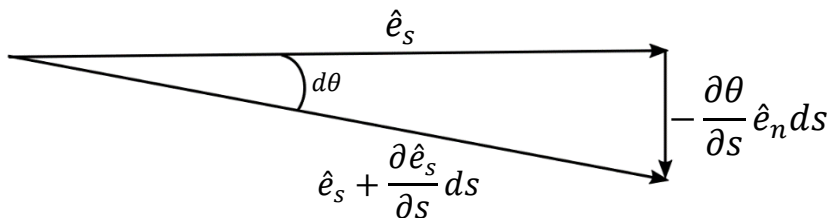

To 1<sup>st</sup> order  $\hat{e}_s$  changes by  $\frac{\partial \hat{e}_s}{\partial s}$  along  $\psi$  for increments  $ds = R d\theta$

In a space increment  $ds$ , the tangent unit vector  $\hat{e}_s$  is transformed into  $\hat{e}_s + \frac{\partial \hat{e}_s}{\partial s} ds$  and its direction changes by  $d\theta$ . The vector connecting the two can be obtained using the triangle rule, and its magnitude is equal to  $d\theta$ , pointing in the  $-\hat{e}_n$  direction. Alternatively, this can be written as:  $-\frac{\partial \theta}{\partial s} \hat{e}_n ds$ .

Therefore:

$$\hat{e}_s + \frac{\partial \hat{e}_s}{\partial s} ds = \hat{e}_s - \frac{\partial \theta}{\partial s} \hat{e}_n ds$$

i.e.,

$$\frac{\partial \hat{e}_s}{\partial s} = -\frac{\partial \theta}{\partial s} \hat{e}_n = -\frac{1}{R} \hat{e}_n$$

$$\frac{\partial \theta}{\partial s} = \frac{1}{R}$$

Where  $\frac{\partial \theta}{\partial s}$  represents the curvature  $k$  of the trajectory, or equivalently  $1/R$ .

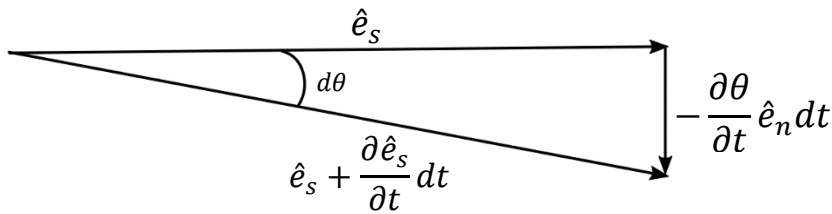

Similarly, in a time increment  $dt$ , the tangent unit vector  $\hat{e}_s$  is transformed into  $\hat{e}_s + \frac{\partial \hat{e}_s}{\partial t} dt$  and its direction changes by  $d\theta$ . The vector connecting the two can be obtained using the triangle rule, and its magnitude is equal to  $d\theta$ , pointing in the  $-\hat{e}_n$  direction. Alternatively, this can be written as:  $-\frac{\partial \theta}{\partial t} \hat{e}_n dt$ .

Therefore:

$$\hat{e}_s + \frac{\partial \hat{e}_s}{\partial t} dt = \hat{e}_s - \frac{\partial \theta}{\partial t} \hat{e}_n dt$$

i.e.,

$$\frac{\partial \hat{e}_s}{\partial t} = -\frac{\partial \theta}{\partial t} \hat{e}_n$$

Consequently, the acceleration vector can be expressed as:

$$\underline{a} = \left[ \frac{\partial v_s}{\partial t} + v_s \frac{\partial v_s}{\partial s} \right] \hat{e}_s + \left[ -v_s \frac{\partial \theta}{\partial t} - \frac{v_s^2}{R} \right] \hat{e}_n$$

$$\frac{\partial v_s}{\partial t} = \text{local } a_s \text{ in direction of flow}$$

$$\frac{\partial v_n}{\partial t} = -v_s \frac{\partial \theta}{\partial t} = \text{local } a_n \text{ normal to flow}$$

$v_s \frac{\partial v_s}{\partial s}$  = convective  $a_s$  due to convergence/divergence of streamlines

$$-\frac{v_s^2}{R} = \text{normal } a_n \text{ due to streamline curvature}$$

## Euler Equation

$$\rho \underline{a} = -\nabla(p + \gamma z)$$

Steady flow s equation:

$$\rho v_s \frac{\partial v_s}{\partial s} = -\frac{\partial}{\partial s}(p + \gamma z)$$

$$\frac{\partial}{\partial s} \left( \frac{v_s^2}{2} + \frac{p}{\rho} + gz \right) = 0$$

i.e., B=constant along streamline

Steady flow n equation:

$$-\rho \frac{\partial v_s^2}{R} = -\frac{\partial}{\partial n}(p + \gamma z)$$

$$-\int \frac{v_s^2}{R} dn + \frac{p}{\rho} + gz = \text{constant across streamline}$$

Larger speed/density or smaller R require larger pressure gradient or elevation gradient normal to streamline.

Highlights that the Bernoulli equation can also be obtained by integration of the Euler equation along a streamline.

## Flow Patterns: Streamlines, Streaklines, Pathlines

- 1) A streamline is a line everywhere tangent to the velocity vector at a given instant.
- 2) A pathline is the actual path traveled by a given fluid particle.
- 3) A streakline is the locus of particles which have earlier passed through a particular point.

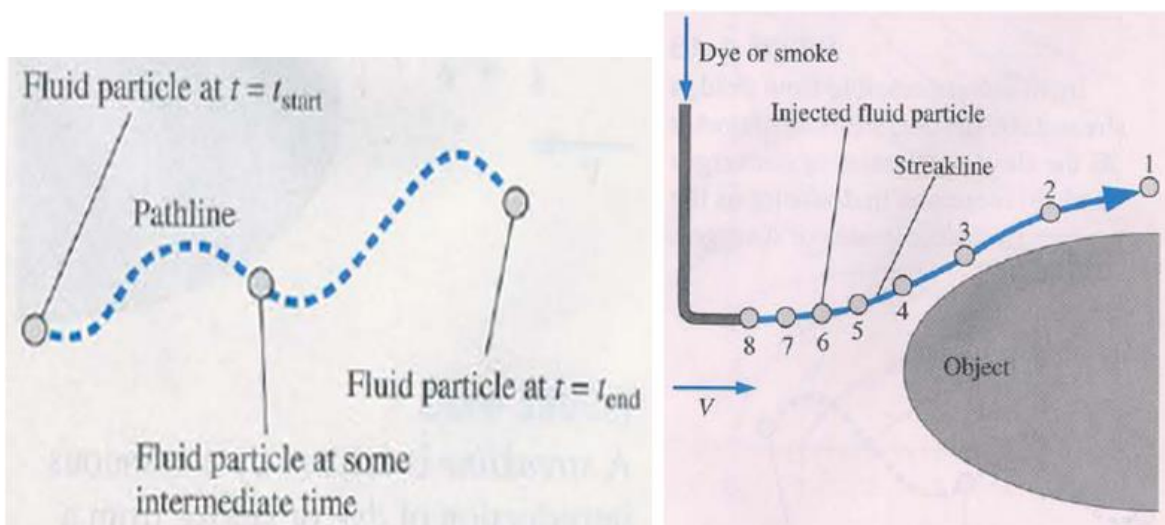

Note:

1. For steady flow, all 3 coincide.
2. For unsteady flow,  $\psi(t)$  pattern changes with time, whereas pathlines and streaklines are generated as the passage of time.

## Streamline

By definition along a streamline  $\underline{V} \times \underline{dr} = 0$  which upon expansion yields the equation of the streamlines for a given time  $t = t_1$

$$\frac{dx}{u} = \frac{dy}{v} = \frac{dz}{w} = ds \quad s = \text{integration parameter}$$

So if  $(u,v,w)$  known, integrate with respect to  $s$  for  $t=t_1$  with IC  $(x_0,y_0,z_0,t_1)$  at  $s=0$  and then eliminate  $s$ .

## Pathline

The pathline is defined by integration of the relationship between velocity and displacement.

$$\frac{dx}{dt} = u \quad \frac{dy}{dt} = v \quad \frac{dz}{dt} = w$$

Integrate  $u,v,w$  with respect to  $t$  using IC  $(x_0,y_0,z_0,t_0)$  then eliminate  $t$ .

## Streakline

To find the streakline, use the integrated result for the pathline retaining time as a parameter. Now, find the integration constant which causes the pathline to pass through  $(x_0,y_0,z_0)$  for a sequence of times  $\xi < t$ . Then eliminate  $\xi$ .

## The Stream Function

Powerful tool for 2-D flow in which  $\underline{V}$  is obtained by differentiation of a scalar  $\psi$  which automatically satisfies the continuity equation.

Note for 2D flow

$$\nabla \times V = \left( \frac{\partial w}{\partial y} - \frac{\partial v}{\partial z}, \frac{\partial u}{\partial z} - \frac{\partial w}{\partial x}, \frac{\partial v}{\partial x} - \frac{\partial u}{\partial y} \right) = (0, 0, \omega_z)$$

Continuity:  $u_x + v_y = 0$

say:  $u = \psi_y$  and  $v = -\psi_x$

then:  $\frac{\partial}{\partial x}(\psi_y) + \frac{\partial}{\partial y}(-\psi_x) = \psi_{yx} - \psi_{xy} = 0$  by definition!

$$\underline{V} = \psi_y \hat{i} - \psi_x \hat{j}$$

$$\text{curl } \underline{V} = \hat{k} \omega_z = -\hat{k} \nabla^2 \psi \quad (\omega_z = v_x - u_y = -\psi_{xx} - \psi_{yy} = -\nabla^2 \psi)$$

NS equation for unsteady constant property flow:

$$\rho \frac{\partial \underline{V}}{\partial t} + \rho (\underline{V} \cdot \nabla) \underline{V} = -\nabla(p + \gamma z) + \mu \nabla^2 \underline{V}$$

Taking the curl gives:

$$\rho \left( \nabla \times \frac{\partial \underline{V}}{\partial t} \right) + \rho \nabla \times (\underline{V} \cdot \nabla) \underline{V} = \mu \nabla^2 (\nabla \times \underline{V}) \quad (1)$$

For the unsteady term:

$$\rho \left( \nabla \times \frac{\partial \underline{V}}{\partial t} \right) = \rho \frac{\partial}{\partial t} (\nabla \times \underline{V}) = \rho \frac{\partial \omega}{\partial t}$$



Recall vector identity:

$$\underline{V} \times (\nabla \times \underline{V}) = \frac{1}{2} \nabla(V^2) - (\underline{V} \cdot \nabla) \underline{V}$$

Such that:

$$(\underline{V} \cdot \nabla) \underline{V} = \frac{1}{2} \nabla(V^2) - \underline{V} \times (\nabla \times \underline{V}) \quad (2)$$

Taking the curl of (2), recalling that the curl of the gradient of a scalar equals zero and using  $\nabla \times \underline{V} = \underline{\omega}$ , gives:

$$\nabla \times \{(\underline{V} \cdot \nabla) \underline{V}\} = -\nabla \times (\underline{V} \times \underline{\omega}) = \nabla \times (\underline{\omega} \times \underline{V}) \quad (3)$$

And using Eq. (3) into Eq. (1) gives:

$$\rho \frac{\partial \underline{\omega}}{\partial t} + \rho \nabla \times (\underline{\omega} \times \underline{V}) = \mu \nabla^2 \underline{\omega} \quad (4)$$

Recall vector identity:

$$\nabla \times (\underline{a} \times \underline{b}) = \underline{a}(\nabla \cdot \underline{b}) + (\underline{b} \cdot \nabla) \underline{a} - \underline{b}(\nabla \cdot \underline{a}) - (\underline{a} \cdot \nabla) \underline{b}$$

Such that:

$$\nabla \times (\underline{\omega} \times \underline{V}) = \underline{\omega}(\nabla \cdot \underline{V}) + (\underline{V} \cdot \nabla) \underline{\omega} - \underline{V}(\nabla \cdot \underline{\omega}) - (\underline{\omega} \cdot \nabla) \underline{V}$$

And Eq. (4) becomes (vorticity transport equation):

$$\rho \frac{\partial \underline{\omega}}{\partial t} + \rho [(\underline{V} \cdot \nabla) \underline{\omega} - (\underline{\omega} \cdot \nabla) \underline{V}] = \mu \nabla^2 \underline{\omega} \quad (4)$$

The second term in brackets in Eq. (4) represents vortex stretching and it is exactly zero for 2D flow, since the velocity and vorticity vector are orthogonal, i.e.,  $\underline{\omega} \cdot \nabla = \omega_z \frac{\partial}{\partial z} = 0$ .

The resulting equation is (2D vorticity transport equation):

$$\rho \frac{\partial \underline{\omega}}{\partial t} + \rho [(\underline{V} \cdot \nabla) \underline{\omega}] = \mu \nabla^2 \underline{\omega} \quad (5)$$

Recall:

$$u = \psi_y \quad v = \psi_x$$

$$\underline{\omega} = \nabla \times \underline{V} = \hat{k} \omega_z = -\hat{k} \nabla^2 \psi$$

Such that Eq. (5) becomes:

$$\rho \frac{\partial (-\hat{k} \nabla^2 \psi)}{\partial t} + \rho [(\underline{V} \cdot \nabla) (-\hat{k} \nabla^2 \psi)] = \mu \nabla^2 (-\hat{k} \nabla^2 \psi)$$

And writing  $(\underline{V} \cdot \nabla)$  by components gives:

$$\rho \frac{\partial (-\hat{k} \nabla^2 \psi)}{\partial t} + \rho \left[ \left( u \frac{\partial}{\partial x} + v \frac{\partial}{\partial y} \right) (-\hat{k} \nabla^2 \psi) \right] = \mu \nabla^2 (-\hat{k} \nabla^2 \psi) \quad (6)$$

Substituting the definition of stream function in Eq. (6) for u and v gives:

$$\frac{\partial \nabla^2 \psi}{\partial t} + \left[ \frac{\partial \psi}{\partial y} \frac{\partial}{\partial x} (\nabla^2 \psi) - \frac{\partial \psi}{\partial x} \frac{\partial}{\partial y} (\nabla^2 \psi) \right] = \nu \nabla^4 \psi$$

This represents a single scalar equation, but 4<sup>th</sup> order!

boundary conditions (4 required):

at infinity :  $u = \psi_y = U_\infty \quad v = -\psi_x = 0$

on body :  $u = v = 0 = \psi_y = -\psi_x$

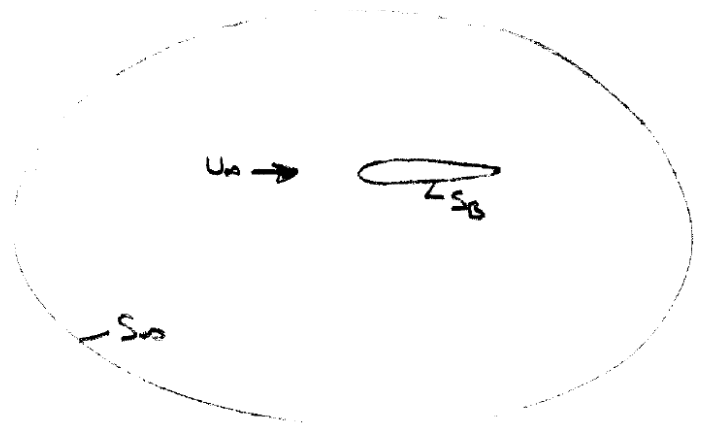

## Irrotational Flow

$$\nabla^2 \psi = 0 \quad \text{2nd order linear Laplace equation}$$

$$\text{on } S_\infty : \quad \psi = U_\infty y + \text{const.}$$

$$\text{on } S_B : \quad \psi = \text{const.}$$

$$u = \psi_y = \phi_x$$

$$v = -\psi_x = \phi_y$$

$\Psi$  and  $\phi$  are orthogonal.

$$d\phi = \phi_x dx + \phi_y dy = u dx + v dy$$

$$d\psi = \psi_x dx + \psi_y dy = -v dx + u dy$$

$$\text{i.e. } \left. \frac{dy}{dx} \right|_{\phi = \text{const}} = -\frac{u}{v} = \frac{-1}{\left. \frac{dy}{dx} \right|_{\psi = \text{const}}}$$

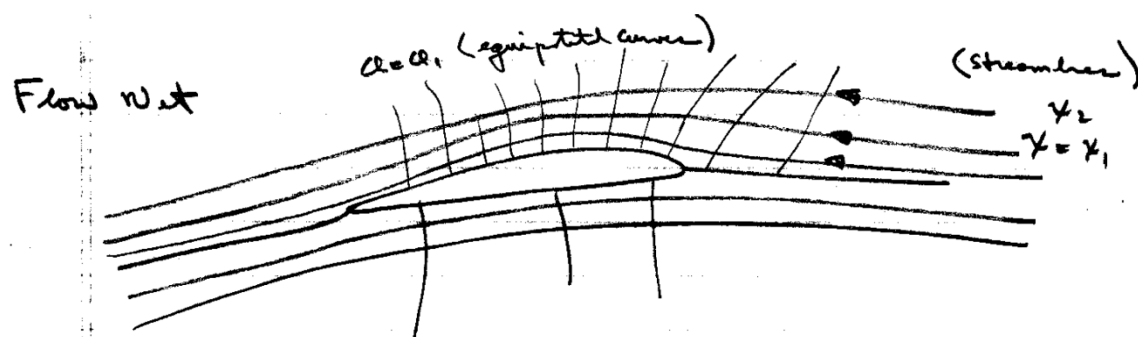

## Geometric Interpretation of $\psi$

Besides its importance mathematically  $\psi$  also has important geometric significance.

$\psi = \text{constant} = \text{streamline}$

Recall definition of a streamline:

$$\nabla \times \underline{dr} = 0 \quad \underline{dr} = dx\hat{i} + dy\hat{j}$$

$$\frac{dx}{u} = \frac{dy}{v}$$

$$udy - vdx = 0$$

$$\text{compare with } d\psi = \psi_x dx + \psi_y dy = -vdx + udy$$

i.e.  $d\psi = 0$  along a streamline

Or  $\psi = \text{constant}$  along a streamline and curves of constant  $\psi$  are the flow streamlines. If we know  $\psi(x, y)$  then we can plot  $\psi = \text{constant}$  curves to show streamlines.

## Physical Interpretation

$$dQ = \underline{V} \cdot \underline{n} dA$$

$$= \left( \hat{i} \frac{\partial \psi}{\partial y} - \hat{j} \frac{\partial \psi}{\partial x} \right) \cdot \left( \frac{dy}{ds} \hat{i} - \frac{dx}{ds} \hat{j} \right) \times ds \times 1$$

$$= \psi_y dy + \psi_x dx$$

$$= d\psi$$

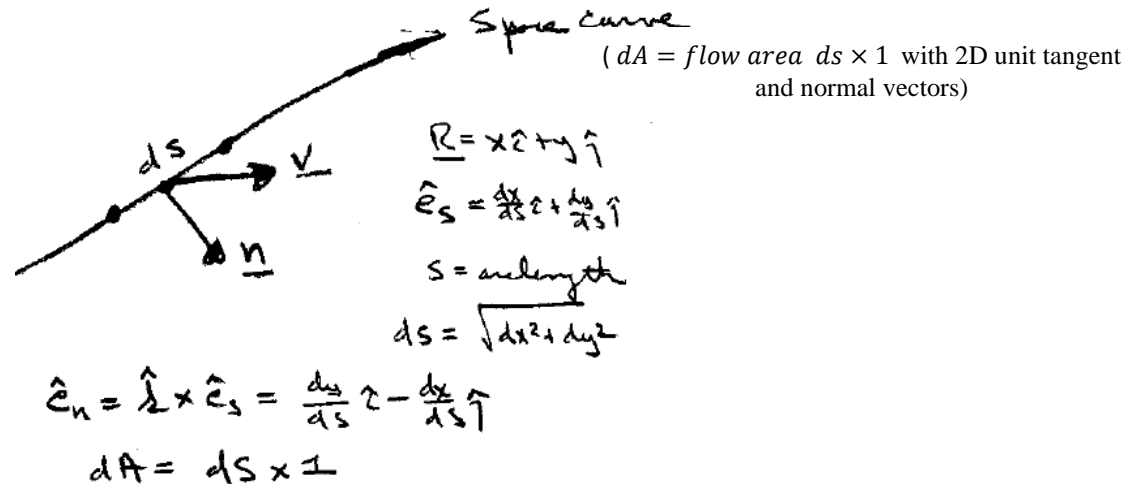

i.e., change in  $d\psi$  is volume flux and across streamline  $dQ = 0$ .

$$Q_{1 \rightarrow 2} = \int_1^2 \underline{V} \cdot \underline{n} dA = \int_1^2 d\psi = \psi_2 - \psi_1$$

Consider flow between two streamlines:  $u = \frac{\partial \psi}{\partial y}$ ,  $v = -\frac{\partial \psi}{\partial x}$

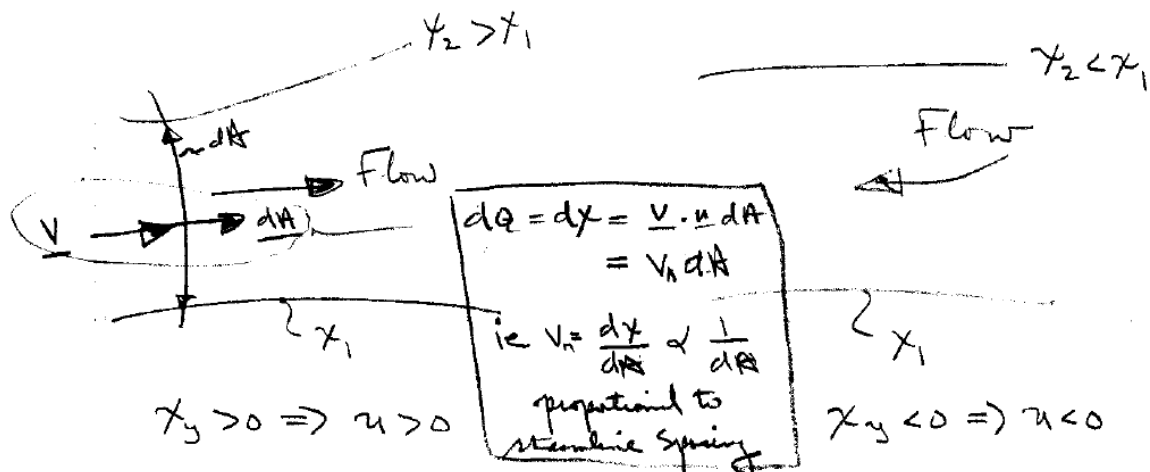

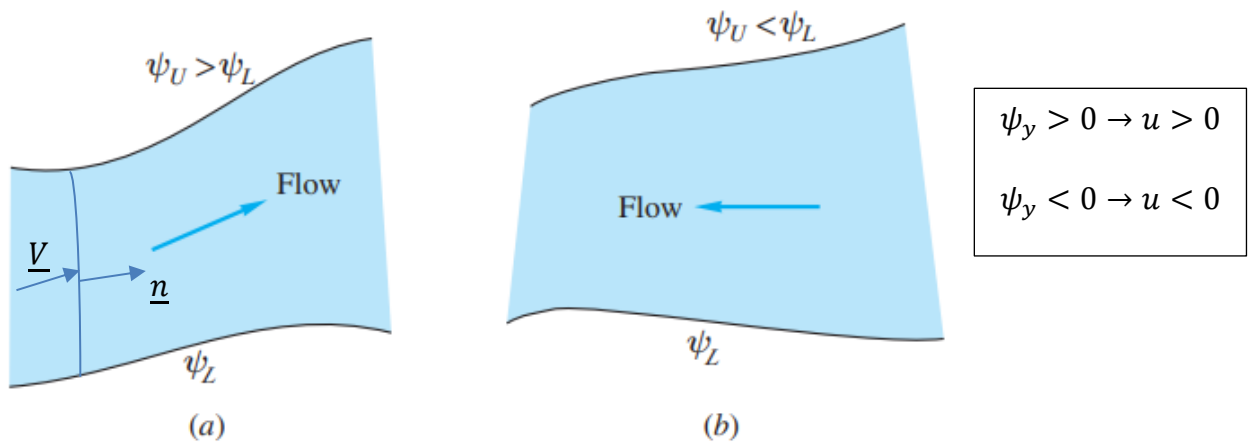

$$dQ = d\psi = \underline{V} \cdot \underline{n} dA = V_n dA$$

$$V_n = \frac{d\psi}{dA} \propto \frac{1}{dA}$$

i.e., proportional to streamline spacing.

## Incompressible Plane Flow in Polar Coordinates

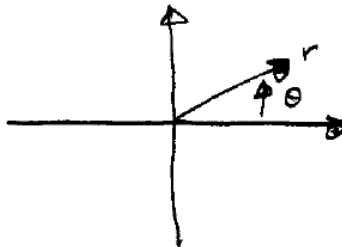

continuity:  $\frac{1}{r} \frac{\partial}{\partial r} (r v_r) + \frac{1}{r} \frac{\partial}{\partial \theta} (v_\theta) = 0$

or:  $\frac{\partial}{\partial r} (r v_r) + \frac{\partial}{\partial \theta} (v_\theta) = 0$

say:  $v_r = \frac{1}{r} \frac{\partial \psi}{\partial \theta} \quad v_\theta = -\frac{\partial \psi}{\partial r}$

then  $\frac{\partial}{\partial r} \left( r \frac{1}{r} \frac{\partial \psi}{\partial \theta} \right) + \frac{\partial}{\partial \theta} \left( -\frac{\partial \psi}{\partial r} \right) = 0$

as before  $d\psi = 0$  along a streamline and  $dQ = d\psi$

volume flux = change in stream function

## Incompressible axisymmetric flow

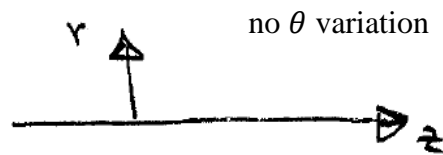

$$\text{continuity : } \frac{1}{r} \frac{\partial}{\partial r} \left( r v_r \right) + \frac{\partial}{\partial z} \left( v_z \right) = 0$$

$$\text{say : } v_r = -\frac{1}{r} \frac{\partial \psi}{\partial z} \quad v_z = \frac{1}{r} \frac{\partial \psi}{\partial r}$$

$$\text{then : } \frac{1}{r} \frac{\partial}{\partial r} \left( r \frac{-1}{r} \frac{\partial \psi}{\partial z} \right) + \frac{\partial}{\partial z} \left( \frac{1}{r} \frac{\partial \psi}{\partial r} \right) = 0$$

as before  $d\psi = 0$  along a streamline and  $dQ = d\psi$

## Generalization

Steady plane compressible flow:

$$\frac{\partial}{\partial x}(\rho u) + \frac{\partial}{\partial y}(\rho v) = 0$$

$$\text{define: } \rho u = \frac{\partial \psi}{\partial y} \quad \rho v = -\frac{\partial \psi}{\partial x}$$

$\psi$  = compressible flow stream function

$u dy - v dx = 0$  definition streamline

$$\frac{1}{\rho} \psi_y dy + \frac{1}{\rho} \psi_x dx = 0$$

$$d\psi = \psi_x dx + \psi_y dy \Rightarrow \frac{1}{\rho} (d\psi) = 0 \quad \text{i.e.}$$

$d\psi = 0$  and  $\psi = \text{constant}$  is a streamline

The change in  $\psi$  is now equal to the mass flow rate:

$$d\dot{m} = \rho(\underline{V} \cdot \underline{n}) dA = d\psi$$

$$\dot{m}_{1 \rightarrow 2} = \int_1^2 \rho(\underline{V} \cdot \underline{n}) dA = \psi_2 - \psi_1$$