

ME:5160
Intermediate Mechanics of Fluids

Class Notes
Fall 2023

Prepared by:
Professor Fred Stern

Typed by:
Derek Schnabel (Fall 2004)
Nobuaki Sakamoto (Fall 2006)
Hamid Sadat-Hosseini (Fall 2006)
Maysam Mousaviraad (Fall 2006)

Corrected by:
Jun Shao (Fall 2004)
Mani Kandasamy (Fall 2005)
Tao Xing, Hyun Se Yoon (Fall 2006)
Hamid Sadat-Hosseini (Fall 2007-2010)
Maysam Mousaviraad (Fall 2013-2016)
Timur Kent Dogan (Fall 2017-2018)
Sungtek Park (Fall 2019-2021)
Christian Milano (Fall 2022-2023)

Chapter 1: Introduction

Definition of a fluid:

A fluid cannot resist an applied shear stress and remain at rest, whereas a non-fluid (i.e., solid) can.

Solids resist shear by static deformation up to an elastic limit of the material, after which they undergo fracture.

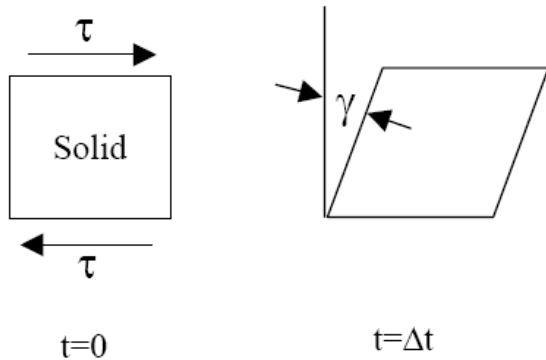

Elastic solid: $\tau \propto \gamma = \text{strain}$
 $\tau = G \gamma$

$G = \text{shear modulus}$

Fluids deform continuously (undergo motion) when subjected to shear stress. Consider a fluid between two parallel plates, with the lower one fixed and the upper moving at speed U , which is an example of Couette flow (i.e., wall/shear driven flows).

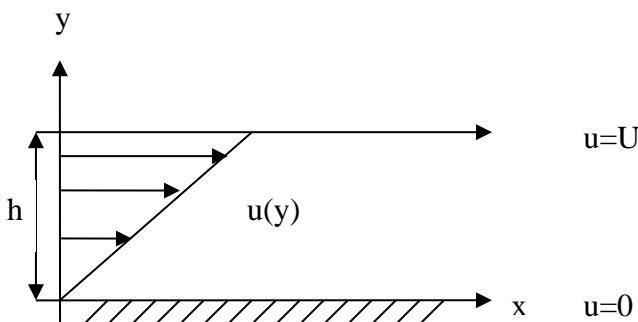

$$\underline{V} = u(y) \hat{i}$$

1-D flow velocity profile: linear

$$\frac{du(y)}{dy} = \frac{U}{h}$$

No slip condition:

Length scale of molecular mean free path $\lambda \ll$ length scale of fluid motion ℓ ; therefore, macroscopically there is no relative motion or temperature between the solid and fluid in contact. **Knudsen number = $K_n = \lambda/\ell \ll 1$.** Exceptions are rarefied gases and gas/liquid contact line.

Newtonian fluids:

$$\tau \propto \dot{\theta} = \text{rate of strain}$$

$$\tau = \mu \dot{\theta}$$

$\mu =$ coefficient of viscosity

Rate of Strain: 1D shear flow $\underline{V} = u(y) \hat{i}$, $u_y = du/dy$, and 1st order Taylor series

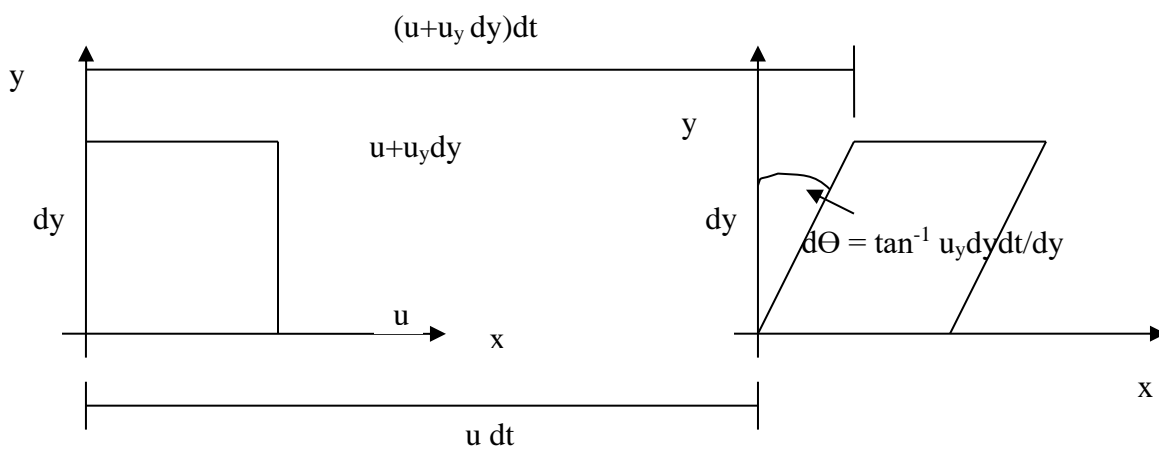

Fluid element with sides parallel to the coordinate axes at time $t=0$.

Fluid element deformation at time $t + dt$

$$\tan d\theta = u_y dy dt / dy \qquad \frac{d\theta}{dt} = \dot{\theta} = u_{y,y}$$

(Rate-of-strain = velocity gradient)

$$\tau = \mu \dot{\theta} = \mu \frac{du}{dy}$$

For 3D flow, rate of strain ε_{ij} and stress σ_{ij} tensors are second order symmetric tensors:

$$\varepsilon_{ij} = \frac{1}{2} \left(\frac{\partial u_i}{\partial x_j} + \frac{\partial u_j}{\partial x_i} \right) = \varepsilon_{ji}$$

$$\underline{V} = u\hat{i} + v\hat{j} + w\hat{k} = u_i = (u, v, w)$$

$$\underline{X} = x\hat{i} + y\hat{j} + z\hat{k} = x_i = (x, y, z)$$

and

$$\sigma_{ij} = - \left(p + \frac{2}{3} \mu \nabla \cdot \underline{V} \right) \delta_{ij} + 2\mu \varepsilon_{ij} = \sigma_{ji}$$

Diagonal terms are elongation/contraction in x,y,z and off diagonal terms are shear in (x,y), (x,z), and (y,z).

Liquids vs. Gases:

Liquids	Gases
Closely spaced with large intermolecular cohesive forces	Widely spaced with small intermolecular cohesive forces
Retain volume but take shape of container	Take volume and shape of container
$\beta \ll 1$ $\rho \sim \text{constant}$	$\beta \gg 1$ $\rho = \rho(p, T)$

Where β = coefficient of compressibility = change in volume/density with external pressure:

$$\beta = -\frac{1}{\nabla} \frac{\partial \nabla}{\partial p} = \frac{1}{\rho} \frac{\partial \rho}{\partial p}$$

Or its inverse which is called bulk modulus:

$$K = -\nabla \frac{\partial p}{\partial \nabla} = \rho \frac{\partial p}{\partial \rho} = \frac{1}{\beta}$$

Liquids: K large, i.e., large Δp only causes small $\Delta \nabla$.

Gases: $K \approx p$ for $T = \text{constant}$, i.e., $p = \rho RT$.

Recall p-v-T diagram from thermodynamics:

Single phase, two phase, triple point (point at which solid, liquid, and vapor are all in equilibrium), critical point (maximum pressure at which liquid and vapor are both in equilibrium).

Liquid, gases, and two-phase liquid-vapor behave as fluids.

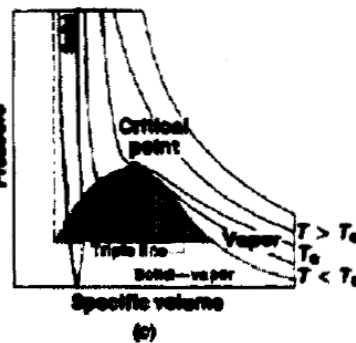
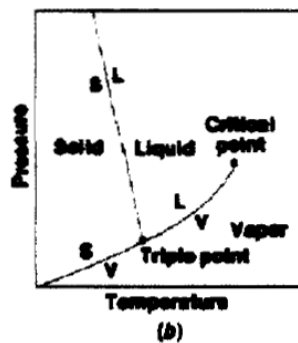
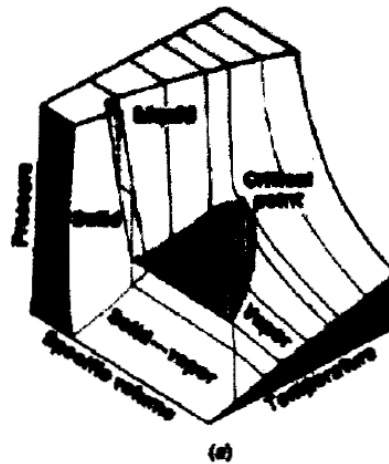

Continuum Hypothesis

Fluids are composed of molecules in constant motion and collision; however, in most cases, molecular motion can be disregarded, and the assumption is made that the fluid behaves as a continuum, i.e., the number of molecules within the smallest region of interest (a point = a fluid particle) are sufficient that all fluid properties are point functions (single valued at a point).

For example:

Consider the definition of the density ρ of a fluid: mass per unit volume, i.e.,

$$\rho(\underline{x}, t) = \lim_{\delta V \rightarrow \delta V^*} \frac{\delta M}{\delta V}$$

\underline{x} = position vector = $x\mathbf{i} + y\mathbf{j} + z\mathbf{k}$
 t = time
 M = mass

δV^* = limiting volume below which molecular variations may be important and above which macroscopic variations may be important.

$\delta V^* \approx 10^{-9} \text{ mm}^3$ for all liquids and for gases at atmospheric pressure.

10^{-9} mm^3 air (at standard conditions, 20°C and 1 atm) contains 3×10^7 molecules such that $\delta M / \delta V = \text{constant} = \rho$.

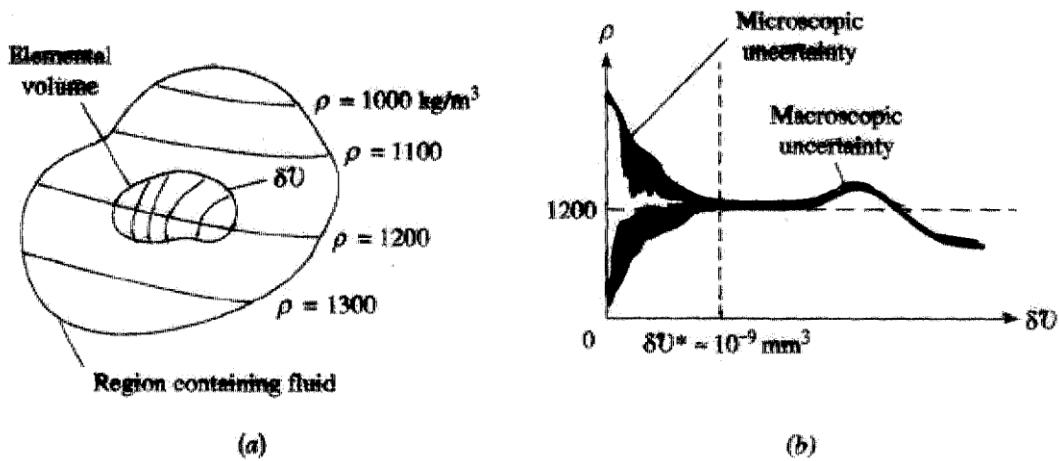

²One atmosphere equals $2116 \text{ lbf/ft}^2 = 101,300 \text{ Pa}$.

Exception: rarefied gas flow.

Note that typical “smallest” measurement volumes are about $5 \mu\text{m}^3$ (LDV) – 1 mm^3 (PIV) $\gg \delta V^*$ and that the “scale” of macroscopic variations are very problem dependent. $17\text{-}181 \mu\text{m}$ – diameter of human hair.

A point in a fluid is equivalently used to define a fluid particle or infinitesimal material element used in defining the governing differential equations of fluid dynamics.

At a more advanced level, the Knudsen number is used to quantify the separation of molecular and fluid motion length scales: $K_n = \lambda/\ell$ where λ = molecular length scale and ℓ = fluid motion length scale.

Molecular scales:

Air atmosphere conditions:

$$\lambda = 6 \times 10^{-8} \text{ m} = \text{mean free path}$$

$$t_\lambda = 10^{-10} \text{ s} = \text{time between collisions}$$

Smallest fluid motion scales:

$$\ell = 0.1 \text{ mm} = 10^{-4} \text{ m}$$

$$U_{\text{max}} \sim 100 \text{ m/s} \quad \text{incompressible flow } M_a \leq 0.3$$

$$t_\ell = 10^{-6} \text{ s}$$

Thus $\text{Kn} \sim 10^{-3} \ll 1$, and ℓ scales larger than 3 order of magnitude λ scales.

An intermediate scale is used to define a fluid particle:

$$\lambda \ll \ell^* \ll \ell$$

And continuum fluid properties are an average over:

$$\forall^* = l^{*3} \cong 10^{-9} \text{ mm}^3 \Rightarrow l^* = 10^{-3} \text{ mm} = 10^{-6} \text{ m}$$

Previously given smallest fluid motion scales are rough estimates for incompressible flow. Estimates are VERY conservative for laminar flow since for laminar flow, l is usually taken as smallest characteristic length of the flow domain and U_{\max} cannot exceed Re restriction imposed by transition from laminar to turbulent flow.

For turbulent flow, the smallest fluid motion scales are estimated by the Kolmogorov scales, which define the length, velocity, and time scales at which viscous dissipation takes place i.e., at which turbulent kinetic energy is destroyed.

$$\eta = (\nu^3 / \varepsilon)^{1/4} \quad \tau_\eta = (\nu / \varepsilon)^{1/2} \quad u_\eta = (\nu \varepsilon)^{1/4}$$

ν = kinematic viscosity

$$\varepsilon = \text{dissipation rate: } \varepsilon = u_0^2 / \tau_0 = u_0^3 / l_0$$

$\tau_0 = l_0 / u_0$ is the “eddy” turnover time.

ε is determined by largest scales but occurs at smallest scales and is independent of ν .

Kolmogorov scales can also be written:

$$\eta \approx l_0 \text{Re}^{-3/4} \qquad l_0 \approx L$$

$$u_\eta \approx u_0 \text{Re}^{-1/4} \qquad \text{Re}_0 = \frac{u_0 l_0}{\nu} \approx \frac{UL}{\nu}$$

$$\tau_\eta = \tau_0 \text{Re}^{-1/2}$$

Which even for large Re of interest $\eta \gg l^*$

For example: 100-watt mixer in 1 kg water:

$$\varepsilon = 100 \text{ watt/kg} = 100 \text{m}^2/\text{s}^2$$

$$\nu = 10^{-6} \text{m}^2/\text{s}^2 \text{ for water}$$

$$\eta = 10^{-2} \text{mm} > l^*$$

The smallest fluid motion scales for ships and airplanes:

	U(m/s)	L(m)	ν (m ² /s)	Re	η (m)	u_η (m/s)	τ_η (s)
Ship (Container: ALIANCA MAUA)	11.8 (23.3 knots)	272	9.76E-7	3.3E09	2E-5	0.05	4E-4
Airplane (Airbus A300)	216.8 (Ma=0.64)	56.2	3.7E-5 (z=10Km)	0.3E09	2.3E-5	1.64	1.4E-5

$$\eta > l^* = 10^{-3} \text{mm} = 10^{-6} \text{m}$$

Fluid Properties:

- (1) **Kinematic**: linear (\underline{V}) and angular ($\underline{\omega}/2$) velocity, rate of strain (ϵ_{ij}), vorticity ($\underline{\omega}$), and acceleration (\underline{a}).
- (2) **Transport**: viscosity (μ), thermal conductivity (k), and mass diffusivity (D).
- (3) **Thermodynamic**: pressure (p), density (ρ), temperature (T), internal energy (\hat{u}), enthalpy ($h = \hat{u} + p/\rho$), entropy (s), specific heat ($C_v, C_p, \gamma = C_p/C_v$, etc).
- (4) **Miscellaneous**: surface tension (σ), vapor pressure (p_v), etc.

(1) *Kinematic Properties:*

Kinematics refers to the description of the flow pattern without consideration of forces and moments, whereas dynamics refers to descriptions of \underline{F} and \underline{M} .

Lagrangian vs. Eulerian description of velocity and acceleration:

- (a) Lagrangian approach focuses on tracking individual fixed particles. Useful but usually not needed and more complex analysis than Eulerian approach.

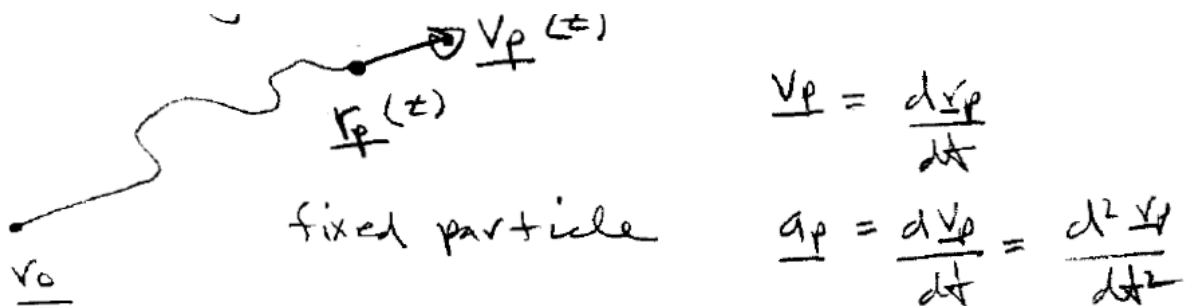

- (b) Eulerian approach focuses on fixed points in space.

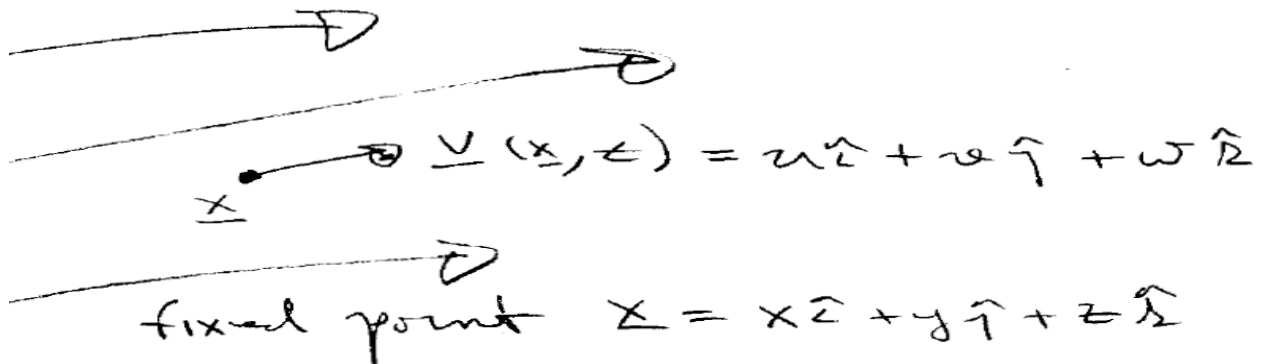

$(u, v, w) = \underline{V}(\underline{x}, t)$ are velocity components in (x, y, z) directions with total derivative:

$$d\underline{V}(\underline{x}, t) = \frac{\partial \underline{V}}{\partial t} dt + \frac{\partial \underline{V}}{\partial x_i} dx_i$$

However, dx_i and dt are not independent since the derivatives are assumed to follow a fluid particle i.e.,

$$dx_i = u_i dt$$

$$\frac{dV(\underline{x}, t)}{dt} = \frac{\partial V}{\partial t} + \frac{\partial V}{\partial x_i} u_i$$

In fluid mechanics special notation is used to define substantial/material derivative, which follows a fluid particle:

$$\frac{DV}{Dt} = \frac{\partial V}{\partial t} + \frac{\partial V}{\partial x} u + \frac{\partial V}{\partial y} v + \frac{\partial V}{\partial z} w$$

$$\frac{DV}{Dt} = \frac{\partial V}{\partial t} + (\underline{V} \cdot \nabla) \underline{V} \quad \text{where } \nabla = \text{gradient} = \frac{\partial}{\partial x} i + \frac{\partial}{\partial y} j + \frac{\partial}{\partial z} k$$

$\frac{D}{Dt} = \frac{\partial}{\partial t} + \underline{V} \cdot \nabla$ = substantial/material derivative = derivative following motion of particle. Often needed/used for other scalar/vector variables.

$$\frac{DV}{Dt} = \text{Lagrangian time rate of change of velocity}$$

$$\frac{\partial \underline{V}}{\partial t} + \underline{V} \cdot \nabla \underline{V} = \text{local \& convective acceleration in terms of Eulerian derivatives}$$

$$\underline{a} = a_x \hat{i} + a_y \hat{j} + a_z \hat{k}$$

$$a_x = \frac{\partial u}{\partial t} + u \frac{\partial u}{\partial x} + v \frac{\partial u}{\partial y} + w \frac{\partial u}{\partial z}$$

$$a_y = \frac{\partial v}{\partial t} + u \frac{\partial v}{\partial x} + v \frac{\partial v}{\partial y} + w \frac{\partial v}{\partial z}$$

$$a_z = \frac{\partial w}{\partial t} + u \frac{\partial w}{\partial x} + v \frac{\partial w}{\partial y} + w \frac{\partial w}{\partial z}$$

Note: vector identity $\underline{V} \cdot \nabla \underline{V} = \nabla \frac{V^2}{2} - \underline{V} \times (\nabla \times \underline{V})$, i.e., for irrotational flow $\underline{\omega} = \nabla \times \underline{V} = 0$ and convective acceleration becomes familiar KE term in the Bernoulli equation.

The Eulerian approach is more convenient since we are seldom interested in simultaneous time history of many individual fluid particles, but rather time history of fluid motion (and \underline{F} , \underline{M}) in fixed regions in space (control volumes). However, three fundamental laws of fluid mechanics (i.e., conservation of mass, momentum, and energy) are formulated for systems (i.e., fluid particles) and not control volumes (i.e., regions) and therefore must be converted from system to CV: Reynolds Transport Theorem. The material derivative is analogous to RTT, as it relates Lagrangian to Eulerian derivatives.

$\underline{V}(\underline{x},t)$ is a vector field. Vector operator's *divergence* and *curl* lead to other kinematics properties:

$$\text{Divergence } (\underline{V}) = \nabla \cdot \underline{V} = \frac{\partial u}{\partial x} + \frac{\partial v}{\partial y} + \frac{\partial w}{\partial z}$$

$$\left. \begin{aligned} M &= \rho \nabla \quad (\nabla = \text{volume of fluid particle}) \\ dM &= \rho d\nabla + \nabla d\rho = 0 \\ -\frac{d\nabla}{\nabla} &= \frac{d\rho}{\rho} \end{aligned} \right\} \Rightarrow \frac{1}{\rho} \frac{D\rho}{Dt} = -\frac{1}{\nabla} \frac{D\nabla}{Dt} \quad (1)$$

$$\text{Continuity: } \frac{D\rho}{Dt} + \rho \nabla \cdot \underline{V} = 0 \Rightarrow \nabla \cdot \underline{V} = -\frac{1}{\rho} \frac{D\rho}{Dt} \quad (2)$$

$$(1) \text{ and } (2): \frac{1}{\nabla} \frac{D\nabla}{Dt} = \nabla \cdot \underline{V} = -\frac{1}{\rho} \frac{D\rho}{Dt}$$

rate of change ∇ per unit ∇ = - rate of change ρ per unit ρ

For incompressible fluids, $\rho = \text{constant}$

$\nabla \cdot \underline{V} = 0$ i.e., fluid particles have constant ∇ , but not necessarily shape.

$$\nabla \times \underline{V} = \text{curl } \underline{V} = \underline{\omega} = \omega_x \hat{i} + \omega_y \hat{j} + \omega_z \hat{k}$$

= vorticity = 2 * angular velocity of fluid particle

$$= \begin{vmatrix} \hat{i} & \hat{j} & \hat{k} \\ \frac{\partial}{\partial x} & \frac{\partial}{\partial y} & \frac{\partial}{\partial z} \\ u & v & w \end{vmatrix}$$

$$= \left(\frac{\partial w}{\partial y} - \frac{\partial v}{\partial z} \right) \hat{i} - \left(\frac{\partial w}{\partial x} - \frac{\partial u}{\partial z} \right) \hat{j} + \left(\frac{\partial v}{\partial x} - \frac{\partial u}{\partial y} \right) \hat{k}$$

For irrotational flow $\nabla \times \underline{V} = 0$

$$\text{i.e., } \underline{V} = \nabla \phi = u \hat{i} + v \hat{j} + w \hat{k} = \frac{\partial \phi}{\partial x} \hat{i} + \frac{\partial \phi}{\partial y} \hat{j} + \frac{\partial \phi}{\partial z} \hat{k}$$

and for $\rho = \text{constant}$,

$$\nabla \cdot \underline{V} = \nabla \cdot \nabla \phi = \nabla^2 \phi = 0 \rightarrow \text{Potential Flow Theory:}$$

Chapter 8

Other useful kinematic properties include volume and mass flowrate (Q, \dot{m}), average velocity (\bar{V}), and circulation (Γ)

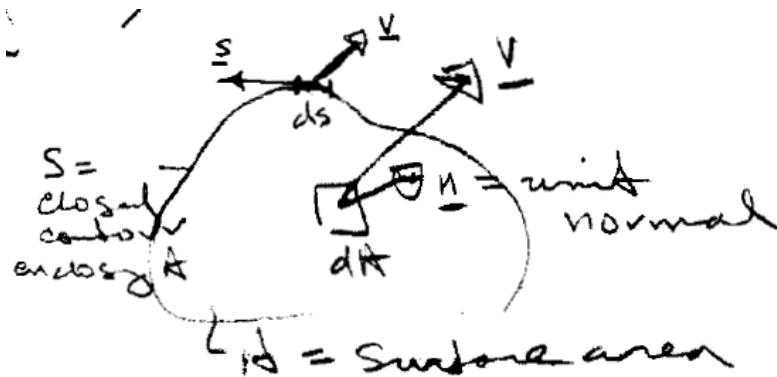

$$\underline{V} \cdot \underline{s} = \text{velocity tangent } s$$

$$\underline{V} \cdot \underline{n} = \text{velocity normal } A$$

$Q = \int_A \underline{V} \cdot \underline{n} \, dA$ where Q = volume of fluid per unit time flowing through A (i.e., flux of V_n through A bounded by S . “flux” generally used to mean surface integral of variable).

$$\dot{m} = \int_A \rho \underline{V} \cdot \underline{n} \, dA$$

where \dot{m} = mass of fluid per unit time through A

$$\bar{V} = Q/A$$

where \bar{V} = average velocity through A

$$A = \int_A dA$$

where A = surface area

$$\Gamma = \oint_S \underline{V} \cdot \underline{ds} = \int_A \nabla \times \underline{V} \cdot \underline{dA} \quad (\text{Stokes's theorem - relates line and area integrals})$$

line integral for tangential

$$\begin{aligned} \text{velocity component} &= \int_A \underline{\omega} \cdot \underline{n} \, dA \\ &= \text{flux (surface integral) of} \\ &\quad \text{normal vorticity} \\ &\quad \text{component} \end{aligned}$$

Kutta-Joukowski Theorem: lift (L) per unit span for an arbitrary 2D cylinder in uniform stream U with density ρ is $L = \rho U \Gamma$, with direction of L perpendicular to U.

(2) *Transport Properties*

There is a close analogy between momentum, heat, and mass transport; therefore, coefficient of viscosity (μ), thermal conductivity (k), and mass diffusivity (D) are referred to as transport properties.

Heat Flux:

$$\text{Fourier's Law:} \quad \underline{q} = -k\nabla T \left[\frac{J}{m^2 s} \right]$$

(Rate of heat flux is proportional to the temperature gradient per unit area; flux is from higher to lower T)

$$\begin{aligned} k \left[\frac{W}{mK} \right] &= f(x,y,z) && \rightarrow \text{solid} \\ &= \text{constant} && \rightarrow \text{liquid \{isotropic\}} \end{aligned}$$

Mass Flux:

Fick's Law:
$$\underline{q} = -D\nabla C \left[\frac{kg}{m^2s} \right]$$

(Rate of mass flux is proportional to concentration (C) gradient per unit area; flux is from higher to lower C)

$$D \left[\frac{m^2}{s} \right]$$

FIGURE 1.2 Mass flux J_m due to variation in the mass fraction $Y(y)$. Here the mass fraction profile increases with increasing y , so Fick's law of diffusion states that the diffusive mass flux that acts to smooth out mass-fraction differences is downward across AB.

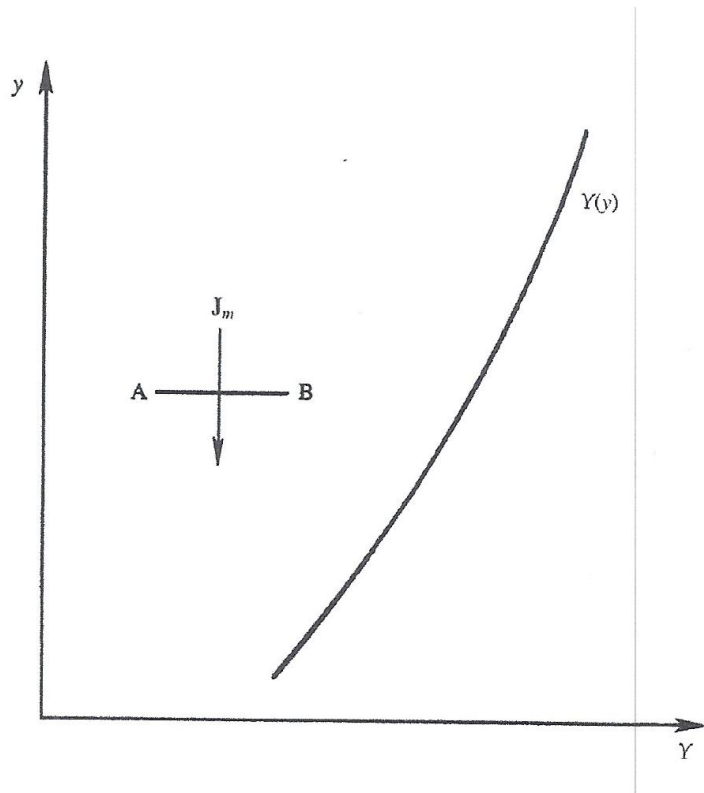

Gradient diffusion hypothesis: transport is down mean scalar gradient, i.e., direction $-\nabla\phi$ where $\phi = T$ or C .

Momentum Flux:

Newtonian Fluid: $\tau = \mu \frac{du}{dy} \left[\frac{N}{m^2} \right]$ 1D flow

(Rate of momentum flux/shear stress is proportional to the velocity gradient per unit area, which tends to smooth out the velocity profile).

$$\mu \left[\frac{Ns}{m^2} = \frac{kg}{ms} \right]$$

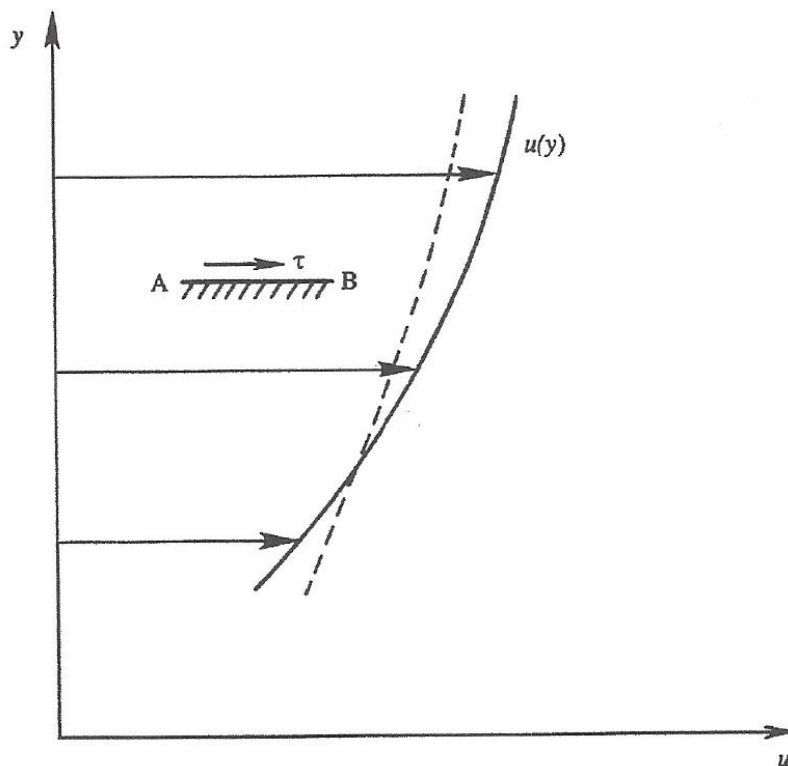

FIGURE 1.3 Shear stress τ on surface AB. The diffusive action of fluid viscosity tends to decrease velocity gradients, so that the continuous line tends toward the dashed line.

For 3D flow, the shear/rate of strain relationship is more complex, as will be shown later in the derivation of the momentum equation.

$$\sigma_{ij} = -p\delta_{ij} + \mu \left(\frac{\partial u_i}{\partial x_j} + \frac{\partial u_j}{\partial x_i} \right) + \delta_{ij}\lambda \nabla \cdot \underline{V}$$

Where $u_i = (u, v, w)$, $x_i = (x, y, z)$

$\lambda = 2^{\text{nd}}$ coefficient of viscosity = $\frac{2}{3}\mu$ (Stokes hypothesis)

For heat and mass, transported quantities are scalars and fluxes are vectors; whereas for momentum, transported quantity is a vector and flux is a tensor. Also, all three laws are phenomenological (i.e., based on empirical evidence: experience and experiments).

Non-Newtonian fluids follow nonlinear shear/rate of strain relationships:

$\tau \propto \epsilon_{ij}^n$	$n < 1$	pseudoplastic
	$n = 1$	Newtonian
	$n > 1$	dilatant

μ (and k) are also thermodynamic properties:

$$\mu = \mu(\text{gas or liquid, } T, p) \quad \text{Fig. A.1 Textbook}$$

For both gases and liquids, μ increases with p , but $\Delta \mu$ is small and usually neglected. For gases μ increases with T , whereas for liquids μ decreases with T . For gases, momentum transport and μ are roughly proportional to \sqrt{T} similarly as per random thermal speed. For liquids, shear stress is due to intermolecular cohesive forces more than thermal molecular motions, which decrease with T .

μ molecular theory ideal gas = $\frac{1}{3} \rho \bar{v} l$ where \bar{v} = average molecular speed and l = mean free path.

Kinematic viscosity:

$$\nu = \mu/\rho \left[\frac{m^2}{s} \right] \text{ arises in equations as}$$

diffusion coefficient Fig. A.2 Textbook

Viscous diffusion derives from molecular momentum diffusion: for non-dense gas due to molecular collisions; whereas for liquids due to local intermolecular cohesion arising from their close proximity.

Reynolds Number:

$$\text{Re} = \frac{UL\rho}{\mu} = \frac{UL}{\nu}$$

U = velocity scale,
L = length scale

The Reynolds number is an important nondimensional parameter (ratio inertia/viscous forces) which characterizes fluid flow: in particular, transition from laminar to turbulent flow!

Appendix A Physical Properties of Fluids

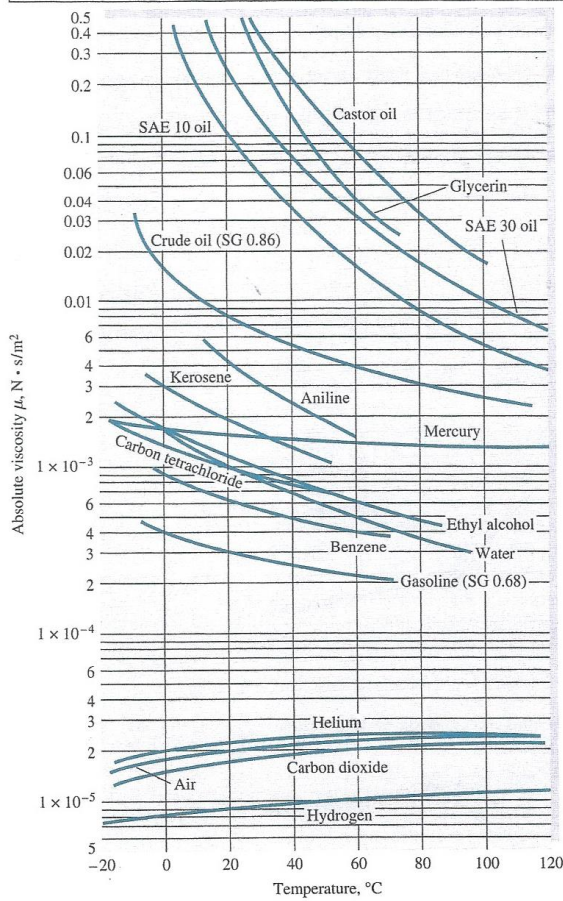

Fig. A.1 Absolute viscosity of common fluids at 1 atm.

808

$\mu_{\text{liquid}} \gg \mu_{\text{gas}}$

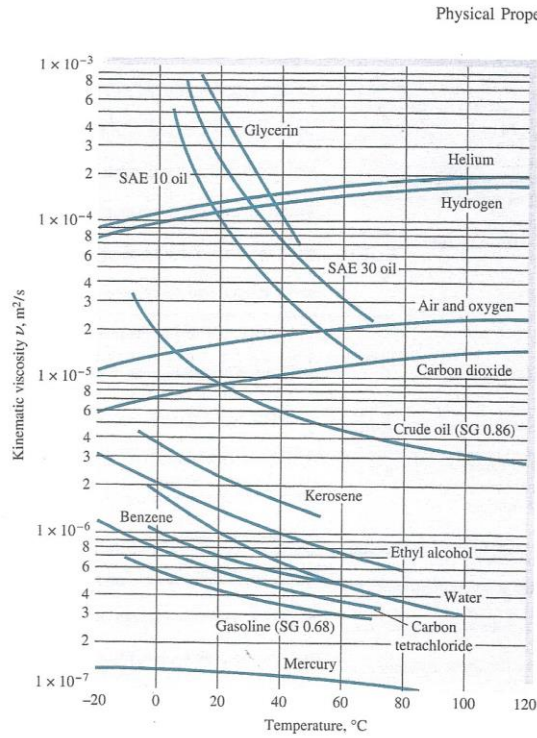

Fig. A.2 Kinematic viscosity of common fluids at 1 atm.

ν same trend μ vs. T , but ν liquid and ν gas similar order of magnitudes.

(3) Thermodynamic Properties

Classical Thermodynamics: the study of equilibrium states of matter, in which properties are assumed uniform in space and time.

Thermodynamic system = fixed mass separated from surroundings by boundary through which heat and work are exchanged (but not mass). Properties are state functions (i.e., depend on current state only and not path), whereas heat transfer and work are path functions.

A classical thermodynamic system is assumed static, whereas fluids are often in motion; however, if the relaxation time (time it takes material to adjust to a new state) is small compared to the time scale of fluid motion, an assumption is made that thermodynamic properties are point functions and that laws and state relations of static equilibrium thermodynamics are valid. In gases and liquids at normal pressure, relaxation time is very small; hence, only a few molecular collisions are needed for adjustment. Exceptions are rarefied gases, chemically reacting flows, sudden changes such as shock waves, etc.

For single-phase pure substances, only two properties are independent, and all others follow through the equations of state, which are determined experimentally or theoretically. Some mixtures, such as air, can also be considered a pure substance, whereas others such as salt water cannot and require additional numbers of independent properties, e.g., sea water requires three (salinity, T and p)

Pressure	p	[N/m ²]
Temperature	T	[K]
Density	ρ	[kg/m ³]
Internal Energy	û	[Nm/kg] = [J/kg]
Enthalpy	h = û + p/ρ	[Nm/kg] = [J/kg]
Entropy	s	[J/kg K]

$$\rho = \rho(p,T) \quad \hat{u} = \hat{u}(p,T) \quad h = h(p,T) \quad s = s(p,T)$$

Specific weight $\gamma = \rho g$ [N/m³]

$\rho_{\text{air}} = 1.205 \text{ kg/m}^3$	$\gamma_{\text{air}} = 11.8 \text{ N/m}^3$
$\rho_{\text{water}} = 1000 \text{ kg/m}^3$	$\gamma_{\text{water}} = 9790 \text{ N/m}^3$
$\rho_{\text{mercury}} = 13580 \text{ kg/m}^3$	$\gamma_{\text{mercury}} = 132,948 \text{ N/m}^3$

$$SG_{\text{gas}} = \frac{\rho_{\text{gas}}}{\rho_{\text{air}(20^\circ\text{C})}} = \frac{\rho_{\text{gas}}}{1.205 \text{ kg/m}^3} \quad SG_{\text{air}} = 1; SG_{\text{He}} = 0.138$$

$$SG_{\text{liquid}} = \frac{\rho_{\text{liquid}}}{\rho_{\text{water}(4^\circ\text{C})}} = \frac{\rho_{\text{liquid}}}{1000 \text{ kg/m}^3} \quad SG_{\text{water}} = 1; SG_{\text{Hg}} = 13.6$$

Total stored energy per unit mass (e):

$$e = \hat{u} + 1/2V^2 + gz$$

\hat{u} = energy due to molecular activity and bonding forces
(internal energy)

$1/2V^2$ = work required to change speed of mass from
0 to V per unit mass (kinetic energy)

gz = work required to move mass from 0 to
 $\underline{r} = x\hat{i} + y\hat{j} + z\hat{k}$ against $\underline{g} = -g\hat{k}$ per unit mass
($-m\underline{g} \cdot \underline{r}/m$) (potential energy)

(4) *Miscellaneous Properties*

Surface Tension:

Two non-mixing/immiscible liquids or liquids and gases form an interface across which there is a discontinuity in density. The interface behaves like a stretched membrane under tension. The tension originates due to strong intermolecular cohesive forces in the liquid that are unbalanced at the interface due to loss of neighbors, i.e., liquid molecules near the interface pull the molecules on the interface inward, resulting in the contraction of the interface.

σ = coefficient of surface tension N/m.

Surface tension is a line force = $F_\sigma = \sigma L$ where L = length of the cut through the interface

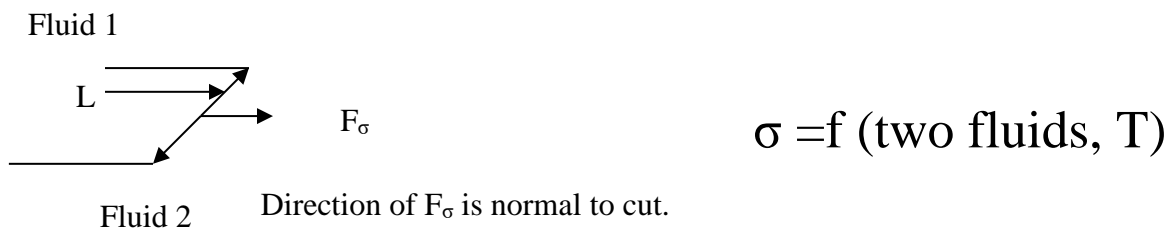

F_σ = force on an imaginary line drawn in any direction on the interface; line of action is on the surface and at right angles to the line.

$$\text{Weber number} = \frac{\rho V^2 L}{\sigma} = \frac{\text{inertia force}}{\text{surface tension force}} \frac{\rho V^2 / L}{\sigma / L^2} \quad \text{We}$$

Important parameter at gas-liquid or liquid-liquid interfaces and when these surfaces are in contact with a boundary.

Effects of surface tension:

- (1) Pressure jumps across curved interfaces (γ_f not considered, i.e., force balance at interface only)

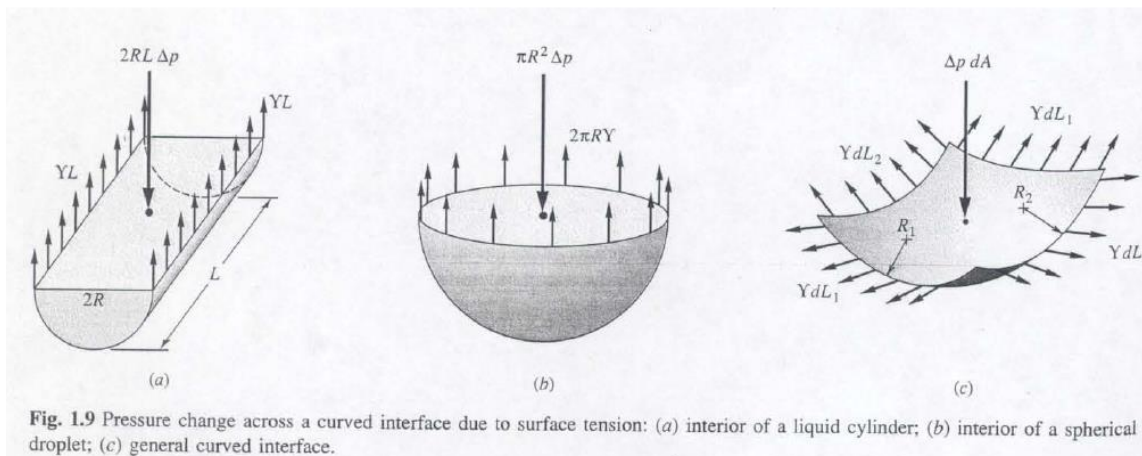

(a) Cylindrical interface

Force Balance:

$$2\sigma L = (p_i - p_o) 2RL$$

$$\Delta p = \sigma / R$$

$p_i > p_o$, i.e., pressure is larger on concave vs. convex side of interface

(b) Spherical interface (droplet)

$$\pi 2R\sigma = \pi R^2 \Delta p \quad \rightarrow \quad \Delta p = 2\sigma/R$$

(c) Bubble

$$\pi 2R\sigma + \pi 2R\sigma = \pi R^2 \Delta p \quad \rightarrow \quad \Delta p = 4\sigma/R$$

(d) General interface

$$\Delta p = \sigma(R_1^{-1} + R_2^{-1})$$

$R_{1,2}$ = principal radii of curvature

(2) Contact Angle

When the surface of a solid intersects the interface the contact angle can either be wetting ($\theta < 90^\circ$) or non-wetting ($\theta > 90^\circ$). θ depends on both the two fluids and the solid surface properties. For clean glass intersecting an air-water interface $\theta=0$ (wetting) and an air-mercury interface $\theta=135$ (nonwetting).

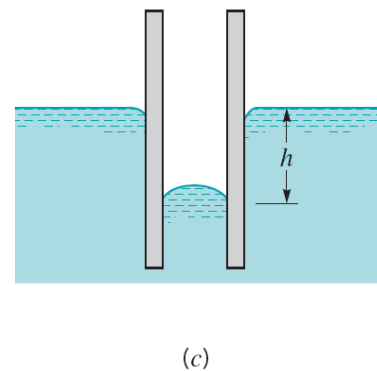
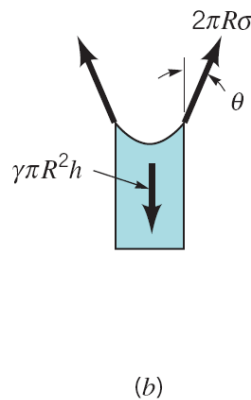
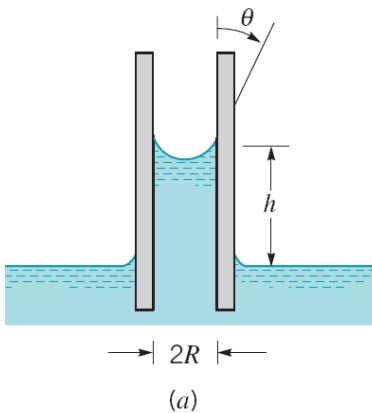

$\theta < 90^\circ$
 wetting

$\theta > 90^\circ$
 non-wetting

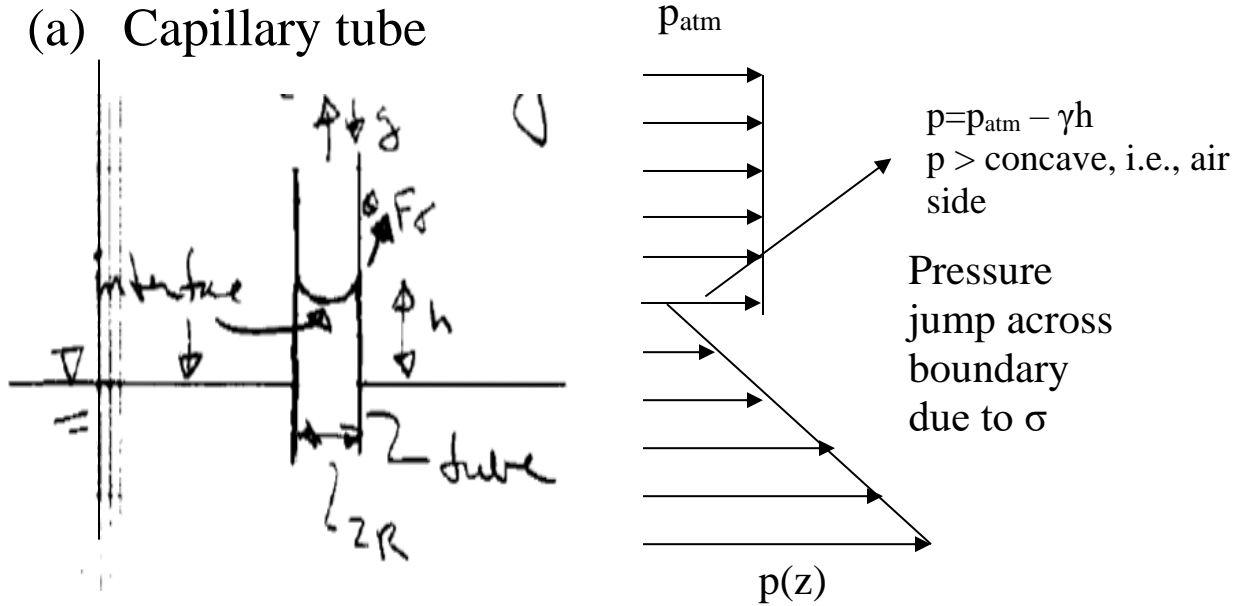

Surface Tension Force = Weight of fluid

$$\pi 2R\sigma \cos \theta = \rho g h \pi R^2$$

$$h = \frac{2\sigma \cos \theta}{\gamma R} \quad h \propto R^{-1} \text{ (i.e., larger } h \text{ for smaller } R)$$

Non-wetting
 drives liquid
 down tube

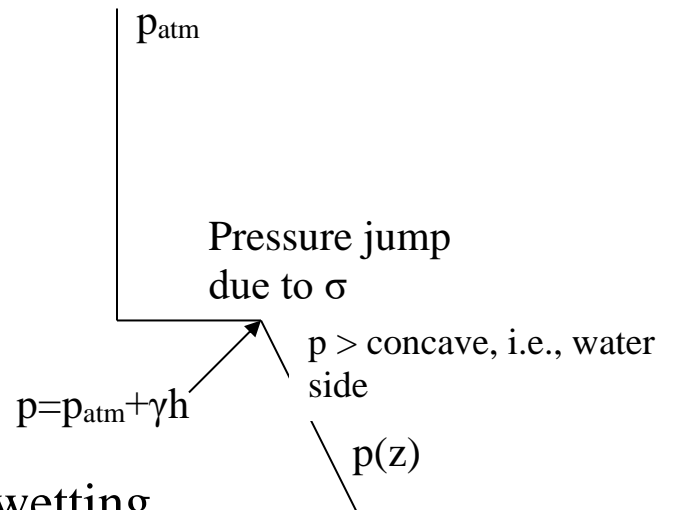
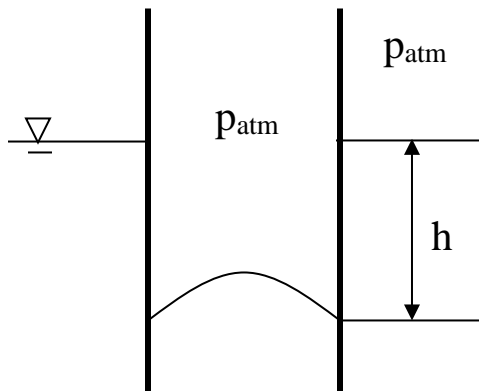

$h > 0 = \text{wetting, } h < 0 = \text{non-wetting}$

(b) Parallel plates

For two parallel plates $2R$ apart with span b :

Surface Tension Force = Weight of fluid = $\gamma \nabla$

$$2b\sigma\cos\theta = \rho gh2Rb \Rightarrow h = \frac{\sigma\cos\theta}{\gamma R}$$

(c) Pressure jump (hydrostatic pressure variation:
Chapter 2)

$$\frac{dp}{dz} = -\gamma \Rightarrow p = -\gamma z + c = -\gamma z + p_{atm} \Rightarrow \Delta p_{at\ z=h} = p_{z=h} - p_{atm}$$

$$= -\gamma h \quad \text{wetting}$$

$$= \gamma h \quad \text{non-wetting}$$

For general interface:

$h > 0$ (wetting):

$$\Delta p = \sigma(R_1^{-1} + R_2^{-1}) = -\gamma h < 0 \Rightarrow p_{water} < p_{air} \Rightarrow \text{concave shape}$$

$h < 0$ (non-wetting):

$$\Delta p = \sigma(R_1^{-1} + R_2^{-1}) = \gamma h > 0 \Rightarrow p_{water} > p_{air} \Rightarrow \text{convex shape}$$

(3) Transformation liquid jet into droplets

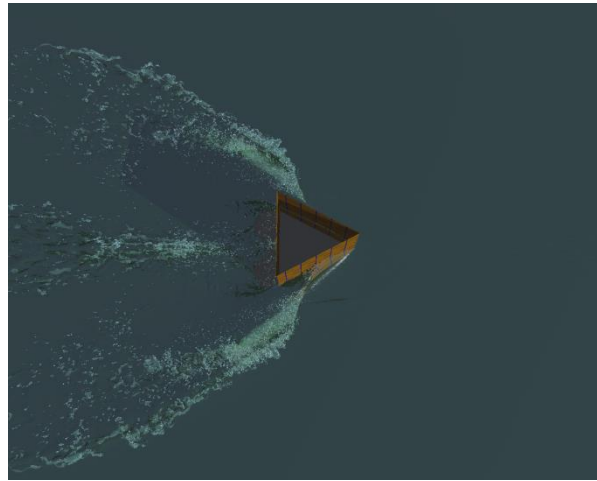

Figure 1. Wave breaking around a wedge-shaped bow.

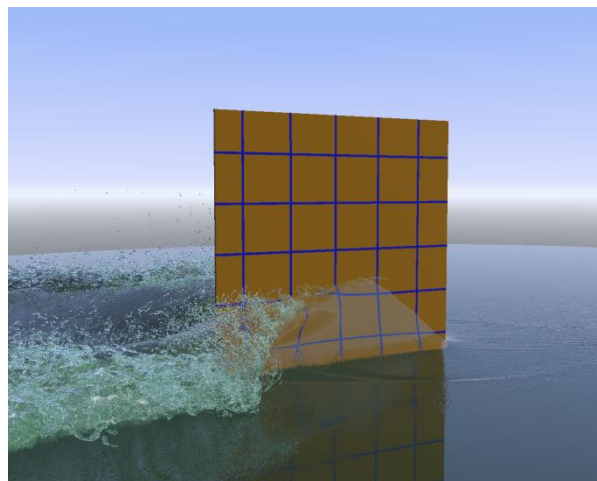

Figure 2. Wave profile of the wedge flow.

[Movie Wedge Wave](#)

(4) Binding of wetted granular material such as sand

(5) Capillary waves

Like stretched membrane (string) waves, surface tension acts as restoring force resulting in interfacial waves called capillary waves.

Cavitation:

When the pressure in a liquid falls below the vapor pressure, it will evaporate (i.e., become a gas). If due to temperature changes alone, the process is called boiling, whereas if due to liquid velocity, the process is called cavitation.

$$Ca = \frac{P_a - P_v}{1/2\rho U^2}$$

Ca = Cavitation #

p_v = vapor pressure

p_a = ambient pressure

U = characteristic velocity

If the local pressure coefficient C_p ($C_p = \frac{p - p_a}{1/2\rho U^2}$) falls below the cavitation number Ca , the liquid will cavitate.

$$Ca = f(\text{liquid/properties, } T)$$

Effects of cavitation:

- (1) erosion
- (2) vibration
- (3) noise

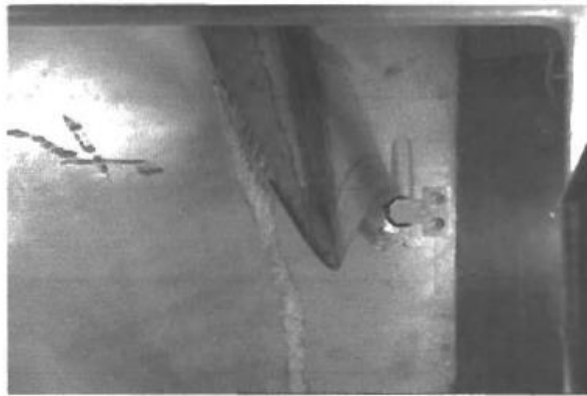

(a) Experiment

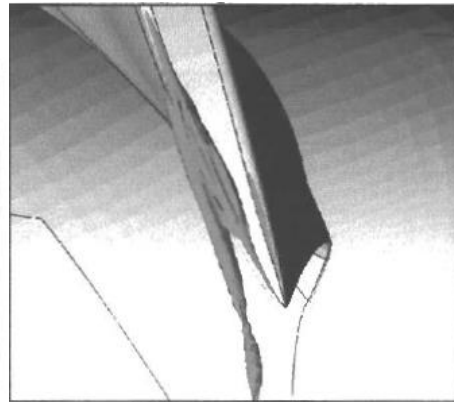

(b) Computation
Cavitation comparison with experiment

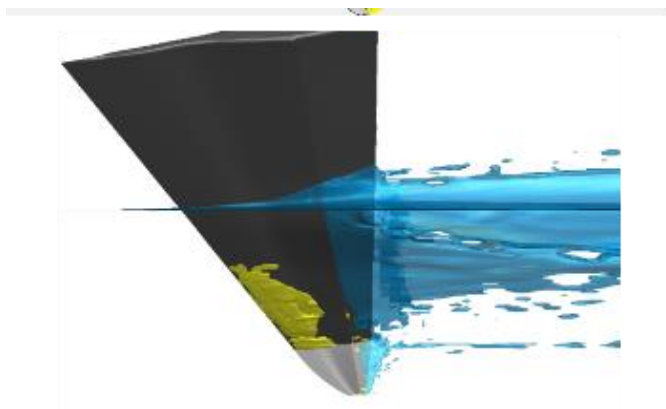

[Movie: SPSC Foil](#)

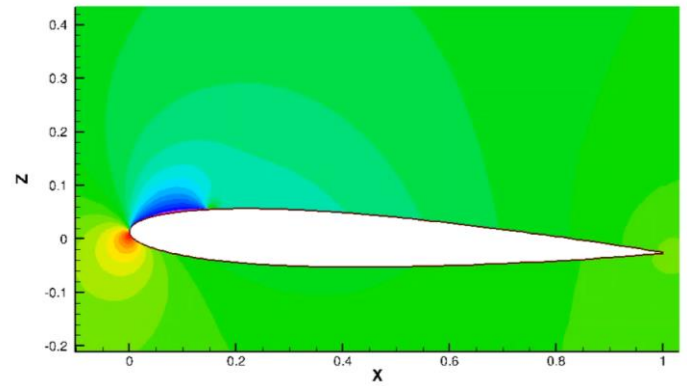

[Movie: Pitching Foil](#)

Flow Classification:

- (1) Spatial dimensions: 1D, 2D, 3D
- (2) Steady or unsteady: $\frac{\partial}{\partial t} = 0$ or $\frac{\partial}{\partial t} \neq 0$
- (3) Compressible ($\rho \neq \text{constant}$) or incompressible ($\rho = \text{constant}$)
- (4) Inviscid or Viscous: $\mu = 0$ or $\mu \neq 0$.
- (5) Rotational or Irrotational: $\underline{\omega} \neq 0$ or $\underline{\omega} = 0$.
- (6) Inviscid/Irrotational: potential flow
- (7) Viscous, laminar, or turbulent: Re_{trans}
- (8) Viscous, low Re: Stokes flow
- (9) Viscous, slender body, high Re slender body
external flow: boundary layer
- (10) Etc.

Depending on flow classification, different approximations can be made to exact governing differential equations resulting in different forms of approximate equations and analysis techniques.

Flow Analysis Techniques:

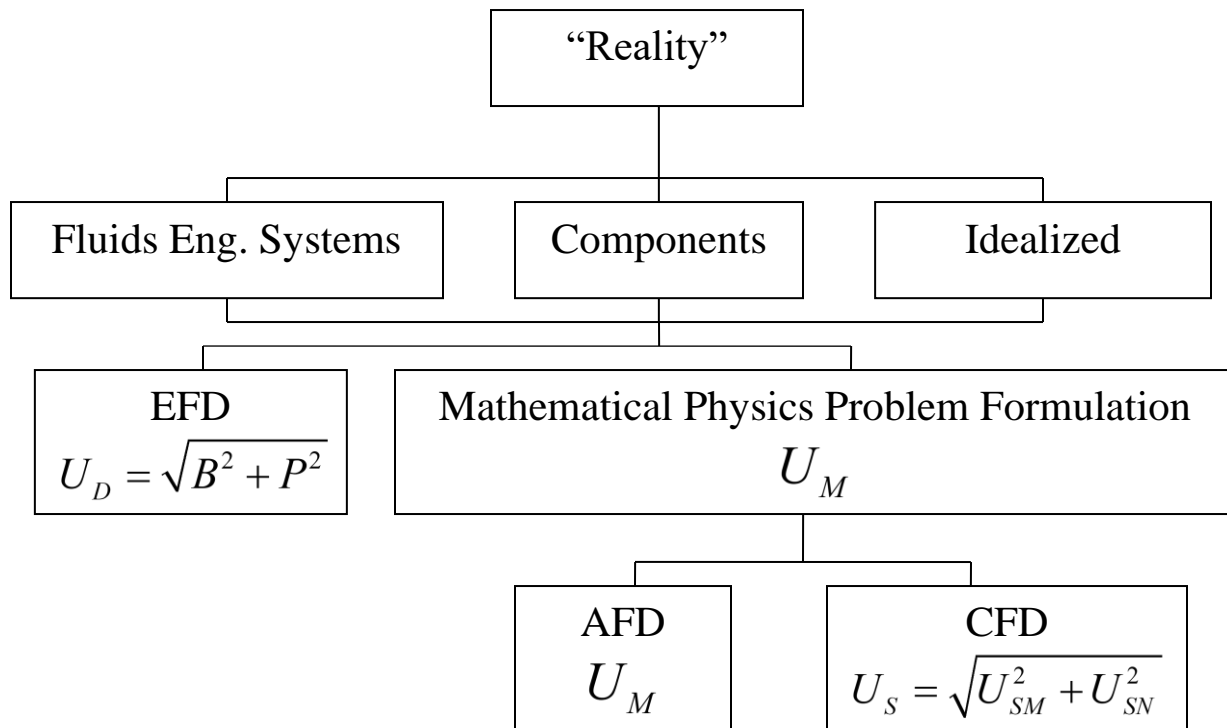

In addition, AFD and CFD (high fidelity) current research involves multi-fidelity and ML&AI approaches.